

MANUAL

CBX500
CONNECTION BOX





With regard to the supply of products, the current issue of the following document is applicable: The General Terms of Delivery for Products and Services of the Electrical Industry, published by the Central Association of the Electrical Industry (Zentralverband Elektrotechnik und Elektroindustrie (ZVEI) e.V.) in its most recent version as well as the supplementary clause: "Expanded reservation of proprietorship"

TABLE OF CONTENTS

- 1 OPERATING ELEMENTS.....2
- 2 SERVICES AND SUPPORT4
- 3 DESCRIPTION4
- 4 SAFETY PRECAUTIONS4
- 5 SUPPORTED READING DEVICE MODELS4
- 6 OPENING THE CBX5005
- 7 MECHANICAL INSTALLATION5
- 8 ELECTRICAL CONNECTIONS AND SETUP6
- 9 POWER SUPPLY.....6
- 10 SYSTEM WIRING7
- 11 PINOUT.....8
- 12 POWER SOURCE JUMPER SETTINGS9
- 13 SHIELD TO PROTECTION EARTH JUMPER SETTINGS9
- 14 CHASSIS GROUNDING JUMPER SETTINGS9
- 15 9-PIN READING DEVICE AUXILIARY SERIAL INTERFACE.....10
- 16 NETWORK BUS TERMINATION.....10
- 17 INDICATOR LEADS11
- 18 TECHNICAL FEATURES12
- 19 COMPLIANCE13
 - Power Supply13
 - CE Compliance13
 - FCC Compliance13
- 20 DECLARARION OF CONFORMITY13

1 OPERATING ELEMENTS

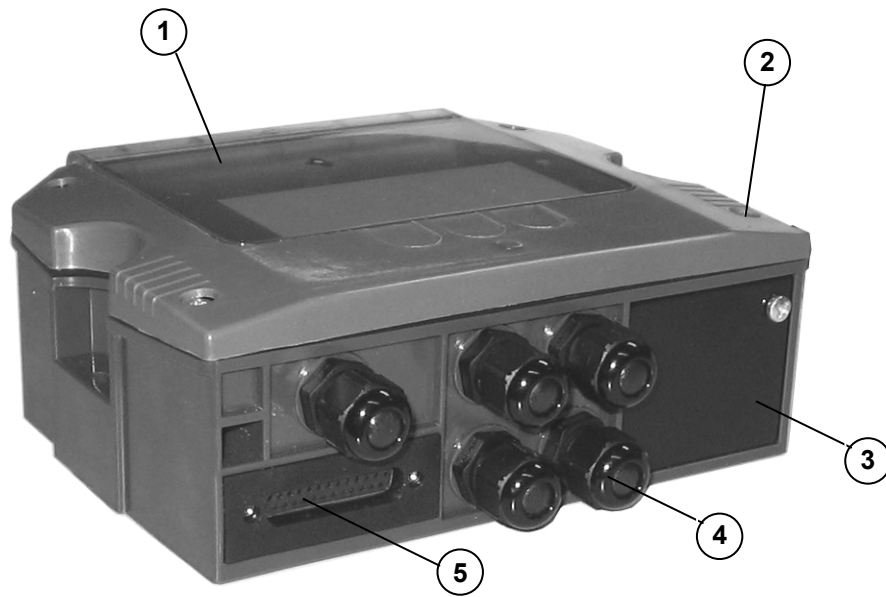

Figure A

- ① Indicator LEDs
- ② Cover Screws (4)
- ③ Fieldbus Interface Panel
- ④ Compression Connectors (5)
- ⑤ 25-pin Device Connector

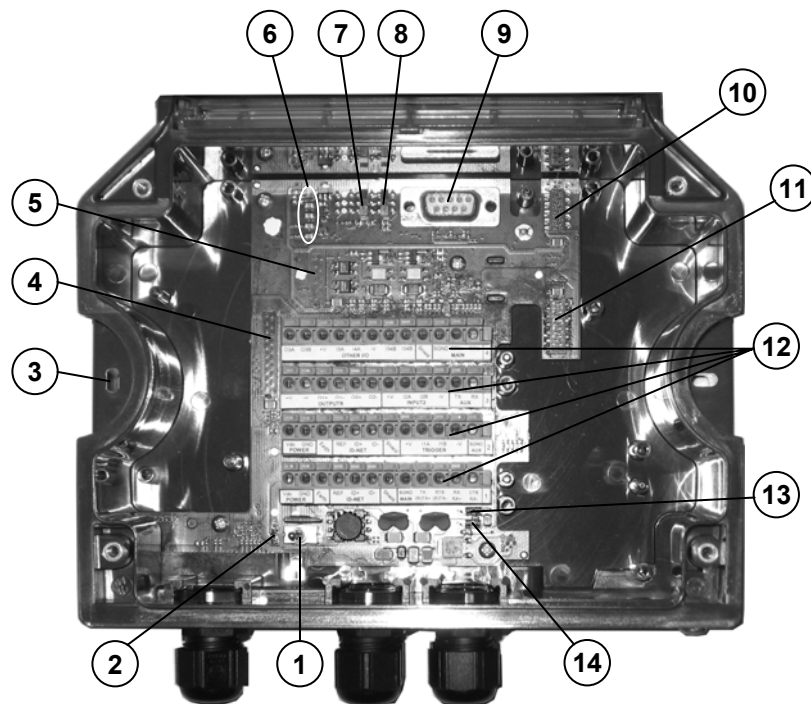

Figure B

- ① Power switch (ON/OFF)
- ② Device Chassis Grounding Selector
- ③ Mounting Holes (2)
- ④ I/O Extension Module Connector
- ⑤ Backup Module Connector
- ⑥ Indicator LEDs
- ⑦ RS485 Termination Resistance Switch
- ⑧ ID-NET™ Termination Resistance Switch
- ⑨ Auxiliary Port Connector
- ⑩ IP65 Fieldbus Module Connector
- ⑪ Standard Fieldbus Module Connector
- ⑫ Spring Clamp Terminal Blocks
- ⑬ Shield to Protection Earth Selector
- ⑭ Power Source Selector

2 SERVICES AND SUPPORT

Pepperl+Fuchs provides several services as well as technical support through its website. Log on to www.pepperl-fuchs.com for further information or contact your local seller.

3 DESCRIPTION

The CBX500 is a connection box which can be used as an accessory to facilitate system connections for installation and device replacement of several Pepperl+Fuchs family reading devices.

System cabling is made through spring clamp terminal blocks inside the CBX500 while the reading device is connected to the CBX500 through a 25-pin connector on the housing.

A 9-pin connector placed inside the CBX500 facilitates connection between an external PC and the auxiliary serial interface of the reading device for configuration or data monitoring.

CBX500 can also house several accessories which make the system highly flexible. These include:

- Backup Module - to backup and restore system configuration parameters making system maintenance extremely quick and easy.
- Display Module – to show reading device menu and diagnostic messages at the CBX500.
- Several Host Interface Modules - to interface the scanner with the most popular Fieldbus network types: Ethernet, Profibus; DeviceNet, etc., including IP65 protection versions.

4 SAFETY PRECAUTIONS

ATTENTION: READ THIS INFORMATION BEFORE INSTALLING THE PRODUCT

POWER SUPPLY

This product is intended to be installed by Qualified Personnel only.

This device is intended to be supplied by a UL Listed NEC Class 2 power source, rated 10-30V, minimum 0.50A.

 CAUTION	<p><i>The overall value of power consumption of the system (CBX500 + reading device) is given by adding the reading device power consumption to that of the CBX500. Refer to the manual of the connected reading device for details about minimum/maximum supply voltage and power consumption.</i></p>
---	---

5 SUPPORTED READING DEVICE MODELS

The CBX500 can be directly connected to the following readers through the 25-pin connector illustrated in Figure A.

Linear Scanners			
VB14N-300-*	VB14N-600-*	VB33-*	VB34-*

6 OPENING THE CBX500

To install the CBX500 or during normal maintenance, it is necessary to open it by unscrewing the four cover screws:



The CBX500 must be disconnected from the power supply during this operation.

CAUTION

7 MECHANICAL INSTALLATION

CBX500 can be mounted to various wooden or plastic surfaces using the two self-threading screws (3.9 x 45 mm) and washers provided in the package.

Mounting to other surfaces such as concrete walls or metallic panels requires user-supplied parts (screws, screw anchors, nuts, etc). A mounting template is included in the package to facilitate hole drilling alignment.

The diagram below gives the overall dimensions of the CBX500 and shows the two mounting through-holes.

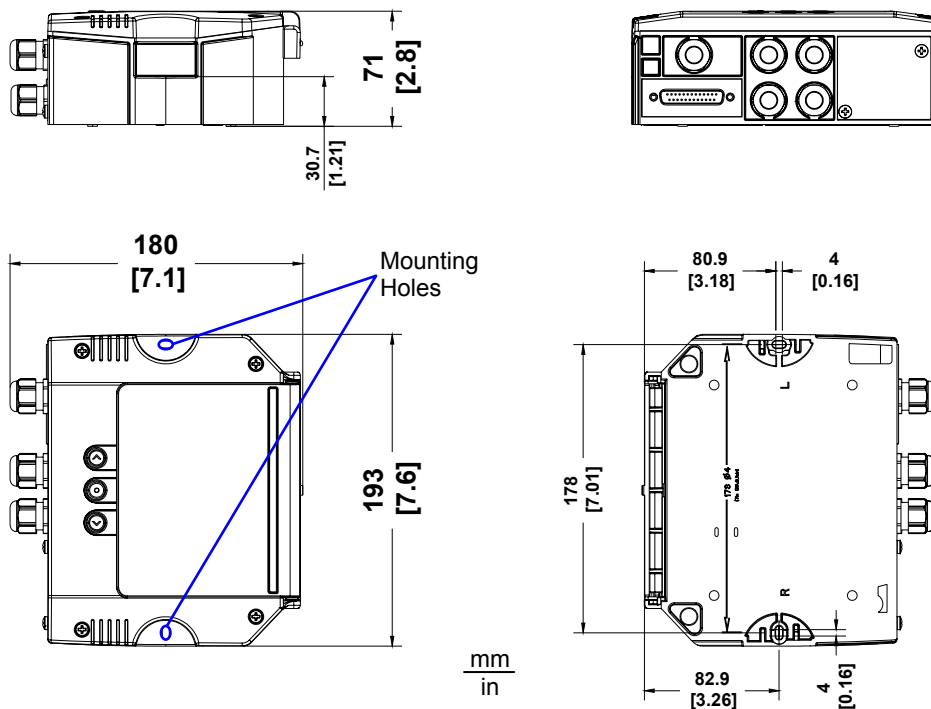

Figure 1 - Overall Dimensions

8 ELECTRICAL CONNECTIONS AND SETUP

The following figure shows the typical layout.

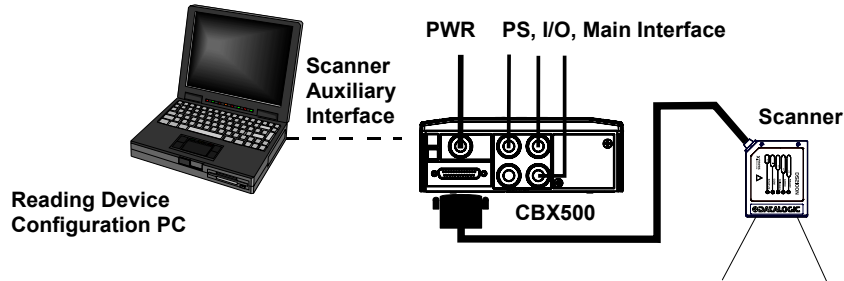

Figure 2 – System Layout

The dotted line in the figure refers to an optional (temporary) hardware configuration in which a portable PC can be quickly connected to the CBX500 (and consequently to the reading device auxiliary interface) through the internal 9-pin connector. This allows monitoring of the data transmitted by the reading device or configuration through the utility program (see the reading device Installation Manual for more details). The reading device auxiliary interface signals are also available on the internal spring clamp connectors.

After making system cabling and switch settings, connect the reading device to the 25-pin connector on the CBX500 housing.

Switch ON the CBX500 power switch (see Figure 3). The Power LED turns on (blue) when the power connection has the correct polarity. The Power LED turns on (red) in case of wrong polarity.

After system functioning has been verified, close the CBX500 using the four cover screws.

9 POWER SUPPLY

Power is supplied to the CBX500 through the Vdc and GND pins provided on the spring clamp connector.

The power switch (see Figure 3) switches the power supply ON or OFF for both the CBX500 and the connected reading device.

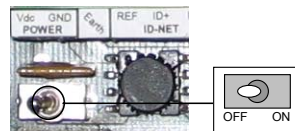

Figure 3 - Power Switch ON/OFF Positions

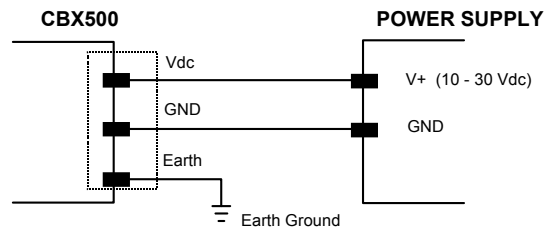



Figure 4 - Power Supply Connections



NOTE

Vdc is electrically connected to +V, just as GND is electrically connected to -V. This is useful for supplying external trigger, inputs and outputs from the CBX500 power source, however +V and -V signals should not be used as power supply inputs to the CBX500.

The power supply must be between 10 and 30 Vdc only.

10 SYSTEM WIRING

The connection and wiring procedure for CBX500 is described as follows:

- 1) Open the CBX500 by unscrewing the four cover screws.
- 2) Verify that the CBX500 power switch is off (see Figure 3).
- 3) Unscrew the compression connectors and pass all the system cables through them into the CBX500 housing.
- 4) To connect the power and input/output signals:
 - Prepare the individual wires of the system cables by stripping the insulation back approximately 1 cm.
 - Using a device such as a screwdriver, push down on the lever directly next to the clamp (see Figure 5).
 - Insert the wire into the clamp and release the lever.

The wire will now be held in the spring clamp.

- 5) Tighten the compression connector nuts so that the internal glands seal around the cables.

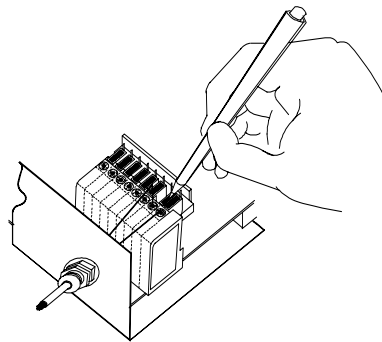

Figure 5 - System Cable Connections

Flexible stranded wire should be used and must meet the following specifications.

All positions: 24 - 16 AWG 0.2 - 1.5 mm²

The CBX500 spring clamp connector pinouts are indicated in the Pinout table.

Refer to the reading device Installation Manual for signal details.

11 PINOUT

Pinouts				
Group	Name	Function		
Input Power	Vdc	Power Supply Input Voltage +		
	GND	Power Supply Input Voltage -		
	Earth	Protection Earth Ground		
External Trigger Input	+V	Power Source – External Trigger		
	I1A	External Trigger A (polarity insensitive)		
	I1B	External Trigger B (polarity insensitive)		
	-V	Power Reference – External Trigger		
Generic Input	+V	Power Source – Inputs		
	I2A	Input 2A (polarity insensitive)		
	I2B	Input 2B (polarity insensitive)		
	-V	Power Reference – Inputs		
Outputs	+V	Power Source – Outputs		
	-V	Power Reference – Outputs		
	O1+	Output 1+		
	O1-	Output 1-		
	O2+	Output 2+		
	O2-	Output 2-		
Auxiliary Interface	TX	Auxiliary Interface TX		
	RX	Auxiliary Interface RX		
	SGND	Auxiliary Interface Reference		
ID-NET™	REF	Network Reference		
	ID+	ID-NET™ network +		
	ID-	ID-NET™ network -		
Network	Shield	Network Cable Shield		
		RS232	RS485FD	RS485HD
Main Interface		TX	TX+	RTX+
		RTS	TX-	RTX-
		RX	*RX+	
		CTS	*RX-	
		SGND	SGND	SGND

The input power signals **Vdc**, **GND** and **Earth** as well as the network signals **REF**, **ID+**, **ID-** and **Shield** are repeated to facilitate system cabling. In this way the power and network busses can enter and exit the CBX500 from different spring clamps but be physically connected together.

* Do not leave floating, see Reading Device Reference Manual for connection details.

 NOTE	<i>To avoid electromagnetic interference:</i>		
	- Connect CBX500 Protection Earth (Earth) to a good earth ground.		
	- Connect the reading device chassis to earth ground through the jumper, (default setting, see Figure 8).		
	- Connect the Network Cable Shield (Shield) to Filtered Earth through the jumper (default setting, see Figure 7).		

12 POWER SOURCE JUMPER SETTINGS

For most applications input power is provided through the dedicated spring clamp connectors inside the CBX500. However CBX500 may accept power from the connected reading device through the 25-pin connector. This is useful, for example, to pass power to connected accessories such as Encoder and Presence Sensor from VB33 / VB34 scanners powered directly through the network. See the relative reading device Reference Manual for details. To power CBX500 from the reading device, the power source jumper must be placed in the "power from device" position as indicated in Figure 6.

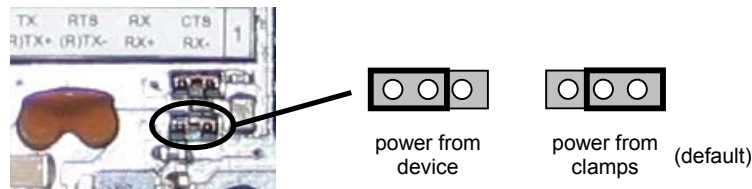

Figure 6—Power Source Jumper Settings

13 SHIELD TO PROTECTION EARTH JUMPER SETTINGS

The network shield (Shield) can be connected to Earth Ground (Earth) either directly or through a filter circuit. If the jumper is left open, the network cable shield (Shield) is floating.

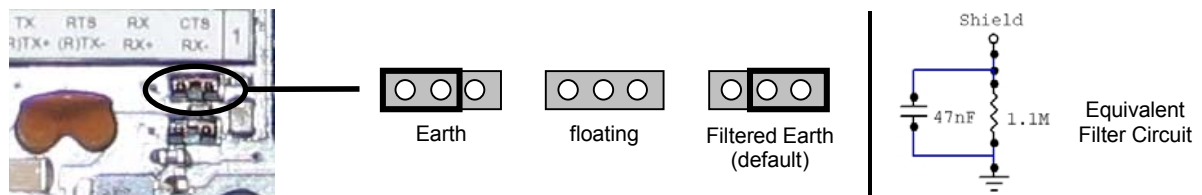

Figure 7—Shield to Protection Earth Jumper Settings

14 CHASSIS GROUNDING JUMPER SETTINGS

The reading device chassis grounding method can be selected by positioning a jumper (see Figure 8). In this way the reading device chassis can be connected to earth ground (only if pin Earth is connected to a good earth ground). For all reading devices except VB33 and VB34 series, the chassis can alternatively be connected to the power supply ground signal (GND) or it can be left floating but, in this case, the jumper must be removed. For VB33 and VB34 scanners the chassis is internally connected to GND.

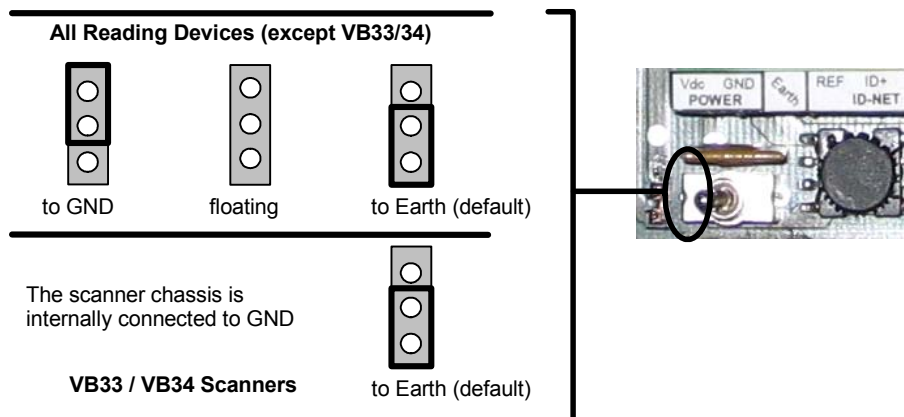

Figure 8 – Chassis Grounding

15 9-PIN READING DEVICE AUXILIARY SERIAL INTERFACE

The reading device auxiliary serial interface available on the internal CBX500 9-pin connector can be used either for configuration or for data monitoring.

Connections can be made to a PC or Laptop using a straight through cable or a USB-RS232 converter.

The details of the connector pins are indicated in the following table:

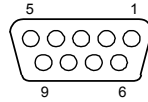

Figure 9 - 9-pin D-Sub Female Connector

9-pin Connector Pinout		
Pin	Name	Function
2	TX	Auxiliary RS232
3	RX	Auxiliary RS232
5	SGND	Auxiliary Reference Ground
1, 4, 6, 7, 8, 9		N.C.

16 NETWORK BUS TERMINATION

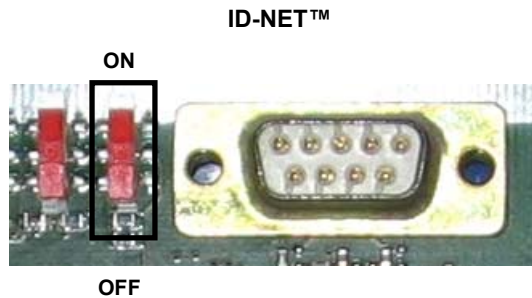

Figure 10 – ID-NET™ Termination Resistance Switch

The ID-NET™ termination resistance switch enables or disables the insertion of the bus termination resistor for ID-NET™ network applications.

 CAUTION	<p><i>In ID-NET™ network applications the termination resistor must be enabled ONLY on the first and last devices of the chain. On all the other devices this resistor MUST NOT be enabled (OFF).</i></p>
--------------------	---



Figure 11 – RS485 HD Termination Resistance Switch

The RS485 HD termination resistance switch enables or disables the insertion of the bus termination resistor for RS485 Half Duplex Multidrop applications.



CAUTION

In Multiplexer applications the termination resistor must be enabled ONLY on the last device of the chain, the farthest away from the Multiplexer (assuming the Multiplexer is the first device of the chain). On all the other devices this resistor MUST NOT be enabled (OFF).

17 INDICATOR LEDES

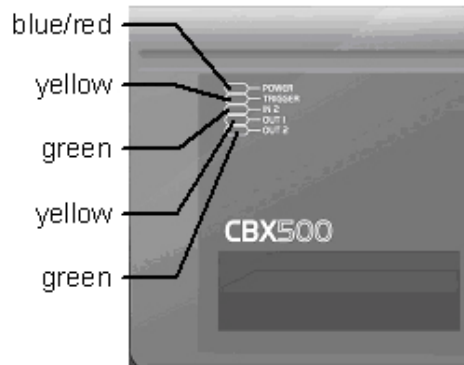



Figure 12 – Indicator LEDs

There are five Indicator LEDs which signal power and I/O activity and are visible from the CBX500 outside cover.

The Power LED is blue when power is correctly applied to the CBX500 and the power switch is turned on.

This LED is red if power polarity is incorrect. In this case the connected reading device and optional Backup Module are protected.



CAUTION

If external I/O devices are powered through CBX500 (connected to +V/-V), they are not protected from polarity inversion.

The remaining four LEDs signal activity on the relative I/O lines. Their meaning depends on the software configuration of the connected reading device.

18 TECHNICAL FEATURES

ELECTRICAL FEATURES	
Supply Voltage	10 to 30 Vdc*
Power Consumption	0.5 W + reading device power consumption (see related manual)
Max Current Consumption	2.5 A
USER INTERFACE	
LED Indicators	Power On/Polarity Error (blue/red) Trigger (yellow) IN2 (green) OUT1 (yellow) OUT2 (green)
PHYSICAL FEATURES	
Mechanical Dimensions	193 x 180 x 71 mm (7.6 x 7.1 x 2.8 in.)
Weight	about 780 g. (27.5 oz.)
ENVIRONMENTAL FEATURES	
Operating Temperature	-10° to 50 °C (+14° to 122 °F)
Storage Temperature	-20° to 70 °C (-4° to 158 °F)
Humidity max.	90% non condensing
Vibration Resistance EN 60068-2-6 2 hours on each axis	14 mm @ 2 to 10 Hz 1.5 mm @ 13 to 55 Hz 2 g @ 70 to 200 Hz
Shock Resistance EN 60068-2-27	30 g; 11 ms; 3 shocks on each axis
Protection Class	IP65 (when compression connectors and reading device are correctly connected)

The features given are typical at a 25 °C ambient temperature (if not otherwise indicated).

* for further details about minimum/maximum supply voltage refer to the manual of the connected reading device, since the minimum supply voltage required may be >10.

19 COMPLIANCE

POWER SUPPLY

This product is intended to be installed by Qualified Personnel only.

This accessory device is intended to be supplied by a UL Listed or CSA Certified Power Unit with «Class 2» or LPS power source, which supplies power directly to the scanner via the 25-pin connector.

CE COMPLIANCE

Warning: This is a Class A product. In a domestic environment this product may cause radio interference in which case the user may be required to take adequate measures.

FCC COMPLIANCE

Modifications or changes to this equipment without the expressed written approval of Pepperl+Fuchs could void the authority to use the equipment.

This device complies with PART 15 of the FCC Rules. Operation is subject to the following two conditions: (1) This device may not cause harmful interference, and (2) this device must accept any interference received, including interference which may cause undesired operation.

This equipment has been tested and found to comply with the limits for a Class A digital device, pursuant to part 15 of the FCC Rules. These limits are designed to provide reasonable protection against harmful interference when the equipment is operated in a commercial environment. This equipment generates, uses, and can radiate radio frequency energy and, if not installed and used in accordance with the instruction manual, may cause harmful interference to radio communications. Operation of this equipment in a residential area is likely to cause harmful interference in which case the user will be required to correct the interference at his own expense.

20 DECLARATION OF CONFORMITY

This product has been developed and manufactured in accordance with applicable European standards and directives.

A Declaration of Conformity can be requested from the manufacturer.

The manufacturer of this product has a certified quality management system in accordance with ISO 9001.

FACTORY AUTOMATION – SENSING YOUR NEEDS



Worldwide Headquarters

Pepperl+Fuchs GmbH
68307 Mannheim · Germany
Tel. +49 621 776-0
E-mail: info@de.pepperl-fuchs.com

USA Headquarters

Pepperl+Fuchs Inc.
Twinsburg, Ohio 44087 · USA
Tel. +1 330 4253555
E-mail: sales@us.pepperl-fuchs.com

Asia Pacific Headquarters

Pepperl+Fuchs Pte Ltd.
Company Registration No. 199003130E
Singapore 139942
Tel. +65 67799091
E-mail: sales@sg.pepperl-fuchs.com

www.pepperl-fuchs.com

 **PEPPERL+FUCHS**
SENSING YOUR NEEDS