

FACTORY AUTOMATION

ADDING SAFETY TO YOUR BUS AS-INTERFACE PRODUCTS



AS-INTERFACE SAFETY SOLUTIONS—MAKING SAFETY SIMPLE

PEPPERL+FUCHS MAKES IT EASY TO WIRE YOUR SAFETY CIRCUITS!



AS-Interface Safety systems enable networking of safety devices (safety door switches, emergency stop pushbuttons, safety light curtains, etc.) using standard AS-Interface networks. Users can quickly implement a safety system that satisfies the rules and regulations needed for Category 4/SIL 3 Safety and soon the new EN ISO 13849 standard. The simplicity of AS-Interface is retained and is a major reason for users to implement AS-Interface safety technology.



SAFETYMONITOR

The SafetyMonitor is the safe controller on AS-Interface. Its primary functions are to evaluate the safe data from the safe input models, perform logic operations, and if needed, activate internal or remote release circuits. Constructed to meet safety requirements, the SafetyMonitor easily connects to the AS-Interface network. Pepperl+Fuchs offers safety monitors with integrated PROFIBUS and Ethernet/IP gateways as well.

- Monitors two networks simultaneously
- Four integrated safe contacts (two relays/two electronic)
- Up to 16 independent, remote release circuits
- Up to 16 independent coupling variables
- 256 configuration block memory
- Graphical display
- Many other unique features:
 - Noise detector
 - Duplicate address detection
 - Memory card
 - Etc.
- [A low-end SafetyMonitor for small systems is also available](#)



SAFE OUTPUT MODULE

The safe output module has the same safety output rating as a SafetyMonitor and is controlled by the SafetyMonitor. All of the programming and logic still resides on the SafetyMonitor itself. Safe outputs are often used to safely control motors. Multiple remote safe output modules can be associated with the same safe data channel if required.

- Functionality of inputs user selectable
 - EDM input + three standard inputs
 - EDM input + diagnostics data
- One ALARM output (LED) on module
- One safe output (two sets of safe contacts)



SAFETY DOOR INTERLOCK SWITCHES

Safety switches are tasked with preventing machine operation in the event of a potential hazard. Every safety switch has two internal contacts that are safely opened when the key is removed—with or without solenoid locking function.

- Power-to-lock or Power-to-unlock
- Powered from AS-Interface or powered from AUX
- High-visibility LEDs on some models
- Interchangeable keys
- Common mounting foot print allows simple replacement of conventional switches



SAFE MAGNETIC DOOR SWITCHES

Noncontact magnetic switches are designed for use on moveable machine guarding components. Their size is identical to comparable dry contact conventional magnetic door switches.

These low-cost switches use coded magnets, meaning that a simple magnet cannot be used to bypass the safety operation. Because of their rugged, noncontact design, these switches withstand typical mechanical abuse and vibration.

- Common form factors allow drop-in replacement
- M12 connection directly to AS-Interface

RFID-BASED SAFE DOOR SWITCHES

RFID safety door switches are superior to simple magnetic switches because they use an RFID tag as their safe target. Due to the RFID technology, alignment issues are a thing of the past. This solution offers significant improvements over magnetic door switches in high vibration environments. RFID switches cannot be bypassed or overridden like other noncontact guard switching technologies making them the safest technology in the industry.

- Up to four doors can be protected with one controller
- Perfect switch point hysteresis for higher operational reliability



E-STOPS

Our emergency stops connect directly to the AS-Interface cable for easy mounting. This reduces the overall wiring/complexity of your machine. The four versions available are: illuminated panel mount, non-illuminated panel mount, illuminated field mount, and non-illuminated field mount.

- IP20 or IP65
- Pull and twist release



SAFE ENABLING SWITCH

Enabling switches are safety devices that allow a user to enter a potentially harmful area to do required maintenance without shutting the machine down. The three-position device (OFF-ON-OFF) must be continuously held in the center position to enable machine power. If the user senses an unsafe condition they can fully push or release the enabling switch, shutting down the machine. This device is particularly useful in robotics applications in conjunction with our 16-channel SafetyMonitor and the safe output modules.

- Ergonomic design
- The three-position device (OFF-ON-OFF) design



NETWORKS CAN BE ANY SIZE

A new feature of our line of high-powered AS-Interface SafetyMonitors is their ability to transmit data safety between multiple networks. This gives engineers the ability to design safe networks of just about any size. In the setup below, the e-stop on network 2 can deactivate the safe output module contacts on network 1; the light curtain on network 1 can be configured to deactivate safe outputs on network 2, and so on. The interconnecting network (called the coupling network shown as a hatched line) can still contain safe and standard devices, an e-stop in this case.

- Up 961 safe inputs can be interconnected on 31 coupled networks
- No special hardware necessary
- Safe inputs can operate on safe outputs on *local* or across the *couple* network
- Safe & standard modules can be on any *local* network and the *couple* network

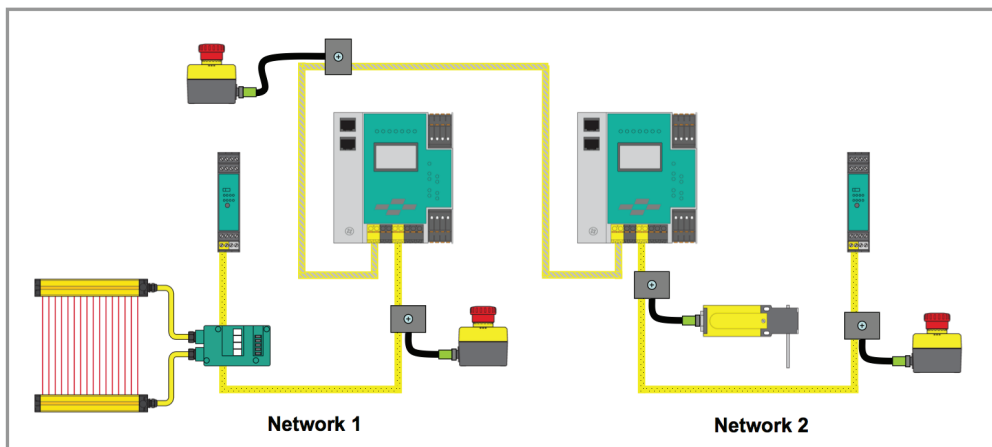

COMPLETE SOLUTIONS FROM A SINGLE SUPPLIER

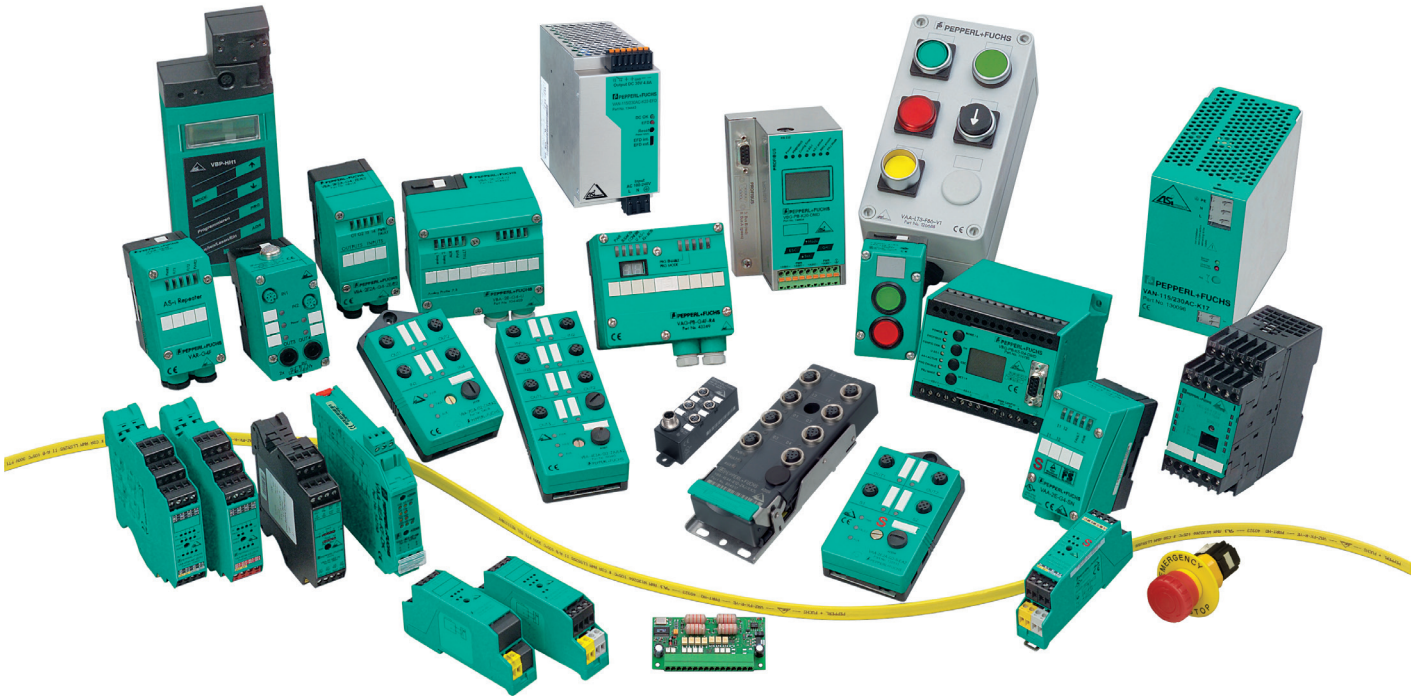

For more information on our AS-Interface safety solutions, visit:

www.pepperl-fuchs.com

Contact

Pepperl+Fuchs Inc.
1600 Enterprise Parkway
Twinsburg, Ohio 44087 · USA
Tel. +1 330 486-0001 · Fax +1 330 405-4710
E-mail: fa-info@us.pepperl-fuchs.com

Worldwide Headquarters

Pepperl+Fuchs GmbH · Mannheim · Germany
E-mail: fa-info@de.pepperl-fuchs.com

USA Headquarters

Pepperl+Fuchs Inc. · Twinsburg · USA
E-mail: fa-info@us.pepperl-fuchs.com

Asia Pacific Headquarters

Pepperl+Fuchs Pte Ltd · Singapore
Company Registration no. 199003130E
E-mail: fa-info@sg.pepperl-fuchs.com

www.pepperl-fuchs.com

 **PEPPERL+FUCHS**
SENSING YOUR NEEDS