

Features

- 2-channel isolated barrier
- 24 V DC supply (Power Rail)
- Dry contact or NAMUR inputs
- Input frequency 1 mHz ... 1 kHz
- Current output 0/4 mA ... 20 mA
- Relay and transistor output
- Start-up override
- Configurable by **PACTware™** or keypad
- Line fault detection (LFD)

Function

This isolated barrier is used for intrinsic safety applications. It analyzes 2 digital signals (NAMUR sensor/mechanical contact) from a hazardous area and functions as a rotation direction indicator, slip monitor, frequency monitor or synchronization monitor.

Each proximity sensor or switch controls a passive transistor output. The 2 relay outputs indicate if the input signal is above or below the trip value or the rotational direction.

The analog output can be programmed to be proportional to the input frequency or slip differential.

The unit is easily programmed by the use of a keypad located on the front of the unit or with the **PACTware™** configuration software.

Line fault detection of the field current is indicated by a red LED and through the collective error output via Power Rail.

For additional information, refer to the manual and www.pepperl-fuchs.com.

Assembly

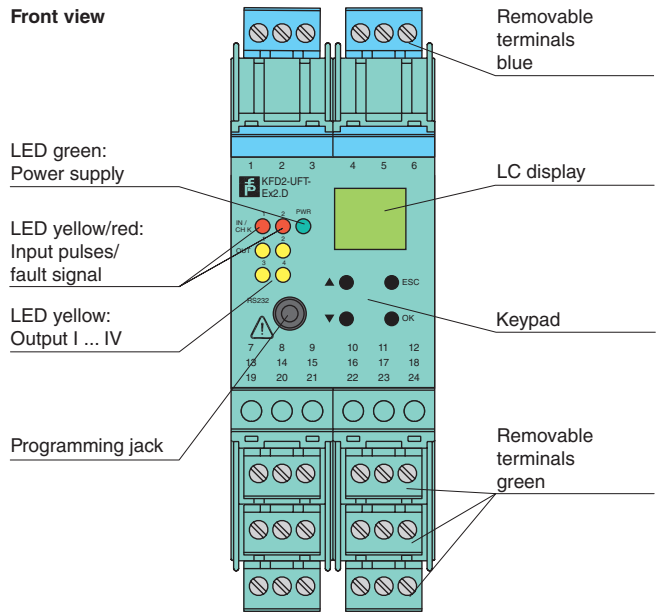

Connection

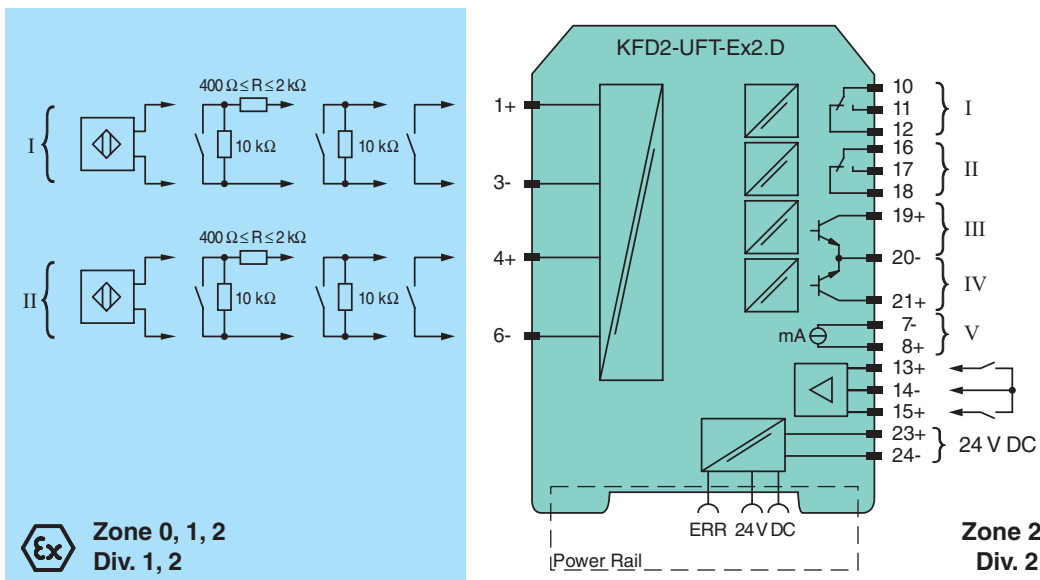

Release date 2010-11-04 14:10 Date of issue 2010-11-10 188375_ENG.xml

General specifications	
Signal type	Digital input
Supply	
Connection	terminals 23+, 24- or power feed module/Power Rail
Rated voltage	20 ... 30 V DC
Rated current	approx. 130 mA
Power loss	2.2 W
Power consumption	2.5 W
Input	
Connection	input I: terminals 1+, 3- input II: terminals 4+, 6- input III: terminals 13+, 14- (control input 1) input IV: terminals 15+, 14- (control input 2)
Input I, II	acc. to EN 60947-5-6 (NAMUR)
Open circuit voltage/short-circuit current	8.2 V / 10 mA
Pulse duration	≥ 250 μs , overlap on direction of rotation signal: ≥ 125 μs
Input frequency	rotation direction monitoring 0.001 ... 1000 Hz slip monitoring 10 ... 1000 Hz
Lead monitoring	breakage I ≤ 0.15 mA; short-circuit I > 6.5 mA
Input III, IV	
Active/Passive	I > 4 mA (for min. 100 ms) / I < 1.5 mA
Open circuit voltage/short-circuit current	18 V / 5 mA
Output	
Connection	output I: terminals 10, 11, 12 output II: terminals 16, 17, 18 output III: terminals 19+, 20- output IV: terminals 21+, 20- output V: terminals 7-, 8+
Collective error message	Power Rail
Output I, II	signal , relay
Contact loading	250 V AC / 2 A / cos φ ≥ 0.7 ; 40 V DC / 2 A
Mechanical life	5 x 10 ⁷ switching cycles
Energized/De-energized delay	approx. 20 ms / approx. 20 ms
Output III and IV	signal , electronic output, passive
Contact loading	40 V DC
Signal level	1-signal: (external voltage) - 2.5 V max. for 10 mA or 3 V max. for 100 mA (100 mA, short-circuit proof) -2.5 V (50 mA, short-circuit/overload proof) 0-signal: switched off (off-state current ≤ 10 μA)
Output V	analog
Current range	0 ... 20 mA or 4 ... 20 mA
Open loop voltage	max. 24 V DC
Load	max. 650 Ω
Fault signal	downscale I ≤ 3.6 mA, upscale I ≥ 21.5 mA (acc. NAMUR NE43)
Programming interface	
Connection	programming socket
Interface	RS 232
Transfer characteristics	
Input I and II	
Measurement range	0.001 ... 1000 Hz
Resolution	slip monitoring: 1% frequency measurement: 0,1% of measured value; but >0.001Hz
Accuracy	slip monitoring: 1% frequency measurement: 0.5% of measured value; but >0.001Hz
Measuring time	frequency measurement: < 100 ms
Influence of ambient temperature	0.003 %/K (30 ppm)
Output I, II	
Response delay	≤ 200 ms
Output V	
Resolution	< 10 μA
Accuracy	< 30 μA
Influence of ambient temperature	0.005 %/K (50 ppm)
Electrical isolation	
Input III, IV/power supply and collective error	functional insulation acc. to IEC 62103, rated insulation voltage 50 V _{eff}
Output I, II/other circuits	reinforced insulation according to IEC 61140, rated insulation voltage 300 V _{eff}
Mutual output I, II, III	reinforced insulation according to IEC 61140, rated insulation voltage 300 V _{eff}
Mutual output I, II, IV,	reinforced insulation according to IEC 61140, rated insulation voltage 300 V _{eff}

Release date 2010-11-04 14:10 Date of issue 2010-11-10 188375_ENG.xml

Output III, IV/power supply and collective error	basic insulation according to IEC 62103, rated insulation voltage 50 V _{eff}
Output III, IV/input III, IV	basic insulation according to IEC 62103, rated insulation voltage 50 V _{eff}
Output III, IV/V	basic insulation according to IEC 62103, rated insulation voltage 50 V _{eff}
Output V/power supply and collective error	functional insulation acc. to IEC 62103, rated insulation voltage 50 V _{eff}
Interface/power supply and collective error	functional insulation acc. to IEC 62103, rated insulation voltage 50 V _{eff}
Interface/Output III, IV	basic insulation according to IEC 62103, rated insulation voltage 50 V _{eff}
Directive conformity	
Electromagnetic compatibility	
Directive 2004/108/EC	EN 61326-1:2006
Low voltage	
Directive 2006/95/EC	EN 50178:1997
Conformity	
Insulation coordination	IEC 62103
Electrical isolation	IEC 62103
Electromagnetic compatibility	NE 21
Protection degree	IEC 60529
Protection against electric shock	IEC 61140
Input	EN 60947-5-6
Ambient conditions	
Ambient temperature	-20 ... 60 °C (-4 ... 140 °F)
Mechanical specifications	
Protection degree	IP20
Mass	300 g
Dimensions	40 x 119 x 115 mm (1.6 x 4.7 x 4.5 in) , housing type C3
Data for application in connection with Ex-areas	
EC-Type Examination Certificate	TÜV 99 ATEX 1471 , for additional certificates see www.pepperl-fuchs.com
Group, category, type of protection	⊕ II (1)GD, I (M1) [Ex ia] IIC, [Ex iaD], [Ex ia] I (-20 °C ≤ T _{amb} ≤ 60 °C)
Supply	
Maximum safe voltage U _m	40 V DC (Attention! U _m is no rated voltage.)
Input I and II	terminals 1+, 3-; 4+, 6- Ex ia IIC, Ex iaD
Voltage U _o	10.1 V
Current I _o	13.5 mA
Power P _o	34 mW (linear characteristic)
Input III and IV	terminals 13+, 14-; 15+, 14- non-intrinsically safe
Maximum safe voltage U _m	40 V (Attention! U _m is no rated voltage.)
Output I, II	terminals 10, 11, 12; 16, 17, 18 non-intrinsically safe
Maximum safe voltage U _m	253 V (Attention! The rated voltage can be lower.)
Contact loading	253 V AC/2 A/cos φ > 0.7; 40 V DC/2 A resistive load (TÜV 99 ATEX 1471)
Output III and IV	terminals 19, 20, 21 non-intrinsically safe
Maximum safe voltage U _m U _m	40 V DC (Attention! U _m is no rated voltage.)
Output V	terminals 8+, 7- non-intrinsically safe
Maximum safe voltage U _m U _m	40 V DC (Attention! U _m is no rated voltage.)
Interface	RS 232
Maximum safe voltage U _m	40 V (Attention! U _m is no rated voltage.)
Statement of conformity	TÜV 02 ATEX 1885 X , observe statement of conformity
Group, category, type of protection, temperature classification	⊕ II 3G Ex nA nC IIC T4
Output I, II	
Contact loading	50 V AC/2 A/cos φ > 0.7; 40 V DC/1 A resistive load
Electrical isolation	
Input I, II/other circuits	safe electrical isolation acc. to IEC/EN 60079-11, voltage peak value 375 V
Directive conformity	
Directive 94/9/EC	EN 60079-0:2006, EN 60079-11:2007, EN 60079-15:2005, EN 60079-26:2007, EN 61241-0:2006, EN 61241-11:2006
International approvals	
FM approval	
Control drawing	16-538FM-12
General information	
Supplementary information	EC-Type Examination Certificate, Statement of Conformity, Declaration of Conformity, Attestation of Conformity and instructions have to be observed where applicable. For information see www.pepperl-fuchs.com.

Release date 2010-11-04 14:10 Date of issue 2010-11-10 188375_ENG.xml

Function

The device processes two input frequencies up to a max. of 1 kHz. The following functions are provided by the device:

- Frequency measurement with freely adjustable trip value monitoring for high and low alarm as well as for frequency-current-conversion (0/4 mA ... 20 mA)
- Slip monitoring: The slip is calculated from the two input frequencies at channel I and II. If the freely parameterisable trip value is exceeded, the respective output switches.
- Rotation direction signalling: The rotation direction is evaluated from the two input signals with the same frequency and a phase shift of 90°. The corresponding outputs switch according to the direction of rotation.
- The frequency monitoring can be used in combination with rotation direction signalling or slip monitoring.
- Synchronisation monitor: The synchronisation monitor compares the pulse counts of the two inputs. If the measured difference in the pulses is greater than the programmed value the corresponding outputs are switching.

The two electronic outputs serve to repeat the input signals.

Accessories

Power feed module KFD2-EB2

The power feed module is used to supply the devices with 24 V DC via the Power Rail. The fuse-protected power feed module can supply up to 100 individual devices depending on the power consumption of the devices. A galvanically isolated mechanical contact uses the Power Rail to transmit collective error messages.

Power Rail UPR-03

The Power Rail UPR-03 is a complete unit consisting of the electrical inset and an aluminium profile rail 35 mm x 15 mm. To make electrical contact, the devices are simply engaged.

Profile Rail K-DUCT with Power Rail

The profile rail K-DUCT is an aluminum profile rail with Power Rail insert and two integral cable ducts for system and field cables. Due to this assembly no additional cable guides are necessary.



Attention

Power Rail and Profile Rail must not be fed via the device terminals of the individual devices!

PACT^{ware}™

Device-specific drivers (DTM)

Adapter K-ADP1

Programming adapter for parameterisation via the serial RS 232 interface of a PC/Notebook

For programming, please use the new version of adapter K-ADP1 (part no. 181953, connector length 14mm). When using the previous version K-ADP1 (connector length 18 mm) the plug is exposed by approx. 3 mm. The function is not affected.

Adapter K-ADP-USB

Programming adapter for parameterisation via the serial USB interface of a PC/Notebook