

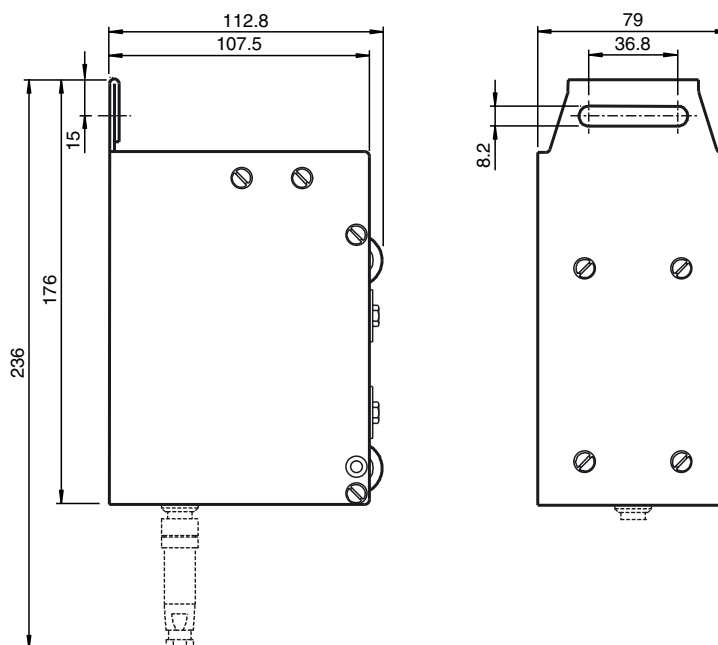

Dimensions



Model number

WCS2-GT09-P1-C

WCS2 guiding trolley

Features

- Ensures the optimum alignment of reading head and code rail
- With prefitted mounting plate for reading head
- Cleaning brushes can be applied
- Powder coated
- Plastic rollers

Accessories

WCS2-GT-WL-P

Roller

Matching system components

WCS2-PS1-C

WCS2 profile rail, coated

WCS2-PS1

WCS2 profile rail

WCS2-PS1-2,5M

WCS2 profile rail

WCS2-PS1-8FT

WCS2 profile rail

Technical data

General specifications

Passage speed $v \leq 8$ m/s

Ambient conditions

Operating temperature $-40 \dots 70$ °C ($-40 \dots 158$ °F)

Mechanical specifications

Bending radius ≥ 1000 mm

Material
Metal sheet (steel), zinc-plated
Plastic rollers

Mass 1000 g

Coating powder coated , 100 μ m