

Inductive sensor

NCN25-F35-A2-250-V1

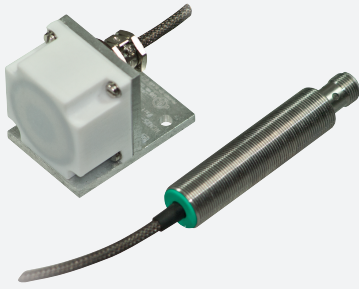

- Comfort series
- Extended temperature range of sensor component
0 ... 250 °C (0 ... 482 °F)
- 10 m cable between sensor and amplifier with metal case
- Suitable for drag chains and abrasion resistant
- Minimum bending radius of 30 cm for movable laying



Dimensions

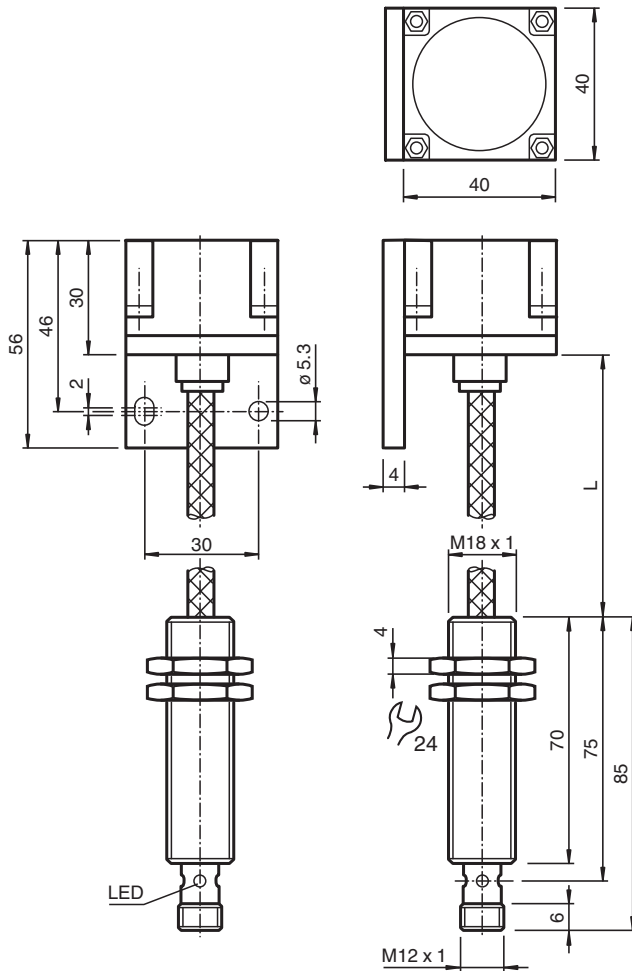

Technical Data

General specifications

Switching function	complementary
Output type	PNP

Release date: 2022-09-29 Date of issue: 2022-09-29 Filename: 187479_eng.pdf

Refer to "General Notes Relating to Pepperl+Fuchs Product Information".

Pepperl+Fuchs Group
www.pepperl-fuchs.com

USA: +1 330 486 0001
fa-info@us.pepperl-fuchs.com

Germany: +49 621 776 1111
fa-info@de.pepperl-fuchs.com

Singapore: +65 6779 9091
fa-info@sg.pepperl-fuchs.com

PF PEPPERL+FUCHS

Technical Data

Rated operating distance	s_n	25 mm
Installation		flush mountable
Output polarity		DC
Assured operating distance	s_a	0 ... 20 mm
Reduction factor r_{Al}		0.5
Reduction factor r_{Cu}		0.5
Reduction factor r_{304}		0.6 ... 1
Output type		4-wire
Mounting angle		Al
Amplifier housing		Stainless steel
Nominal ratings		
Operating voltage	U_B	10 ... 30 V
Switching frequency	f	0 ... 20 Hz
Hysteresis	H	0.3 ... 5 typ. 2 %
Reverse polarity protection		reverse polarity protected
Short-circuit protection		pulsing
Voltage drop	U_d	≤ 3 V
Operating current	I_L	0 ... 200 mA
No-load supply current	I_0	≤ 25 mA
Time delay before availability	t_v	≤ 20 ms
Switching state indicator		Multihole-LED, yellow
Functional safety related parameters		
MTTF _d		7515 a
Mission Time (T_M)		20 a
Diagnostic Coverage (DC)		0 %
Compliance with standards and directives		
Standard conformity		
Standards		EN 60947-5-2:2007 IEC 60947-5-2:2007
Approvals and certificates		
UL approval		cULus Listed, General Purpose, Class 2 Power Source
CCC approval		CCC approval / marking not required for products rated ≤ 36 V
Ambient conditions		
Ambient temperature		0 ... 250 °C (32 ... 482 °F)
Mechanical specifications		
Connection type		Connector plug M12 x 1 , 4-pin
Cable version		PFA cable, with armour of stainless steel
Core cross section		3 x 0.34 , screened
Housing material		PTFE / Al / 1.4305 / AISI 303
Sensing face		PTFE
Degree of protection		amplifier IP67 sensor IP40
Cable length		L = 10 m
Note		- amplifier 0 °C ... 70 °C - $r_{1.4305}$ dep. on thickness of measurement plate d: $r_{1.4305} = 1$ for $d < 1$ mm Additional accessory: Protective cover SH-F35 is available for use in areas where there is moisture and as a means of mechanical protection.

Connection

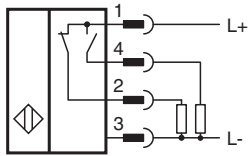

Connection Assignment



Wire colors in accordance with EN 60947-5-2

1	BN	(brown)
2	WH	(white)
3	BU	(blue)
4	BK	(black)

Mounting

Installation Conditions

The sensor consists of a cylindrical amplifier part and the cubic sensor head. Both main components are inseparably connected with a high temperature cable.

The following installation conditions shall be observed:

- Install the amplifier in the low temperature area of the plant. Only the sensor head may be exposed to high temperatures.
- Unwind the high-temperature cable for operation, observing the permissible minimum bending radius.
- Avoid kinking or pinching the high temperature cable.
- If the minimum bending radius is not exceeded, the high-temperature cable can be assumed to be suitable for conveyor chains with a maximum of 1 million movement cycles.
- Mount the sensor so that the front edge of a metallic mounting base does not overhang the front edge of the sensor head. Flush mount of the sensor head on one side is possible. A back-flush installation of the sensors in metallic environment must be avoided at all costs.
- Observe the maximum tightening torque of 30 Nm for the fastening nuts on the cylindrical amplifier part.

Note

The screws on the sensor head are secured against loosening. The sensor head cannot be opened in a damage-free manner.

Caution!

Function failure in case of mechanical knocks!

Avoid mechanical knocks to the sensor head. The ferrite core of the sensor coil is hidden directly under the housing cover.

Knocks on the sensor head can lead to fracture of the ferrite core and thus to failure of the sensor.

Caution!

Functional failure if there is buckling/crushing stress on the high-temperature cable!

If the high-temperature cable experiences kinking or crushing stress, the internal structure of the cable is immediately altered to such an extent that this can lead to a loss of function of the sensor.

Protecting the sensor from dripping water

In the form of the SH-F35 accessory, Pepperl+Fuchs offers a protective cover for the sensor head of the F35 series. The protective cover is simply plugged onto the sensor head and provides limited protection against dripping water. The SH-F35 protective cover additionally increases the protection of the sensor head against external mechanical impacts.

Installation

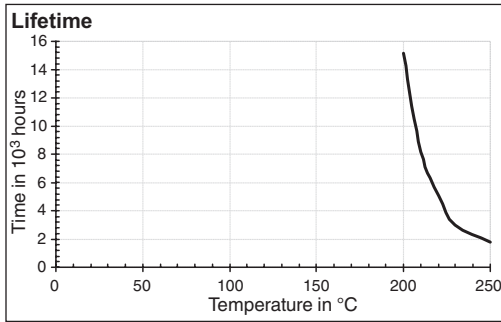

Installation:

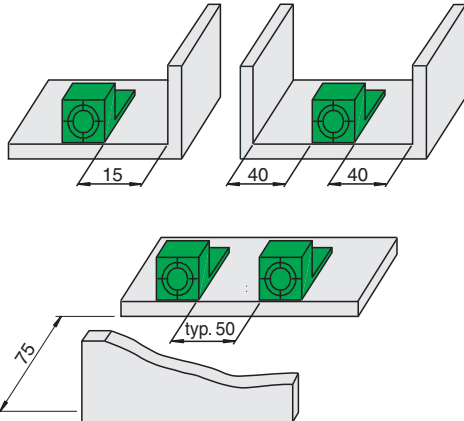

Accessories:

Protective Cover SH-F35

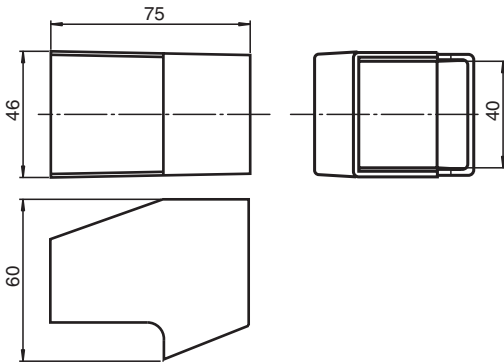

Accessories

	V1-W-2M-PUR	Female cordset single-ended M12 angled A-coded, 4-pin, PUR cable grey
	V1-G-2M-PUR	Female cordset single-ended M12 straight A-coded, 4-pin, PUR cable grey
	SH-F35	Protective cap for mechanical protection and for use in applications in conditions where moisture is present.
	BF 18	Mounting flange, 18 mm

Release date: 2022-09-29 Date of issue: 2022-09-29 Filename: 187479_eng.pdf