



Loop detector LC10-2-D 24 VAC

- Sensor system for vehicle detection
- Complete control interface for inductive loops laid beneath the surface
- Reliable detection with long service life
- Boost function for increasing sensitivity
- Test function
- Version with 2 loop channels
- Version with direction detection

Universal sensor system for detecting vehicles



Function

Together with the inductive loops laid beneath the surface, the loop detectors form a universal sensor system for detecting vehicles. Vehicles that enter the inductive loop change the resonant frequency. The microprocessor in the loop detector measures and analyzes this frequency change. The analysis is automatically and periodically adjusted to the respective loop, ensuring that any changes in the loop inductance caused by temperature, humidity, or component age are automatically compensated for.

Dimensions

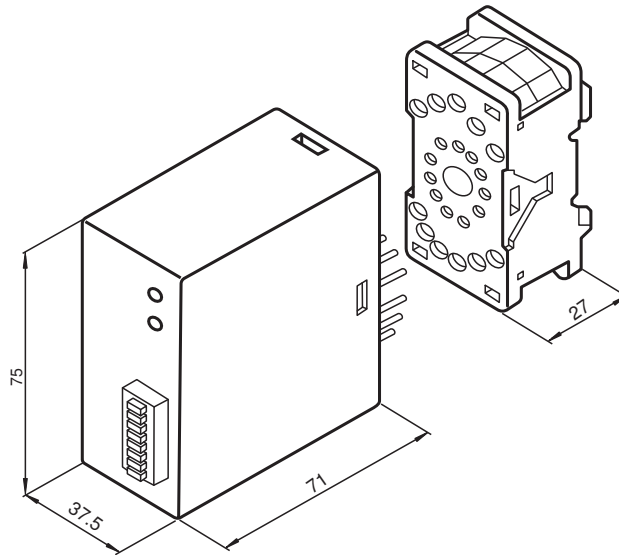

Technical Data

General specifications		
Marking		CE
Operating mode		Continuous signal / Direction detection
Functional safety related parameters		
MTTF _d		306 a
Mission Time (T _M)		20 a
Indicators/operating means		
Control elements		DIP-switch
Switching state		LED
Electrical specifications		
Operating voltage	U _B	24 V AC (galvanically isolated from loop)
Ripple		-15 %/+10 %
Power consumption	P ₀	2.2 VA
Calibration time		2 s
Loop inductivity		100 ... 1000 μH
Loop frequency		20 ... 120 kHz
Input		
Number of channels		2
Output		
Signal output		2 relay outputs
Switching voltage		250 V AC
Switching current		6 A
Pulse length		period
Response time		200 ms
Ambient conditions		
Ambient temperature		-20 ... 70 °C (-4 ... 158 °F)
Storage temperature		-40 ... 70 °C (-40 ... 158 °F)
Mechanical specifications		
Degree of protection		IP30
Connection		Plug socket ; 11-pin Terminal connection ≤ 1.5 mm ²

Connection Assignment

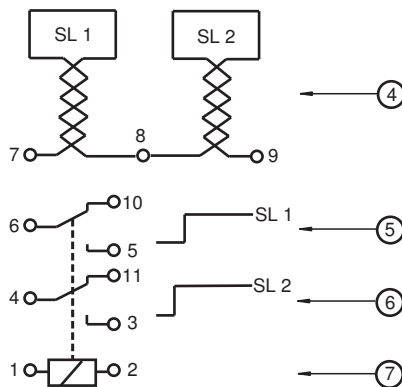

Number	Explanation	Connector terminals
4	Loop connection, Loops 1/2	7/8 = Loop 1 8/9 = Loop 2
5	Signal output, Loop 1	5/6 = NO 6/10 = NC
6	Signal output, Loop 2	3/4 = NO 4/11 = NC
7	Operating voltage	1/2

Release date: 2020-10-08 Date of issue: 2020-10-08 Filename: 190925_eng.pdf

Assembly

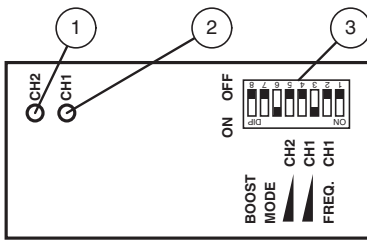

1	LED indicator loop 2
2	LED indicator loop 1
3	DIP switch

Characteristic Curve

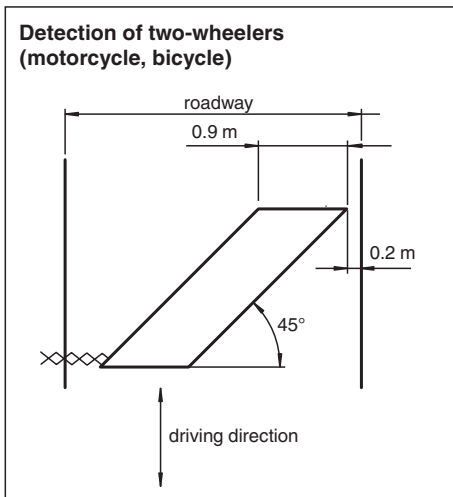
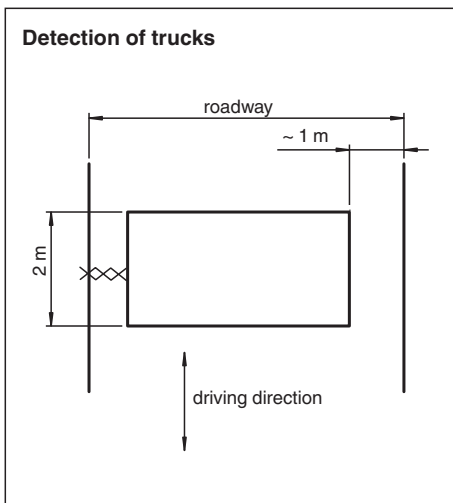
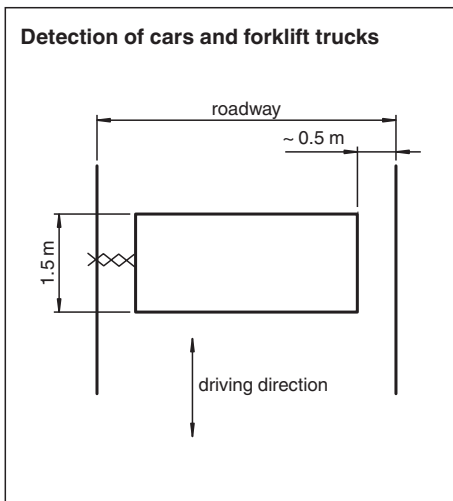

Release date: 2020-10-08 Date of issue: 2020-10-08 Filename: 190925_eng.pdf

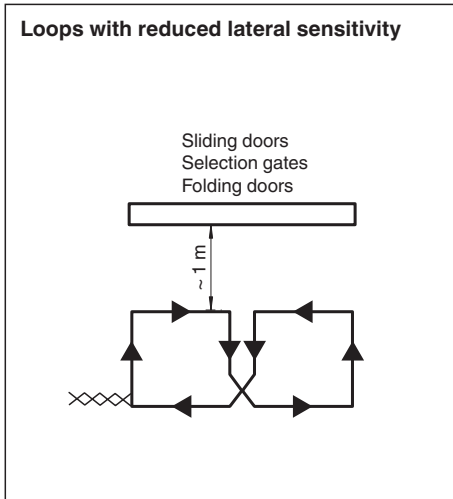

Application

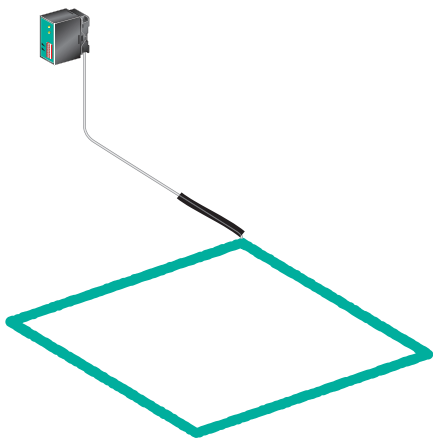

Release date: 2020-10-08 Date of issue: 2020-10-08 Filename: 190925_eng.pdf

Refer to "General Notes Relating to Pepperl+Fuchs Product Information".

Pepperl+Fuchs Group
www.pepperl-fuchs.com

USA: +1 330 486 0001
fa-info@us.pepperl-fuchs.com

Germany: +49 621 776 1111
fa-info@de.pepperl-fuchs.com

Singapore: +65 6779 9091
fa-info@sg.pepperl-fuchs.com

Settings

Sensitivity:

The response sensitivity of the loop detector can be set to three levels using switches 3 and 4 for loop 1, and switches 5 and 6 for loop 2.

Switch 3 or 5	Switch 4 or 6	Sensitivity
OFF	ON	Low
ON	OFF	Medium
ON	ON	High

Loop evaluation is disabled when the switches are set to "OFF", "OFF".

Frequency switch:

The loop frequency for loop 1 can be set to four levels using switches 1 and 2.

Switch 1	Switch 2	Frequency
OFF	OFF	Fundamental frequency f
ON	OFF	f – 10%
OFF	ON	f – 15%
ON	ON	f – 20%

Once frequency switches 1 and 2 have been activated, the loop in the "OFF", "OFF" position for switches 3 and 4 must be recalibrated.

Operating mode switch:

Switches 7 and 8 are used to set the following operating modes:

Switch 7	Switch 8	Description
OFF	-	Loop assignment status output
ON	-	Direction monitoring*
-	ON	Sensitivity boost

*A signal is issued depending on the order in which the loops are assigned. If loop 1 is assigned before loop 2, a switching signal is issued only for loop 1. The signal output for loop 2 remains blocked until both loops are free again. If loop 2 is assigned before loop 1, a switching signal is issued only for loop 2. The signal output for loop 1 remains blocked until both loops are free again.

The sensitivity boost is used to detect vehicles with high bodies, such as heavy goods vehicles.

Automatic calibration:

If the operating voltage is supplied to the device, the loop is automatically calibrated. The output relays are switched to the "Loop not assigned" switch position. The calibration process takes two seconds; the device then is ready for operation.

Automatic calibration happens when sensitivity switches 3 and 4 (loop 1) and switches 5 and 6 (loop 2) are switched to the "OFF" position, and then changed to a different switch position. The calibration process can be performed separately for loop 1 and for loop 2.

Displays

LED 1/2 indicates the loop assignment status (loop 1 occupied = LED 1 on; loop 2 occupied = LED 2 on). A fault in the loop caused by a short circuit or interruption, and loop inductance that falls outside of the permitted range, are indicated by the relevant LED flashing.

Test function

The loop detector is equipped with an integrated test function, which allows an optimal adjustment of loop frequency and

Release date: 2020-10-08 Date of issue: 2020-10-08 Filename: 190925_eng.pdf

Refer to "General Notes Relating to Pepperl+Fuchs Product Information".

sensitivity without additional measuring instrumentation.

Displaying the recommended sensitivity:

To do this, a vehicle must enter the loop. The loop detector measures and saves the change in frequency that is generated. The recommended sensitivity is indicated by LED 1 for loop 1 flashing when switches 3 and 4 are switched to OFF. The recommended sensitivity is indicated by LED 2 for loop 2 flashing when switches 5 and 6 are switched to OFF.

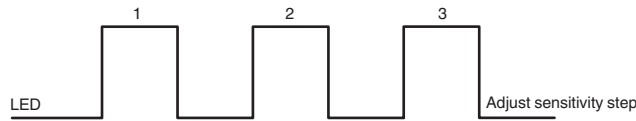

Measuring the loop frequency:

The loop frequency can be measured using the LED. To do this, switch switches 3 and 4 from "OFF" to "ON". The LED indicates the loop frequency via a signal sequence:

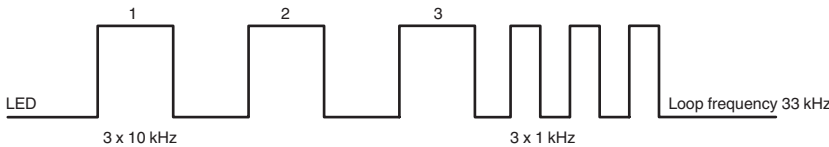

Loop fault:

In the event of an interruption or short circuit, the LED display flashes continuously and the switch contact changes to "Loop assigned" status.

Function Principle

The loop detectors are control units that are fully functional without the need for any other auxiliary equipment once the power supply and an inductive loop have been connected. The inductive loop laid below the surface forms the inductor of a high-frequency oscillating circuit. The metal parts of a vehicle that enters or is located in this wired loop cause the frequency of the oscillation circuit to change. This frequency change is analyzed by the loop detector, and the outputs, which are zero-potential relay contacts, can switch. The switching outputs are relay contacts with a high switching power that can directly control contactors, valves and alternating current motors. The dimensions of the detection area can be adjusted by changing the size and shape of the inductive loops.

Application

- Selective vehicle detection
- Opening impulse sensor for automatic gates and barrier systems
- Presence checks for vehicles
- Direction-specific vehicle checks
- Controlling traffic light and vehicle detection systems
- Ticket detection in parking garages
- Managing tasks in automatic conveyor systems

Release date: 2020-10-08 Date of issue: 2020-10-08 Filename: 190925_eng.pdf