

Active infrared scanner

PROSCAN-T-3529

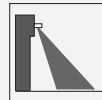

- Version with E1 approval
- Fan-shaped detection field with up to 12 beams
- Adjustable detection fields for different door widths
- Automatic drift compensation

Multi-beam sensor with self-programming function for monitoring large areas with e1 approval



Function

The compact ProScan energetic light scanner operates using an integrated source of infrared light and creates a fan-shaped detection field consisting of a maximum of 12 independent light beams. Since the beam intensifies toward the center of the fan, the area around the closing edges in particular is monitored virtually seamlessly. The sensors are self-programming and automatically adapt to any environment, learn the environment, and even automatically adapt to subsequent changes. Other notable features include the high level of sensitivity, ambient light immunity and compensation of long-term drift. This function guarantees reliable long-term use, even in dirty, rainy or snowy conditions.

Dimensions

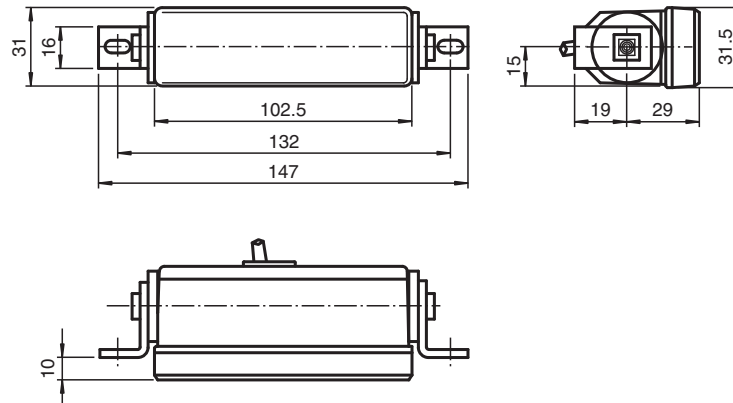

Technical Data

General specifications

Detection field	total field: 2300 mm x 80 mm left/right field: 1150 mm x 80 mm center field: 1000 mm x 80 mm II (installation height: 2 m)
Light source	12 x IRED
Light type	modulated infrared light
Teach-in time	approx. 4 s
Open time	3 s / 10 s, programmable

Functional safety related parameters

MTTF _d	630 a
Mission Time (T _M)	20 a
Diagnostic Coverage (DC)	60 %

Indicators/operating means

Function indicator	LED red: on for object detection, flashes during teaching phase
Control elements	Programmable switch for switching type, open time, detection field
Factory setting	Right-field sensing with 6 beams

Electrical specifications

Operating voltage	U _B	12 ... 38 V DC
Ripple		10 %
No-load supply current	I ₀	100 mA

Output

Switching type	Output active / inactive programmable
Signal output	1 PNP, short-circuit protected, reverse polarity protected, open collector

Release date: 2021-02-24 Date of issue: 2021-02-24 Filename: 192676_eng.pdf

Refer to "General Notes Relating to Pepperl+Fuchs Product Information".

Pepperl+Fuchs Group
www.pepperl-fuchs.com

USA: +1 330 486 0001
fa-info@us.pepperl-fuchs.com

Germany: +49 621 776 1111
fa-info@de.pepperl-fuchs.com

Singapore: +65 6779 9091
fa-info@sg.pepperl-fuchs.com

 PEPPERL+FUCHS

Technical Data

Switching voltage	38 V DC
Switching current	200 mA
Response time	< 50 ms
De-energized delay	t _{off} 200 ms
Compliance with standards and directives	
Standard conformity	
Product standard	EN 60947-5-2
Standards	EN 50155 Chapter 12.2.3 / 12.2.5 / 12.2.7 / 12.2.8 / 12.2.11 / 12.2.14 Details see test report
Flammability	Flame retardant in accordance with UN/ECE-R118 or ISO 14572
Approvals and certificates	
UN/ECE Regulation No. 10 (E1)	Type-approval number: 046982
Ambient conditions	
Ambient temperature	-25 ... 60 °C (-13 ... 140 °F)
Storage temperature	-40 ... 70 °C (-40 ... 158 °F)
Mechanical specifications	
Mounting height	1000 ... 2500 mm
Degree of protection	IP52
Connection	AMP connector 6-pin , 2 m fixed cable
Material	
Housing	ABS
Optical face	PMMA
Mass	approx. 100 g

Connection Assignment



Assembly

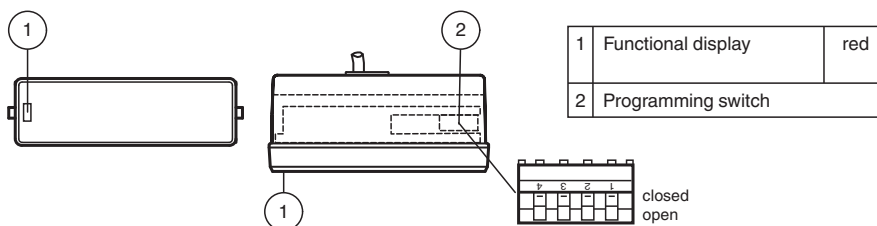

Release date: 2021-02-24 Date of issue: 2021-02-24 Filename: 192676_eng.pdf

Characteristic Curve

Timing diagram Proscan

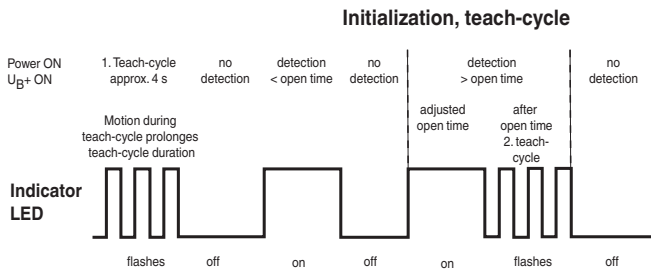

Switch 4 ON



Switch 4 OFF

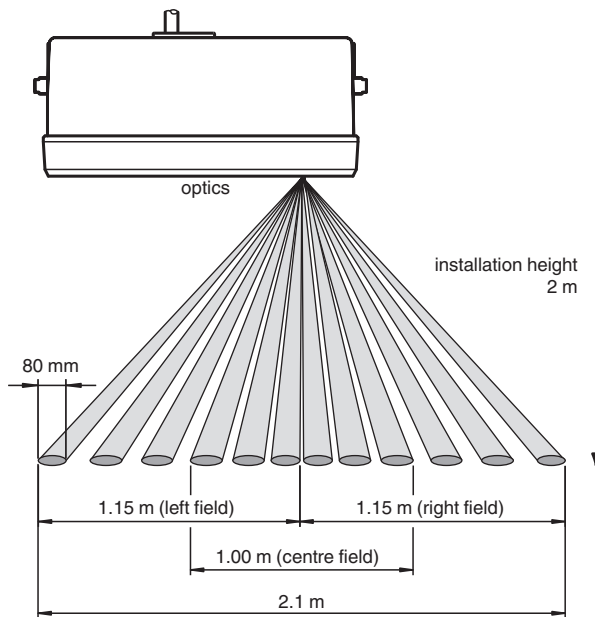

Release date: 2021-02-24 Date of issue: 2021-02-24 Filename: 192676_eng.pdf

Application



Accessories

	UP-Einbaurahmen	Mounting frame for sensors in the AIR30 and PROSCAN series
---	------------------------	--

Release date: 2021-02-24 Date of issue: 2021-02-24 Filename: 192676_eng.pdf

Refer to "General Notes Relating to Pepperl+Fuchs Product Information".

Pepperl+Fuchs Group
www.pepperl-fuchs.com

USA: +1 330 486 0001
fa-info@us.pepperl-fuchs.com

Germany: +49 621 776 1111
fa-info@de.pepperl-fuchs.com

Singapore: +65 6779 9091
fa-info@sg.pepperl-fuchs.com

Programming options

The programming switch can be accessed by carefully removing the cover with the lens assembly from the housing. A small slot-head screwdriver can be used to carefully lift off the cover by the slots located on the sides of the cover.

Each switch is on when the switch position is down (ON); if the switch position is up, then the switch is switched off (OFF).

The table below shows the various programming options.

Switch	Output active during detection	Output inactive during detection	Open Time 10 seconds	Open Time PROSCAN 3 min PROSCAN-T 3 seconds
4	ON	OFF		
3			ON	OFF

Detecting field at installation height of 2000 mm				
Switch	2300 mm x 80 mm Full field	1150 mm x 80 mm Left field	1150 mm x 80 mm Right field	1000 mm x 80 mm Center field
2	OFF	OFF	ON	ON
1	OFF	ON	OFF	ON

Function Principle

The ProScan is a 12-beam energetic light scanner based on the principles of active infrared. The beams, which are switched independently, enable the sensor to fan out across an extremely wide and narrow detection field in the area of the door.

The clearly defined, fan-shaped detection field on the ProScan can be set manually in four areas: half fan to the right, half fan to the left, central fan and full detection field.

Immediately after being switched on for the first time, the ProScan programs the reflected pattern of the detected background as the reference signal. During this process, the ProScan automatically adapts to the relevant installation and assembly environment. Since each of the individual light beams on the ProScan independently programs its specific reception level, there is no need to manually configure complex sensitivity settings.

Once the programming phase is complete, the light reflected from each of the 12 light beams is evaluated. Each time there is a difference between the reflected value of an individual light beam and the reference signal, a switching process is initiated.

"Open Time" Function

The ProScan is a self-programming device, and automatically adjusts to changes in its environment. If the ProScan detects a stationary object that does not correspond to the programmed reference signal (for example, a suitcase), ProScan interprets this as a permanent change in the environment and initiates a new self teach-in process after a preset time (referred to as "Open Time") has elapsed. Open Time can be adjusted to meet customer application requirements.

"Suitcase" Function

After a background has been changed, the ProScan "Suitcase" function allows the reference to be adjusted back to the original background. Once a self-taught object, such as a suitcase, is removed from the detection field again, ProScan returns to the original reference. A new learning process is not required.

Compensating for long-term drifts

The ProScan is able to compensate for long-term drifts. Using this function, changes to the ground reflectance (for example, caused by rain or snow), as well as temperature fluctuations and dirt on the optical surface or ground are automatically compensated for.

Test input (optional)

Using the integrated test input, the overall function of the ProScan can be reliably checked by testing all 12 light beams simultaneously.

Application

- Closing edge protection on automatic sliding doors, for example sliding doors in shopping centers, public buildings and office buildings
- Version T with e1 approval: Closing edge protection on automatic doors on public transport vehicles, such as buses and trains
- Threshold monitoring on revolving doors