



Optical reading head PCV100I-F200-R4-V19

- RS-485 interface
- Non-contact positioning on Data Matrix code tape
- Travel ranges up to 10 km, in X and Y direction
- Mechanically rugged: no wearing parts, long operating life, maintenance-free
- High resolution and precise positioning, especially for facilities with curves and switch points as well as inclines and declines.
- Infrared light

Read head for incident light positioning system



Dimensions

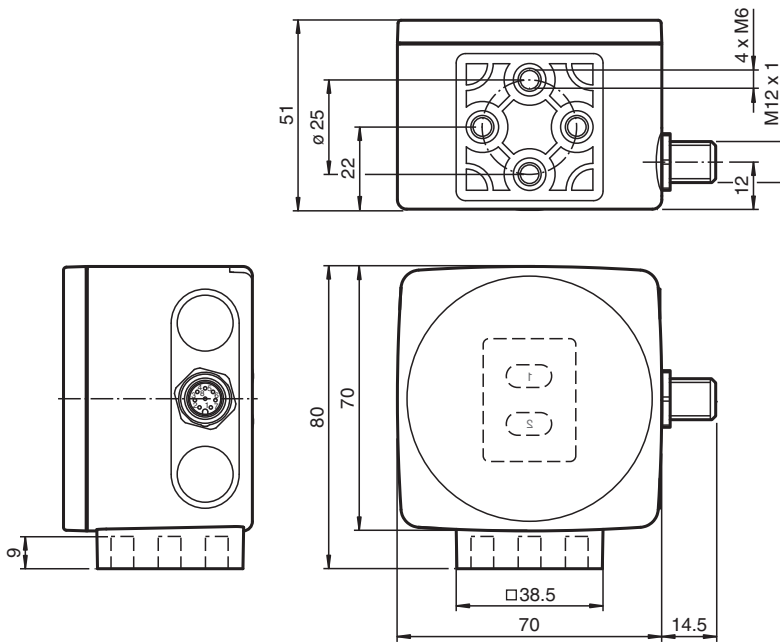

Technical Data

General specifications

Passage speed	v	≤ 8 m/s
Measuring range		max. 10000 m
Light type		Integrated LED lightning , infrared
Scan rate		40 s ⁻¹
Read distance		100 mm
Depth of focus		± 20 mm
Reading field		50 mm x 30 mm
Ambient light limit		100000 Lux
Resolution		± 0.1 mm

Release date: 2024-02-07 Date of issue: 2024-02-07 Filename: 242706_eng.pdf

Refer to "General Notes Relating to Pepperl+Fuchs Product Information".

Pepperl+Fuchs Group
www.pepperl-fuchs.com

USA: +1 330 486 0001
fa-info@us.pepperl-fuchs.com

Germany: +49 621 776 1111
fa-info@de.pepperl-fuchs.com

Singapore: +65 6779 9091
fa-info@sg.pepperl-fuchs.com

PF PEPPERL+FUCHS

Technical Data

Nominal ratings			
Camera			
Type		CMOS , Global shutter	
Processor			
Clock pulse frequency		600 MHz	
Speed of computation		4800 MIPS	
Digital resolution		32 Bit	
Functional safety related parameters			
MTTF _d		94 a	
Mission Time (T _M)		10 a	
Diagnostic Coverage (DC)		0 %	
Indicators/operating means			
LED indication		7 LEDs (communication, alignment aid, status information)	
Electrical specifications			
Operating voltage	U _B	15 ... 30 V DC , PELV	
No-load supply current	I ₀	max. 200 mA	
Power consumption	P ₀	3 W	
Interface			
Interface type		RS-485 - Interface	
Data output code		binary code	
Transfer rate		38400 ... 230400 Bit/s	
Termination		Switchable terminal resistor	
Query cycle time		≥ 10 ms	
Input			
Input type		1 to 3 functional inputs , programmable	
Input impedance		≥ 27 kΩ	
Output			
Output type		1 to 3 switch outputs , PNP , programmable , short-circuit protected	
Switching voltage		Operating voltage	
Switching current		150 mA each output	
Standard conformity			
Emitted interference		EN 61000-6-4:2007+A1:2011	
Noise immunity		EN 61000-6-2:2005	
Shock resistance		EN 60068-2-27:2009	
Vibration resistance		EN 60068-2-6:2008	
Approvals and certificates			
CCC approval		CCC approval / marking not required for products rated ≤36 V	
Ambient conditions			
Operating temperature		0 ... 60 °C (32 ... 140 °F) , -20 ... 60 °C (-4 ... 140 °F) (noncondensing; prevent icing on the lens!)	
Storage temperature		-20 ... 85 °C (-4 ... 185 °F)	
Relative humidity		90 % , noncondensing	
Mechanical specifications			
Connection type		8-pin, M12 x 1 connector	
Degree of protection		IP67	
Material			
Housing		PC/ABS	
Mass		approx. 160 g	
Dimensions			
Height		70 mm	
Width		70 mm	
Depth		50 mm	
Factory settings			

Release date: 2024-02-07 Date of issue: 2024-02-07 Filename: 242706_eng.pdf

Refer to "General Notes Relating to Pepperl+Fuchs Product Information".

Pepperl+Fuchs Group
www.pepperl-fuchs.comUSA: +1 330 486 0001
fa-info@us.pepperl-fuchs.comGermany: +49 621 776 1111
fa-info@de.pepperl-fuchs.comSingapore: +65 6779 9091
fa-info@sg.pepperl-fuchs.com

PEPPERL+FUCHS

Technical Data

X resolution (protocol)	1 mm
Y resolution (protocol)	1 mm
Code tape orientation	0 °
Address	0
Baud rate	115200 Bd
Bus termination	ON
"No Position" X value	0
"No Position" Y value	0
"No Position" speed value	127
Overspeed threshold (protocol)	12.5 m/s
X value in case of error	Error number
Y value in case of error	Error number
Speed value in case of error	Error number
Code tape width	two-rowed
X position offset	0 mm
Function input/output	inactive

Connection

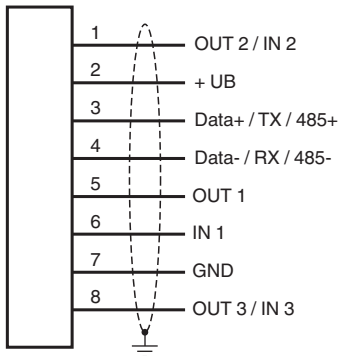

Connection Assignment

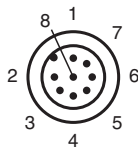

Release date: 2024-02-07 Date of issue: 2024-02-07 Filename: 242706_eng.pdf

Refer to "General Notes Relating to Pepperl+Fuchs Product Information".

Pepperl+Fuchs Group
www.pepperl-fuchs.com

USA: +1 330 486 0001
fa-info@us.pepperl-fuchs.com

Germany: +49 621 776 1111
fa-info@de.pepperl-fuchs.com

Singapore: +65 6779 9091
fa-info@sg.pepperl-fuchs.com

Characteristic Curve

Coordinates

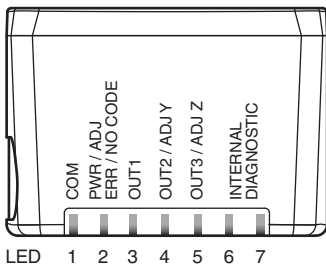
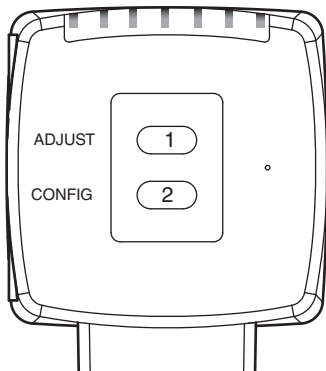
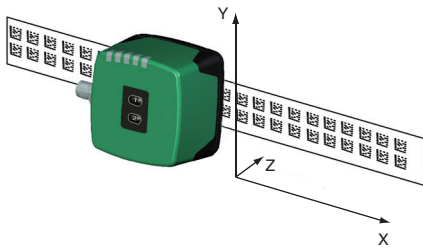

Release date: 2024-02-07 Date of issue: 2024-02-07 Filename: 242706_eng.pdf

Refer to "General Notes Relating to Pepperl+Fuchs Product Information".

Pepperl+Fuchs Group
www.pepperl-fuchs.com

USA: +1 330 486 0001
fa-info@us.pepperl-fuchs.com

Germany: +49 621 776 1111
fa-info@de.pepperl-fuchs.com

Singapore: +65 6779 9091
fa-info@sg.pepperl-fuchs.com

Additional Information

General

The reading head is part of the positioning system in the method for measurement by Pepperl+Fuchs. It consists of a camera module and an integrated illumination unit among other things. The reading head detects position marks, which are put on an adhesive code band in the form of Data Matrix code. The mounting of the code band is as a rule stationary on a firm part of the plant (elevator shaft, overhead conveyor mounting rails...); that of the reading head is parallel on the moving "vehicle" (elevator car, overhead conveyor chassis...).

Mounting and commissioning

Mount the reading head such that its optical surface captures the optimal read distance to the code band (see Technical Data). The stability of the mounting and the guidance of the vehicle must be provided such that the depth of field of the reading head is not closed during operation. All reading heads can be optimally customized by parameterization for specific requirements. The parameterization of reading heads with a bi-directional interface (all except SSI-interface) can take place via the interface itself (internal parameterization) or via an optical parameterization code (external parameterization). The reading heads with SSI interface only have the possibility of external parameterization via optical parameterization codes.

Displays and Controls

The reading head allows visual function check and fast diagnosis with 7 indicator LEDs. The reading head has 2 buttons on the reverse of the device to activate the alignment aid and parameterization mode.

LEDs

LED	Color	Label	Meaning
1	Yellow	COM	Communication active
2	Green/red	PWR/ADJ ERR/NO CODE	Code recognized/not recognized, Error
3	Yellow	OUT1	Output 1
4	Yellow	OUT2/ADJ Y	Output 2, Alignment aid Y
5	Yellow	OUT3/ADJ Z	Output 3, Alignment aid Z
6,7	red/green/yellow	INTERNAL DIAGNOSTICS	Internal diagnostics

External parameterization

For external parameterization you require the parameterization code as Data Matrix with the desired reading head parameters. Data Matrix code cards for step-by-step external parameterization are printed in the reading heads operating instructions.

Parameterization is only possible within 10 minutes of switching on the reading head. If a button is pressed after 10 minutes subsequent to switching on, there is visual signaling via the LEDs (LED1, yellow/LED2, red/LED3, yellow/LED4, yellow/LED5, yellow flash for 2 seconds)

- The switchover from normal operation to parameterization mode is via button 2 on the reverse of the reading head. Button 2 must be pressed for more than 2 seconds. LED3 now flashes.

Note: Parameterization mode automatically ends after 1 minute of inactivity. The reading head returns to normal operation and works with unchanged settings.

- Place the parameterization code in the view of the camera module. After recognition of the parameterization code, the green LED2 lights up for 1s. In the event of an invalid parameterization code, the red LED2 lights up for 2 s.
- A short press on button 2 ends the parameterization mode and the changed parameters are not stored volatile in the reading head.

Alignment aid for the Y and Z coordinates

The activation of the alignment aid is only possible within 10 minutes of switching on the reading head. The switchover from normal operation to "alignment aid operating mode is via button 1 on the reverse of the reading head.

- Press the button 1 for longer than 2 s. LED2 flashes green for a recognized code band. LED2 flashes red for an unrecognized code band.
- Z coordinate:** If the distance of the camera to the code band too small, the yellow LED5 lights up. If the distance of the camera to the code band too large, the yellow LED5 lights up. Within the target range, the yellow LED5 flashes at the same time as the green LED2.
- Y coordinate:** If the optical axis of the camera is too deep in relation to the middle of the code band, the yellow LED4 lights up. If the optical axis is too high, the yellow LED4 extinguishes. Within the target range, the yellow LED4 flashes at the same time as the green LED2.
- A short press on button 1 ends the alignment aid and the reading head changes to normal operation.