



Vision Sensor

PHA200-F200A-B17-T-V1D



- Detects the position of an index hole
- Large capture range
- High operating range
- Integrated contrast compensation
- Compact design
- PROFINET interface
- Integrated illumination
- Extended temperature range

Precision positioning on hole in the 70 mm x 70 mm housing



Function

The sensor has been developed for the precision positioning of high-bay racking operating equipment. It detects circular holes in the racking structure and their positional deviation from the nominal position. The sensor operates in two dimensions.

Dimensions

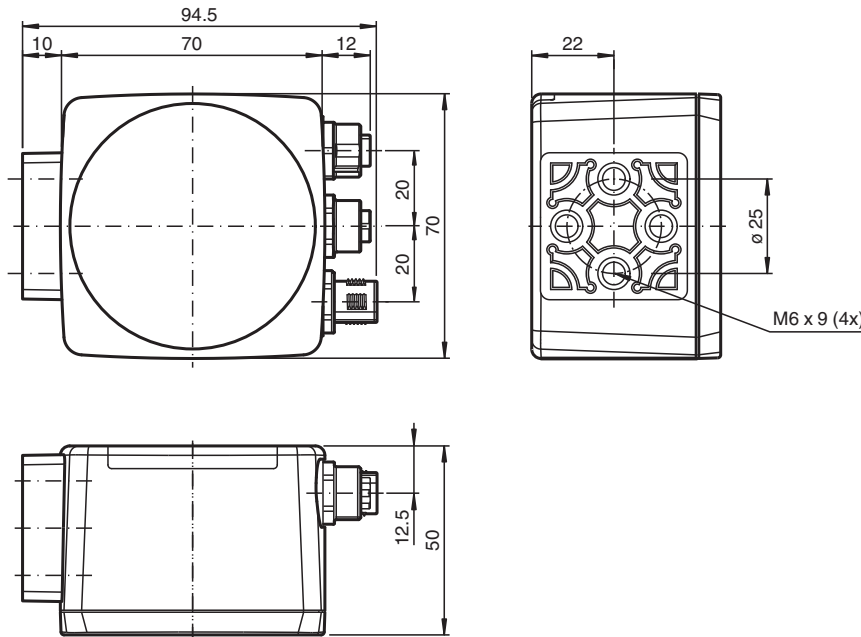

Release date: 2024-02-07 Date of issue: 2024-02-07 Filename: 295668_eng.pdf

Technical Data

General specifications

| | |
|----------------|-------------------------------------|
| Light type | Integrated LED lightning (infrared) |
| Object size | Hole diameter 13 mm |
| Response delay | 100 ms |
| Read distance | 200 mm |
| Depth of focus | ± 50 mm |

Refer to "General Notes Relating to Pepperl+Fuchs Product Information".

Pepperl+Fuchs Group
www.pepperl-fuchs.com

USA: +1 330 486 0001
fa-info@us.pepperl-fuchs.com

Germany: +49 621 776 1111
fa-info@de.pepperl-fuchs.com

Singapore: +65 6779 9091
fa-info@sg.pepperl-fuchs.com

PF PEPPERL+FUCHS

Technical Data

| | | |
|---|----------------|--|
| Capture range | | max. 120 mm x 100 mm |
| Nominal ratings | | |
| Camera | | |
| Type | | CMOS , Global shutter |
| Number of pixels | | 752 x 480 pixels |
| Gray scale | | 256 |
| Functional safety related parameters | | |
| MTTF _d | | 95 a |
| Mission Time (T _M) | | 10 a |
| Diagnostic Coverage (DC) | | 0 % |
| Indicators/operating means | | |
| Operation indicator | | LED green: Ready for operation |
| Function indicator | | 7 LEDs (communication, alignment aid, status information) |
| Control elements | | Button for parameterization |
| Electrical specifications | | |
| Operating voltage | U _B | 24 V DC +/- 15 %, PELV |
| No-load supply current | I ₀ | max. 400 mA |
| Power consumption | P ₀ | 6 W |
| Interface | | |
| Interface type | | 100 BASE-TX PROFINET |
| Protocol | | PROFINET IO Real-Time (RT) Conformance class A |
| Transfer rate | | 100 MBit/s |
| Interface 2 | | |
| Interface type | | USB (serial comport) |
| Transfer rate | | ... 12000 kBit/s |
| Conformity | | |
| Shock resistance | | EN 60068-2-27:2009 |
| Vibration resistance | | EN 60068-2-6:2008 |
| Emitted interference | | EN 61000-6-4:2007+A1:2011 |
| Noise immunity | | EN 61000-6-2:2005 |
| Photobiological safety | | exempt group according to EN 62471:2008 |
| Approvals and certificates | | |
| CE conformity | | CE |
| CCC approval | | CCC approval / marking not required for products rated ≤36 V |
| Ambient conditions | | |
| Operating temperature | | -30 ... 60 °C (-22 ... 140 °F) , (noncondensing; prevent icing on the lens!) |
| Storage temperature | | -30 ... 85 °C (-22 ... 185 °F) |
| Relative humidity | | 90 % , noncondensing |
| Mechanical specifications | | |
| Degree of protection | | IP67 |
| Material | | |
| Housing | | PC/ABS |
| Optical face | | Plastic pane |
| Installation | | 4 x M6 threading |
| Mass | | approx. 200 g |
| Dimensions | | |
| Height | | 70 mm |
| Width | | 70 mm |
| Depth | | 50 mm |

Release date: 2024-02-07 Date of issue: 2024-02-07 Filename: 295658_eng.pdf

Refer to "General Notes Relating to Pepperl+Fuchs Product Information".

Pepperl+Fuchs Group
www.pepperl-fuchs.comUSA: +1 330 486 0001
fa-info@us.pepperl-fuchs.comGermany: +49 621 776 1111
fa-info@de.pepperl-fuchs.comSingapore: +65 6779 9091
fa-info@sg.pepperl-fuchs.com

PEPPERL+FUCHS

Connection



Connection Assignment



Indication



Release date: 2024-02-07 Date of issue: 2024-02-07 Filename: 295658_eng.pdf

Refer to "General Notes Relating to Pepperl+Fuchs Product Information".

Characteristic Curve

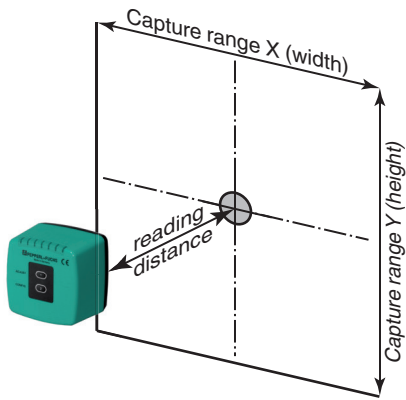

Release date: 2024-02-07 Date of issue: 2024-02-07 Filename: 295658_eng.pdf

Refer to "General Notes Relating to Pepperl+Fuchs Product Information".

Pepperl+Fuchs Group
www.pepperl-fuchs.com

USA: +1 330 486 0001
fa-info@us.pepperl-fuchs.com

Germany: +49 621 776 1111
fa-info@de.pepperl-fuchs.com

Singapore: +65 6779 9091
fa-info@sg.pepperl-fuchs.com

 **PEPPERL+FUCHS**

Additional Information

General

The PHA... Vision Sensor has been developed for the rack fine positioning of stock feeders. This device detects circular holes in the rack structure and determines the position deviation of these holes in relation to the target position. The Vision Sensor operates in two dimensions.

Mounting and Commissioning

Mount the PHA... Vision Sensor in such a way that the optical surface of the device captures the optimum distance to the carrier/hole (see "Technical Data"). The stability of the Vision Sensor mounting and the manner in which the vehicle is guided must ensure that the device is not operated outside of its depth of focus range.

All Vision Sensors can be adapted to optimally meet specific requirements by means of parameterization.

Indicators and Controls

The PHA... Vision Sensor is equipped with seven indicator LEDs for carrying out visual function checks and rapid diagnostics. The read head is equipped with two buttons at the back for activating the parameterization mode.

LEDs

| LED | Color | Labeling | Meaning |
|-----|------------------|---------------------|---------------------------------------|
| 1 | yellow | BUS LINK | PROFINET communication active |
| 2 | yellow | BUS TX / RX | Data transfer |
| 3 | red | BUS ERR | PROFINET communication error |
| 4 | green/red | PWR/ERR | Fault with power supply/general error |
| 5 | yellow | ZERO POS | Zero position reached |
| 6 | yellow | RANGE | Within detection/capture range |
| 7 | red/green/yellow | INTERNAL DIAGNOSTIC | Internal diagnostics |

External Parameterization

In order to parameterize the device externally, the parameterization code is required in the form of a data matrix containing the desired parameters. Data matrix code cards detailing the step-by-step process for externally parameterizing the device are printed in the operating instructions for the Vision Sensor.

- The Vision Sensor is switched over from normal operation to parameterization mode using button 2 on the back of the device. To switch the device over, button 2 must be pressed and held for more than two seconds. LED5 then flashes.
Note: Parameterization mode is exited automatically if the device is inactive for one minute. In this case, the Vision Sensor reverts to normal mode and operates without the settings having been changed.
- Place the parameterization code in the field of vision of the camera module. After the parameterization code is detected, the green LED4 lights up for one second. In the event of an invalid parameterization code, LED4 lights up red for two seconds.
- Briefly pressing button 2 will end parameterization mode. Unsaved changes will be lost.

Release date: 2024-02-07 Date of issue: 2024-02-07 Filename: 295658_eng.pdf