

## Mounting bracket MBT-36ALS

Spring-loaded mounting bracket with a diameter of 36 mm

### Function

The extremely high-quality, spring-loaded mounting bracket is perfectly suited for mounting rotary encoders in combination with a measuring wheel with a circumference of 500 mm. The 12 mounting holes on a pitch circle of 48 mm and offset by 30° in each case enable the optimal alignment of the rotary encoder. The carefully tuned suspension guarantees permanent contact pressure between the measuring wheel and the object. Measuring wheels in various diameters and with different coatings are available as accessories for our rotary encoders.

### Dimensions

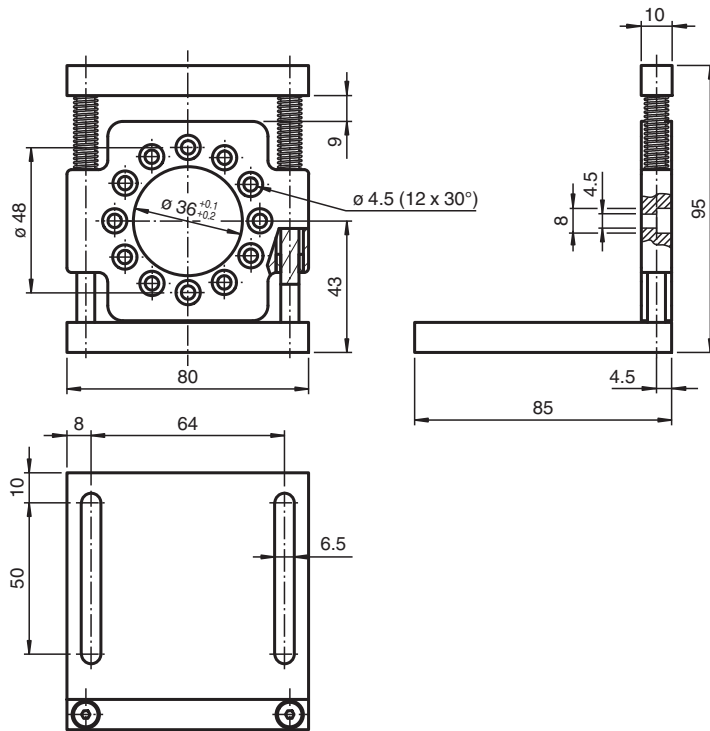

### Technical Data

#### Ambient conditions

Ambient temperature -40 ... 120 °C (-40 ... 248 °F)

#### Mechanical specifications

Material anodized aluminum

Mass 320 g

Release date: 2022-12-12 Date of issue: 2022-12-12 Filename: 319071\_eng.pdf

Refer to "General Notes Relating to Pepperl+Fuchs Product Information".

Pepperl+Fuchs Group  
www.pepperl-fuchs.com

USA: +1 330 486 0001  
fa-info@us.pepperl-fuchs.com

Germany: +49 621 776 1111  
fa-info@de.pepperl-fuchs.com

Singapore: +65 6779 9091  
fa-info@sg.pepperl-fuchs.com

**PF** PEPPERL+FUCHS