



# Inertial measurement unit

## IMUF99PL-SC3600-0KB20V1501

- Dynamic inclination measurement despite external acceleration
- Adjustable ranges for compensation of external accelerations, disturbances
- Adjustable thresholds for detection of measured value overruns
- Measurement of inclination, acceleration and rotation rate in 3 axis each
- CAN bus with SAE J1939 protocol

Inertial measurement unit for inclination, acceleration and rotation rate measurement in 3-axis each



### Function

The IMUF99 is optimized to provide stabilized inclination and acceleration data as well as rotation rate data. The horizontal inclination can be reliably determined using the 3 measuring axis. The dynamic angle accuracy can be individually configured by selecting a compensation range to counteract the influence of external accelerations. Different output types are selectable for the angle definition (Euler angle, Euler vector, quaternions). In addition, accelerations and rotation rates are reliably measured in the 3 measuring axis. For further optimization of the measured value quality, filters can be set to suppress external vibrations.

### Dimensions

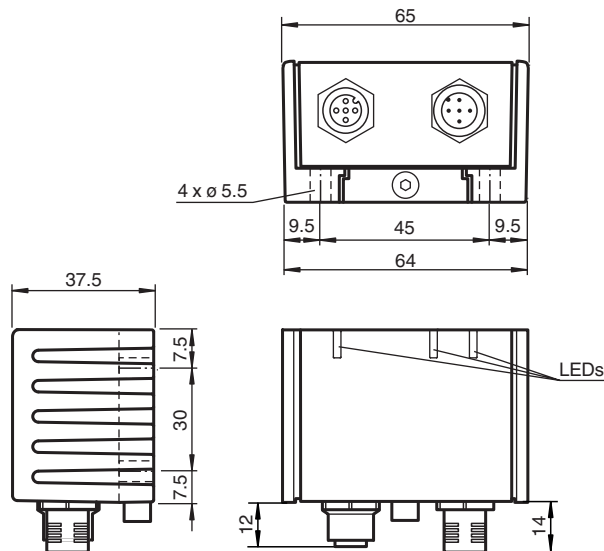

### Technical Data

#### General specifications

Type	Inertial measurement unit 3-axis
Measuring technology	MEMS

#### Inclination measurement

Release date: 2023-05-02 Date of issue: 2023-05-02 Filename: 70130406\_eng.pdf

Refer to "General Notes Relating to Pepperl+Fuchs Product Information".

Pepperl+Fuchs Group  
www.pepperl-fuchs.com

USA: +1 330 486 0001  
fa-info@us.pepperl-fuchs.com

Germany: +49 621 776 1111  
fa-info@de.pepperl-fuchs.com

Singapore: +65 6779 9091  
fa-info@sg.pepperl-fuchs.com

**PF** PEPPERL+FUCHS

## Technical Data

Measurement range		0 ... 360 °
Static accuracy		± 0.15 ° at 25 °C for inclination range ±45 ° ± 0.2 ° at 25 °C for inclination range ±90 ° ± 0.3 ° at 25 °C for inclination range 360 °
Dynamic accuracy		< 0.5 ° absolute, absolut, bei 25 °C über 360 ° Neigungsbereich
Resolution		0.01 °
Repeat accuracy		± 0.1 °
Temperature influence		± 0.015 ° / K
<b>Acceleration measurement</b>		
Measurement range		± 4 g
Linearity		± 0,5% of the measured value, up to ±1 g for -40 ... +85 °C
Resolution		0.001 g
Frequency range		0 ... 30 Hz
<b>Rotation rate measurement</b>		
Measurement range		± 250 °/s
Accuracy		± 0.2 °/s at 25 °C in the measuring range ±45 °/s ± 0.5 °/s at 25 °C in the measuring range ±120 °/s ± 1 °/s at 25 °C in the measuring range ±250 °/s
Resolution		0.01 °/s
<b>Functional safety related parameters</b>		
MTTF <sub>d</sub>		628 a
Mission Time (T <sub>M</sub> )		10 a
Diagnostic Coverage (DC)		0 %
<b>Indicators/operating means</b>		
Operation indicator		LED, green
Status indicator		LED, yellow
Error indicator		LED, red
<b>Electrical specifications</b>		
Operating voltage	U <sub>B</sub>	5 ... 30 V DC
No-load supply current	I <sub>0</sub>	≤ 80 mA
Power consumption	P <sub>0</sub>	≤ 0.6 W
<b>Interface</b>		
Interface type		CAN bus with SAE J1939 protocol
Node ID		0 ... 253 , programmable
Transfer rate		10 ... 1000 kBit/s , programmable
Termination		external
Cycle time		10 ... 655350 ms , programmable
<b>Standard conformity</b>		
Climatic testing		EN IEC 60068-2-38 , cyclic 12h + 12h, 94% humidity EN 60068-2-14 , test Na, -50 ... +85 °C, 10 cycles
Salt spray test		IEC 60068-2-52 , cyclic
Emitted interference		EN IEC 61000-6-4:2019 , EN 55011:2016+A1:2017+A11:2020
Noise immunity		EN IEC 61000-6-2:2019 , ISO 7637-2:2011 , ISO 7637-3:2016 , ISO 16750-2:2012
Shock resistance		EN 60068-2-27, 100 g, 6 ms
Vibration resistance		EN 60068-2-6, 20 g, 10 ... 2000 Hz
<b>Approvals and certificates</b>		
UL approval		E87056 , cULus Listed, General Purpose, Class 2 Power Source, Type 1 enclosure , if UL marking is marked on the product. For use in NFPA 79 Applications only. adapters providing field wiring on request
E1 Type approval		10R-06
<b>Ambient conditions</b>		
Ambient temperature		-40 ... 85 °C (-40 ... 185 °F)
Storage temperature		-40 ... 85 °C (-40 ... 185 °F)
<b>Mechanical specifications</b>		

Release date: 2023-05-02 Date of issue: 2023-05-02 Filename: 70130406\_eng.pdf

## Technical Data

Connection type	5-pin, M12 x 1 connector 5-pin, M12 x 1 socket internal bridged
Housing material	PA
Degree of protection	IP68 / IP69
Mass	265 g
<b>Factory settings</b>	
Node ID	128
Transfer rate	250 kBit/s
Cycle time	10 ms
Compensation range	4

## Connection

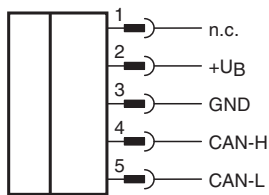

## Connection Assignment

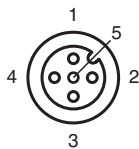
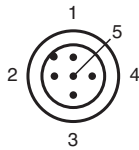

Release date: 2023-05-02 Date of issue: 2023-05-02 Filename: 70130406\_eng.pdf

**Operation**

Spatially fixed coordinate system (extrinsic reference to the horizontal plane) for P+F angles INX or INY

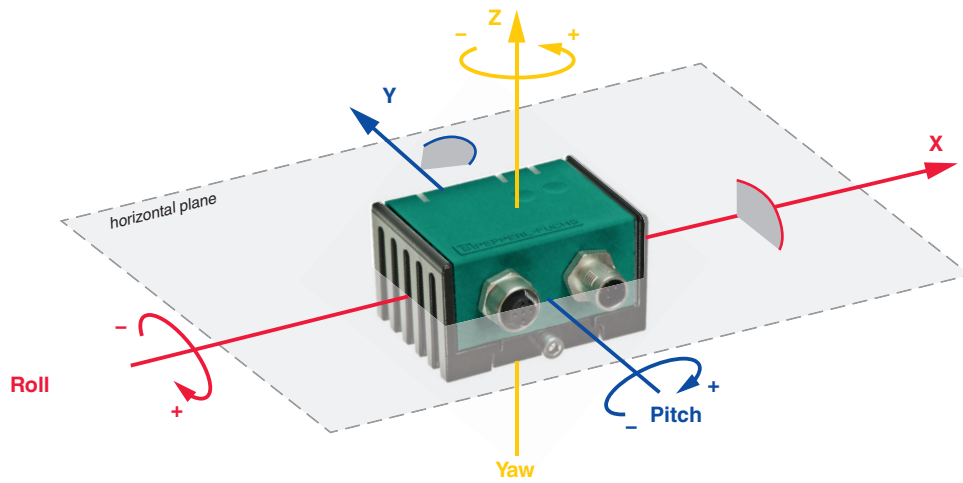

Spatially fixed coordinate system (extrinsic reference to the horizontal plane) for Euler angle ZXZ

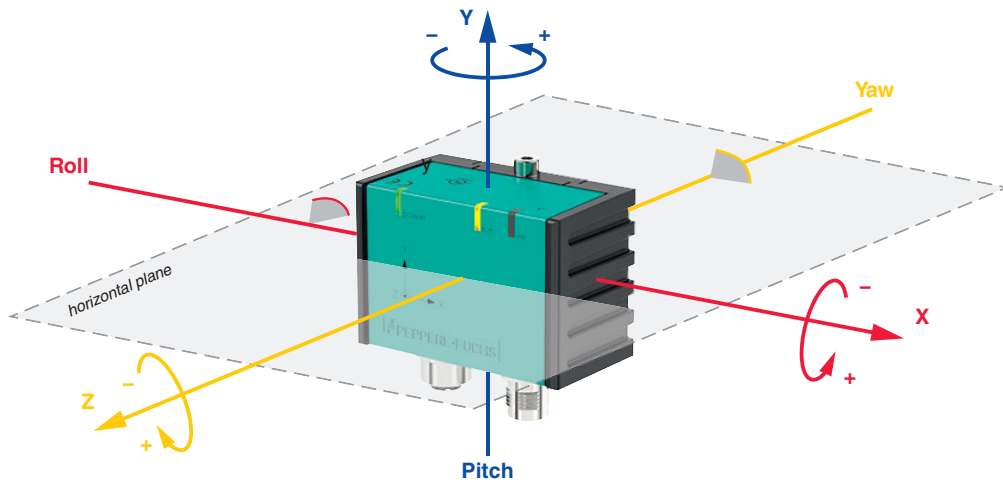

Body fixed coordinate system (intrinsic or co-rotating) for Euler angle zy'x''

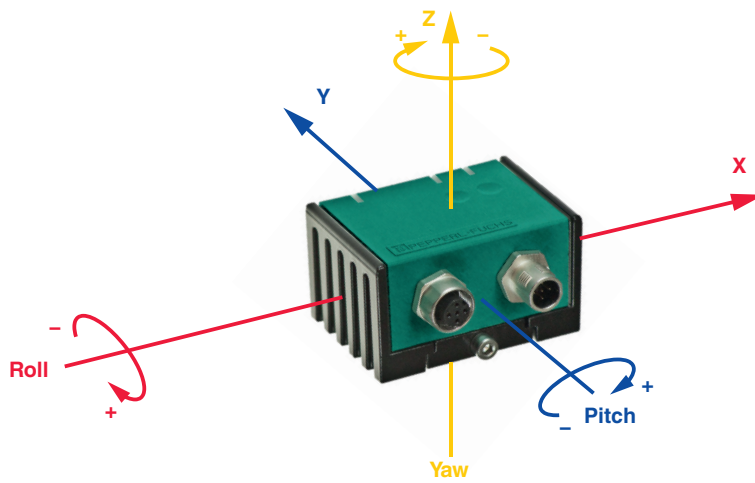

Release date: 2023-05-02 Date of issue: 2023-05-02 Filename: 70130406\_eng.pdf







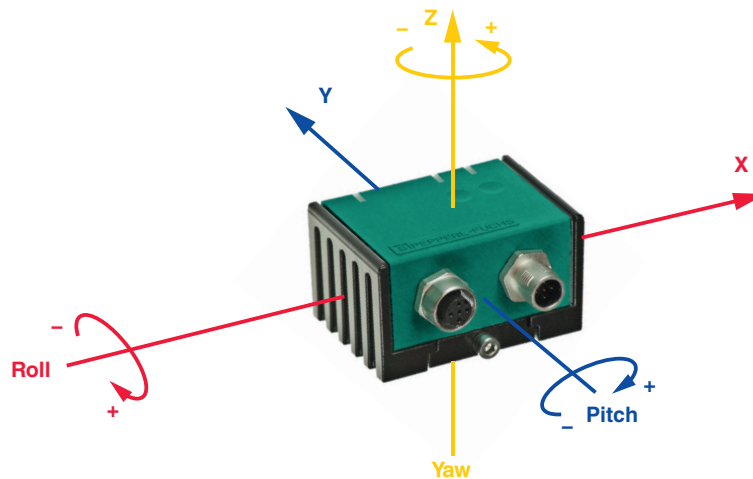



Refer to "General Notes Relating to Pepperl+Fuchs Product Information".

**Operation**

Body fixed coordinate system (intrinsic or co-rotating) for P+F angle INZ



**Accessories**

	<b>V15S-TR-CAN/DN-120R</b>	Terminal resistor for DeviceNet, CANopen
	<b>V15-G-VT0,5M-PUR-U/CAN-V15-G</b>	DeviceNet/CANOpen bus cable M12 socket straight to M12 plug straight A-coded, 5-pin, PUR cable violet, shielded, UL approved, drag chain suitable, salt water resistant
	<b>V15-G-VT1M-PUR-U/CAN-V15-G</b>	DeviceNet/CANOpen bus cable M12 socket straight to M12 plug straight A-coded, 5-pin, PUR cable violet, shielded, UL approved, drag chain suitable, salt water resistant
	<b>V15-G-VT10M-PUR-U/CAN-V15-G</b>	DeviceNet/CANOpen bus cable M12 socket straight to M12 plug straight A-coded, 5-pin, PUR cable violet, shielded, UL approved, drag chain suitable, salt water resistant
	<b>V15-G-VT5M-PUR-U/CAN-V15-G</b>	DeviceNet/CANOpen bus cable M12 socket straight to M12 plug straight A-coded, 5-pin, PUR cable violet, shielded, UL approved, drag chain suitable, salt water resistant
	<b>V15-G-VT6M-PUR-U/CAN-V15-G</b>	DeviceNet/CANOpen bus cable M12 socket straight to M12 plug straight A-coded, 5-pin, PUR cable violet, shielded, UL approved, drag chain suitable, salt water resistant
	<b>V15-G-BK0,3M-PUR-O2/CAN-V15-G</b>	DeviceNet/CANOpen bus cable M12 socket straight to M12 plug straight A-coded, 5-pin, PUR cable 4-core twisted pairs black, shielded, UL approved, drag chain suitable, outdoor
	<b>V15-G-BK1M-PUR-O2/CAN-V15-G</b>	DeviceNet/CANOpen bus cable M12 socket straight to M12 plug straight A-coded, 5-pin, PUR cable 4-core twisted pairs black, shielded, UL approved, drag chain suitable, outdoor
	<b>V15-G-BK10M-PUR-O2/CAN-V15-G</b>	DeviceNet/CANOpen bus cable M12 socket straight to M12 plug straight A-coded, 5-pin, PUR cable 4-core twisted pairs black, shielded, UL approved, drag chain suitable, outdoor
	<b>V15-G-BK3M-PUR-O2/CAN-V15-G</b>	DeviceNet/CANOpen bus cable M12 socket straight to M12 plug straight A-coded, 5-pin, PUR cable 4-core twisted pairs black, shielded, UL approved, drag chain suitable, outdoor
	<b>CAN/USB-Configuration-Kit</b>	CAN/USB configuration kit containing CAN/USB converter, power supply and adapter/connection cables

Release date: 2023-05-02 Date of issue: 2023-05-02 Filename: 70130406\_eng.pdf

## Mounting

### Mounting of the sensor

Sensors from the -F99 series consist of a sensor module and accompanying cast aluminum housing. Select a flat surface with minimum dimensions of 70 mm x 50 mm to mount the sensor.

Mount the sensor as follows:

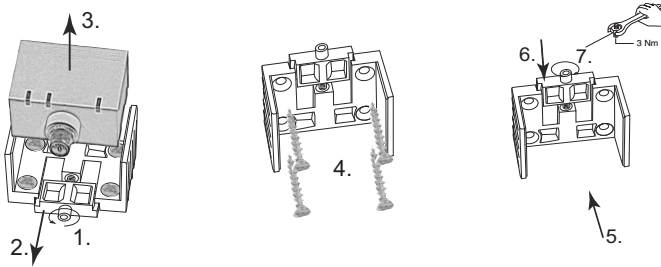

1. Loosen the central screw under the sensor connection.
  2. Slide back the clamping element until you are able to remove the sensor module from the housing.
  3. Remove the sensor module from the housing
  4. Position the housing at the required mounting location and secure using four countersunk screws. Make sure that the heads of the screws do not protrude.
  5. Place the sensor module in the housing.
  6. Slide the clamping element flush into the housing. Check that the sensor element is seated correctly.
  7. Finally tighten the central screw.
- The sensor is now mounted correctly.