



Vision Sensor

VOS1000C-F226W-8MM-S

- Color sensor
- Wide range of detection tools for flexible inspection tasks
- Combinable vision tools for feature detection, completeness checking, code reading, text recognition and object position checking
- 32 Jobs on-board can be saved
- Integrated illumination
- Mechanical focus adjustment
- Easy integration with flexible programmable data output

Vision sensor for advanced object detection; Resolution: 640 x 480 pixels; Light source: integrated LED flash, white; Lens: M12 lens; Focal length: 8 mm



Dimensions

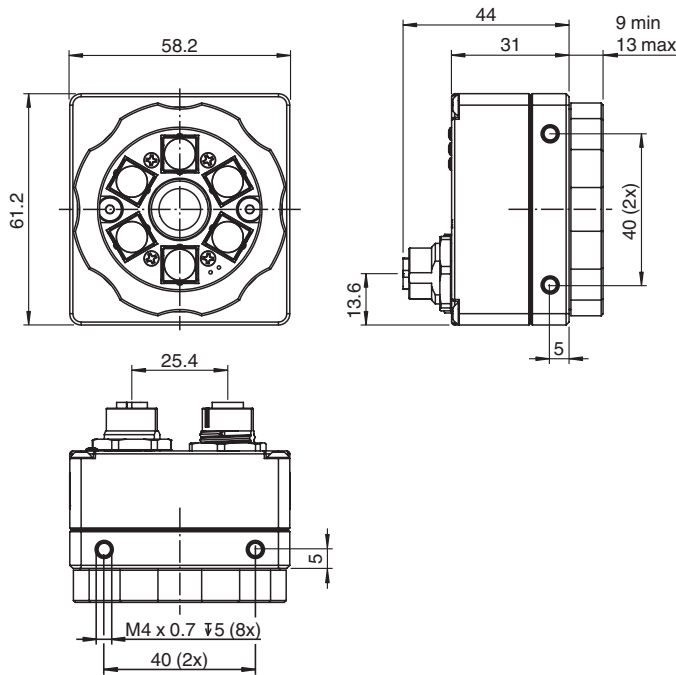

Technical Data

General specifications

Light source	Integrated LED lightning , white
Picture detail	dependant of operating distance (see manual)
Trigger mode	Free-running or triggered externally
Depth of focus	\pm 5 % of the operating distance
Focal length	8 mm
Resolution	640 x 480 pixels
Image sensor	1/3" CMOS color Global Shutter 3.75 μ m pixel size

Release date: 2024-03-12 Date of issue: 2024-03-12 Filename: 70131270_eng.pdf

Refer to "General Notes Relating to Pepperl+Fuchs Product Information".

Pepperl+Fuchs Group
www.pepperl-fuchs.com

USA: +1 330 486 0001
fa-info@us.pepperl-fuchs.com

Germany: +49 621 776 1111
fa-info@de.pepperl-fuchs.com

Singapore: +65 6779 9091
fa-info@sg.pepperl-fuchs.com

PEPPERL+FUCHS

Technical Data

Lens		M12 integrated lens
Parameterization/software		
Parameter assignment		Parameterization via PC user interface VCT Tool
Evaluation procedure		
Positioning and Guidance		Based on Parts or product marks, up to four Locators to detect X,Y shift and rotation
Identification and Verification		OCR, 1-D and 2-D codes
Detection & Pattern Matching		Pixel-, contour- or edge count
Measuring		Distance, angle, circle size (after calibration)
Indicators/operating means		
LED 1		Steady blue: sensor started, not set up Steady green: job loaded, ready for execution Flashing green: job loaded and being executed, capture in progress Steady red: sensor fault
LED 2		Flashing blue: starting (duration approx. 20 seconds) Steady green: measurement successful (Pass) Steady blue: measurement borderline (Recycle) Steady red: measurement unsuccessful (Fail)
LED 3		Steady blue: warm reset or restart Steady red/green/yellow: network activity
Focus setting		Focus adjustable via centering
Electrical specifications		
Operating voltage	U_B	12 ... 30 V DC
No-load supply current	I_0	300 mA
Interface 1		
Interface type		Ethernet
Protocol		PROFINET IO TCP/IP EtherNet/IP
Transfer rate		100 MBit/s
Interface 2		
Interface type		RS-232 , serial
Transfer rate		115.2 kBit/s
Input		
Input type		optically decoupled Inputs
Input voltage		Logic low (OFF): 0 ... 3 V Logic high (ON): 11 ... 30 V Switching threshold: 12 V
Control input		Image capture trigger + 2 general purpose inputs 2 inputs can be used for job switching
Input current		8 mA (typical)
Internal protection circuit		3 k Ω / 4000 V (rms)
Switching delay		Switch-on time (ON): 20 μ s Switch-off time (OFF): 10 μ s Image capture trigger: 62 μ s (until image capture is triggered)
Output		
Output type		3 general purpose outputs , freely programmable , optically decoupled
Switching voltage		max. 30 V
Switching current		max. 100 mA each output
Switching delay		Switch-on time (ON): 150 μ s Switch-off time (OFF): 50 μ s
Standard conformity		
Emitted interference		EN 61000-6-4:2007+A1:2011
Noise immunity		EN 61000-6-2:2005
Approvals and certificates		
Approvals		CE
Ambient conditions		
Ambient temperature		0 ... 50 °C (32 ... 122 °F)
Storage temperature		-20 ... 60 °C (-4 ... 140 °F)
Mechanical specifications		

Release date: 2024-03-12 Date of issue: 2024-03-12 Filename: 70131270_eng.pdf

Refer to "General Notes Relating to Pepperl+Fuchs Product Information".

Pepperl+Fuchs Group
www.pepperl-fuchs.comUSA: +1 330 486 0001
fa-info@us.pepperl-fuchs.comGermany: +49 621 776 1111
fa-info@de.pepperl-fuchs.comSingapore: +65 6779 9091
fa-info@sg.pepperl-fuchs.com

PEPPERL+FUCHS

Technical Data

Degree of protection	IP67
Connection	8-pin M12 socket A-coded ; 12-pin M12 socket
Material	
Housing	anodized aluminum
Optical face	Plastic pane
Installation	Mounting bracket
Mass	approx. 200 g
Dimensions	
Height	57 mm
Width	58 mm
Length	61 mm

Connection Assignment

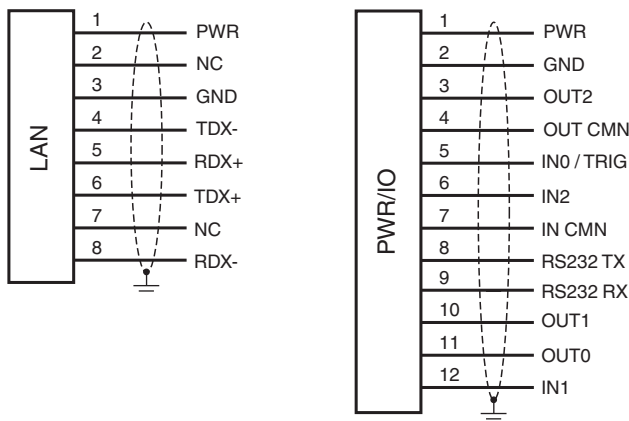

Connection

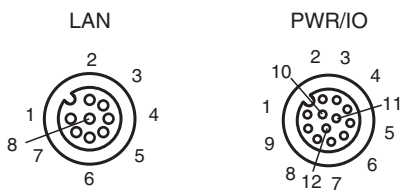

Release date: 2024-03-12 Date of issue: 2024-03-12 Filename: 70131270_eng.pdf