

Features

- 1-channel isolated barrier
- 24 V DC supply (Power Rail)
- Resistance and RTD input (Pt100, Pt500, Pt1000)
- Resistance output
- Accuracy 0.1 %
- Line fault detection (LFD) for Pt100
- Connection via spring terminals with push-in connection technology
- Housing width 12.5 mm

Function

This isolated barrier is used for intrinsic safety applications. It transfers resistance values of RTDs or potentiometers from hazardous areas to safe areas. A 2-, 3-, or 4-wire technique is available depending on the required accuracy. The input card of the control system measures the same load as if it were connected directly to the resistance in a hazardous area.

Assembly

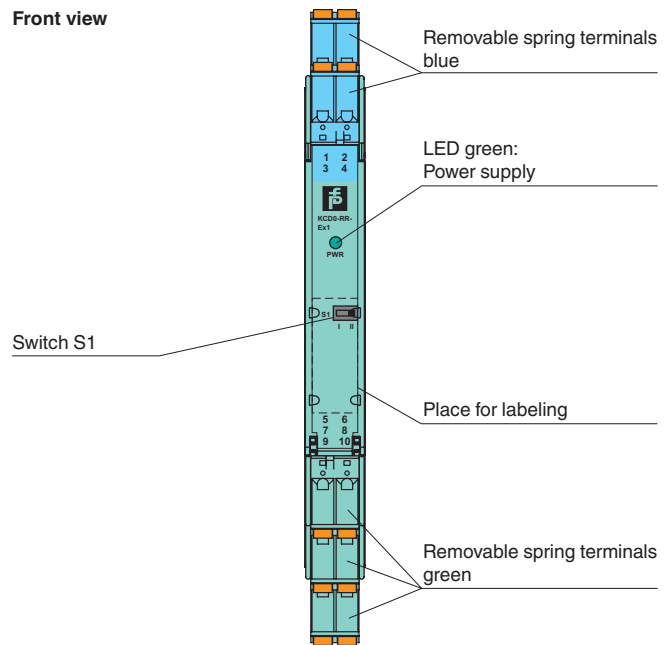

Connection

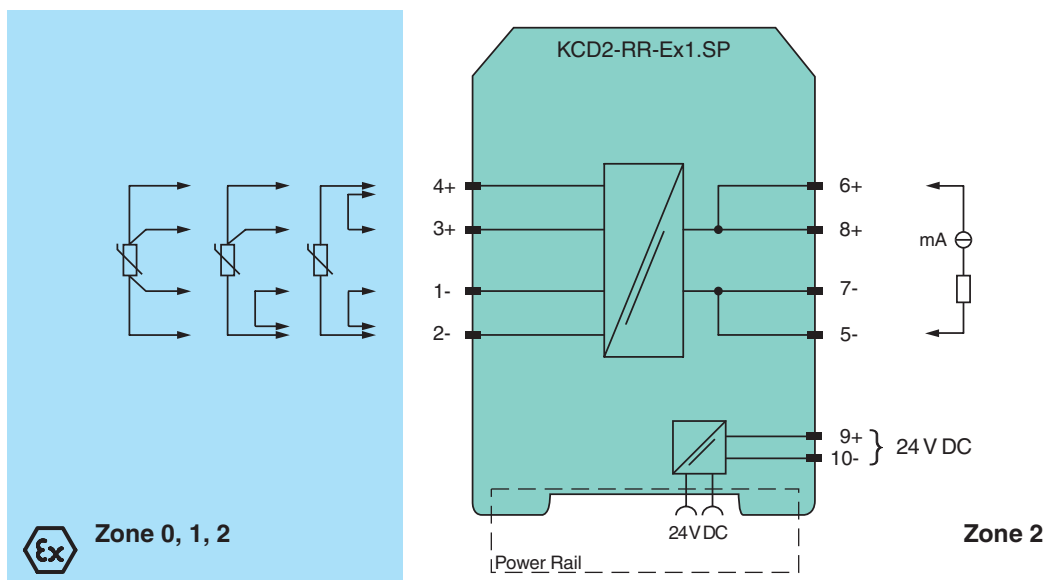

Release date 2019-08-20 09:18 Date of issue 2019-08-20 240635_eng.xml

Refer to "General Notes Relating to Pepperl+Fuchs Product Information".

General specifications		
Signal type		Analog input
Supply		
Connection		Power Rail or terminals 9+, 10-
Rated voltage	U_r	19 ... 30 V DC
Ripple		within the supply tolerance
Rated current	I_r	< 20 mA
Power consumption		0.35 W (24 V and 1 mA sense current)
Input		
Connection		terminals 1, 2, 3, 4
Line fault detection		yes, at Pt100
Lead resistance		≤ 10 % of resistance value
Transmission range		0 ... 10 mA
Available voltage		9 V
Line fault detection		50 nA
Output		
Connection		terminals 5-, 7-, 6+, 8+
Current		0 ... 10 mA
Available voltage		0 ... 7 V
Fault signal		< 10 Ω or > 400 Ω, depending on lead disconnected (measuring current ≤ 1 mA)
Transfer characteristics		
Deviation		$I_m \geq 1 \text{ mA}$: ±0.1 % of R_m or ± 0.1 Ω (the larger value is applicable) $I_m < 1 \text{ mA}$: accuracy reduces in proportion to I_m . e. g. $I_m = 0.1 \text{ mA}$: ± 1 % of R_m or 1 Ω (the larger value is applicable).
Influence of ambient temperature		$I_m \geq 1 \text{ mA}$, $R_m \geq 100 \Omega$: 0.01 %/K in the range -20 ... +60 °C (253 ... 333 K) $I_m < 1 \text{ mA}$ or $R_m < 100 \Omega$: temperature stability reduces in proportion to I_m or R_m
Rise time		signal response time ≤ 2 ms (10 ... 90 %) response to application of I_m : $R_m > 50 \Omega$ and $I_m < 5 \text{ mA}$: < 5ms response to application of I_m : $R_m > 30 \Omega$ and $I_m < 5 \text{ mA}$: < 10ms response to application of I_m : $R_m > 18 \Omega$ and $I_m < 5 \text{ mA}$: < 20ms
Galvanic isolation		
Input/Output		reinforced insulation acc. to EN 50178, rated insulation voltage 300 V _{eff}
Input/power supply		reinforced insulation acc. to EN 50178, rated insulation voltage 300 V _{eff}
Output/power supply		functional insulation, rated insulation voltage 50 V AC
Directive conformity		
Electromagnetic compatibility		
Directive 2004/108/EC		EN 61326-1:2013 (industrial locations)
Conformity		
Electromagnetic compatibility		NE 21
Degree of protection		IEC 60529
Protection against electrical shock		EN 61010-1
Ambient conditions		
Ambient temperature		-20 ... 60 °C (-4 ... 140 °F)
Mechanical specifications		
Degree of protection		IP20
Mass		approx. 100 g
Dimensions		12.5 x 114 x 124 mm (0.5 x 4.5 x 4.9 inch), housing type A2
Mounting		on 35 mm DIN mounting rail acc. to EN 60715:2001
Data for application in connection with hazardous areas		
EU-type examination certificate		BASEEFA 10 ATEX 0061, for additional certificates see www.pepperl-fuchs.com
Marking		⊕ II (1)G [Ex ia Ga] IIC, ⊕ II (1)D [Ex ia Da] IIIC, ⊕ I (M1) [Ex ia Ma] I
Input		[Ex ia Ga] IIC, [Ex ia Da] IIIC, [Ex ia Ma] I
Voltage	U_o	12.4 V
Current	I_o	17.4 mA
Power	P_o	54 mW
Supply		
Maximum safe voltage	U_m	253 V (Attention! The rated voltage can be lower.)
Type of protection [EEx ia]		
Output		
Maximum safe voltage	U_m	253 V (Attention! The rated voltage can be lower.)
Certificate		BASEEFA 10 ATEX 0062X, observe statement of conformity
Marking		⊕ II 3G Ex nA IIC T4 Gc
Galvanic isolation		
Input/Output		safe electrical isolation acc. to IEC/EN 60079-11, voltage peak value 375 V
Input/power supply		safe electrical isolation acc. to IEC/EN 60079-11, voltage peak value 375 V

Release date 2019-08-20 09:18 Date of issue 2019-08-20 240635_eng.xml

Refer to "General Notes Relating to Pepperl+Fuchs Product Information".

Directive conformity	
Directive 94/9/EC	EN 60079-0:2012+A11:2013 , EN 60079-11:2012 , EN 60079-15:2010
International approvals	
IECEX approval	IECEX BAS 10.0024 IECEX BAS 10.0025X
Approved for	[Ex ia Ga] IIC, [Ex ia Da] IIIC, [Ex ia Ma] I , Ex nA IIC T4 Gc
General information	
Supplementary information	EC-Type Examination Certificate, Statement of Conformity, Declaration of Conformity, Attestation of Conformity and instructions have to be observed where applicable. For information see www.pepperl-fuchs.com .
Accessories	
Optional accessories	<ul style="list-style-type: none"> - power feed module KFD2-EB2(.R4A.B)(.SP) - universal power rail UPR-03(-M)(-S) - profile rail K-DUCT-BU(-UPR-03) - insertion bridge EBP 2- 5

Release date 2019-08-20 09:18 Date of issue 2019-08-20 240635_eng.xml

Refer to "General Notes Relating to Pepperl+Fuchs Product Information".

Pepperl+Fuchs Group
www.pepperl-fuchs.com

USA: +1 330 486 0002
pa-info@us.pepperl-fuchs.com

Germany: +49 621 776 2222
pa-info@de.pepperl-fuchs.com

Singapore: +65 6779 9091
pa-info@sg.pepperl-fuchs.com

Additional information

Function

When a signal converter, a DCS or PLC is connected to terminals 5, 6, 7, and 8 (control side), the measuring current is transferred to terminals 2 and 4 (field side). The resulting voltage at terminals 1, and 3 is transferred to terminals 5, 6, 7, and 8. In the case of fast multiplex input cards, transmission problems might be experienced in connection with low resistance values and/or high sensor currents. For data see rise time.

The quoted accuracy is for a 4-wire technique connection. The accuracy in 3-wire technique will depend on the matching of the line resistance.

Connection types control side (safe area)

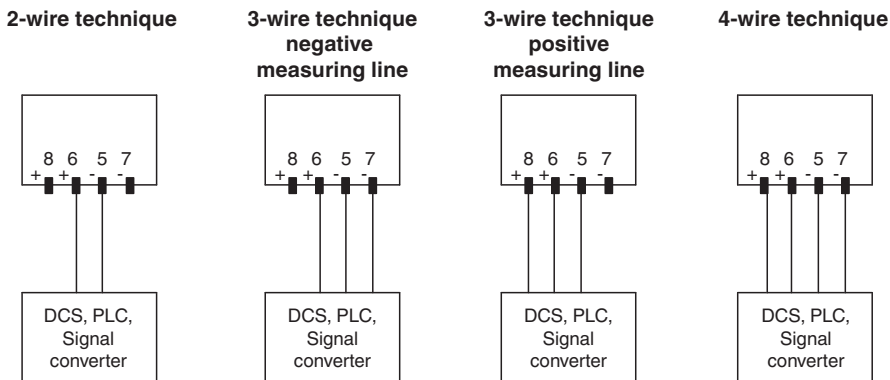

Connection types field side (hazardous area)

The resistance in the hazardous area can be measured with a 2-, 3- or 4-wire technique.

- 2-wire technique: Link terminals 1 and 2 and terminals 3 and 4. Connect the resistance to terminal 4 and terminal 2. Switch S1 in the position II.
- 3-wire technique: Link terminals 1 and 2. Connect the resistance to terminals 3 and 4 and terminal 2. Switch S1 in the position I.
- 4-wire technique: Connect the resistance to terminals 3 and 4 and terminals 1 and 2. Switch S1 in the position II.

Measurement range

The resistance repeater can convey a maximum of 10 mA and a maximum of 7 V. The maximum connectable resistance value can be calculated with the following equations

- Resistance value = 7 V / measuring current
- Resistance value = 9 V / measuring current - 758 Ω

Use the smaller of these two resistance values as maximum allowed load.

The measuring current is determined by control.

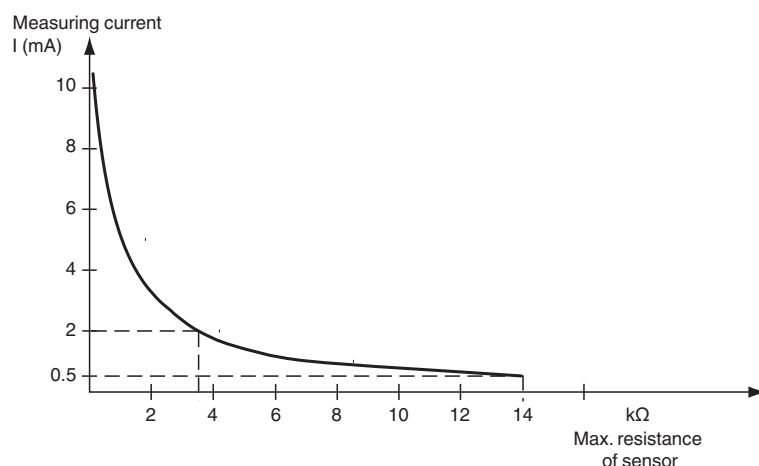

An example of the maximum transferable resistance value:

- 14 kΩ at 0.5 mA measuring current
- 3.5 kΩ at 2 mA measuring current

Release date 2019-08-20 09:18 Date of issue 2019-08-20 240635_eng.xml

Refer to "General Notes Relating to Pepperl+Fuchs Product Information".

Line Fault Detection (LFD)

The output will indicate less than 10 Ω or greater than 400 Ω for a lead breakage at terminals 1, 2, 3 or 4 for measuring current of less than or equal to 1 mA i.e. out of range for Pt100.