

Connections

NON-HAZARDOUS LOCATION or
HAZARDOUS LOCATION
Class I, Division 1, Groups A, B, C, D
Class II, Division 1, Groups E, F, G
Class III, Division 1 or
Class I, Zone 0 and 1, IIC
Zone 20 and 21, IIC

NON-HAZARDOUS LOCATION or
HAZARDOUS LOCATION
Class I, Division 2, Groups A, B, C, D or
Class I, Zone 2, IIC

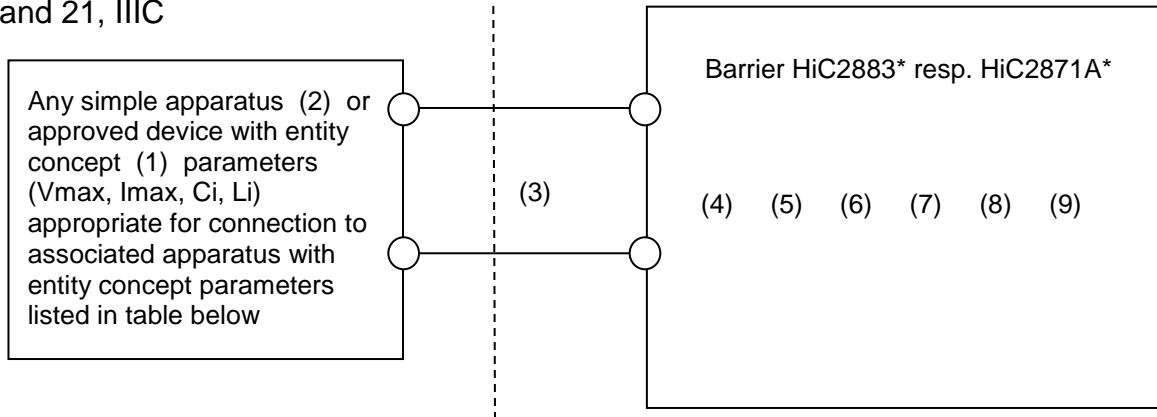

Notes

- The Entity Concept allows interconnection of intrinsically safe apparatus with associated apparatus not specifically examined in combination as a system when the approved values of V_{oc} (or U_o) and I_{sc} (or I_o) for the associated apparatus are less than or equal to V_{max} (U_i) and I_{max} (I_i) for the intrinsically safe apparatus and the approved values of C_a (C_o) and L_a (L_o) for the associated apparatus are greater than $C_i + C_{cable}$ and $L_i + L_{cable}$, respectively, for the intrinsically safe apparatus,
Where $C_{cable} = 60pF/ft$ if unknown
Where $L_{cable} = 0.20uH/ft$ if unknown
- Simple apparatus: an electrical component or combination of components of simple construction with well-defined electrical parameters that does not generate more than 1.5 V, 100mA, 25mW, or is a passive component that does not dissipate more than 1.3W and is compatible with the intrinsic safety of the circuit in which it is used.
- Wiring methods must be in accordance with all applicable installation requirements of the country in use. For US, this is NFPA 70 (NEC) article 504 with additional information in ANSI-ISA –RP12.06.01. For Canada this is CSA 22.1-12 (CEC) section 18 and appendix F.
- Barriers shall not be connected to any device which uses or generates internally any voltage in excess of 60V unless the device has been determined to adequately isolate the voltage from the barrier.
- The device can only be used in an area of not more than Pollution degree 2.
- The barriers are rated 'non-incendive' for use in Class I, Division 2 or Zone 2. A temperature rating of T4 applies to all non-incendive rated barriers.
- If the barriers are intended to be mounted in a Division 2 location, they shall be mounted within a tool-secured enclosure which is capable of accepting one or more of the Class I, Division 2 wiring methods specified in the National Electrical Code (ANSI/NFPA 70) or Canadian Electrical Code (C22.1), as applicable. The equipment shall be installed in an enclosure with a minimum ingress protection of IP2X.
- If the barriers are intended to be mounted in a Zone 2 location, they shall be mounted within a tool-secured enclosure which

This document contains safety-relevant information. It must not be altered without the authorization of a NE EX		
	Only valid as long as released in EDM	date: 2017-Jun-29
	FM Control drawing	116-0442
	HiC2883*, HiC2871A*	sheet 1 of 2
Global		

is capable of accepting one or more of the Class I, Zone 2 wiring methods specified in the National Electrical Code (ANSI/NFPA 70) or Canadian Electrical Code (C22.1), as applicable. The equipment shall be installed in an AEx or Ex certified IP54 enclosure unless the apparatus is intended to be afforded an equivalent degree of protection by location.

9. The permitted ambient temperature range for HiC2883*:
 -20°C to +60°C if installed in Zone 2/Div. 2
 -20°C to +70°C if installed in ordinary location

The permitted ambient temperature range for HiC2871A*:
 -20°C to +70°C if installed in Zone 2/Div. 2 or ordinary location

Entity Parameters

Model Number	Terminals	U _o (V)	I _o (mA)	P _o (mW)	Co (nF)			Lo (mH)		
					A,B IIC	C,E,F,G IIB, IIIC	D IIA	A,B IIC	C,E,F,G IIB	D IIA
HiC2883*	5a, 5b	26	110	715	99	770	2600	2,9	11,7	23,5
HiC2871A*										

The values of Lo and Co listed in the table above are allowed if one of the following conditions is met:

- the total Li of the external circuit (excluding the cable) is < 1% of the Lo value or
- the total Ci of the external circuit (excluding the cable) is < 1% of the Co value.

The values of Lo and Co listed in the table above shall be reduced to 50% when both of the following conditions are met:

- the total Li of the external circuit (excluding the cable) is ≥ 1% of the Lo value and
- the total Ci of the external circuit (excluding the cable) is ≥ 1% of the Co value.

Note: the reduced capacitance of the external circuit (including cable) shall not be greater than 1uF for IIA, IIB and 600nF for IIC.

WARNING - Substitution of components may impair intrinsic safety and suitability for use in Class I, Div. 2/Zone 2.

AVERTISSEMENT - La substitution de composants peut compromettre la sécurité intrinsèque et l'adéquation à une utilisation en Classe I, Div. 2/Zone 2.

WARNING - Do not disconnect the equipment or actuate switches when the equipment is energized and an explosive atmosphere is present.

AVERTISSEMENT - Ne pas débrancher l'équipement et ne pas actionner les commutateurs lorsque l'équipement est sous tension et exposé à une atmosphère explosive.

This document contains safety-relevant information. It must not be altered without the authorization of a NE EX		
	Only valid as long as released in EDM	date: 2017-Jun-29
 PEPPERL+FUCHS	FM Control drawing	116-0442
	HiC2883*, HiC2871A*	sheet 2 of 2
Global		