

## Elektrischer Anschluss

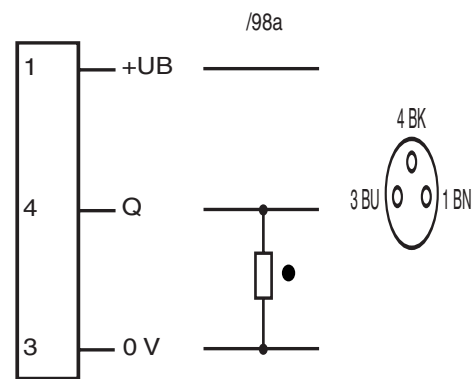

● = dunkelschaltend, ○ = hellerhaltend

## Electrical connection

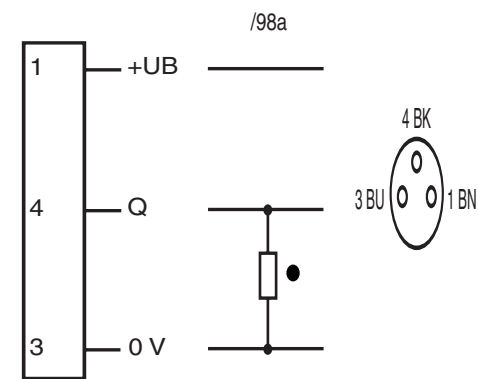

● = dark on, ○ = light on

## Adressen/Addresses

**Worldwide Head Office**  
Pepperl+Fuchs GmbH  
Koenigsberger Allee 87  
68307 Mannheim  
Germany  
Telephone: +49 621 776-0  
Telefax: +49 621 776-1000  
eMail: info@de.pepperl-fuchs.com

**USA Head Office**  
Pepperl + Fuchs Inc.  
1600 Enterprise Parkway  
TWINSBURG OHIO, 44087  
USA  
Telephone +1 330 425-3555  
Telefax +1 330 425-4607  
eMail sales@us.pepperl-fuchs.com

**Asia Pacific Head Office**  
Pepperl + Fuchs PTE LTD  
P+F Building  
18 Ayer Rajah Crescent  
139942 SINGAPORE  
Singapore  
Company Registration No. 199003130E  
Telephone +65 6779 9091  
Telefax +65 6873 1637  
eMail sales@sg.pepperl-fuchs.com

<http://www.pepperl-fuchs.com>

Gabellichtschranke  
Fork type light beam switch

GL50-RT/32/40a/98a



Doc. No.: 45-1084A  
DIN A3 -> DIN A7

Part. No.: 130176  
Date: 05/31/2005



## Technische Daten

Allgemeine Daten	
Lichtsender	LED
Zulassungen	CE, cULus
Prüfungen	EN 60947-5-2
Kennzeichnung	
Hindernisgröße	0,5 mm
Gabelweite	50 mm
Lichtart	rot, Wechsellicht
Fremdlichtgrenze	100000 Lux
Anzeigen/Bedienelemente	
Funktionsanzeige	LED rot im Anschlussstecker, leuchtet bei freiem Lichtstrahl
Bedienelemente	Empfindlichkeitseinsteller, Hell-/Dunkel-Umschalter
Elektrische Daten	
Betriebsspannung	10 ... 30 V DC, class 2
Welligkeit	10 %
Leerlaufstrom	$I_0$ 25 mA
Ausgang	
Schaltungsart	hell-/dunkelschaltend
Signalausgang	1 pnp, kurzschlussfest, offener Kollektor
Schaltspannung	max. 30 V DC
Schaltstrom	max. 200 mA
Schaltfrequenz	f 350 Hz
Ansprechzeit	1 ms
Umgebungsbedingungen	
Umgebungstemperatur	-20 ... 60 °C (253 ... 333 K)
Lagertemperatur	-20 ... 75 °C (253 ... 348 K)
Mechanische Daten	
Schutzart	IP67
Anschluss	M8-Stecker, 3-polig
Material	
Gehäuse	Aluminium
Lichtaustritt	Glas
Masse	60 g

## Technical data

General specifications	
Light source	LED
Approvals	CE, cULus
Tests	EN 60947-5-2
Marking	
Obstacle size	0,5 mm
Fork width	50 mm
Light type	red, modulated light
Ambient light limit	100000 Lux
Indicators/operating means	
Function display	LED red in the connector plug, illuminates with free light beam
Operating elements	Sensitivity adjuster, light/dark switch
Electrical specifications	
Operating voltage	10 ... 30 V DC, class 2
Ripple	10 %
No-load supply current	$I_0$ 25 mA
Output	
Switching type	light/dark switching
Signal output	1 pnp, short-circuit proof, open collector
Switching voltage	max. 30 V DC
Switching current	max. 200 mA
Switching frequency	f 350 Hz
Response time	1 ms
Ambient conditions	
Ambient temperature	-20 ... 60 °C (253 ... 333 K)
Storage temperature	-20 ... 75 °C (253 ... 348 K)
Mechanical specifications	
Protection degree	IP67
Connection	M8 connector, 3-pin
Material	
Housing	aluminium
Optical face	glass
Mass	60 g

## Sicherheitshinweise:

- Vor der Inbetriebnahme Betriebsanleitung lesen
- Anschluss, Montage und Einstellung nur durch Fachpersonal
- Kein Sicherheitsbauteil gemäß EU-Maschinenrichtlinie, darf nicht für Personenschutz oder NOT-AUS-Funktion verwendet werden.

## Security Instructions:

- Read the operating instructions before attempting commissioning
- Installation, connection and adjustments should only be undertaken by specialist personnel
- No safety compolltction of personnel or EMERGENCY-STOP functions.

## Abmessungen

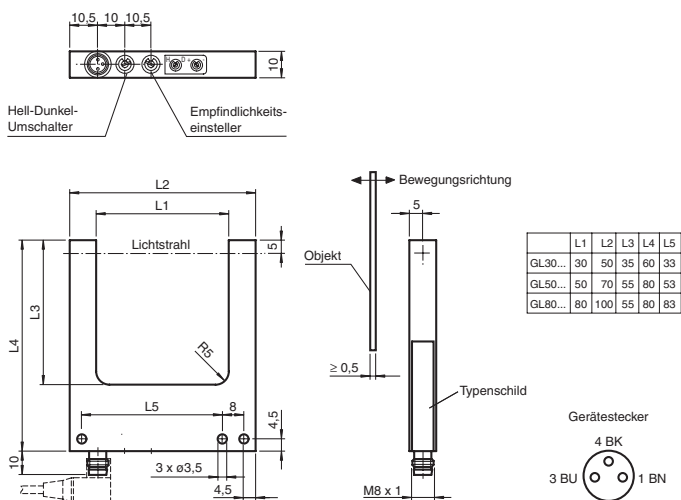

alle Maße in mm

## Dimensions

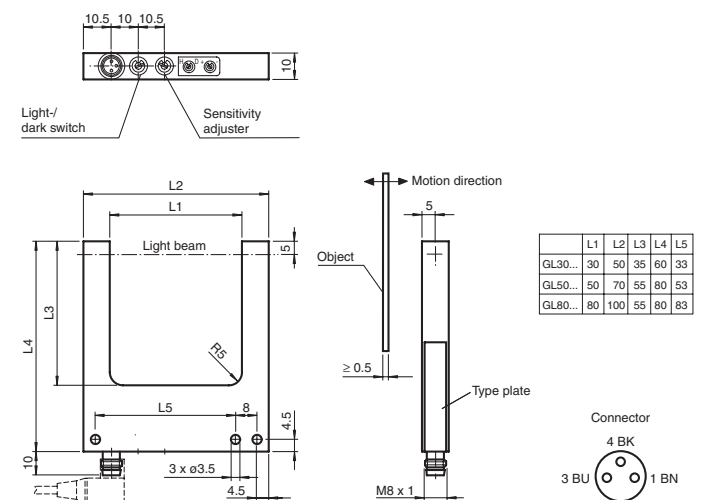

all dimensions in mm

\_\_\_\_\_

\_\_\_\_\_