

Elektrischer Anschluss

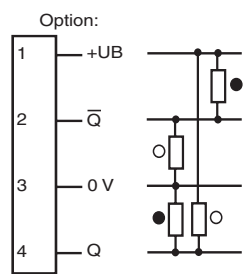

Electrical connection

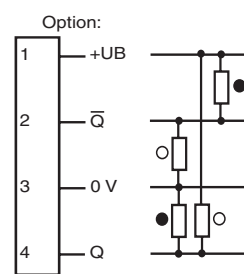

○ = Hellschaltung
● = Dunkelschaltung



○ = Light on
● = Dark on

Adressen/Addresses



Pepperl+Fuchs GmbH
68301 Mannheim · Germany
Tel. +49 621 776-4411
Fax +49 621 776-27-4411
E-mail: fa-info@de.pepperl-fuchs.com

Worldwide Headquarters
Pepperl+Fuchs GmbH · Mannheim · Germany
E-mail: fa-info@de.pepperl-fuchs.com

USA Headquarters
Pepperl+Fuchs Inc. · Twinsburg · USA
E-mail: fa-info@us.pepperl-fuchs.com

Asia Pacific Headquarters
Pepperl+Fuchs Pte Ltd · Singapore
E-mail: fa-info@sg.pepperl-fuchs.com
Company Registration No. 199003130E

www.pepperl-fuchs.com

Reflexions-Lichtschränke
mit Gerätestecker M8 x 1, 4-polig
Retroreflective sensor
with 4-pin, M8 x 1 connector
ML9-54-G/25/136/143



Part. 194197
Date: 07/23/2014

Doc. 45-2315B
DIN A3 -> A7



PEPPERL+FUCHS
SENSING YOUR NEEDS

Technische Daten

Allgemeine Daten

Betriebsreichweite	0 ... 3,5 m im Teach-Betrieb 0 ... 5,7 m im Normalmodus
Reflektorabstand	0 ... 3,5 m im Teach-Betrieb 0 ... 5,7 mm im Normalmodus
Grenzreichweite	7,6 m
Referenzobjekt	Reflektor H85-2
Lichtsender	LED
Lichtart	rot, Wechsellicht , 660 nm
Polarisationsfilter	ja
Winkelabweichung	max. ± 1°
Lichtfleckdurchmesser	ca. 40 mm bei Reichweite 1 m
Öffnungswinkel	1,7°
Fremdlichtgrenze	40000 Lux

Kenndaten funktionale Sicherheit

MTTF _d	1050 a
Gebrauchsdauer (T _M)	20 a
Diagnosedeckungsgrad (DC)	0 %

Anzeigen/Bedienelemente

Betriebsanzeige	LED grün, statisch leuchtend Power on , Unterspannungsanzeige: LED grün pulsierend (ca. 0,8 Hz) , Kurzschluss : LED grün blinkend (ca. 4 Hz)
Funktionsanzeige	LED gelb: Schaltzustand ; Funktionsreserve ; Teach-In
Bedienelemente	Teach-In-Taste
Kontrasterkennungsstufen	10 % - saubere, wassergefüllte PET-Flaschen

Elektrische Daten

Betriebsspannung	U _B	10 ... 30 V DC , class 2
Welligkeit		max. 10 %
Leerlaufstrom	I ₀	< 20 mA bei 24 V DC

Ausgang

Schaltungsart	hellschaltend	
Signalausgang	2 Gegentaktgänge, antivalent, kurzschlussfest, verpolgeschützt	
Schaltspannung	max. 30 V DC	
Schaltstrom	max. 100 mA	
Schaltfrequenz	f	1000 Hz
Ansprechzeit		500 µs

Umgebungsbedingungen

Umgebungstemperatur	-20 ... 60 °C (-4 ... 140 °F)
Lagertemperatur	-40 ... 75 °C (-40 ... 167 °F)

Mechanische Daten

Schutzart	IP67
Anschluss	Gerätestecker M8 x 1, 4-polig
Material	
Gehäuse	PC (Makrolon, glasfaserverstärkt)
Lichtaustritt	Glas
Stecker	Kunststoff
Masse	ca. 25 g

Normen- und Richtlinienkonformität

Normenkonformität	
Produktnorm	EN 60947-5-2:2007 IEC 60947-5-2:2007 EN 50178, UL 508

Zulassungen und Zertifikate

Schutzklasse	II, Bemessungsspannung ≤ 50 V AC bei Verschmutzungsgrad 1-2 nach IEC 60664-1 Funktionsisolierung nach DIN EN 50178
UL-Zulassung	cULus
CCC-Zulassung	Produkte, deren max. Betriebsspannung ≤ 36 V ist, sind nicht zulassungspflichtig und daher nicht mit einer CCC-Kennzeichnung versehen.

Technical data

General specifications

Effective detection range	0 ... 3.5 m in TEACH mode 0 ... 5.7 m in normal mode
Reflector distance	0 ... 3.5 m in TEACH mode 0 ... 5.7 mm in normal mode
Threshold detection range	7.6 m
Reference target	H85-2 reflector
Light source	LED
Light type	modulated visible red light , 660 nm
Polarization filter	yes
Angle deviation	max. ± 1°
Diameter of the light spot	approx. 40 mm at detection range 1 m
Angle of divergence	1.7°
Ambient light limit	40000 Lux

Functional safety related parameters

MTTF _d	1050 a
Mission Time (T _M)	20 a
Diagnostic Coverage (DC)	0 %

Indicators/operating means

Operation indicator	LED green, statically lit Power on , Undervoltage indicator: Green LED, pulsing (approx. 0.8 Hz) , short-circuit : LED green flashing (approx. 4 Hz)
Function indicator	LED yellow: switching state ; Stability control ; Teach-In
Control elements	Teach-In key
Contrast detection levels	10 % - clean, water filled PET bottles

Electrical specifications

Operating voltage	U _B	10 ... 30 V DC , class 2
Ripple		max. 10 %
No-load supply current	I ₀	< 20 mA at 24 V DC

Output

Switching type	light on	
Signal output	2 push-pull (4 in 1) outputs, complementary, short-circuit proof, reverse polarity protected	
Switching voltage	max. 30 V DC	
Switching current	max. 100 mA	
Switching frequency	f	1000 Hz
Response time		500 µs

Ambient conditions

Ambient temperature	-20 ... 60 °C (-4 ... 140 °F)
Storage temperature	-40 ... 75 °C (-40 ... 167 °F)

Mechanical specifications

Degree of protection	IP67
Connection	M8 x 1 connector, 4-pin
Material	
Housing	PC (glass-fiber-reinforced Makrolon)
Optical face	glass
Connector	plastic
Mass	approx. 25 g

Compliance with standards and directives

Standard conformity	
Product standard	EN 60947-5-2:2007 IEC 60947-5-2:2007 EN 50178, UL 508

Approvals and certificates

Protection class	II, rated voltage ≤ 50 V AC with pollution degree 1-2 according to IEC 60664-1 functional insulation acc. to DIN EN 50178
UL approval	cULus
CCC approval	CCC approval / marking not required for products rated ≤ 36 V

Sicherheitshinweise:

- Vor der Inbetriebnahme Betriebsanleitung lesen
- Anschluss, Montage und Einstellung nur durch Fachpersonal
- Kein Sicherheitsbauteil gemäß EU-Maschinenrichtlinie

Abmessungen

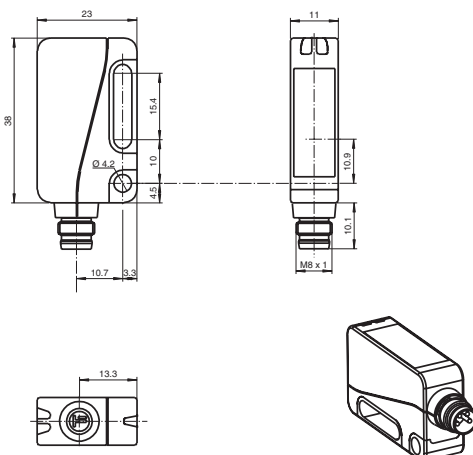

alle Maße in mm

Security Instructions:

- Read the operating instructions before attempting commissioning
- Installation, connection and adjustments should only be undertaken by specialist personnel
- Not a safety component in accordance with the EU Machinery Directive

Dimensions

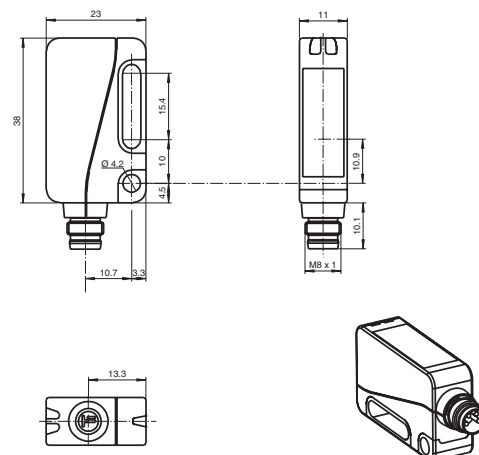

all dimensions in mm

Anzeigen/Bedienelemente

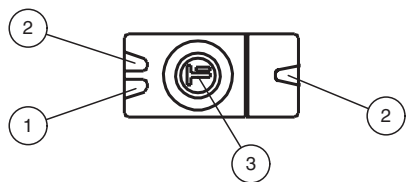

1	LED grün
2	LED gelb
3	Teach-In

Indicators/operating means

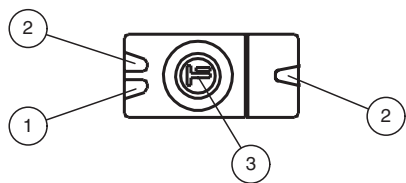

1	LED green
2	LED yellow
3	Teach-In

Charakteristische Ansprechkurve Courbe de response caractéristique Curve di risposta caratteristica

Characteristic response curve Curva de respuesta característica

Möglicher Abstand (Versatz) zwischen optischer Achse und Referenzobjekt.

Permissible distance (offset) between optical axis and reference target.

Ecart possible entre l'axe optique et la cible de référence.

Desplazamiento entre el eje óptico y objeto de referencia.

Distanza possibile (sfalsato) tra l'asse ottico e l'oggetto di riferimento.

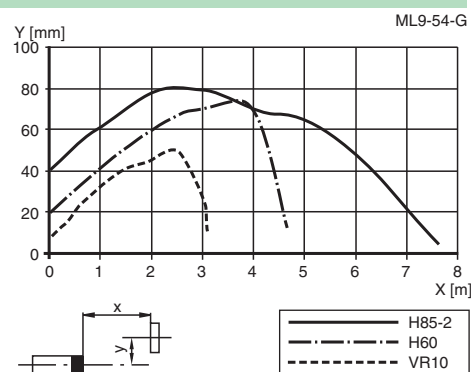

Relative Empfangslichtstärke Intensité relative de la lumière reçue Intensità relativa luce in ricezione

Relative received light strength Potencia relativa de recepción lumínica

Funktionsreserve, Stability control, Réserve de fonctionnement, Reserva de función, Funzione riserva

ML9-54-G

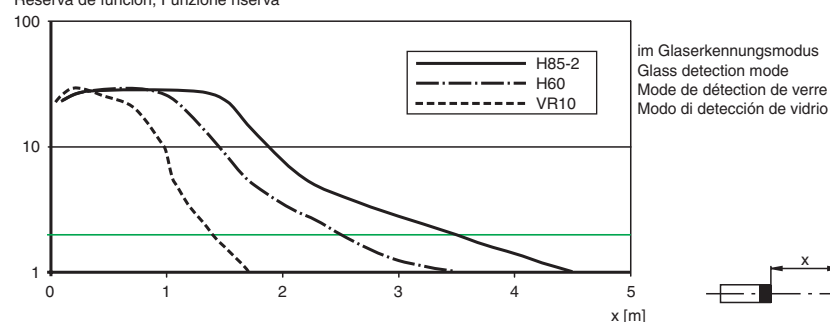

Relative Empfangslichtstärke Intensité relative de la lumière reçue Intensità relativa luce in ricezione

Relative received light strength Potencia relativa de recepción lumínica

Funktionsreserve, Stability control, Réserve de fonctionnement, Reserva de función, Funzione riserva

ML9-54-G

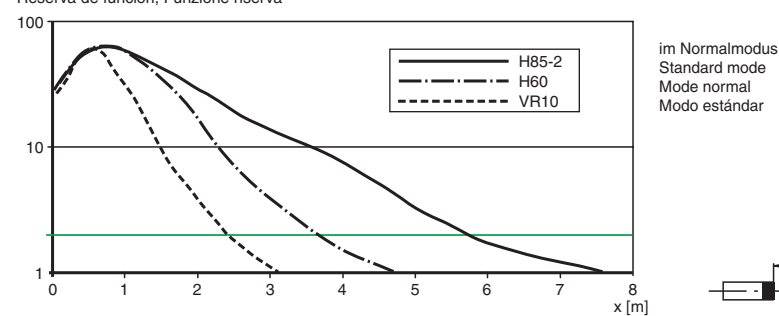

Einstellhinweise/Adjustment instructions

D

Einstellanweisung für Geräte mit Teach-In

Nach Anlegen der Betriebsspannung leuchtet die LED grün. Der Sensor ist automatisch im Zustand max. Empfindlichkeit (Auslieferungszustand) bzw. im Zustand der letzten Teach-In Einstellung. Montieren Sie den geeigneten Reflektor gegenüber der Lichtschranke.

Teach-In über Teach-Taste

- Den Sensor auf einen geeigneten Reflektor ausrichten.
- Teach-Taste drücken - zur Bestätigung geht die grüne Anzeige-LED einmal kurz aus.
- Teach-Taste solange gedrückt halten bis die gelbe und grüne Anzeige-LED im Gleichtakt blinken (ca. 2,5 Hz). Danach die Teach-Taste loslassen.
- Während des internen Set-Up des Sensors blinken die grüne und gelbe Anzeige-LED abwechselnd (ca. 2,5 Hz).
- Teach-In erfolgreich: Die grüne und gelben Anzeige-LEDs leuchten. Kontrasterkennung 10% ist aktiviert. Das Gerät ist betriebsbereit.
- Teach-In nicht erfolgreich: Die grüne und gelben Anzeige-LEDs blinken schnell abwechselnd (ca. 8 Hz) für ca. 5 Sekunden. Der Sensor geht anschließend in den Zustand mit max. Empfindlichkeit. Danach die Teach-In Prozedur wiederholen, beginnend mit Schritt 1.

GB

Adjustment instructions for devices with Teach-In

After the operating voltage has been applied, the LED is lit green. The sensor is automatically set to a state of maximum sensitivity (state as supplied) or the state of the most recent Teach-In setting. Assemble the appropriate reflector opposite the light barrier.

Teach-In using the Teach key

- Align the sensor to an appropriate reflector.
- Press the Teach key - as confirmation, the green display LED is briefly turned off once.
- Hold the Teach key down until the yellow and green display LED is flashing at regular intervals (about 2.5 Hz). Then release the Teach key.
- During the internal set-up of the sensor, the green and yellow display LEDs flash alternately (about 2.5 Hz).
- Teach-In successful: The green and yellow display LEDs are lit. Contrast detection 10% is activated. The device is ready for operation.
- Teach-In not successful: The green and yellow display LEDs flash alternately and rapidly (about 8 Hz) for about 5 seconds. Then the sensor goes to the state with maximum sensitivity. After this happens, repeat the Teach-In procedure, starting with step 1.