

## Elektrischer Anschluss

## Electrical connection

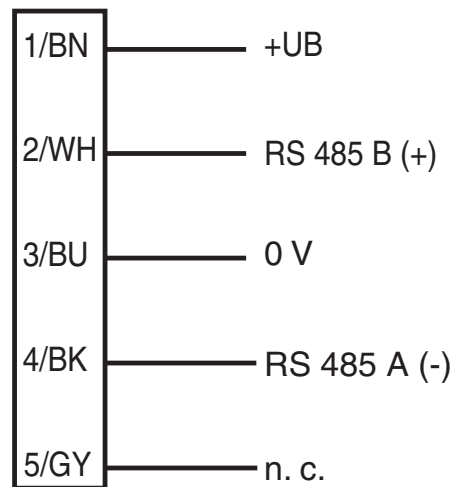
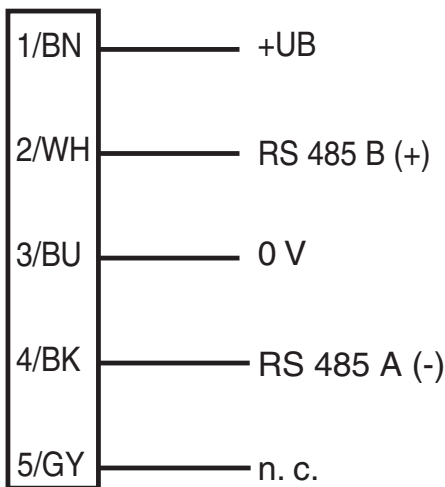

● = dunkelschaltend, ○ = hellerschaltend

● = dark on, ○ = light on



## Technische Daten

Allgemeine Daten	
Referenzobjekt	Reflektor H100-2R
Lichtsender	Laserdiode
Lichtart	infrarot, Wechslicht
Laserkerndaten	
Laserklasse	1
Wellenlänge	900 nm
Strahldivergenz	120 mrad
Impulsdauer	≤ 8 ns
Wiederholrate	≥ 4 kHz
Maximale optische Ausgangsleistung	2,6 W
Zulassungen	CE
Messverfahren	Pulse Ranging Technology (PRT)
Messbereich	0 ... 6 m
Fremdlichtgrenze	Halogenlicht 50000 Lux
Anzeigen/Bedienelemente	
Betriebsanzeige	LED grün
Elektrische Daten	
Betriebsspannung $U_B$	18 ... 30 V DC
Welligkeit	10 % innerhalb der Versorgungstoleranz
Leerlaufstrom $I_0$	≤ 200 mA
Bereitschaftsverzug $t_v$	≤ 300 ms
Schnittstelle	
Schnittstellentyp	RS 485
Ausgang	
Schnittstellen	RS 485
Baudrate	57,6 kBaud (werksseitige Einstellung)
Schaltstrom	max. 200 mA
Spannungsfall $U_d$	≤ 2,4 V
Umgebungsbedingungen	
Umgebungstemperatur	0 ... 50 °C (273 ... 323 K)
Lagertemperatur	-20 ... 70 °C (253 ... 343 K)
Mechanische Daten	
Schutzart	IP54
Anschluss	Gerätestecker M12 x 1, 5-polig
Material	
Gehäuse	ABS
Masse	200 g
Normen- und Richtlinienkonformität	
Richtlinienkonformität	
EMV-Richtlinie 2004/108/EG	EN 60947-5-2
Normenkonformität	
Laserklasse	IEC 60825-1:2007

## Sicherheitshinweise:

- Vor der Inbetriebnahme Betriebsanleitung lesen
- Anschluss, Montage und Einstellung nur durch Fachpersonal
- Kein Sicherheitsbauteil gemäß EU-Maschinenrichtlinie

## Abmessungen

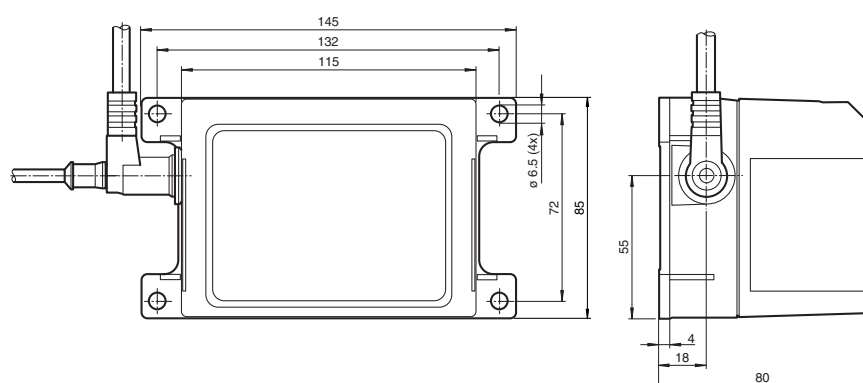

alle Maße in mm

## Adressen/Addresses



Pepperl+Fuchs GmbH  
 68301 Mannheim · Germany  
 Tel. +49 621 776-4411  
 Fax +49 621 776-27-4411  
 E-mail: fa-info@de.pepperl-fuchs.com

**Worldwide Headquarters**  
 Pepperl+Fuchs GmbH · Mannheim · Germany  
 E-mail: fa-info@de.pepperl-fuchs.com

**USA Headquarters**  
 Pepperl+Fuchs Inc. · Twinsburg · USA  
 E-mail: fa-info@us.pepperl-fuchs.com

**Asia Pacific Headquarters**  
 Pepperl+Fuchs Pte Ltd · Singapore  
 E-mail: fa-info@sg.pepperl-fuchs.com  
 Company Registration No. 199003130E

[www.pepperl-fuchs.com](http://www.pepperl-fuchs.com)

Distanzsensor  
 Distance sensor

VDM54-6000-R/20/88/105



Doc. No.: 45-2413A  
 DIN A3 -> DIN A7

Part. No.: 194907  
 Date: 03/10/2010

**PEPPERL+FUCHS**  
 SENSING YOUR NEEDS

## Technical data

General specifications	
Reference target	Reflector H100-2R
Light source	laser diode
Light type	infrared, modulated light
Laser nominal ratings	
Laser class	1
wave length	900 nm
Beam divergence	120 mrad
Pulse length	≤ 8 ns
Repetition rate	≥ 4 kHz
Maximum optical power output	2.6 W
Approvals	
Measuring method	Pulse Ranging Technology (PRT)
Measurement range	0 ... 6 m
Ambient light limit	halogen light 50000 Lux
Indicators/operating means	
Operating display	LED green
Electrical specifications	
Operating voltage $U_B$	18 ... 30 V DC
Ripple	10 % within the supply tolerance
No-load supply current $I_0$	≤ 200 mA
Time delay before availability $t_v$	≤ 300 ms
Interface	
Interface type	RS 485
Output	
Interfaces	RS 485
Baudrate	57.6 kBaud (Factory setting)
Switching current	max. 200 mA
Voltage drop $U_d$	≤ 2.4 V
Ambient conditions	
Ambient temperature	0 ... 50 °C (273 ... 323 K)
Storage temperature	-20 ... 70 °C (253 ... 343 K)
Mechanical specifications	
Protection degree	IP54
Connection	connector M12 x 1, 5-pin
Material	
Housing	ABS
Mass	200 g
Compliance with standards and directives	
Directive conformity	
EMC Directive 2004/108/EC	EN 60947-5-2
Standard conformity	
Laser class	IEC 60825-1:2007

## Security Instructions:

- Read the operating instructions before attempting commissioning
- Installation, connection and adjustments should only be undertaken by specialist personnel
- Not a safety component in accordance with the EU Machinery Directive

## Dimensions

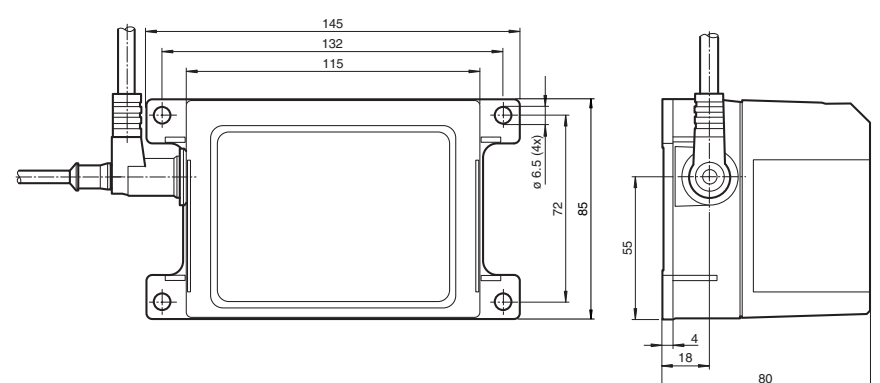

all dimensions in mm

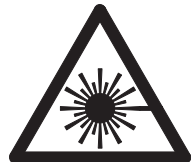
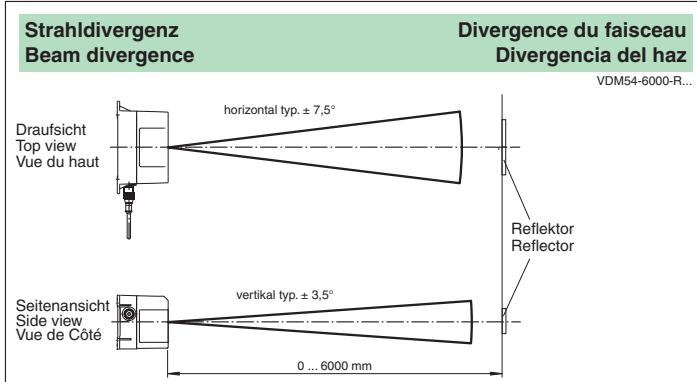
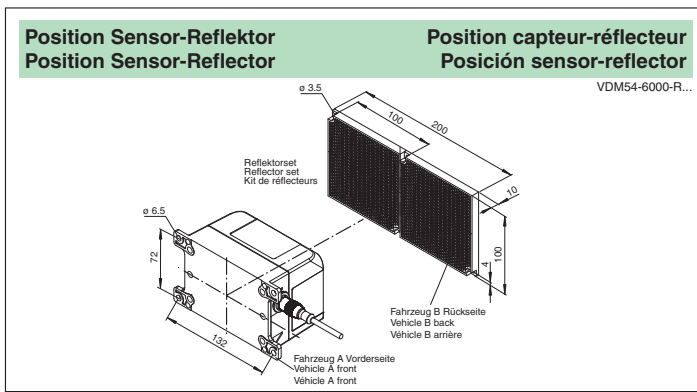

**LASERLICHT  
LASER LIGHT**  
**LASER KLASSE 1  
CLASS 1 LASER PRODUCT**

### Serial communication

#### VDM54-6000-R Transmission frame

The sensor features a half-duplex capable RS-485 interface. This means it is bus-capable but only operates as a slave, i.e. it must be "triggered" by an overriding control operating in master mode in order to be able to send results. The following protocol has been implemented:

- 8 bit data + 1 bit address selection + 1 start/stop bit; at 57,600 baud (1 byte = 9 bit + start + stop bit) (factory default).
- If the 9th bit (address selection) has been set, the slave detects that this byte is an address (ID).

It compares it with its own and, if they match, responds immediately after detecting the frame end of the master. When transmitting data the 9th bit is always reset. The structure of the transmission frame is as follows:

#### In general:

1st byte	2nd byte	3rd byte	....	....	last byte
----------	----------	----------	------	------	-----------

#### Request (from master):

Slave ID	Master ID	Length	Command	Parameter(s)	Checksum (request from master)
----------	-----------	--------	---------	--------------	--------------------------------

#### Answer (from VDM54):

Master ID	Own ID	Length	Command	Parameter(s)	Checksum (answer from slave)
-----------	--------	--------	---------	--------------	------------------------------

#### Where:

- xxx\_id = address or sender (1 byte)
- Length = number of characters sent, incl. frame (1 byte)
- Command = command (1 byte)
- Parameter = 0 ... n, dependent on command (0 ... n byte), nmax = 48
- Checksum = checksum via "Exclusive OR" of all characters sent (1 byte)

Master request (=command) and slave answer are always transmitted in the frame described above. Values expected in reply by the slave are contained in the parameters returned.

The **slave** (VDM54 ...) always returns the actual measured distance as the last two parameter bytes (coding as in the command <C>, i.e. value \*1 mm). Generally, it has the following options for a **reply**:

#### Invalid command ("No Acknowledge"):

Master ID	Own ID	Length=7	Command = 0x15	Distance 2 byte	Checksum
-----------	--------	----------	----------------	-----------------	----------

#### Valid command without parameter return ("Acknowledge"):

Master ID	Own ID	Length=7	Command = 0x06	Distance 2 byte	Checksum
-----------	--------	----------	----------------	-----------------	----------

#### Valid command with parameter return (Valid reply "XON"):

Master ID	Own ID	Length = 7+n	Command = 0x11	N parameter [1 2 3 ... n]	Distance 2 byte	Checksum
-----------	--------	--------------	----------------	---------------------------	-----------------	----------

### Command set

The implemented control commands are described below. All commands modifying the sensor configuration are stored in the permanent memory (flash). This does not, however, apply to command marked with (\*\*)! The communication does not interrupt the continuous measurement.

At the end of the command the new states are accepted during the running operation unless they have been defined to interrupt it (e.g. "RESET").

The following table describes the individual control commands:

Command (4th byte) ASCII	Command [designation]	Master parameter	Description (5th and subsequent bytes) hex
<A>(**)	Select Set (select reception set)	Parameter 1:80h ... 87h	The slave switches its reception segment dependent on the 1st parameter sent by the master (only curve device).
	Reserved	81h	81h
	Reserved	Reserved	
	Reserved	82h(*)	
	Reserved	83h	
	Reserved	84h	
	Reserved	85h	
Reserved	86h		
Reserved	87h		

<B>	Set user baudrate (set user-specific baudrate)	Parameter 1:00h ... FFh (default=0Ah / 57.6 kBaud)	Setting the user-specific baudrate. Parameter 1 from master: 81h 4.8 kBaud 40h 9.6 kBaud 20h 19.2 kBaud 10h 38.4 kBaud 0h 57.6 kBaud 09h 62.5 kBaud
<C>	Get Distance (request distance value)	None	The slave sends as reply in the 1st (higher level) and 2nd (lower level) parameters the actual measured distance (=2 bytes) as an integer multiple of 1 mm. The resolution is limited to 16 mm. The maximum possible distance is: 65535mm. Parameter value for no object detected: 8992
<D>	Delay Set (modify the delay between the end of requests and start of reply)	Parameter 1:00h ... FFh (default = 04h)	Setting the delay between the end of the request and the start of the reply. Approx. 80 µs delay can be set per count.
<E>	Config Own-Id (modify sensor address)	0 ... 255d (default = 222d)	Modify sensor address (Own ID)
<F>	Reserved		
<G>	Reset	None	Reset sensor
<H>-<O>	Reserved		
<P>	Get Power	None	Output actual reception energy
<Q>-<R>	Reserved		
<S>	Strobe	None	Currently without function. Only returns a "valid command"
<T>-<W>	Reserved		
<X>	Get Software Version	None (request version) SW	The slave sends the software version in 3 parameters, example: 5 1 0
<Y>-<Z>	Reserved		

(\*) Basic setting after switching on the operating voltage

(\*\*) The parameters of these commands are only stored in the SPRAM, i.e. they are lost after "RESET"! A permanent storage is only possible via the STROBE command (storage in flash memory)

The "default" values indicate the factory defaults. Reserved commands must not be used!

#### Notes on distance measuring

The resolution is limited to 16 mm.

Proximity range: For distances < 200 mm the sensor issues the value 0 measured in relation to the reflector.

This corresponds to an emergency shut-down in the proximity range.

Distant range: For distances > 6100 mm the sensor issues the value 8992 if the reflector H100-2R has sufficient energy