

Elektrischer Anschluss

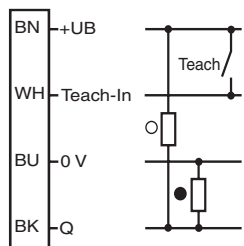

Electrical connection

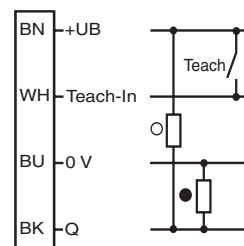

○ = Hellschaltung
● = Dunkelschaltung

○ = Light on
● = Dark on

Technische Daten

Allgemeine Daten	
Betriebsreichweite	0 ... 3,2 m im Teach-Betrieb 0 ... 4 m bei Betriebsart "N"
Reflektorabstand	0 ... 3,2 m im Teach-Betrieb 0 ... 4 m bei Betriebsart "N"
Grenzreichweite	5,1 m
Referenzobjekt	Reflektor H85-2
Lichtsender	LED
Lichtart	rot, Wechsellicht, 660 nm
Winkelabweichung	max. ± 1°
Lichtflechtdurchmesser	ca. 40 mm bei Reichweite 1 m
Öffnungswinkel	1,7°
Fremdlichtgrenze	40000 Lux
Anzeigen/Bedienelemente	
Betriebsanzeige	LED grün, statisch leuchtend Power on, Unterspannungsanzeige: LED grün pulsierend (ca. 0.8 Hz), Kurzschluss: LED grün blinkend (ca. 4 Hz)
Funktionsanzeige	LED gelb: Schaltzustand; Funktionsreserve; Teach-In
Bedienelemente	keine
Kontrasterkennungsstufen	10% - saubere, wassergefüllte PET-Flaschen 18% - Klarglasflaschen 40% - Farbglas oder nichttransparente Materialien einstellbar durch externes Teach-In
Elektrische Daten	
Betriebsspannung	U _B 10 ... 30 V DC
Welligkeit	max. 10 %
Leerlaufstrom	I ₀ < 20 mA bei 24 V DC
Eingang	
Funktionseingang	Ext. Teach-In-Eingang (ET)
Ausgang	
Schaltungsart	hellschaltend
Signalausgang	1 Gegentaktausgang, kurzschlussfest, verpolgeschützt
Schaltspannung	max. 30 V DC
Schaltstrom	max. 100 mA
Schaltfrequenz	f 1 kHz
Ansprechzeit	500 µs
Umgebungsbedingungen	
Umgebungstemperatur	-20 ... 60 °C (-4 ... 140 °F)
Lagertemperatur	-40 ... 75 °C (-40 ... 167 °F)
Mechanische Daten	
Montageadapter	Rohrmontage M16 gewinkelt
Schutzart	IP67 / IP69K
Anschluss	Festkabel 2 m
Material	
Gehäuse	Edelstahl 1.4404 / AISI 316L (V4A)
Lichtaustritt	PMMA
Masse	Sensor 100 g, Rohradapter 150 g
Normen- und Richtlinienkonformität	
Normenkonformität	
Produktnorm	EN 60947-5-2:2007
Zulassungen und Zertifikate	
UL-Zulassung	cULus
CCC-Zulassung	Produkte, deren max. Betriebsspannung ≤36 V ist, sind nicht zulassungspflichtig und daher nicht mit einer CCC-Kennzeichnung versehen.

Adressen/Addresses



Pepperl+Fuchs GmbH
68301 Mannheim · Germany
Tel. +49 621 776-4411
Fax +49 621 776-27-4411
E-mail: fa-info@de.pepperl-fuchs.com

Worldwide Headquarters
Pepperl+Fuchs GmbH · Mannheim · Germany
E-mail: fa-info@de.pepperl-fuchs.com

USA Headquarters
Pepperl+Fuchs Inc. · Twinsburg · USA
E-mail: fa-info@us.pepperl-fuchs.com

Asia Pacific Headquarters
Pepperl+Fuchs Pte Ltd · Singapore
E-mail: fa-info@sg.pepperl-fuchs.com
Company Registration No. 199003130E

www.pepperl-fuchs.com

Reflexions-Lichtschranke

Rohrmontage (16 mm) gewinkelt und Festkabelanschluss

Retroreflective sensor

Right-angled 16 mm pipe mount and cable connection

MLE76350-54-G/25/110/115/123



Doc. No.: 45-3624A
DIN A3 -> DIN A7

Part. No.: 224440
Date: 07/25/2011



PEPPERL+FUCHS
SENSING YOUR NEEDS

Technical data

General specifications	
Effective detection range	0 ... 3.2 m in TEACH mode 0 ... 4 m by operating mode "N"
Reflector distance	0 ... 3.2 m in TEACH mode 0 ... 4 m by operating mode "N"
Threshold detection range	5.1 m
Reference target	H85-2 reflector
Light source	LED
Light type	modulated visible red light, 660 nm
Angle deviation	max. ± 1°
Diameter of the light spot	approx. 40 mm at detection range 1 m
Angle of divergence	1.7°
Ambient light limit	40000 Lux
Indicators/operating means	
Operating display	LED green, statically lit Power on, Undervoltage indicator: Green LED, pulsing (approx. 0.8 Hz), short-circuit: LED green flashing (approx. 4 Hz)
Function display	LED yellow: switching state; Stability control; Teach-In
Controls	none
Contrast detection levels	10% - clean, water filled PET bottles 18% - clear glass bottles 40% - colored glass or opaque materials adjustable by external TEACH-IN switch
Electrical specifications	
Operating voltage	U _B 10 ... 30 V DC
Ripple	max. 10 %
No-load supply current	I ₀ < 20 mA at 24 V DC
Input	
Function input	Ext. Teach-In input (ET)
Output	
Switching type	light on
Signal output	1 push-pull output, short-circuit protected, reverse polarity protected
Switching voltage	max. 30 V DC
Switching current	max. 100 mA
Switching frequency	f 1 kHz
Response time	500 µs
Ambient conditions	
Ambient temperature	-20 ... 60 °C (-4 ... 140 °F)
Storage temperature	-40 ... 75 °C (-40 ... 167 °F)
Mechanical specifications	
Mounting adapter	Right-angled 16 mm pipe mount
Protection degree	IP67 / IP69K
Connection	2 m fixed cable
Material	
Housing	Stainless steel 1.4404 / AISI 316L
Optical face	PMMA
Mass	sensor 100 g, Pipe adapter 150 g
Compliance with standards and directives	
Standard conformity	
Product standard	EN 60947-5-2:2007
Approvals and certificates	
UL approval	cULus
CCC approval	Products with a maximum operating voltage of ≤36 V do not bear a CCC marking because they do not require approval.

Sicherheitshinweise:

- Vor der Inbetriebnahme Betriebsanleitung lesen
- Anschluss, Montage und Einstellung nur durch Fachpersonal
- Kein Sicherheitsbauteil gemäß EU-Maschinenrichtlinie

Abmessungen

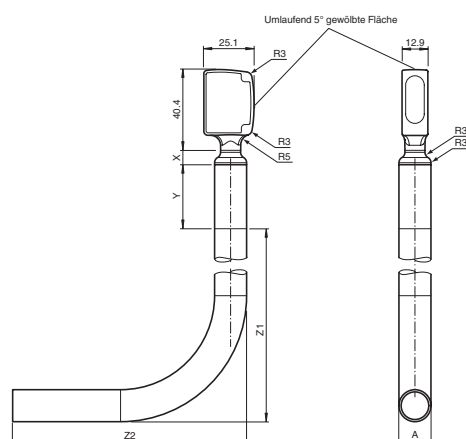

Variables Maß	A	X	Y	Z1	Z2
Standard	ø 16	7.2	32	124	116

Security Instructions:

- Read the operating instructions before attempting commissioning
- Installation, connection and adjustments should only be undertaken by specialist personnel
- Not a safety component in accordance with the EU Machinery Directive

Dimensions

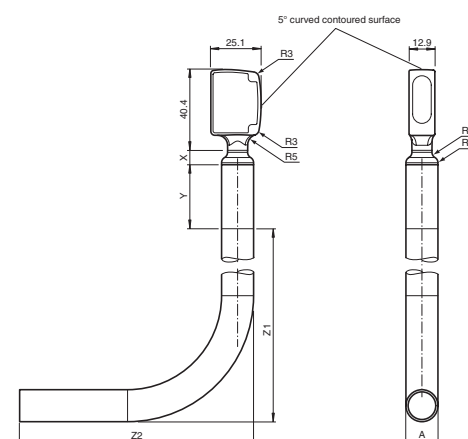

Dimensions	A	X	Y	Z1	Z2
Standard	ø 16	7.2	32	124	116

Anzeigen/Bedienelemente

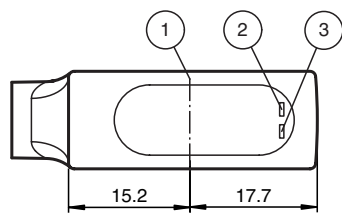

1	optische Achse	
2	Betriebsanzeige	grün
3	Signalanzeige	gelb

If the LED flashes quickly, the object is not reliably detected. The soiling is too extensive or the signal strength is too weak.

Operating mode "II" (contrast detection mode 18%)

Similar to operating mode I.

Operating mode "III" (contrast detection mode 40%)

Similar to operating mode I.

Cleaning:

In the event of impaired reception (soiling), the yellow LED flashes. We recommend cleaning the lens/reflector and checking the cable glands as well as the connectors at regular intervals.

Indicators/operating means

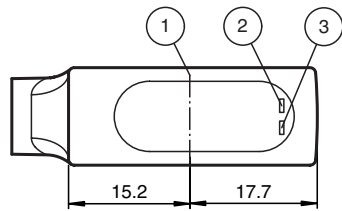

1	Optical axis	
2	Operating display	green
3	Signal display	yellow

Charakteristische Ansprechkurve Courbe de response caractéristique Curve di risposta caratteristica

Characteristic response curve Curva de respuesta característica

Möglicher Abstand (Versatz) zwischen optischer Achse und Referenzobjekt.

Permissible distance (offset) between optical axis and reference target.

Ecart possible entre l'axe optique et la cible de référence.

Desplazamiento entre el eje óptico y objeto de referencia.

Distanza possibile (sfalsato) tra l'asse ottico e l'oggetto di riferimento.

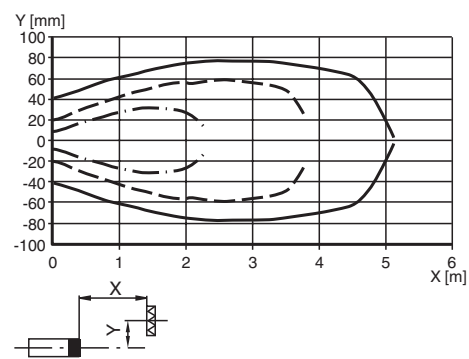

Relative Empfangslichtstärke Intensité relative de la lumière reçue Intensità relativa luce in ricezione

Relative received light strength Potencia relativa de recepción lumínica

Funktionsreserve, Stability control, Réserve de fonctionnement, Reserva de función, Funzione riserva

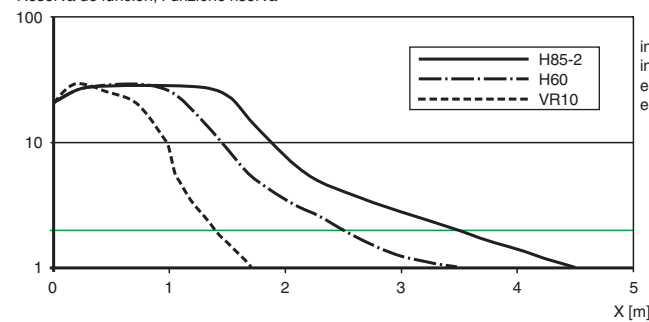

in Kontrast-Stellung "I ... III",
in switch position "I ... III",
en position de l'interrupteur "I ... III",
en posición de conmutación "I ... III"

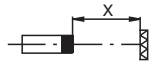

Relative Empfangslichtstärke Intensité relative de la lumière reçue Intensità relativa luce in ricezione

Relative received light strength Potencia relativa de recepción lumínica

Funktionsreserve, Stability control, Réserve de fonctionnement, Reserva de función, Funzione riserva

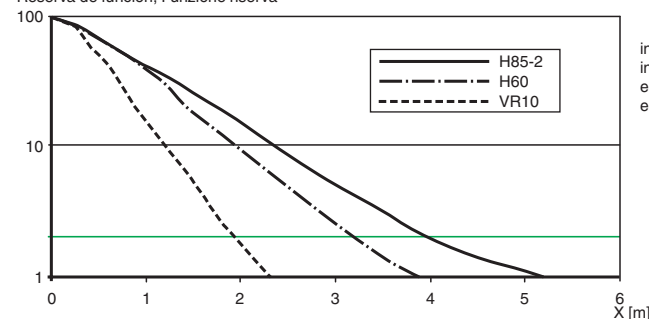

in Kontrast-Stellung "N",
in switch position "N",
en position de l'interrupteur "N",
en posición de conmutación "N"

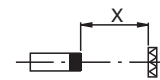

Intended use

Function:

A retro-reflective sensor contains transmitters and receivers integrated in a single housing. The transmitted light is reflected back to the receiver by a reflector. When the light beam is interrupted by an object, the switching function is triggered.

This device is suitable for clear object detection. The reduced signal strength causes increased switching sensitivity.

Mounting instructions:

Flange mounting:

The mounting flange integrated on the sensor offers the option of securing the sensor directly to a machine bed. A corresponding through hole is required to mount the sensor on the machine bed. The mounting flange is sealed against the machine bed by the accompanying seal and secured from below by the washers and nut supplied. The sensor must be aligned with the reflector before being secured in position definitively.

Flange mounting with ball:

The ball integrated in the flange mount allows the sensor to swivel $\sim \pm 30^\circ$.

Pipe mount:

The pipe mount offers the option of fixing the sensors at various heights via clamping devices or screw connections, for example, which are not included with the delivery.

Setup instructions

The green LED behind the front panel lights up when the operating voltage is switched on. The sensor is automatically set to max. sensitivity (default setting) or to the last teach-in setting.

Mount a suitable reflector opposite the sensor.

In operating mode "N", the yellow LED should light up permanently when you direct the light beam towards the reflector.

Operating mode "N" (normal operation):

The yellow LED lights up when light beam is unobstructed.

Place the object to be detected into the beam. When the object is detected, the yellow LED goes out. After removing the target, the LED indicator again lights yellow.

The operating modes and contrast detection settings are selected via the external teach input on the sensor.

Operating mode "I" (contrast detection mode 10%):

The yellow LED lights up permanently when light path is unobstructed. Place the object to be detected into the beam. When the object is identified, the yellow LED goes out.