



exida Certification S.A.  
2 Ch. de Champ-Poury  
CH-1272 Genolier  
Switzerland

Tel.: +41 22 364 14 34  
email: info@exidaCert.ch

## **Results of the IEC 61508 Functional Safety Assessment**

Project:

**KCD2-SR-(Ex)\*(.LB)(.SP) and HiC2821 / HiC2822**

Customer:

**Pepperl+Fuchs GmbH**  
Mannheim  
Germany

Contract No.: P+F 1109-099-C

Report No.: 1109-099-C R026

Version 1, Revision 0, May 2012

Audun Opem, Peter Söderblom

## Management summary

The Functional Safety Assessment of the Pepperl+Fuchs GmbH, performed by *exida* Certification S.A. consisted of the following activities:

- *exida* Certification S.A. assessed the setup of the development process used by Pepperl+Fuchs GmbH for development projects against the relevant requirements of IEC 61508:2000 parts 1 and 2. Special focus was put on the change process and to the adherence to this, as planned by [D101].  
  
Subject to this assessment were the Functional Safety Planning activities, the tailoring of the Verification and Validation activities and the realization of the technical safety aspects using the KCD2-SR-(Ex)\*(.LB)(.SP) and HiC2821 / HiC2822 development project.
- *exida* Certification S.A. audited the results from the detailed audit of the development process, performed during the initial assessment, which investigated the compliance with IEC 61508:2000 of the processes, procedures and techniques as implemented in the Pepperl+Fuchs GmbH KCD2-SR-(Ex)\*(.LB)(.SP) and HiC2821 / HiC2822 development project. The investigation was executed using subsets of the IEC 61508 requirements tailored to the work scope of the development team.
- *exida* Certification S.A. assessed the Safety Case prepared by Pepperl+Fuchs GmbH against the technical requirements of IEC 61508:2000.



The above stated assessment activities were performed via a review of the previous assessment reports with related arguments and the assessment of the activities and documents related to the modification project as specified by the "Impact Analysis for change in devices with functional safety according to IEC 61508 – (.SP)-versions of KCD\*... DDE-2165", [D101.]

The result of the Functional Safety Assessment can be summarized by the following statements:

**The audited development process as tailored and implemented by the Pepperl+Fuchs GmbH Type A KCD2-SR-(Ex)\*(.LB)(.SP) and HiC2821 / HiC2822 development project, complies with the relevant safety management requirements of IEC 61508:2000 SIL 2.**

**The assessment of the FMEDA, which was performed according to IEC 61508, has shown that the KCD2-SR-(Ex)\*(.LB)(.SP) and HiC2821 / HiC2822 have a PFH / PFD<sub>AVG</sub> within the allowed range for SIL 2 (HFT = 0) according to table 2 of IEC 61508-1 and a Safe Failure Fraction (SFF) of > 81%.**

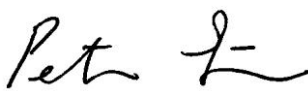
**This means that the KCD2-SR-(Ex)\*(.LB)(.SP) with Hardware version 05-4282B and HiC282\* with hardware version 05-4283A are capable for use in SIL 2 applications in low and high demand mode, when properly designed into a Safety Instrumented Function per the requirements in the Safety Manual.**

		
Assessor Audun Opem	Assessor Peter Söderblom	Review Dipl.-Ing. (FH) Peter Müller

## Content

Management summary.....	2
1 Purpose and Scope .....	4
1.1 Tools and Methods used for the assessment. ....	4
2 Project Description.....	5
2.1 Description of the Functional Safety Management System .....	5
2.2 Description of the System .....	5
3 Project management.....	7
3.1 Assessment of the development process.....	7
3.2 Roles of the parties involved .....	8
4 Results of the Functional Safety Assessment .....	9
4.1 Technical aspects of the KCD2-SR-(Ex)*(.LB)(.SP) and HiC2821 / HiC2822 .....	9
4.2 Functional Safety Management.....	11
4.2.1 Safety Life Cycle .....	11
4.2.2 FSM planning.....	11
4.2.3 Documentation.....	12
4.2.4 Training and competence recording .....	12
4.2.5 Configuration Management .....	12
4.3 Safety Requirement Specification .....	12
4.3.1 Safety Requirement Specification and traceability into design.....	12
4.4 Change and modification management.....	12
4.4.1 Change and modification procedure.....	13
4.5 Hardware Design .....	13
4.5.1 Hardware architecture design.....	13
4.5.2 Hardware Design / Probabilistic properties.....	14
4.6 Verification & Validation .....	15
4.6.1 HW related V&V activities .....	15
4.7 Safety Manual.....	16
4.7.1 Operation, installation and maintenance requirements.....	16
5 Agreement for future assessment .....	17
6 Reference documents.....	18
7 Status of the document.....	21
7.1 Releases.....	21

## 1 Purpose and Scope

This document describes the results of the

Full Functional Safety Assessment according to IEC 61508

of the product development processes according to the safety lifecycle phase 9 of IEC 61508-1. The purpose of the assessment was to investigate the compliance of:

- the KCD2-SR-(Ex)\*(LB).(SP) and HiC2821 / HiC2822 with the technical IEC 61508-2 requirements for SIL 2 and the derived product safety property requirements

and

- the KCD2-SR-(Ex)\*(LB).(SP) and HiC2821 / HiC2822 development processes, procedures and techniques as implemented for the safety-related deliveries with the managerial IEC 61508-1 and -2 requirements for SIL 2.

It was not the purpose to assess the fulfillment of the statement of conformance from Pepperl+Fuchs GmbH for the following European Directives;

- EMC Directive
- Pressure Directive
- Low Voltage Directive
- ATEX Directive

The correct execution of all activities that lead to the statement of conformance to these European Directives is in the responsibility of Pepperl+Fuchs GmbH and builds a basis for the certification.

It was not the purpose of the assessment / audits to investigate Company quality management system versus ISO 9001 and ISO 9000-3 respectively.

The assessment has been carried out based on the quality procedures and scope definitions of *exida* Certification S.A.

### 1.1 Tools and Methods used for the assessment.

This assessment was carried out by using the *exida* Certification S.A. assessment documents, templates and checklists which are derived from the Safety Case DB tool. The expectations for a positive judgment of the assessor are documented within this tool.

The assessment was based on a set of document templates, e.g. for the document review and assessment comments.

## 2 Project Description

### 2.1 Description of the Functional Safety Management System

The functional safety management system is implemented by the use of the QM plan [D21], the P+F Development process [D18] and the related planning documents, which describe the activities in detail.

The related planning documents are mainly the Safety Validation Plan [D19], the document plan [D36], the responsibility allocation [D37] and a set of templates and guidelines.

Evidence for the fulfilment of the detailed requirements has been collected in [D18] and [D25], which was subject to the initial assessment.

### 2.2 Description of the System

The devices are available as safe area version (KCD2-SR-\*(.LB)(.SP)) where they can be used as a signal conditioner providing isolation for non-intrinsically safe applications. Also the devices are available as hazardous area version (KCD2-SR-Ex\*(.LB)(.SP), HiC282\*) allowing use as isolated barriers for intrinsic safety applications.

The KC devices are available with screw terminals or spring terminals. The type code of the versions with spring terminals has the extension ".SP".

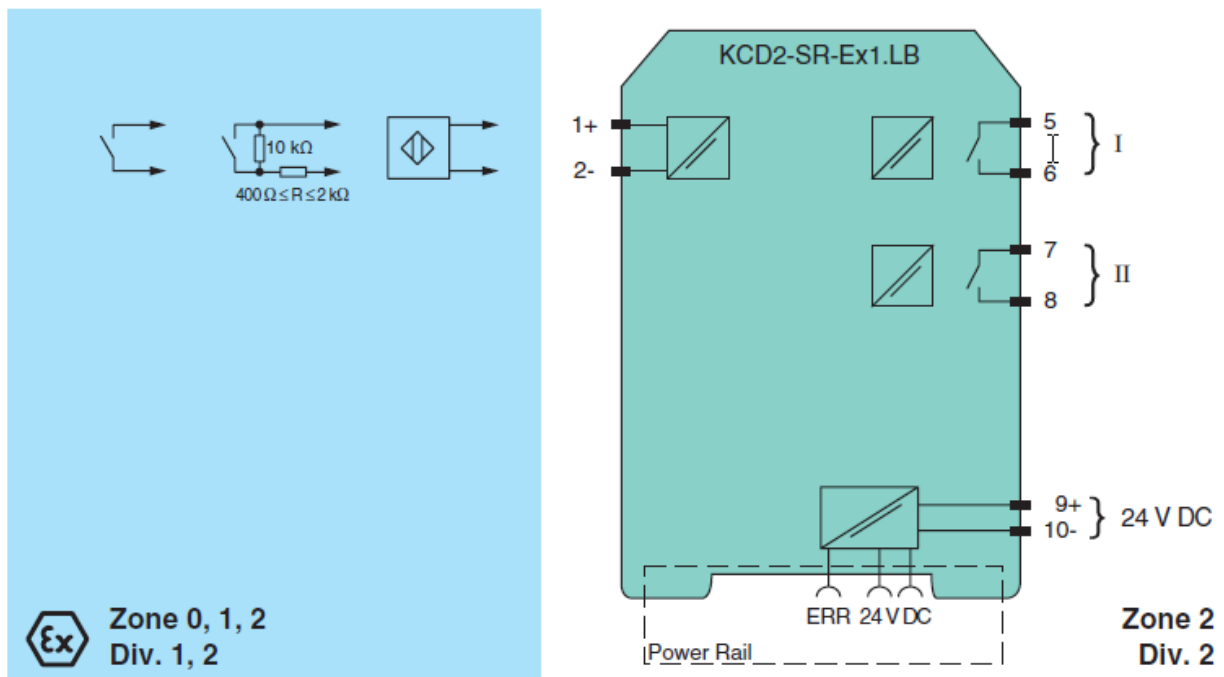

**Figure 1: Block diagram of KCD2-SR-Ex1.LB(.SP)**

Note: The pinout is identical for the non-EX version KCD2-SR-1.LB(.SP).

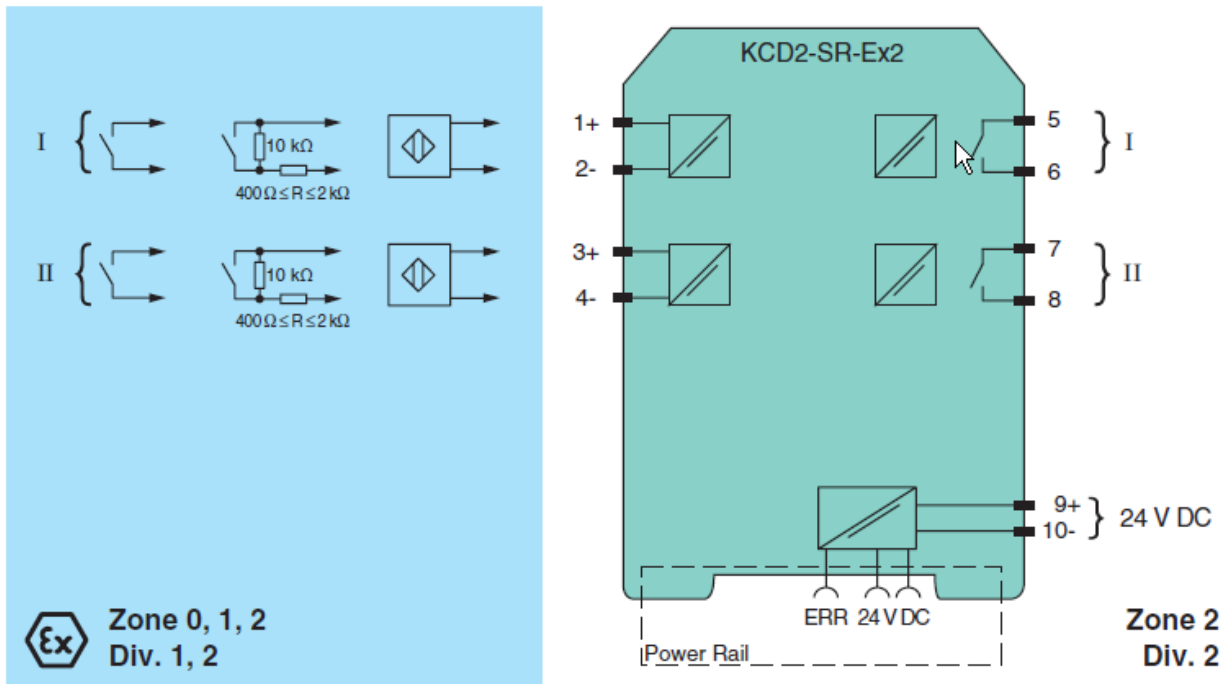

**Figure 2: Block diagram of KCD2-SR-Ex2(.SP)**

Note: The pinout is identical for the non-EX version KCD2-SR-2(.SP).

### 3 Project management

#### 3.1 Assessment of the development process

*exida* Certification S.A. assessed the development process used by Pepperl+Fuchs GmbH for the development project and the modification project against the objectives of IEC 61508 parts 1 and 2 by a review of the previous assessment and by assessment of the modification project as specified by the Impact Analysis [D101].

The assessment was planned by *exida* Certification S.A and agreed with Pepperl+Fuchs GmbH.

The initial assessment did assess the development process used by Pepperl+Fuchs GmbH Mannheim for the development project against the objectives of IEC 61508 parts 1 and 2. The development audit was closely driven by requirements subsets filtered from the IEC 61508 content of the *exida* SafetyCaseDB database. That means that the Functional Safety Management related requirements were taken out of the database and then selected according to the assessment steps carried out before (IEC 61508 Objectives and Document reviews).

The following IEC 61508 objectives were subject to detailed auditing at Pepperl+Fuchs GmbH:

- FSM planning, including
  - Safety Life Cycle definition
  - Scope of the FSM activities
  - Documentation
  - Activities and Responsibilities (Training and competence)
  - Configuration management
- Safety Requirement Specification
- Change and modification management
- Hardware architecture design - process, techniques and documentation
- Hardware design / probabilistic
- Hardware and system related V&V activities including documentation, verification
  - Integration and fault insertion test strategy
- System Validation
- Hardware-related operation, installation and maintenance requirements

The project teams, not individuals were audited.

The development audit of the KCD2-SR-(Ex)\*.LB and the HiC2821 / HiC2822 project was performed in Mannheim July 31<sup>st</sup> and August 1<sup>st</sup>, 2006.

The independent review of the initial assessment and update of the report for the KCD2-SR-(Ex)\*(.LB)(.SP) and HiC2821 / HiC2822 according to the changes as specified by the Impact Analysis [D101] was performed by *exida* Certification S.A. 07-08-Feb-2012.

### 3.2 Roles of the parties involved

#### Pepperl+Fuchs GmbH

Represents the designer of the safety related KCD2-SR-(Ex)\*(LB)(.SP) and HiC2821 / HiC2822 and the investigated organization. The following teams / responsible persons were audited:

- Project Management
- Safety Manager
- Validation and Verification

#### *exida* Certification S.A.

As this assessment is based on the already successfully performed assessment [R7], special focus was put on the change process and to the adherence to this as planned by the Impact Analysis [D101]. The activities were done by *exida* Certification S.A. as an independent organization. The assessment was performed by Audun Opem and Peter Söderblom who were not involved in the execution of the audited activities.



## 4 Results of the Functional Safety Assessment

*exida* Certification S.A. assessed the development process used by Pepperl+Fuchs GmbH for this development project against the objectives of IEC 61508 parts 1 and 2 by spot inspections of the previous assessment and by assessment of the modification project. The result of the review is documented in [A1].

All objectives have been successfully considered in the Pepperl+Fuchs GmbH development processes for the KCD2-SR-(Ex)\*(.LB).(SP) and HiC2821 / HiC2822 development.

*exida* Certification S.A. assessed the safety case prepared by Pepperl+Fuchs GmbH, including a set of documents, against the functional safety management requirements of IEC 61508. This was done by a review of the completeness of the related requirements through the arguments presented in the previous assessment, and then a spot inspection of certain requirements related to the modification.

The safety case demonstrated the fulfillment of the functional safety management requirements of IEC 61508-1 and 2.

The detailed development audit [R7] and [A2] investigated the compliance with IEC 61508 of the processes, procedures and techniques as implemented for the Pepperl+Fuchs GmbH KCD2-SR-(Ex)\*(.LB).(SP) and HiC2821 / HiC2822 development project and modification project.

The investigation was executed using subsets of the IEC 61508 requirements tailored to the work scope of the development team.

The result of the assessment shows that the KCD2-SR-(Ex)\*(.LB).(SP) and HiC2821 / HiC2822 with Hardware version 05-4282B and 05-4283A are capable for use in SIL 2 applications, when properly designed into a Safety Instrumented Function per the requirements in the Safety Manual.

Some areas of improvement were nevertheless identified. The recommended improvements given are generally required to formally show the compliance to IEC 61508. However, Pepperl+Fuchs GmbH was able to demonstrate with respect to the size of the project (limited number of people) and the specific complexity of the product that the objectives of the related areas have been successfully met. More details can be found in the chapter below.

### 4.1 Technical aspects of the KCD2-SR-(Ex)\*(.LB).(SP) and HiC2821 / HiC2822

The devices KCD2-SR-\*(.LB).(SP) can be used as interface between Namur sensors / mechanical contacts in the field and digital inputs, e.g. of a PLC. The devices KCD2-SR-Ex\*(.LB).(SP) and HiC2821 / HiC2822 can additionally be used as isolated barriers between hazardous area and safe area.

On the KCD2-SR-(Ex)\*(.LB).(SP), the mode of operation can be configured by switch S1/S2 (two channel unit) or only S1 (one channel unit). The results given in this report are meant for S1/S2 (two channel unit) or only S1 (single channel unit) in position I which is considered to be the normal mode of operation and S1/S2 (two channel unit) or only S1 (single channel unit) in position II which is considered to be the inverse mode of operation.

On the HiC2821, the mode of operation can be configured by DIP switch SW1 – 1 and on the HiC2822 by DIP switches SW1 – 1 and SW1 – 3. When a switch is in ON position, the corresponding channel is in inverse mode of operation while in OFF position the normal mode of operation is given.

The safe state is a de-energized output(s).

This is a single channel Type A (HFT=0) system with low complexity and with built-in Short Circuit and Open Loop detection in HW.

The line fault detection is mandatory when the particular output is used as a part of a safety instrumented function. On the KCD2-SR-(Ex)\*(.LB)(.SC) this is reached by switching S3/S4 to position I on the two channel devices and S3 to position I on the one channel devices. On the HiC2821 devices this is reached by switching SW1 – 3 to ON position. On the HiC2822 devices this is reached by switching SW1 – 3 and SW1 – 4 to ON position.

The two channels of KCD2-SR-(Ex)\*(.LB)(.SP) and HiC2821 / HiC2822 are not intended to be used in a single safety instrumented function, e.g. to increase the hardware fault tolerance as they are not independent.

## 4.2 Functional Safety Management.

### Objectives of the Functional Safety Management

The main objectives of the related IEC 61508 requirements are to:

- Structure, in a systematic manner, the phases in the overall safety lifecycle that shall be considered in order to achieve the required functional safety of the E/E/PE safety-related systems.
- Structure, in a systematic manner, the phases in the E/E/PES safety lifecycle that shall be considered in order to achieve the required functional safety of the E/E/PE safety-related systems.
- Specify the management and technical activities during the overall, E/E/PES and software safety lifecycle phases which are necessary for the achievement of the required functional safety of the E/E/PE safety-related systems.
- Specify the responsibilities of the persons, departments and organizations responsible for each overall, E/E/PES and software safety lifecycle phase or for activities within each phase.
- Specify the necessary information to be documented in order that the management of functional safety, verification and the functional safety assessment activities can be effectively performed.
- Document all information relevant to the functional safety of the E/E/PE safety-related systems throughout the E/E/PES safety lifecycle.
- Document key information relevant to the functional safety of the E/E/PE safety-related systems throughout the overall safety lifecycle.
- Select a suitable set of tools, for the required safety integrity level, over the whole safety lifecycle which assists verification, validation, assessment and modification.

#### 4.2.1 Safety Life Cycle

The development process as described in the P+F Development process [D18] and in the QM Plan [D21] is structured such that all relevant phases of the overall Safety Life Cycle are identified and that different phases are defined with the necessary activities, inputs and outputs.

**Conclusion:** The objectives of the standard are fulfilled by the Pepperl+Fuchs GmbH functional safety management system.

#### 4.2.2 FSM planning

The P+F Development process [D18] together with QM Plan [D21] defines for all the different work steps the required input and output documents. Phases are sorted in the subchapters of the plan. Document [D37] defines the different roles and responsibilities of the development team members.

**Conclusion:** The objectives of the standard are fulfilled by the Pepperl+Fuchs GmbH functional safety management system.

### 4.2.3 Documentation

A set of templates and guidelines which controls the common layout of documents together with basic properties as document name or number, revision and approval identification exists and is part of the normal quality system of Pepperl+Fuchs GmbH.

**Conclusion:** The objectives of the standard are fulfilled by the Pepperl+Fuchs GmbH functional safety management system.

### 4.2.4 Training and competence recording

The different training courses / seminars that were part of the competence record of each individual for the Pepperl+Fuchs GmbH Mannheim project (see [D40]) was documented in a separate record which were maintained and stored by each project member.

**Conclusion:** The objectives of the standard are fulfilled by the Pepperl+Fuchs GmbH functional safety management system.

### 4.2.5 Configuration Management

All version information is stored in the EDM system. Previous releases can always be retrieved. Newer versions get a new index of the same document number.

**Conclusion:** The objectives of the standard are fulfilled by the Pepperl+Fuchs GmbH functional safety management system.

## 4.3 Safety Requirement Specification

### Objectives of the Safety Requirement Specification

The main objective of the related IEC 61508 requirements is to:

- Specify the requirements for each E/E/PE safety-related system, in terms of the required safety functions and the required safety integrity, in order to achieve the required functional safety.

#### 4.3.1 Safety Requirement Specification and traceability into design

The Safety Requirement Specification [D16] is written in Microsoft Word.

The limited size of the system allows for tracking of the requirements even though no specific method is implemented for requirements tracking except tracking of the safety requirements in the validation tests. This is supported by the limited number / size of the applicable documents.

**Conclusion:** The objectives of the standard are fulfilled by the Pepperl+Fuchs GmbH functional safety management system.

## 4.4 Change and modification management

### Objectives of change and modification management

The main objective of the related IEC 61508 requirements is to:

- Ensure that the required safety integrity is maintained after corrections, enhancements or adaptations to the E/E/PE safety-related systems.

#### **4.4.1 Change and modification procedure**

A modification procedure is defined in section 1.3 of the FSM-Plan [D18]. In addition the Pepperl+Fuchs process description describes in section P02.05.2.1 the required steps for carrying out a modification.

A procedure which is used after release exists [D34]. The defined modification procedure in combination with the generic development model is in accordance to the objectives of IEC 61508.

A minor change of the products during the re-assessment was documented in an Impact Analysis [D101] as agreed in later safety projects. This Impact Analysis addresses all relevant aspect of a change, i.e. reason for change, description, safety relevance, affected documents and applicable verification steps including testing. This Impact Analysis is then used as a V&V Plan for the change project.

**Conclusion:** The objectives of the standard are fulfilled by the Pepperl+Fuchs GmbH functional safety management system.

## **4.5 Hardware Design**

### **Objectives of hardware design**

The main objectives of the related IEC 61508 requirements are to:

- Create E/E/PE safety-related systems conforming to the specification for the E/E/PES safety requirements (comprising the specification for the E/E/PES safety functions requirements and the specification for the E/E/PES safety integrity requirements).
- Ensure that the design and implementation of the E/E/PE safety-related systems meets the specified safety functions and safety integrity requirements.

### **Objectives of hardware design / probabilistic properties**

The main objective of the related IEC 61508 requirements is to:

- Ensure that the design and implementation of the E/E/PE safety-related systems meets the specified safety functions and safety integrity requirements.

#### **4.5.1 Hardware architecture design**

The system and hardware architectures are specified in the documents [D38] and [D39]. The hardware design follows the rules of modularization, the use of well known components and de-rating.

**Conclusion:** The objectives of the standard are fulfilled by the Pepperl+Fuchs GmbH functional safety management system.

#### 4.5.2 Hardware Design / Probabilistic properties

As required by IEC 61508 FMEDA, probabilistic calculations have been carried out for the isolated switch amplifiers KCD2-SR-(Ex)\*(.LB).(SP) and HiC2821 / HiC2822; [R1], [R2] and [R3]. The assumptions of the FMEDA are confirmed by a documented Fault Insertion Test [D31].

**Conclusion:** The objectives of the standard are fulfilled by the Pepperl+Fuchs GmbH functional safety management system.

##### 4.5.2.1 KCD2-SR-(Ex)\*(.LB).(SP) and HiC2821 / HiC2822 – with one relay output

The Safe Failure Fraction was confirmed additionally by the Fault insertion tests. The PFD<sub>AVG</sub> listed below shows SIL 2 capability.

**Table 1 Failure rates according to IEC 61508**

$\lambda_s^1$	$\lambda_{dd}$	$\lambda_{du}$	SFF
189 FIT	18 FIT	47 FIT	81,55%

**Table 2 PFD<sub>AVG</sub> values**

	T[Proof] = 1 year	T[Proof] = 2 years
PFH = 4,68E-08	PFD <sub>AVG</sub> = 2,05E-04	PFD <sub>AVG</sub> = 4,10E-04

##### 4.5.2.2 KCD2-SR-(Ex)\*(.LB).(SP) and HiC2821 / HiC2822 – with two relay output in series

The Safe Failure Fraction was confirmed additionally by the Fault insertion tests. The PFD<sub>AVG</sub> listed below shows SIL 2 capability.

**Table 3 Failure rates according to IEC 61508**

$\lambda_s^1$	$\lambda_{dd}$	$\lambda_{du}$	SFF
216 FIT	48 FIT	45 FIT	85,40%

**Table 4 PFD<sub>AVG</sub> values**

	T[Proof] = 1 year	T[Proof] = 2 years	T[Proof] = 5 years
PFH = 4,51E-08	PFD <sub>AVG</sub> = 1,97E-04	PFD <sub>AVG</sub> = 3,95E-04	PFD <sub>AVG</sub> = 9,86E-04

<sup>1</sup> Note that the S category includes failures that do not cause a spurious trip

## 4.6 Verification & Validation

### Objectives of HW related verification & validation activities

The main objectives of the related IEC 61508 requirements are to:

- Demonstrate, for each phase of the overall, E/E/PES and software safety lifecycles (by review, analysis and/or tests), that the outputs meet in all respects the objectives and requirements specified for the phase.
- Test and evaluate the outputs of a given phase to ensure correctness and consistency with respect to the products and standards provided as input to that phase.
- Integrate and test the E/E/PE safety-related systems.
- Ensure that the design and implementation of the E/E/PE safety-related systems meets the specified safety functions and safety integrity requirements.
- Plan the validation of the safety of the E/E/PE safety-related systems.
- Validate that the E/E/PE safety-related systems meet, in all respects, the requirements for safety in terms of the required safety functions and the safety integrity.

#### 4.6.1 HW related V&V activities

The P+F Development Process [D18] together with the QM Plan [D21] and the safety validation plan [D19] define the required verification activities related to hardware and system including documentation, verification planning, and integration test and requirements tracking to validation test.

FMEDA, module test, fault insertion tests and validation tests were carried out.

All hardware validation activities are documented (see [D20] to [D33]). All relevant validation tests are linked to the safety requirements stated in the safety requirements specification.

**Conclusion:** The objectives of the standard are fulfilled by the Pepperl+Fuchs GmbH functional safety management system.

## 4.7 Safety Manual

### Objectives of the Safety Manual

The main objective of the related IEC 61508 requirements is to:

- Develop procedures to ensure that the required functional safety of the E/E/PE safety-related systems is maintained during operation and maintenance.

#### 4.7.1 Operation, installation and maintenance requirements

The responsibility of P+F is to provide the end-users with a Safety Manual [D102], with all necessary product information in order to enable a correct and safe engineering of the product in a safety instrumented function. Additionally, the provided information enables the end-user to perform the required verification analysis steps of a safety instrumented function, e.g. SFF, PFD, proof test interval and procedure, etc. The Safety Manual partly also refers the data sheets which are available of the official web-site for details regarding environmental conditions and other approvals of the product.

**Conclusion:** The objectives of the standard are fulfilled by the Pepperl+Fuchs GmbH functional safety management system.



## 5 Agreement for future assessment

Areas of possible improvements have been identified during the assessment. However, these are not assessed to be in contradiction to an overall positive judgment of the subject.

Recommendations have been given by *exida* Certification S.A. to Pepperl+Fuchs GmbH as confidential information for the following lifecycle phases / sub-phases:

- Configuration Management
- Safety requirement specification and traceability into design
- HW related V&V activities

## 6 Reference documents

The services delivered by *exida* Certification S.A. were performed based on the following standards.

N1	IEC 61508-1:1998	Functional Safety of E/E/PES; General requirements
N2	IEC 61508-2:2000	Functional Safety of E/E/PES; Hardware requirements
N3	IEC 61508-3:1998	Functional Safety of E/E/PES; Software requirements

The initial assessment was based on the audit of the following documents as provided by Pepperl+Fuchs GmbH.

D1	017043a.pdf	Circuit diagram "KCD2-SR-Ex1.LB" 01-7043A of 23.11.05
D2	Product No. 185532	Bill of material "KCD2-SR-Ex1.LB"
D3	185532_ger.xml of 17.07.06	Data sheet "KCD2-SR-Ex1.LB"
D4	017038a.pdf	Circuit diagram "KCD2-SR-Ex2" 01-7038A of 23.11.05
D5	Product No. 185533	Bill of material "KCD2-SR-Ex2"
D6	185533_ger.xml of 17.07.06	Data sheet "KCD2-SR-Ex2"
D7	017040b.pdf	Circuit diagram "HiC2821" 01-7040B of 20.04.06
D8	Product No. 185536	Bill of material "HiC2821"
D9	185536_ger.xml of 04.07.06	Data sheet "HiC2821"
D10	017042a.pdf	Circuit diagram "HiC2822" 01-7042A of 24.09.05
D11	Product No. 185537	Bill of material "HiC2822"
D12	185537_ger.xml of 04.07.06	Data sheet "HiC2822"
D13	Version 0 of 05.06.02	P02.05 Produktpflege.pps
D14	Version 0 of 05.04.02	P08.01 Abwicklung von Produktrücklieferungen-0.ppt
D15	12.02.02	P0205010202 NCDRWorkflow.ppt
D16	fs0001a.pdf	Safety Requirements Specification „KCD/HiC–Series Binary Input Modules (BI)” FS-0001A of 14.02.07
D17	fs0004a.pdf	Safety Manual "KCD2-SR-Ex*. (LB) and HiC 2821/2822" FS-0004A of 14.02.07
D18	fs0005a.pdf	P+F development process "KCD2-SR-Ex*. (LB) and HiC 2821/2822" including arguments on the fulfillment of the requirements (FSM-Plan); FS-0005A of 14.02.07
D19	fs0006a.pdf	Safety Validation Plan "KCD2-SR-Ex*. (LB) and HiC 2821/2822" FS-0006A of 14.02.07

D20	fs0007.pdf	Safety Validation Results "KCD2-SR-Ex*. (LB) and HIC 2821/2822" (prototype check); FS-0007 of 14.02.07
D21	fs0008.pdf	QM-Plan for DDE-0513 / 514; FS-0008 of 14.02.07
D22	fs0009.pdf	Safety Validation Results "KCD2-SR-Ex*. (LB) and HIC 2821/2822" (pilot run sample); FS-0009 of 14.02.07
D23	fs00010.pdf	Safety case C-BI against the technical requirements of IEC 61508; FS-0010 of 14.02.07
D24	fs0012.pdf	Safety Validation Results C-BI; FS-0012 of 05.02.07
D25	Table A16-17-18-BI.doc	Fulfilment of the Requirements acc. Tables A16, A17, A18 of IEC 61 508-2; V1 R1 of 19.02.07
D26	PRDE-4858A and PRDE-4804A	Test report electromechanical and environmental
D27	PRDE-4788A and PRDE-4816A	EMC test report
D28	PRDE-5553	Immunity tests according to NE21 (K-series)
D29	PRDE-4359A	Production qualification test (K-series)
D30	PRDE-4360A	Production qualification test (HiC-series)
D31	FMEDA V6 KCD2-SR-Ex1 1mA V1R2 prax norm WR.xls  FMEDA V6 KCD2-SR-Ex1 4mA V1R2 prax inv WR.xls	Results of the fault insertion tests
D32	PRDE-5080A	Results of the thermography (KCD2-SR-EX2 as representative for all 4 devices)
D33	"Reviewprotokoll Product release HiC282_.doc" of 12.02.07 and "Reviewprotokoll Product release KCD2-SR.doc" of 12.02.07	Results of the review of the hardware and the specification
D34	FTM0067.pdf	Impact Analysis template
D35	01 Project Status.zip of 24.10.06	Status (project progress) reports
D36	Document Overview.xls of 12.07.06	Project documentation overview
D37	contact list.xls of 17.02.06	List of roles and responsibilities
D38	Functional Description 1 chan KND2 + HiD.doc of 14.02.07	Functional description (1 channel)
D39	Functional Description 2 chan KND2 + HiD.doc of 14.02.07	Functional description (2 channels)
D40	AW Schulung Training.msg of 28.02.07	Training record
D41	Impact Analyse conformity statement Non-Ex.doc of 04.11.08	Conformity statement about Non-Ex devices

The following documents were additionally provided by Pepperl+Fuchs GmbH for the modification project.

- D101 FS-0002EA-25, dated 02-Feb-2012 Impact Analysis for change in devices with functional safety according to IEC 61508 – (.SP)-versions of KCD\*... DDE-2165
- D102 TDOCT-1595E ENG dated 03/2012 Revised Safety Manual “Switch Amplifier KCD2-SR-(Ex)\*(.LB)(.SP) HiC282\*” for harmonization with later safety projects

The initial assessment, were documented by the following documents / databases.

- R1 FMEDA V6 KCD2-SR-Ex1 4mA V2R0.xls of 14.03.07
- R2 FMEDA V6 KCD2-SR-Ex1 1mA V2R0.xls of 14.03.07
- R3 FMEDA V6 KCD2-SR-Ex1 1mA second serial relay V2R0.xls of 14.03.07
- R4 Assessment Type A devices V1R0.esc of 02.10.06
- R5 AW SIL Assessment C-Serie.msg of 02.10.06
- R6 Informal pre review comments.msg of 03.11.06
- R7 P+F 05-07-10 R027 V2R0 – Results of the IEC 61508 Functional Safety Assessment – Isolated Switch Amplifiers KCD2-SR-(Ex)\*(.LB) and HiC2821 / HiC2822 dated 24-Nov-2008

This assessment was documented by the following documents.

- A1 P+F 1109-099-C R025 Assessment & Review comments V0R2
- A2 P+F 1109-099-C R026 Assessment Report, KCD2-SR-(Ex)\*(.LB)(.SP) and HiC 2821 / HiC 2822 (this document)
- A3 P+F 0905-35R1-C R004 Assessment Recommendations V7R0

## 7 Status of the document

### 7.1 Releases

Version History: V0R1	Initial version 08-Feb-2012. The report is based on the P+F 05-07-10 R027 V2R0 assessment report. Additionally, the report is updated with changes related to the Impact Analysis for change in devices with functional safety according to IEC 61508 – (.SP)-versions of KCD*... DDE-2165
V0R2	Update 10-Feb-2012 after internal review discussions with Peter Söderblom
V0R3	Update 15-Feb-2012 after review by Peter Müller and by P+F GmbH
V1R0	Updated 11-May-2012 after review by P+F GmbH

Author: Audun Opem, Peter Söderblom

Review: V0R1 Peter Söderblom  
V0R2 P+F GmbH and Peter Müller

Release status: Released