

LVL-Z126
LVL-Z127
LVL-Z130
LVL-Z131

G1½, 1½ NPT

- d** Hochdruck-Schiebemuffe
- e** High pressure sliding sleeve
- f** Manchon coulissant haute pression
- es** Manguito deslizante para alta presión
- i** Manicotto scorrevole per impieghi ad alta pressione
- nl** Schuifmof voor toepassing onder druk

d	Inhalt	
	Geräteidentifikation	3
	Montieren	4
	Schaltpunkt verstellen	11
	Technische Daten	14

es	Indice	
	Identificación del equipo	3
	Montaje	4
	Cambio del punto de conmutación	11
	Datos técnicos	14

e	Contents	
	Device identification	3
	Mount	4
	Reset switch point	11
	Technical data	14

i	Indice	
	Identificazione dello strumento	3
	Montaggio	4
	Impostare il punto di intervento	11
	Dati tecnici	14

f	Sommaire	
	Dénomination	3
	Montage	4
	Réglage point de commutation	11
	Caractéristiques techniques	14

nl	Inhoud	
	Instrument-identificatie	3
	Montage	4
	Schakelhoogte verstellen	11
	Technische gegevens	14

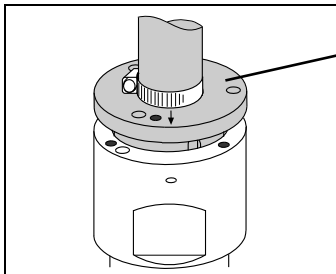

grau = bewegtes Teil
 grey = moved part
 gris = pièce mobile
 gris = parte móvil
 grigio = parte mobile
 grijs = beweegbaar gedeel

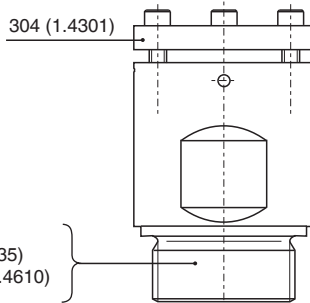

G1½
1½ NPT

316L (1.4435)
Alloy C4 (2.4610)

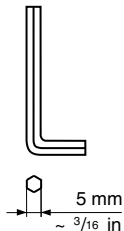
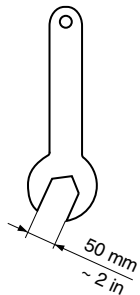

Gabelschlüssel 50
Innensechskantschlüssel 5

Spanner 50
Allen key 5

Clé à fourche de 50
Clé Allen de 5

Llave para tuercas 50
Llave Allen 5

Chiave 50
Brugola 5

Sleutelwijdte 50
Binnen zes-kantsleutel 5

- d** Geräteidentifikation
- e** Device Identification
- f** Dénomination
- es** Identificación del equipo
- i** Identificazione dello strumento
- nl** Instrument-identificatie

- d** Erforderliches Werkzeug
- e** Tools required
- f** Outils requis
- es** Herramientas necesarias
- i** Utensili richiesti
- nl** Benodigd gereedschap

d Montieren
Einschrauben

e Mount
Screw tight

f Monter
Visser

es Montaje
Roscar firmemente

i Montaggio
Avvitare

nl Montage
Inschroeven

G1½
LVL-Z126, 316L (1.4435)
LVL-Z127, Alloy C4

1. Dichtung
Sealing
Joint
Junta
Guarnizione
Dichting

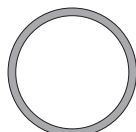

48 mm x 55 mm

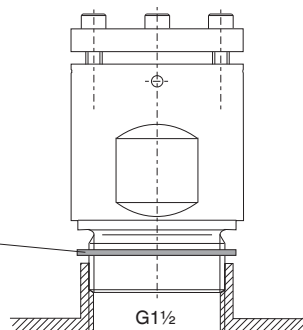

2.

Min. 300 Nm, Max. 600 Nm
(Min. 220 ft lbs, Max. 440 ft lbs)

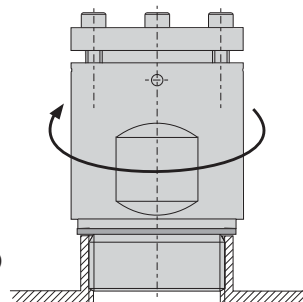

1.

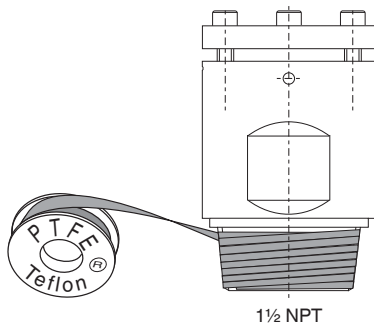

1½ NPT

- d** Einschrauben
- e** Screw tight
- f** Visser
- es** Roscar firmemente
- i** Avvitare
- nl** Inschroeven

2.

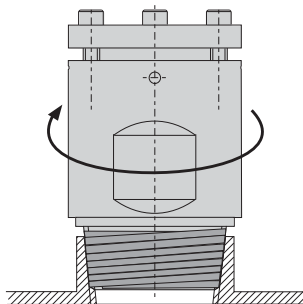

1½ NPT
LVL-Z130, 316L (1.4435)
LVL-Z131, Alloy C4

- d** Oberes Teil abnehmen
- e** Remove top
- f** Enlever la partie supérieure
- es** Retirar la parte superior
- i** Rimuovere la parte superiore
- nl** Bovendeel afnemen

- = Bohrung
= Bore
= Perçage
= Orificio
= Forare
= Boring
- = Gewinde
= Thread
= Filetage
= Paso de tornillo
= Filettare
= Draad

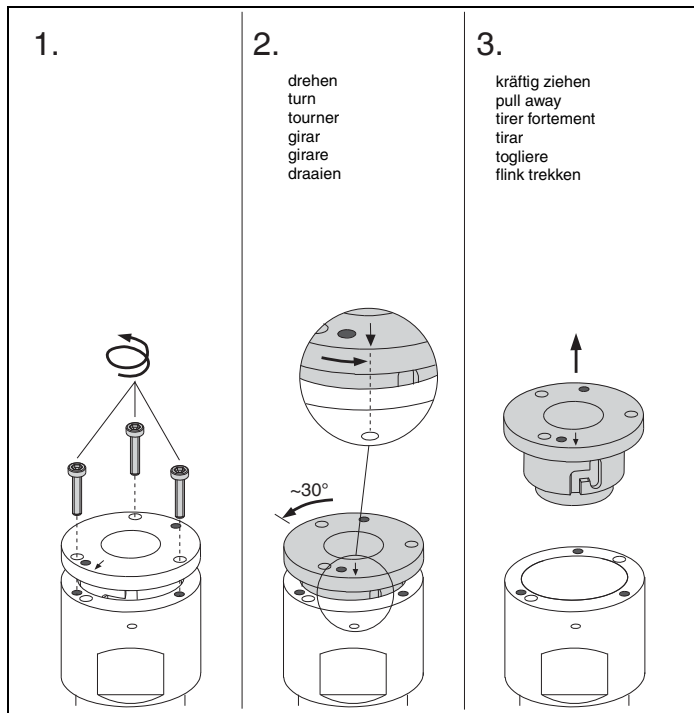

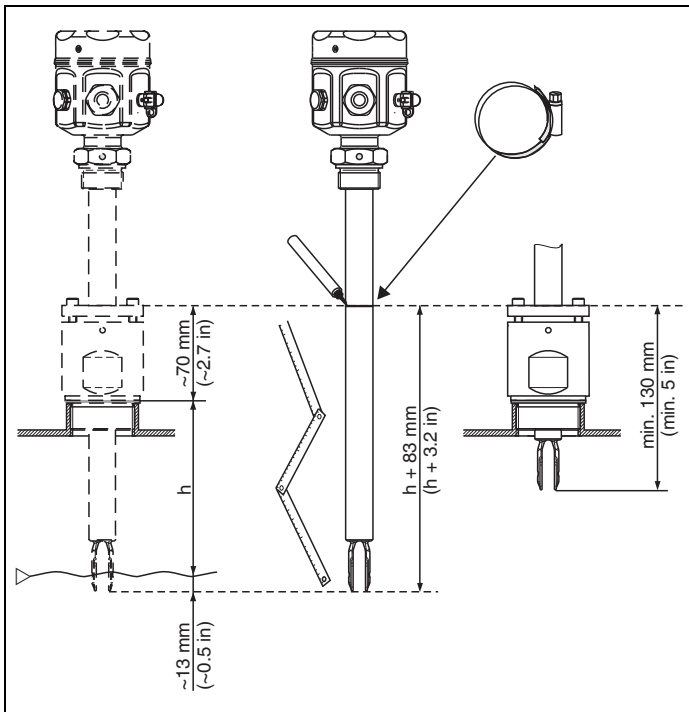

- d** Einstellhöhe markieren oder Anschlag z. B. mit Schlauchschelle
 - e** Mark height or stop, e. g. with hose clip
 - f** Marquer la hauteur de réglage ou butée, par ex. collier
 - es** Marcar altura o stop, ej. abrazadera del tubo
 - i** Segnare l'altezza o fermare, p. e. con una fascetta
 - nl** Instelhoogte markeren of stop, b. v. slangenklem
- ▷ Schaltpunkt
Switchpoint
Point de commutation
Punto de conmutación
Punto di commutazione
Schakelpunt

- d** Oberes Teil aufsetzen,
Vibracon einschieben
- e** Position top,
push in Vibracon
- f** Mettre en place la partie
supérieure, insérer le
Vibracon
- es** Insertar de nuevo la parte
superior, introducir el Vibracon
- i** Riasssemblare,
inserire il Vibracon
- nl** Bovendeel plaatsen,
Vibracon inschuiven

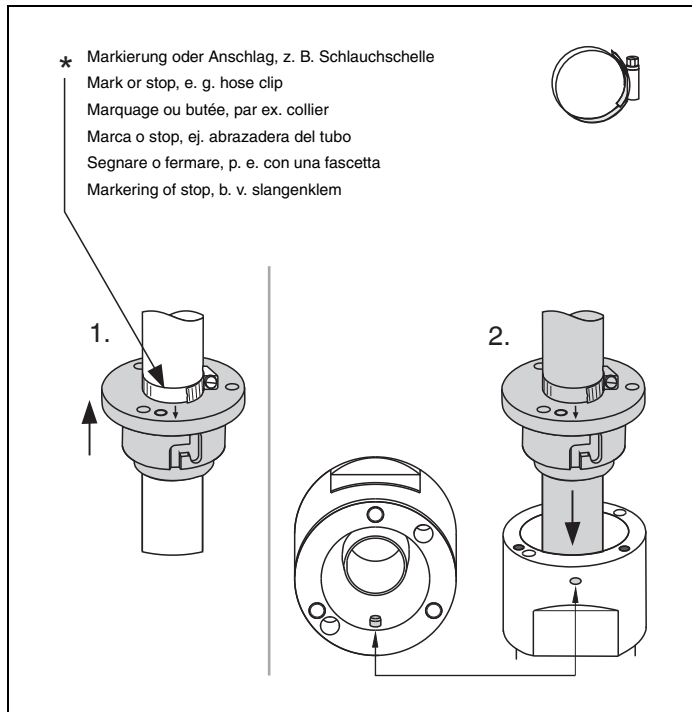

1.

~30°

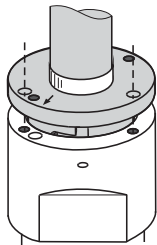

2.

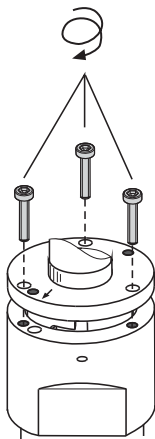

- d** Oberes Teil einrasten
- e** Snap top in place
- f** Encliquer la partie supérieure
- es** Colocar de nuevo la parte superior
- i** Inserire la parte superiore
- nl** Bovendeel positioneren

- d** Oberes Teil festschrauben
- e** Screw top tight
- f** Visser la partie supérieure
- es** Roscar los tornillos firmemente
- i** Avvitare la parte superiore
- nl** Bovendeel vastschroeven

1.

Schrauben festziehen
 tighten screws
 serrer les vis
 apretar tornillos
 avvitare stretto
 schroeven aandraaien

6 Nm ... 8 Nm
 (4.5 ft lbs ... 6 ft lbs)

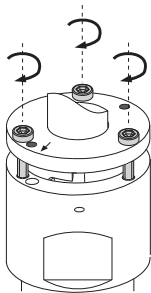

2.

warten
 wait
 attendre
 esperar
 aspettare
 wachten



1 h ... 2 h

3.

Schrauben nachziehen
 tighten again
 resserrer les vis
 reapretar tornillos
 stringere ancora
 schroeven natrekken

6 Nm ... 8 Nm
 (4.5 ft lbs ... 6 ft lbs)

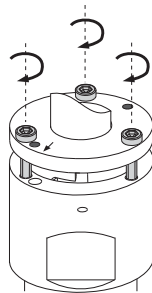

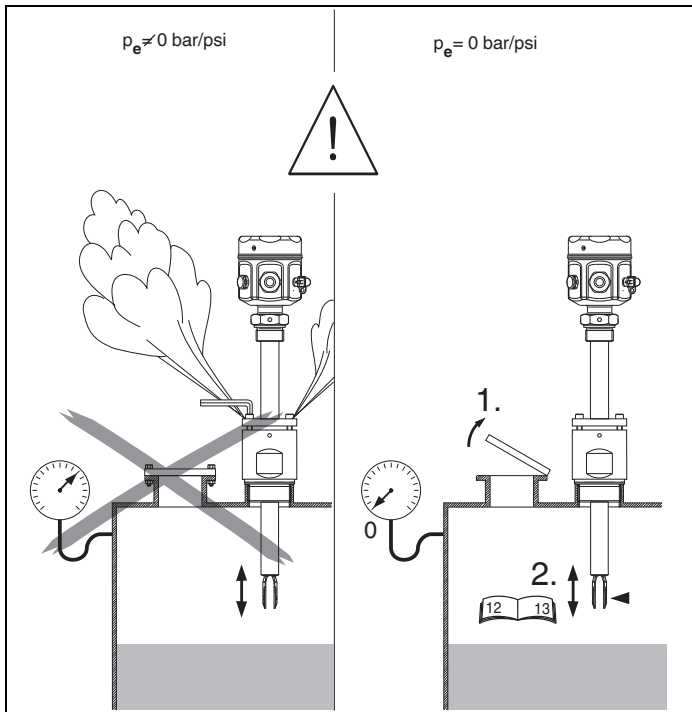

- d** Schalterpunkt verstellen
Behälter **drucklos!!!**
- e** Reset switch point
Tank **not under pressure!!!**
- f** Réglage du point de commutation
Réservoir **sans pression!!!**
- es** Cambio del punto de conmutación
El tanque **no debe estar bajo presión!!!**
- i** Impostare il punto di intervento
Serbatoio **non in pressione!!!**
- nl** Schakelpunt verstellen
Tank **drukloos maken!!!**

- d** Oberes Teil lösen
- e** Remove top
- f** Enlever la partie supérieure
- es** Retirar la parte superior
- i** Rimuovere la parte superiore
- nl** Bovendeel demonteren

- = Bohrung
- = Bore
- = Perçage
- = Orificio
- = Forare
- = Boring
- = Gewinde
- = Thread
- = Filetage
- = Paso de tornillo
- = Filettare
- = Draad

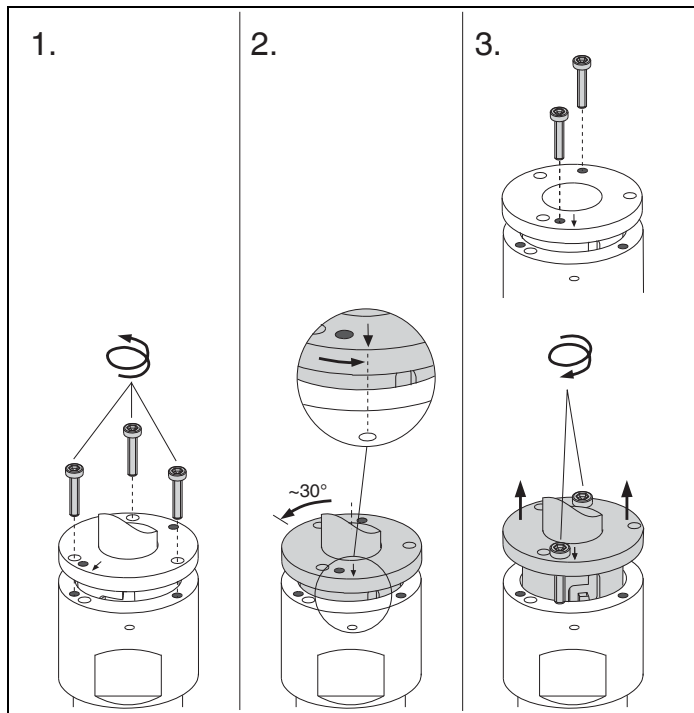

1.

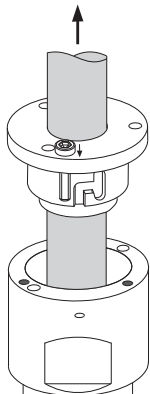

2.

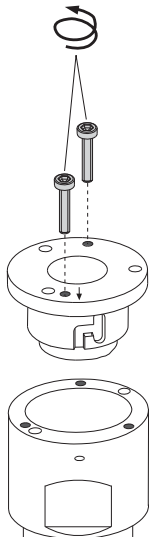

Neue Schaltpunkt-
einstellung
siehe Seiten 7 bis 10

Reset switch point
see pages 7 to 10

Nouveau réglage
point de commutation
voir pages 7 à 10

Cambio del punto
de conmutación
ver pág. 7 a 10

Impostare il punto
di intervento
vds. da pag. 7 a 10

Nieuw schakelpunt
instellen
zie pagina 7 tot 10

d Vibracon herausziehen

e Pull out Vibracon

f Retirer le Vibracon

es Extraer el Vibracon

i Togliere il Vibracon

nl Vibracon uitnemen

d Technische Daten
Abmessungen in mm

e Technical Data
Dimensions in mm

f Caractéristiques techniques
Dimensions en mm

es Datos técnicos
Dimensiones en mm

i Dati tecnici
Dimensioni in mm

nl Technische gegevens
Afmetingen in mm

100 mm = 3.94 in

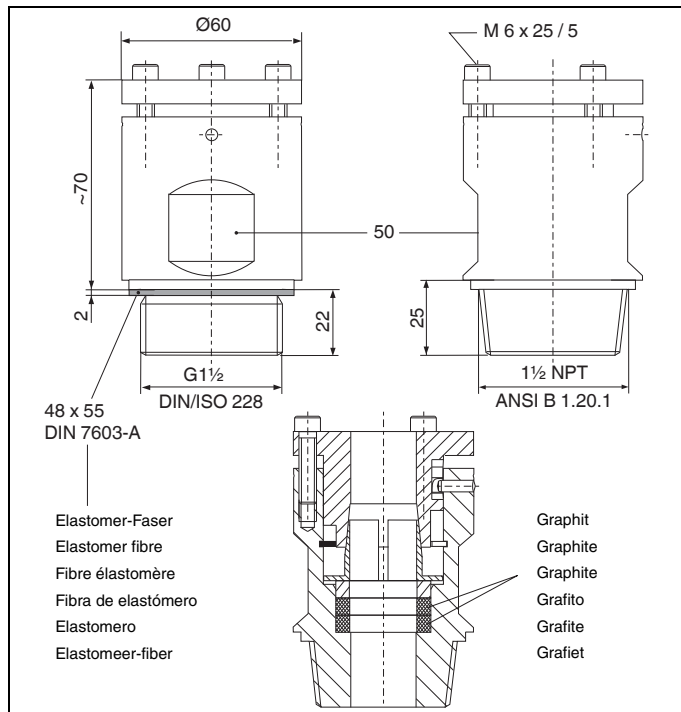

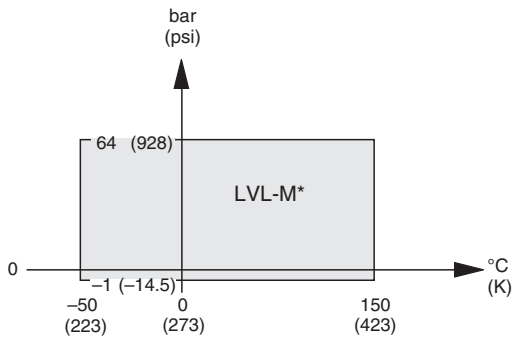

Worldwide Headquarters

Pepperl+Fuchs GmbH
68307 Mannheim · Germany
Tel. +49 621 776-0
E-mail: info@de.pepperl-fuchs.com

USA Headquarters

Pepperl+Fuchs Inc.
Twinsburg, Ohio 44087 · USA
Tel. +1 330 4253555
E-mail: sales@us.pepperl-fuchs.com

Asia Pacific Headquarters

Pepperl+Fuchs Pte Ltd.
Company Registration No. 199003130E
Singapore 139942
Tel. +65 67799091
E-mail: sales@sg.pepperl-fuchs.com

www.pepperl-fuchs.com

Subject to modifications
Copyright PEPPERL+FUCHS • Printed in Germany



52010818

KA154O/98/a6/09.10
FM7.1

PEPPERL+FUCHS
PROTECTING YOUR PROCESS

DOCT-0590B

114664
09/2010