

# PROCESS AUTOMATION

Manual

FD0-VC-Ex4.FF

Valve Coupler  
for Foundation™ Fieldbus



The general terms of delivery for products and services produced or provided by the electrical industry as published by the Zentralverband Elektrotechnik und Elektroindustrie (ZVEI) e.V. in its most recent edition as well as the supplementary proviso: "Extended property proviso" are applicable.

We at Pepperl+Fuchs feel obligated to contribute to the future;  
this publication is, therefore, printed on paper bleached without the use of chlorine.

# Table of Contents

<b>1</b>	<b>SAFETY</b> .....	<b>5</b>
1.1	Scope of the Manual .....	5
1.2	Validity .....	5
1.3	Symbols Used .....	5
1.4	System Operator and Personnel .....	6
1.5	Pertinent Laws, Standards, Directives, and further Documentation .....	6
1.6	Marking .....	6
1.7	Intended Use .....	6
1.8	<b>Mounting and Installation</b> .....	<b>7</b>
1.8.1	General .....	7
1.8.2	Connections .....	7
1.9	<b>Ambient Temperature</b> .....	<b>7</b>
1.10	<b>Repair and Maintenance</b> .....	<b>8</b>
1.11	<b>Delivery, Transport and Storage</b> .....	<b>8</b>
1.12	<b>Disposal</b> .....	<b>8</b>
<b>2</b>	<b>PRODUCT DESCRIPTION</b> .....	<b>9</b>
2.1	<b>Scope of Delivery</b> .....	<b>9</b>
2.2	<b>System Structure</b> .....	<b>9</b>
2.2.1	Device Description .....	9
2.2.2	Connection of Auxiliary Valves .....	10
2.2.3	Connection of Final Position Feedback Contacts .....	11
2.2.4	Description of 2:1 Procedure .....	11
2.3	<b>Accessories</b> .....	<b>12</b>
<b>3</b>	<b>INSTALLATION</b> .....	<b>13</b>
3.1	<b>Assembly</b> .....	<b>13</b>
3.2	<b>Electrical Connection</b> .....	<b>14</b>
3.2.1	General Notes for Connection .....	14
3.2.2	Connection of Fieldbus and DIP Switch Settings .....	15
3.2.3	Connection of Auxiliary Valves and Final Position Feedback Contacts .....	16
3.2.4	EMC, Shielding, Grounding .....	17
<b>4</b>	<b>PARAMETERIZATION AND OPERATION OF THE VALVE COUPLER</b> .....	<b>19</b>
4.1	<b>Introduction</b> .....	<b>19</b>
4.2	<b>Identification, Device ID</b> .....	<b>20</b>
4.3	<b>Interaction of the Transducer Blocks and the DO Function Blocks</b> .....	<b>20</b>
4.4	<b>Interaction of the Transducer Blocks and the DI Function Block</b> .....	<b>21</b>
4.5	<b>Parameterization of Transducer Blocks</b> .....	<b>23</b>
4.5.1	Prerequisite .....	23
4.5.2	Commissioning Procedure .....	23
4.5.3	Drive Design .....	25

Part No.: 108227, Date of issue 15.02.2013

4.5.4	Final Position Feedback .....	25
4.5.5	Target Mode .....	28
4.5.6	Time Monitoring .....	28
4.5.7	Cyclic Functional Test .....	29
4.5.8	Stroke Counter .....	30
4.5.9	Lead Breakage and Lead Short Circuit Monitoring .....	30
4.5.10	Valve and Drive Information .....	31
<b>4.6</b>	<b>Process Information .....</b>	<b>31</b>
4.6.1	Valve Reference Value .....	31
4.6.2	Valve Position .....	31
4.6.3	Breakaway and Transit Times .....	32
<b>4.7</b>	<b>Diagnosis Messages and Alarms .....</b>	<b>32</b>
<b>5</b>	<b>ERROR DETECTION AND TROUBLESHOOTING .....</b>	<b>35</b>
5.1	LEDs .....	35
5.2	Resource Block .....	35
5.3	Transducer Block .....	36
5.4	Function block DO .....	39
5.5	Function Block DI .....	40
5.6	Initialization Run ("Auto Init Command") .....	41
<b>A</b>	<b>TRANSDUCER BLOCK .....</b>	<b>43</b>
<b>B</b>	<b>FUNCTION BLOCKS DO AND DI .....</b>	<b>46</b>
<b>C</b>	<b>RESOURCE BLOCK .....</b>	<b>50</b>
<b>D</b>	<b>GLOSSARY .....</b>	<b>52</b>

# 1 Safety

## 1.1 Scope of the Manual

This manual enables the user to install, start and parameterize the Valve Coupler FD0-VC-Ex4.FF. In addition, it gives information of status/error messages, device safety and monitoring functions, as well as of fault diagnosis and fault elimination.



Note

*Some of the sections of the manual require special knowledge and experience in the field of explosion protection and planning, design, and execution of FOUNDATION Fieldbus systems. No introduction is given in the introduction of FOUNDATION Fieldbus for newcomers or inexperienced users. Users who require additional information should refer to the relevant technical literature, the documentation of the master system used and the publications of Fieldbus Foundation. Many of the terms and abbreviations used in this manual are described in the appendix.*

Section 4 "Parameterization and Operation of the Valve Coupler" focuses on the parameterization of the transducer blocks which include the valve control system and diagnosis functions specific for Pepperl+Fuchs. The representation of the function blocks and the resource block are specific for the control system and documented within the area of the control system. A table of the functions of the DO function blocks, the DI function block and the resource blocks is found in appendices B and C.

FOUNDATION is a trademark (TM) of Fieldbus Foundation.

## 1.2 Validity

The chapter "Safety" is valid as instruction manual.

Specific processes and instructions in this document require special precautions to guarantee the safety of the operating personnel.

## 1.3 Symbols Used

This document contains information that you must read for your own personal safety and to avoid property damage. Depending on the hazard category, the warning signs are displayed in descending order as follows:

### Safety-relevant symbols



Warning

This symbol indicates a warning about a possible danger. In the event the warning is ignored, the consequences may range from personal injury to death or from damage to equipment to destruction.



Attention

This symbol warns of a possible fault. Failure to observe the instructions given in this warning may result in the device and any connected facilities or systems to it develop a fault or fail completely.

### Informative symbols



Note

This symbol brings important information to your attention.

## 1.4 System Operator and Personnel

The plant owner is responsible for its planning, installation, commissioning, operation, maintenance and disassembly.

Mounting, installation, commissioning, operation, maintenance and disassembly of any devices may only be carried out by trained, qualified personnel. The instruction manual must be read and understood.

## 1.5 Pertinent Laws, Standards, Directives, and further Documentation

Laws, standards, or directives applicable to the intended use must be observed. In relation to hazardous areas, Directive 1999/92/EC must be observed.

The corresponding data sheets, declarations of conformity, EC-type-examination certificates, certificates and Control Drawings if applicable (see datasheet) are an integral part of this document. You can find this information under [www.pepperl-fuchs.com](http://www.pepperl-fuchs.com).

Due to constant revisions, documentation is subject to permanent change. Please refer only to the most up-to-date version, which can be found under [www.pepperl-fuchs.com](http://www.pepperl-fuchs.com).

## 1.6 Marking

The following identification is provided on the Valve Coupler FD0-VC-Ex4.FF:

Pepperl+Fuchs GmbH  
D-68307 Mannheim

FD0-VC-Ex4.FF  
CE 0102  
PTB 98 ATEX 2210

 II 2G (1) Ex ia [ia Ga] IIC T4 Gb  
II (1D) [Ex ia Da] IIIC

IECEX TUN 04.0002 Ex ia [ia Ga] IIC T4 Gb  
[Ex ia Da] IIIC  
Ex ic IIC T4 Gc  
[Ex ic Dc] IIIC

## 1.7 Intended Use

The Valve Coupler FD0-VC-Ex4.\*\*\*\* is a field devices for connection to an intrinsically safe FOUNDATION Fieldbus.

The FD0-VC-Ex4.\*\*\*\* is used to operate intrinsically safe low-power auxiliary valves and their final position feedback contacts.

The Valve Coupler FD0-VC-Ex4.\*\*\*\* is used in type of protection II 2G (1) Ex ia [ia Ga] IIC T4 Gb.



*The protection of operators and plant is not ensured, unless the device is used for the purpose intended.*

### 1.8 Mounting and Installation

When using intrinsically safe devices in accordance with IEC/EN 60079-11, follow the EC-type-examination certificate and the national regulations for installations. Reference should be made to IEC/EN 60079-14 for the interconnection of the intrinsically safe circuits. In the Federal Republic of Germany reference should also be made to the "National foreword" to DIN 60079-14/VDE 0165 Part 1.

The Valve Coupler FD0-VC-Ex4.FF is designed for use in potentially explosive atmospheres. The respective maximum values of the field devices and of the Valve Coupler must be considered in the sense of explosion protection (demonstration of intrinsic safety) when interconnecting the intrinsically safe field devices (auxiliary valves, sensors, vibrating forks, etc.) with the intrinsically safe circuits of the Valve Coupler.

The fieldbus connection is a certified, intrinsically safe circuit, in accordance with the FISCO and the Entity model.

When interconnected according to the FISCO model, all the field devices and associated apparatus (fieldbus repeaters) connected to this segment must be certified in accordance with the FISCO model.

#### 1.8.1 General

Mounting, installation, commissioning, operation, maintenance and disassembly of any devices may only be carried out by trained, qualified personnel. The instruction manual must be read and understood.

If devices have already been operated in general electrical systems, they may subsequently no longer be installed in electrical systems used in combination with hazardous areas.

In case the Valve Coupler has been operated in the type of protection "Ex ic", it must not be operated in the type of protection "Ex ia" or "Ex ib" afterwards.

The datasheet containing the electrical data from the EC-type-examination certificate respectively the IECEx Certificate of Conformity and additional technical information is effectively a part of this operating instruction.

#### 1.8.2 Connections

The clamping areas of the Valve Coupler FD0-VC-Ex4.FF are protected by screwed lids.



- 1 Clamping area for connecting field devices
- 2 Clamping area for connecting device to fieldbus
- 3 Protective lid for field device connections
- 4 Protective lid for fieldbus connection

### 1.9 Ambient Temperature

The device may be operated at an ambient temperature ranging from -20 °C ... +70 °C .

### **1.10 Repair and Maintenance**

The devices must not be repaired, changed or manipulated. If there is a defect, the product must always be replaced with an original device.

### **1.11 Delivery, Transport and Storage**

Check the packaging and contents for damage.

Check if you have received every item and if the items received are the ones you ordered.

Keep the original packaging. Always store and transport the device in the original packaging.

Always store the device in a clean and dry environment. The permitted storage temperature (see datasheet) must be considered.

### **1.12 Disposal**

Disposing of devices, packaging material, and possibly contained batteries must be in compliance with the applicable laws and guidelines of the respective country.



## 2 Product Description

### 2.1 Scope of Delivery

Included in the delivery package of the device are:

- A device FD0-VC-Ex4.FF
- One product attachment (instruction manual, datasheet)

The following parts are not included in the delivery package of the device, however, can be requested free of charge up to the number of devices ordered:

- Manual, German and English, incl. data carrier (disk 3,5" or CD) with device description file to integrate the device into the engineering tool



*The manual and the software to integrate the device into the engineering tool is also available at the Pepperl+Fuchs internet homepage [www.pepperl-fuchs.com](http://www.pepperl-fuchs.com).*

Note

*Other accessories see section 2.3 and product catalog of Pepperl+Fuchs.*

### 2.2 System Structure

The Valve Coupler FD0-VC-Ex4.FF is a field device for FOUNDATION Fieldbus according to IEC 61158 and is used to operate a maximum of four intrinsically safe low power auxiliary valves and a maximum of eight final position feedback contacts (PFCs; NAMUR sensors or other mechanical contacts) within areas subject to explosion hazards or areas which are not subject to explosion hazards at the FOUNDATION Fieldbus H1. An auxiliary valve is used as a pilot valve for one actuator which can be provided with final position feedback contacts to feed back the drive position. The term valve as used within the manual means the overall chain consisting of auxiliary valve, control drive and regulation unit.

For the FOUNDATION Fieldbus H1 a shielded twisted two-wire cable is used. Via this two-wire cable the field devices are supplied and data are exchanged. FF-H1 allows branches.

#### 2.2.1 Device Description

The Valve Coupler is accommodated in a housing for panel mounting. This housing may also be mounted at a pipeline using specific accessories. The device has been designed for the type of protection "intrinsic safety" and can be arranged in the field subject to the approval. The connector terminals of the fieldbus are spatially and galvanically separated from those of the auxiliary valves and PFCs. LEDs on top of the terminal blocks indicate the instantaneous status of the Valve Coupler locally.

- PWR (power): green (continuous light) = Supply voltage available
- COM/ERR: red (continuous light) = Hardware fault  
red (flashing) = no bus activity or bus fault
- IN/OUT CHK: red (continuous light) = Fault code for a hardware fault detected during acceleration.  
red (flashing) = Channel fault; for the cause of the fault refer to section 5.

For the wiring and evaluation of the final position feedbacks the 2:1 procedure is used which is described in more detail in section 2.2.4.

Monitoring and diagnosis features are integrated in the field device. The Valve Coupler can record automatically the lead breakages or short-circuits, carry out position dependent functional tests (cyclic function test, section 4.5.7) and count the setting operations of the valve.

Commissioning is done in two steps. In the first step a "configuration wizard" aids during commissioning. After demanding the type of drive used (self-opening or self-closing) the kind of final position feedback contacts (PFCs) and, if time monitoring is activated, the reference values of breakaway and transit times of the valves are taught in automatically by an initialization run. Commissioning can also be done independently from the configuration wizard by direct parameterization.

After this first step the monitoring and diagnosis features mentioned above can be activated optionally in a second step.

A prerequisite to control up to four valves are four independent function blocks (DO type) and transducer blocks, which are itemized in the engineering tool and which must be parameterized individually as described above.

The Valve Coupler corresponds to the profile identification type number 111 and communication profile 31 according to Fieldbus Foundation specification.

Figure 2.1 shows the internal structure of the Valve Coupler and also the galvanic isolation can be seen there.

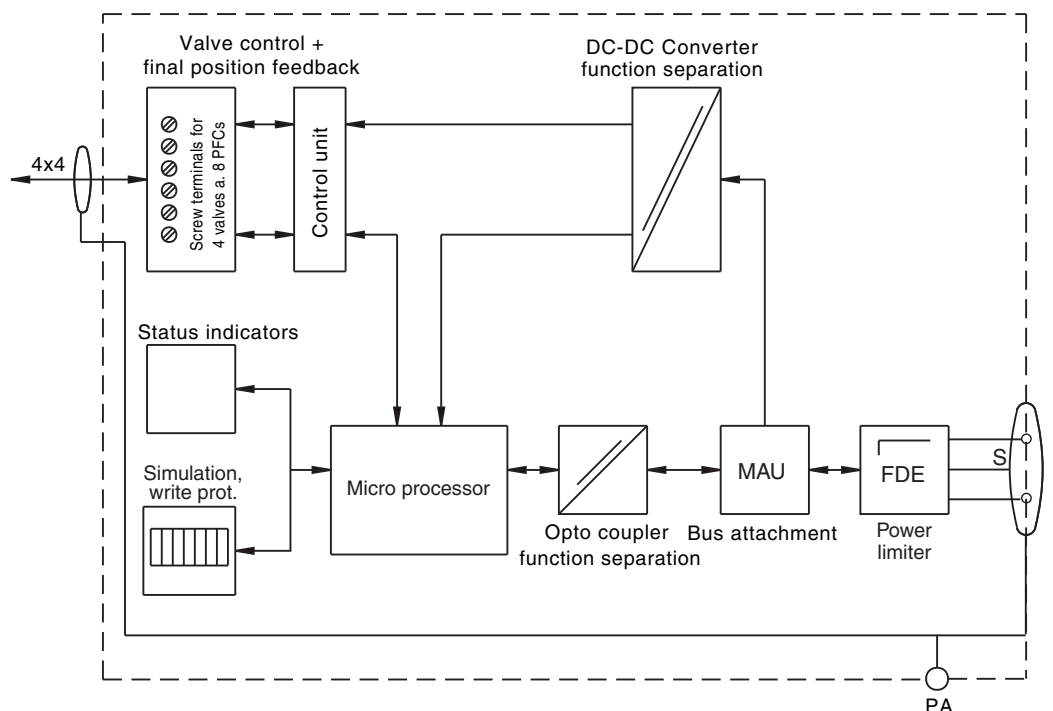

Figure 2.1: Mimic diagram of Valve Coupler FD0-VC-Ex4.FF

## 2.2.2 Connection of Auxiliary Valves

The Valve Coupler FD0-VC-Ex4.FF has been designed particularly for intrinsically safe low-power auxiliary valves in 6 V design, which control the supply of compressed air to the drive.

The following circuit values are applicable (per channel):

$$U_S = 6.4 \text{ V} \dots 7.9 \text{ V}$$

$$I_S = 1.5 \text{ mA (inrush current of the valve)}$$

$$I_{\text{Hold}} = 1.0 \text{ mA (holding current with the valve switched on)}$$



*Do not connect any additional current consumers to the valve circuit (e. g., LEDs). If additional consumers are connected to the valve circuit, successful operation of the Valve Coupler cannot be ensured.*



*The valve control outputs of the Valve Coupler can also be checked for correct functioning without connected valves by simulating the valve by a 3 kΩ resistor. In deactivated state, via this resistor a voltage of approx. 0.3 V and in activated state a voltage of approx. 3 V can be measured. It is not possible to connect a voltmeter direct to the open terminals of the valve output because then a voltage  $U_S$  of 6.8 V... 7.4 V is measured independently of the state.*

To switch it on, the auxiliary valve is triggered with an increase inrush current  $I_S$  for a short period of time. Then it is held in its position at the lower holding current  $I_{\text{hold}}$ .



Note

Suitable valves are offered, among others, by Samson, ASCO /Joucomatic and Herion. For information of suitable valve types, please refer to the datasheet and Internet and to Pepperl+Fuchs.

### 2.2.3 Connection of Final Position Feedback Contacts

Two final position feedback contacts per valve can be used for detecting the valve positions. These may be NAMUR proximity sensors or mechanical switches. The binary signals of both PFCs are requested alternately from the valve trigger equipment in the 2:1 procedure via a pair of cores and must thus be suitable for this procedure or be provided with a polarized diode (see section 2.2.4).

### 2.2.4 Description of 2:1 Procedure

The 2:1 procedure allows to transfer two independent binary signals to a pair of cores without bus system. To do so, the two sensors or mechanical contacts are triggered and evaluated in time multiplex mode anti-parallel (see figure 2.2).

A prerequisite of this procedure is that the sensors/mechanical contacts are provided with a polarized diode and one of the two sensors/mechanical contacts is operated in polarized mode. When using NAMUR sensors from Pepperl+Fuchs as PFCs these polarized diodes are integrated. The connection is described in section 3.2.3.

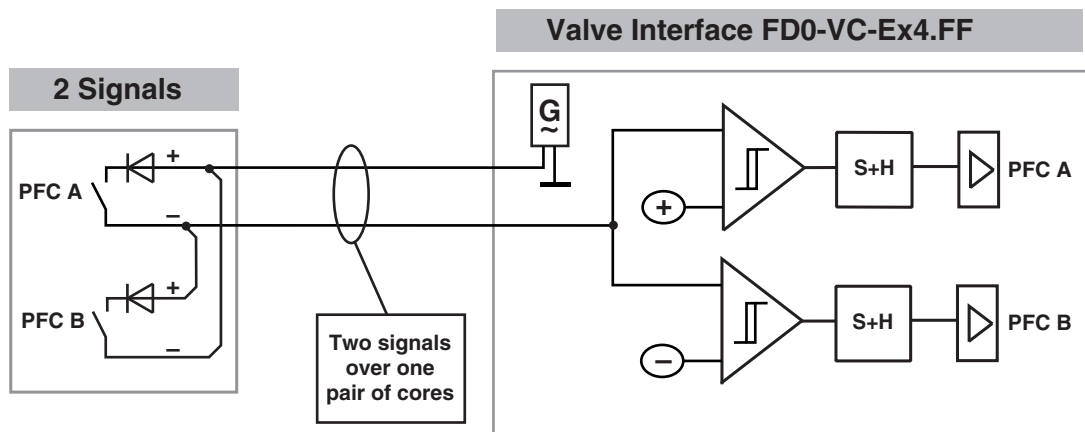

Figure 2.2: Principle of operation of the 2:1 procedure for proximity switches



Attention

Due to the time multiplex mode, not all NAMUR proximity switches can be operated. A selection of suitable NAMUR sensors from Pepperl+Fuchs that also have an integrated polarized diode, is given in the following list. For other suitable sensors, please refer to the datasheet. If sensors not listed in the datasheet are to be used, please contact Pepperl+Fuchs to clarify whether these can be used together with the Valve Coupler.

## Fieldbus Valve Coupler FD0-VC-Ex4.FF Product Description

NCB1,5-6,5M25-N0(-V1)	NJ 0,8-5GM-N
NCB1,5-8GM25-N0(-V1)	NJ 1,5-6,5-N
NCB2-12GM35-N0(-V1)	NJ1,5-8GM-N(-V1)
NCB2-F1-N0	NJ 2-12GK-N
NCB5-18GM40-N0(-V1)	NJ 2-12GM-N(-V5)
NCN3-F24L-N4	NJ 2-V3-N(-V5)
NCN3-F24R-N4	NJ 3-18GK-S1N
NCN3-F25F-N4-V1	NJ 5-11-N(-G)
NCN3-F25-N4-V1	SC2-N0
NCN3-F31-N4-K(-V1/-V16/-V18)	SC3,5-N0
NCN4-12GM35-N0(-V1)	SJ 2-N
NCN8-18GM40-N0(-V1)	SJ 3,5-G-N
NJ 0,8-4,5N	SJ 3,5-N

### 2.3 Accessories

The following accessories are available for the Valve Coupler:

<i>Pipe clip mounting set F-TMC</i>	<i>Order no.: 104930</i>
<i>Socket wrench SW19 for cable glands PG9</i>	<i>Available from: Hugro Armaturen GmbH Rudolf-Blessing-Str. 5 D-79183 Waldkirch Germany  Hugro ref. no. 784.19</i>

### 3 Installation

#### 3.1 Assembly

The housing of the Valve Coupler with the degree of protection IP65 is provided for wall mounting. It is fixed by means of two screws (maximum thread diameter 6 mm, see figure 3.1). The right through bore-hole is provided with a grounding plate, so that the grounding of the device can be directly achieved by the fixing screw if a suitable mounting place has been chosen.

 *When grounding the device via the fixing screw, ensure low-resistance connection with ground. Otherwise ground via a separate grounding cable.*

**Note** *The mounting set F-TMC is available as accessory for pipe installation (see section 2.3).*

The place of installation should be well accessible for

- mounting
- electrical installation and cable routing
- the six device LEDs should be visible for quick fault diagnosis
- setting of simulation and hardware write protection switches.

 *In narrow spaces it may be convenient to make the electrical connections prior to the mounting of the device, also because the PG9 cable glands for the valve connection are arranged very close to each other and there may be insufficient space for using an open-end wrench.*

**Note** *An SW 19 socket wrench is available as installation accessory for the Valve Coupler to facilitate screwing/unscrewing of the PG9 cable glands (see section 2.3).*



*To keep the degree of protection IP65 of the housing, make sure when doing connection work that unused cable glands are provided with the supplied blank inserts and that these cable glands are tightened to seal.*

#### Mechanical dimensions

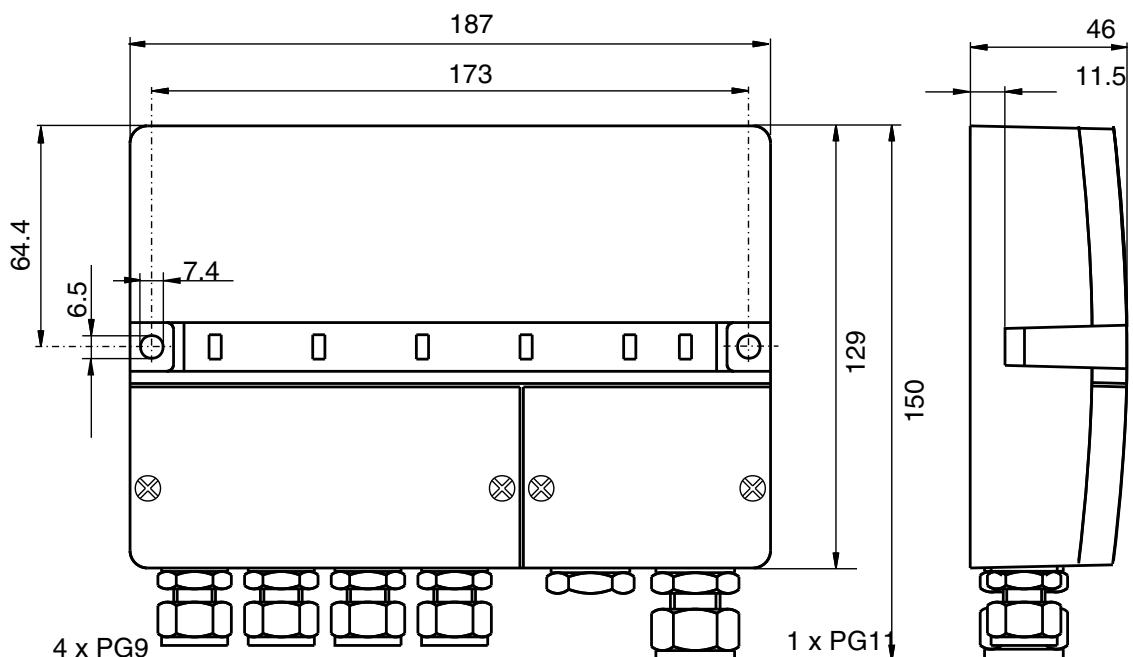

Figure 3.1: Mechanical dimensions of the Valve Coupler FD0-VC-Ex4.FF

## 3.2 Electrical Connection

### 3.2.1 General Notes for Connection



Work at live installations and electrical connections must be carried out by appropriately trained specialists only.

Warning

If the Valve Coupler is connected with an activated live bus segment make sure that the bus cables are not short-circuited so that the function of other bus stations is not affected.

### Location of Electrical Connections

The connector terminals of the Valve Coupler for the connection of the valves with PFCs and the fieldbus are accommodated in two separate terminal spaces.



Figure 3.2: Valve Coupler with the terminal space covers removed



To keep the degree of protection IP65 of the housing, ensure the following when doing connection work:

- For connection, only round cables are used with the diameter of 4 mm ... 8 mm for the valves and 5 mm ... 10 mm for fieldbus
- The cable glands are tightened properly according to the cable used ( approximate value 3.75 Nm cable gland, cap nut 2.5 Nm)
- The sealings of the terminal space cover are not damaged and the screws of the terminal space cover are tightened properly with the torque of 1.5 Nm
- Unused cable glands must be closed by the supplied blank inserts and these cable glands are tightened in a sealing way

## 3.2.2 Connection of Fieldbus and DIP Switch Settings

The following illustration shows the location and designation of the connector terminals for the bus connection and the DIP switches to switch on and off simulation and write protection.

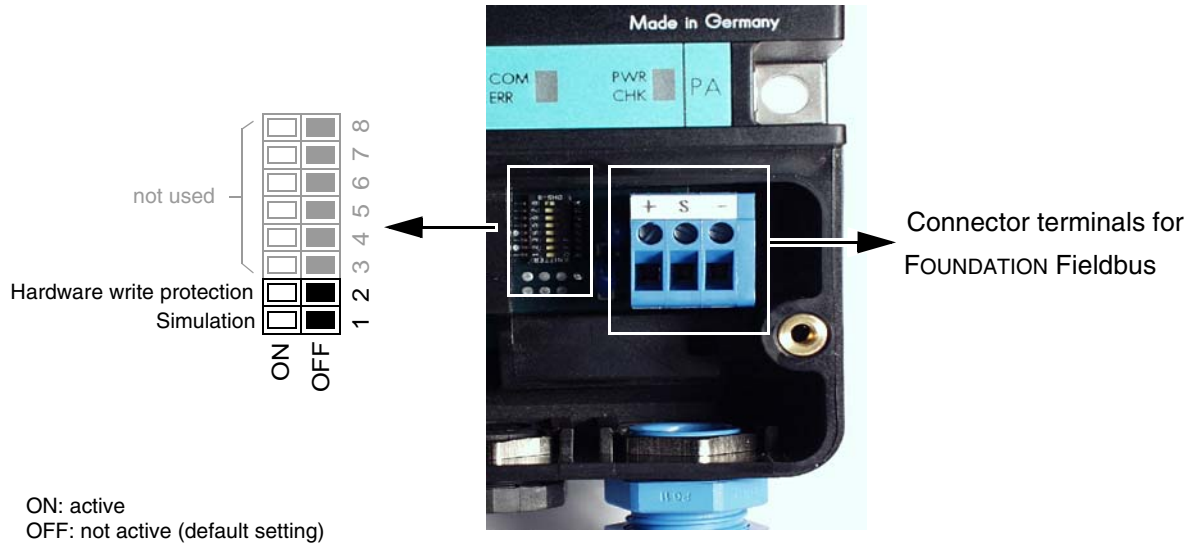

Figure 3.3: Location and designation of the connector terminals for bus connection

### Terminal assignment

Terminal	Signal	Explanation
+	FF-H1 +	Fieldbus FF bus cable +
S	Shield	Shield of bus cable
-	FF-H1 -	Fieldbus FF bus cable -

### DIP switch settings

- Switch 1: Simulation ON/OFF  
 With activated simulation (simulation setting ON) the valve position transferred from the transducer block to the function block can be set by the control system independent from the actual valve position.
- Switch 2: Hardware write protection ON/OFF  
 Parameterization of the device via the bus is no longer possible when write protection is activated (setting ON).
- Switch 3 ... 8: not used

### 3.2.3 Connection of Auxiliary Valves and Final Position Feedback Contacts

The following illustration shows the location and designation of the terminals for valve connection and PFCs.



Figure 3.4: Location and designation of the connector terminals for the valve connection incl. final position feedback contacts

#### Terminal assignment

Terminal	Signal	Explanation
1	Valve 1 +	Output, trigger signal for valve 1
2	Valve 1 -	
3	PFC 1A +, PFC 1B -	2 inputs, signals of 2 PFCs from valve 1, transfer by 2:1 procedure
4	PFC 1A -, PFC 1B +	
5	Valve 2 +	Output, trigger signal for valve 2
6	Valve 2 -	
7	PFC 2A +, PFC 2B -	2 inputs, signals of 2 PFCs from valve 2, transfer by 2:1 procedure
8	PFC 2A -, PFC 2B +	
9	Valve 3 +	Output, trigger signal for valve 3
10	Valve 3 -	
11	PFC 3A +, PFC 3B -	2 inputs, signals of 2 PFCs from valve 3, transfer by 2:1 procedure
12	PFC 3A -, PFC 3B +	
13	Valve 4 +	Output, trigger signal for valve 4
14	Valve 4 -	
15	PFC 4A +, PFC 4B -	2 inputs, signals of 2 PFCs from valve 4, transfer by 2:1 procedure
16	PFC 4A -, PFC 4B +	
PA	Equipotential bonding	Connection for equipotential bonding and/or connection for the shield between the Valve Coupler and valve and PFC. Preferably <b>no</b> shielded cable should be used here

As described in section 2.2.4, the PFCs are used in the 2:1 procedure. For the connection of sensors or mechanical contacts the possible connections are shown in figure 3.5; terminals 3 and 4 are given as examples.



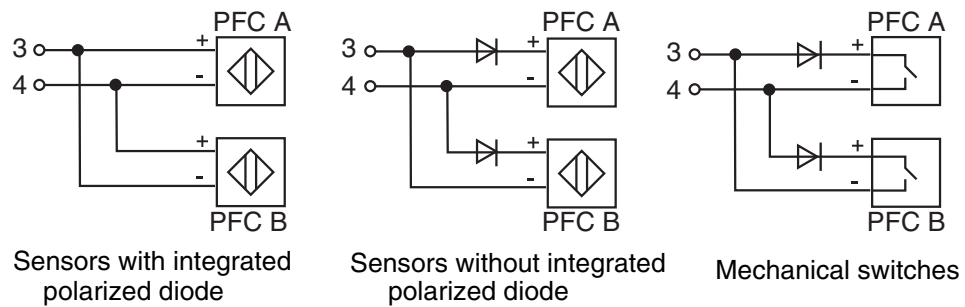

Figure 3.5: Connection of PFCs and additional polarized diodes



*To use mechanical contacts as valve final position feedbacks, use a "Field Terminal Block" from Pepperl+Fuchs or two polarized diodes to be able to make use of the 2:1 procedure.*



**Note**

*If mechanical contacts are used as valve final position feedbacks, also the lead breakage and short circuit monitoring system can be used after adding an additional serial and parallel resistor in the lead.*

*The following is required:*

*one 1 kΩ series resistance (for monitoring short circuit),*

*one 10 kΩ parallel resistance (for lead-breakage monitoring).*

### 3.2.4 EMC, Shielding, Grounding

Cables are shielded to exclude electro-magnetical interference.

The device is provided with an equipotential bonding terminal (PA) which is connected with the grounding plate of the right housing mounting bore inside the device. Preferably, the device should be grounded directly via the grounding plate during installation (see note in section 3.1). Large metallic objects with a proper galvanic earth connection are suitable, e.g., switch cabinets, tower shelf columns, etc.

Connect the shield of the bus cable to the terminal (S) of the Valve Coupler.

Preferably do not use shielded cables for the connecting leads between the Valve Coupler and the valve and PFC.



**Note**

*When using a double-shielded bus cable, e.g., wire braided and metallized foil, connect both shields with each other low-resistively at the line end when preparing the cables.*

*Power supply cables generate quite a number of interferences, e.g., inrush current of a three-phase electric motor. Thus avoid parallel routing of supply cables and data/signal cables in the same cable duct.*



## 4 Parameterization and Operation of the Valve Coupler

### 4.1 Introduction

The valve function blockcoupler FD0-VC-Ex4.FF includes, as any other FOUNDATION Fieldbus device, a resource block and several transducer blocks and function blocks. Figure 4.1 shows the blocks contained in the Valve Coupler.

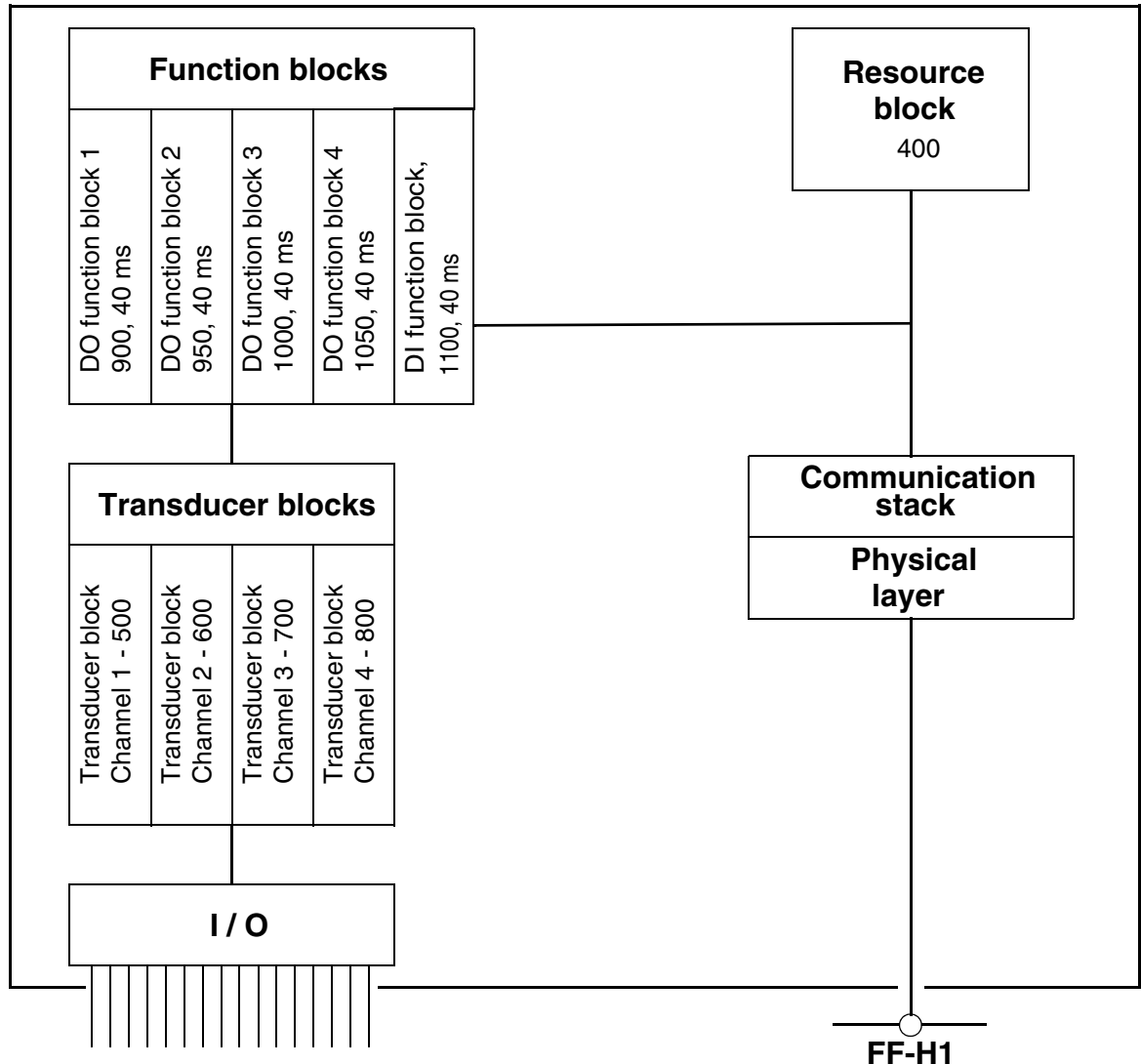

Figure 4.1: Block diagram of Valve Coupler

In addition to the "communication stack" which organizes the data exchange between the fieldbus and the application, and a resource block which describes the characteristics of the whole device, there are one DO function block and a transducer block each per channel.

The four DO function blocks correspond to the specification of Fieldbus Foundation and can be used individually to establish a FOUNDATION Fieldbus application. A reference value is specified here for the valve position and the current valve position is fed back. The reference value for the valve position is transferred to one of the transducer blocks which then control the valve and read back the current position via the PFCs. In addition, several diagnosis and monitoring functions for the valve can be activated in the transducer blocks.

This chapter is focused on the commissioning of the transducer blocks and their interaction with the function blocks and the resource block.

Representation and commissioning of the function blocks and resource block are specific to the control system and documented there in detail. The annex includes a list and explanation of all parameters of the three types of block.

The DI function block complies with the Foundation Fieldbus specification. Using the DI function block, all eight PFC sensor values can be read at the same time and be processed in a function block application.

### 4.2 Identification, Device ID

Each FOUNDATION Fieldbus device has an unequivocal device ID. This device ID is structured as follows for the Valve Coupler FD0-VC-Ex4.FF:

Manufacturer Type		Serial number
502B46	0001	021400564026

The manufacturer identification "502B46" is for the Pepperl+Fuchs GmbH, the type "0001" identifies the Valve Coupler. These three fields are the same for all Valve Couplers FD0-VC-Ex4.FF.

A differentiation can be made via the serial number if several Valve Couplers are connected to one FF-H1 segment. The serial number is provided on a label at the right side of the device.

### 4.3 Interaction of the Transducer Blocks and the DO Function Blocks

In each of the DO function blocks, a reference value is calculated for the valve position in the parameter OUT\_D which is transferred to the transducer block which is connected with the function block. The connection between a function block and a transducer block is made via the parameter "Channel" of the function block. The channel number (1 ... 4) of the transducer block is entered in this parameter with which the function block shall interact.

OUT\_D of the function block can assume values from 0 to 255. The value "0" means valve "closed", values unequal to zero mean valve "open". Such a specified reference value is contrary to many conventional devices where the number "0" means "valve current OFF" and "1" means "valve current ON". The reference value is taken over by the transducer block only if the status is "good (C)" or "Good (NC)". However, if the status is "uncertain" or "bad", the auxiliary valve is not controlled electrically and the drive moves into the mechanical safety position.

If the current position of the valve is determined via two PFCs, the transducer block transfers the current position back to the DO function block. The function block represents the transferred value in the parameter READBACK\_D. The numerical value depends on the parameterization of the transducer block (see section 4.5.4).

This relation is illustrated by figure 4.2.



Note

*In addition to the reference value for the valve position and the current valve position, also diagnosis information is transferred between the function block and the transducer block. Thus, it is possible to receive diagnosis messages from the transducer block also with control systems which do not support alarms of transducer blocks. More detailed information in that connection can be found in section 4.7*



Note

*The parameter READBACK\_D is shown at the parameter PV\_D within the DO function block. If the IO option "invert" is activated in the function block, the numerical value is inverted. I. e., a value of "0" becomes "1", a value unequal to zero becomes "0". If the current valve position shall be transferred in cycles to a control system or used in a function block application, the value of PV\_D can be transferred to BKCAL\_OUT\_D via the IO option "PV for BKCal\_Out". If this option is not activated the value of BKCAL\_OUT\_D is only a copy of the current reference value.*

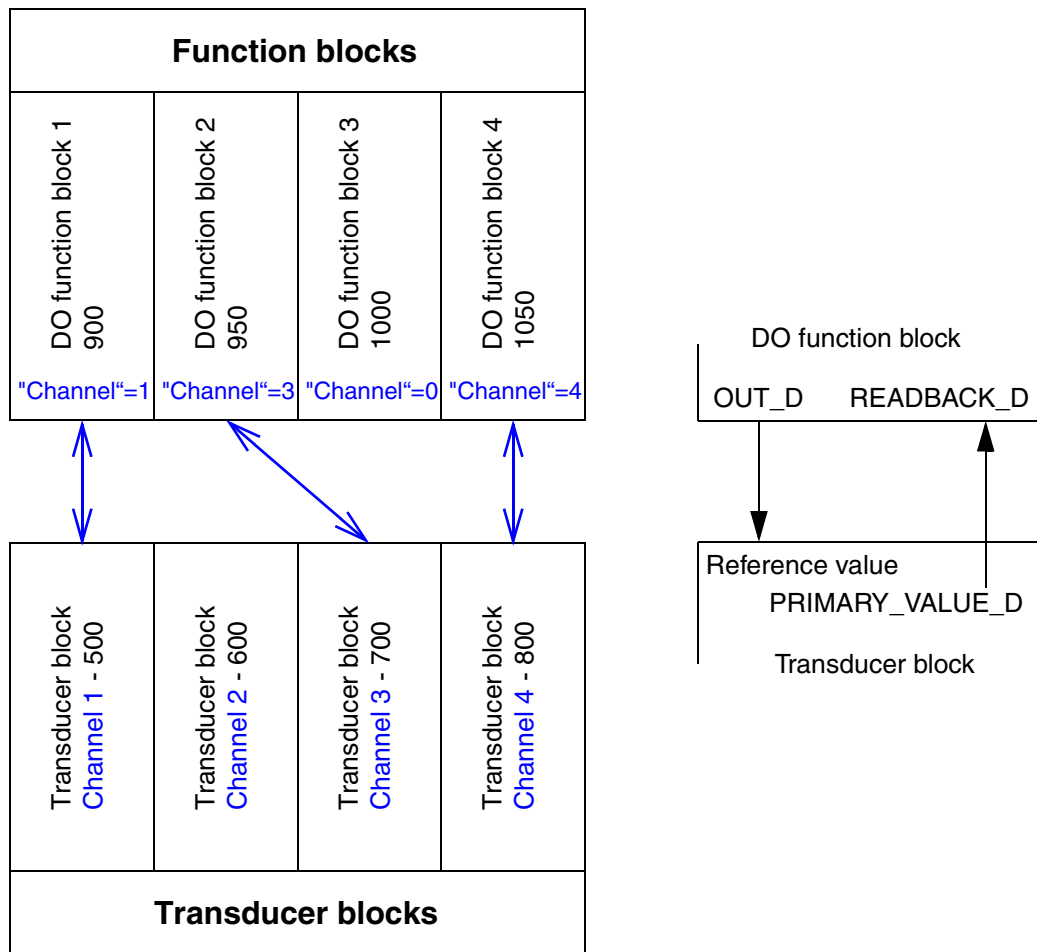
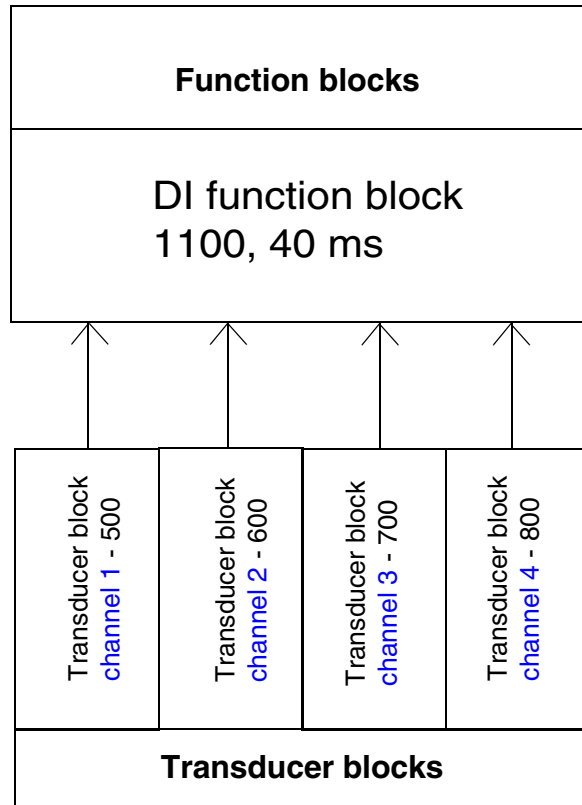

Figure 4.2: Interface of DO function block/transducer block

#### 4.4 Interaction of the Transducer Blocks and the DI Function Block

The DI function block can be used to read all eight PFCs, independent of the DO function blocks. To this end, the parameter "CHANNEL" has to be assigned the value five. This establishes a connection to the transducer blocks 1 to 4, which can be used to read out the PFC sensor values of the channels 1 to 4. These values are then assigned to the respective bits of the parameter value "FIELD\_VAL\_D" according to the following table:

Bit	Description
0	PFC sensor value A of channel 1
1	PFC sensor value B of channel 1
2	PFC sensor value A of channel 2
3	PFC sensor value B of channel 2
4	PFC sensor value A of channel 3
5	PFC sensor value B of channel 3
6	PFC sensor value A of channel 4
7	PFC sensor value B of channel 4



Within the DI function block, the value of the parameter "FIELD\_VAL\_D" is assigned to the parameter "PV\_D" and from there to the parameter value of "OUT\_D". Thus cyclic transmission of all eight PFC sensor values to a DCS is possible as well as making further use of them in a function block application.



Attention

*Because of the many inputs mapped to a single parameter the status does not reflect the status of a specific input any more. So failures as lead breakage or short circuit of the sensor wires are no longer signaled using the status. The status will be always "Good". Only hardware failures of the VC device will be shown as a status of "Bad - Device Failure".*



Note

*Using the parameter PV\_FTIME, you can determine for how long (in seconds) the PFC sensor values have to be stable before they are passed on from the parameter FIELD\_VSL\_D to the parameter PV\_D.*

*Depending on the application used, PFC sensor values can keep changing and/or influence one another. In such a case, an inappropriate numeric value can result in the parameter PV\_D not being updated at all.*

*This is why Pepperl+Fuchs recommends setting the parameter PV\_FTIME to 0.*



Note

*If time monitoring is not necessary, Pepperl+Fuchs recommends setting the parameter "Sensor usage" to "Use sensor values for PV\_D".*

## 4.5 Parameterization of Transducer Blocks

### 4.5.1 Prerequisite

To parameterize the Valve Coupler FD0-VC-Ex4.FF the associated device description (DD) must be included in the engineering tool used. Unless integration has been made by the manufacturer of the control system, you will find the necessary files on the enclosed data carrier and in Internet under [www.pepperl-fuchs.com](http://www.pepperl-fuchs.com).

How to import the device description into the control system is described in the operating manual of the latter. In general, the files are stored under a fixed directory in the sub-directory 502B46\0001 during import.



Note

*An extended integration exists for some control systems. The associated files can also be found on the enclosed data carrier and in Internet under [www.pepperl-fuchs.com](http://www.pepperl-fuchs.com).*

### 4.5.2 Commissioning Procedure

A transducer block is parameterized in two steps as shown in figure 4.3.

During the first step, mainly the valve used and the connected PFCs are described by setting parameters. In addition to manual parameterization, this can also be done by means of a "setup wizard". This assistant, in dialog with the user, carries out the parameterization of the drive design "Actuator Fail Action" (section 4.5.3) and then determines the value for the parameter "Sensor usage" automatically during an initialization run (section 4.5.4).



Warning

*During this initialization run the valve is opened and closed once. Make sure not to endanger persons and avoid dangerous tampering with the plant process.*

In addition it is possible to activate the monitoring of the breakaway and running times of the valve by means of the "setup wizard" (section 4.5.6). If this is the case, the current breakaway and running times of the valve are determined during the initialization run and taken over as reference values. The maximum permitted deviation is set to 30 %.

On completion of the first step fix the "target mode" of the transducer block (see section 4.5.5). Please note that the parameter "PV\_D generation" can be modified in the second step of parameterization only in "Out of Service OOS" mode.



Note

*The "setup wizard" is executed in the device description as a method. How to start this method is described in the documentation of the control system.*

*For the use of the "setup wizard" we recommend also to read the procedure for manual configuration.*

During the second step of parameterization, the valve position information transferred to the function block can be adapted to the requirements (PV\_D generation, section 4.5.4), and the following diagnosis options can be activated:

- Lead interruption and/or short circuit monitoring for the valve lead (section 4.5.9)
- Lead interruption and/or short circuit monitoring for the PFC lead (section 4.5.9)
- Cyclic functional test for the position "open" and/or "closed" (section 4.5.7)
- Stroke counter and limit value (section 4.5.8)

# Fieldbus Valve Coupler FD0-VC-Ex4.FF Parameterization and Operation of the Valve Coupler

The alarms which are released by the different diagnostic options are described in section 4.7. Then the information can be stored in the Valve Coupler via the connected valve and the connected drive. After having set all parameters, check that no "configuration error" is displayed in the parameter "BLOCK\_ERR" of the parameterized transducer block. For the measures to be initiated in such a case refer to section 5.3.



*During commissioning, tests for proper functioning can be carried out by setting the DO function block in the "man" mode and specifying the reference value for the valve position directly via OUT\_D.*

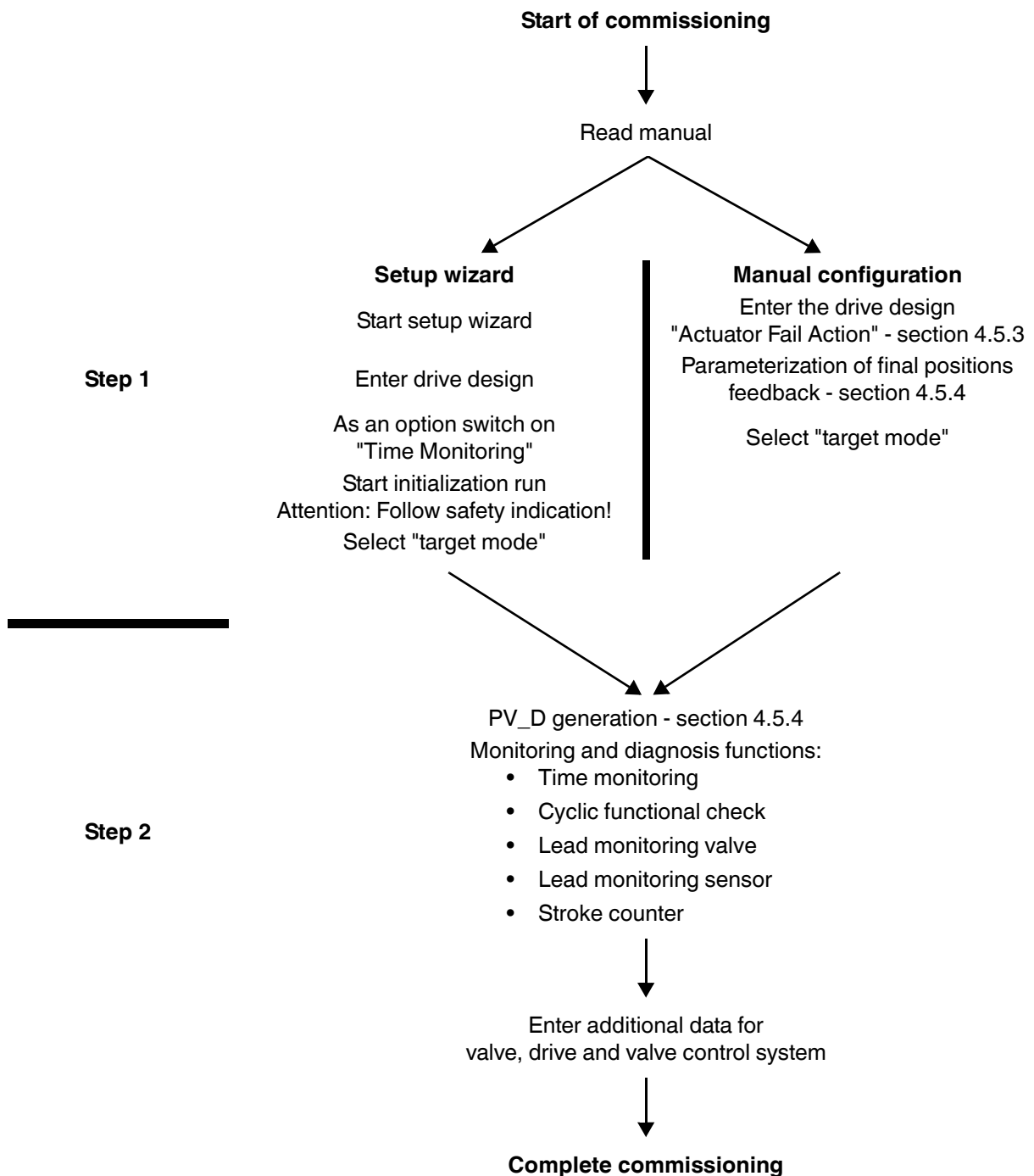

Figure 4.3: Procedure for commissioning



## 4.5.3 Drive Design



Note

*For subsequently setting the parameter "Actuator Fail Action", the "target mode" of the transducer block must be set to "Out of Service (OOS)" as it is possible only here to make a modification.*

### Drive Design "Actuator Fail Action"

The Valve Coupler supports the two most frequent drive designs "self-opening" and "self-closing". For the definition of these two terms the drive and the control valve must be considered a unit. The terms "self-opening" and "self-closing" designate the behavior of the drive when setting the electrical control system to "0", irrespective of the behavior of the drive during a failure of the auxiliary power. The following values can be set:

- Undefined
- Self-opening
- Self-closing

The value "undefined" has been set at the factory. Indication of the drive design is required for configuration. The transducer block leaves the mode "Out of Service" only if one of the two options "self-opening" or "self-closing" is set.

From the setting of the "Actuator Fail Action" the transducer block determines whether or not the connected auxiliary valve must be controlled electrically for starting a set position set by the function block.

If a double-acting drive shall be controlled this must be done via two channels and thus via two DO function blocks and two transducer blocks.

## 4.5.4 Final Position Feedback

The response of the final position feedback is influenced via two parameters:

- "Sensor usage" describes whether a final position feedback is connected to the Valve Coupler and whether its signals shall be evaluated.
- If the signal of the final position feedback are evaluated, "PV\_D generation" determines how to further process the evaluated PFC signals prior to transferring them to the function block.



Note

*When using the setup wizard, the type of position feedback is analyzed and "Sensor usage" is set automatically at one of the options A to D.*

*To manually set the parameter "Sensor usage" and "PV\_D generation" the "target mode" of the transducer block must be set to "Out of Service (OOS)" as it is possible only here to make a modification.*

### Prerequisite

The parameter "Actuator Fail Action" was assigned a value for the design of the drive.

### "Sensor Usage"

The following settings are possible:

- No position detection
- Use sensor values for PV\_D
- A: C2, I0, O1
- B: C1, I3, O2
- C: C1, I0, O2
- D: C2, I3, O1

The value "no position detection" means that no final position feedback is connected to the Valve Coupler. The current reference value is returned as valve position to the function block.

## Fieldbus Valve Coupler FD0-VC-Ex4.FF Parameterization and Operation of the Valve Coupler

If "Use sensor values for PV\_D" is selected, the two signals of the PFCs are transferred to the function block without evaluation. The two binary signals are represented on bit 0 (PFC A) and bit 1 (PFC B). Here, numerical values can be generated from 0 ... 3. The problems which may result here are described in section "PV\_D generation".

 *The Valve Coupler interprets a PFC signal as follows:*  
*high current => logical 1*  
*low current => logical 0*

Note

When selecting one of the options A to D, the transducer block determines from the PFC signals in which position ("open", "closed", "intermediate") the valve is just at that moment. Whether an actuated sensor or activated mechanical contact represents an open or closed valve, depends on the construction of the position feedback and the electrical characteristics of the PFCs. A general representation is thus not possible. Each of the four options corresponds to one set of combinations of the two PFC signals and the valve positions "open", "intermediate" and "closed". The following four tables show which valve position which combination of the signals of PFC A and PFC B are assigned for the options A to D.

Sensor usage = A		
Valve position	PFC A	PFC B
Closed	0	1
Intermediate position	0	0
Open	1	0
Uncertain	1	1

Sensor usage = B		
Valve position	PFC A	PFC B
Closed	1	0
Intermediate position	1	1
Open	0	1
Uncertain	0	0

Sensor usage = C		
Valve position	PFC A	PFC B
Closed	1	0
Intermediate position	0	0
Open	0	1
Uncertain	1	1

Sensor usage = D		
Valve position	PFC A	PFC B
Closed	0	1
Intermediate position	1	1
Open	1	0
Uncertain	0	0

 *One of the options A to D must be selected in order to make use of time monitoring, stroke counter function or cyclic functional tests.*

Note

The letter/number combinations after the options A to D give the signal input for the positions "open" (O), "intermediate" (I) and "closed" (C). The assignment of the PFC signals "0" and "1" to the numerical values 0 ... 3 is given in the following table.

Number	PFC A	PFC B
0	0	0
1	1	0
2	0	1
3	1	1

### "PV\_D Generation"

If one of the options A to D was selected under "Sensor usage", "PV\_D generation" can be used to determine whether and how to further treat the evaluated signals prior to transferring them to the function block. The following options can be selected:

- Valve Position
- Valve Position Extended
- Intermediate => Closed
- Intermediate => Open
- Intermediate => Next
- Intermediate => Last (default)

#### Valve Position:

The position of the valve is transferred to the function block as a numerical value:

Numerical value	Valve position
1	<i>Closed</i>
2	<i>Open</i>
3	<i>Intermediate position</i>
0	<i>Unknown</i>

#### Valve Position Extended:

The information about the valve position is extended in the intermediate position by the information "opens" and "closes". This information is determined from the current control process and need not coincide with the actual direction of travel (e. g., when changing the set position while the valve is in the intermediate position).

Numerical value	Valve position
1	<i>Closed</i>
2	<i>Open</i>
3	<i>Intermediate position/opening</i>
4	<i>Intermediate position/closing</i>
0	<i>Unknown</i>

The two options "Valve Position" and "Valve Position Extended", as well as the setting "Use sensor values for PV\_D" in Sensor usage generate a problem for the function block:

As shown in section 4.3, the valve position transferred from the transducer block to the function block is given in the parameter READBACK\_D. From there it is transferred to the Parameter PV\_D which (via BKCAL\_OUT\_D) can be transferred to a control system in cycles or used in a function block application.

If an inversion is active in the function block, the numerical value "0" becomes "1" and all numerical values unequal to zero become "0". I. e., all valid valve positions are inverted to "0".

Also the IO options of the DO function block "SP-PV Track in LO" and "SP-PV Track in Man" are no longer functioning because the range of values of PV\_D does not correspond to that of SP\_D.

To solve these problems and to allow a more simple use of the valve position in the function block application, the valve position can be shown at the range of values of the set position ["closed" (0) or "open" (1) ] by means of the four remaining options. These four options determine which position shall be output in the intermediate position:

Intermediate => Closed	<i>The intermediate position is always interpreted as "closed"</i>
Intermediate => Open	<i>The intermediate position is always interpreted as "open"</i>
Intermediate => Next	<i>During a closing process, the intermediate position is always interpreted as "closed" and during an opening process as "open"</i>
Intermediate => Last (default setting)	<i>During a closing process, the intermediate position is interpreted as "open" and during an opening process as "closed"</i>

The default setting "Intermediate => Last" has the effect that during an opening and/or closing process the

last position is displayed until the valve has reached the reference position actually. This may be used e. g., in a sequential control when one should wait in the chain of steps until the valve has reached the desired position after being controlled. Then only the reference value must be compared with the feedback.

### 4.5.5 Target Mode

The "target mode" determines the mode of operation of the Valve Coupler. The following settings are possible:

- OOS, Out of Service (default setting)
- Auto
- Man, Manual

In mode "Out of Service" the transducer block is deactivated and the valve output is not controlled. Thus, a connected drive moves in its mechanical safety position. This mode should be set if basic function parameters ("Actuator Fail Action", "Sensor usage" and "PV\_D generation") shall be modified or if the channel which belongs to that transducer block is not used.

The "Auto" mode is provided for operation. The transducer block operates in this mode as specified by parameterization.

"Man" is used by the setup wizard and must not be modified.

### 4.5.6 Time Monitoring

With the "Time Monitoring" activated, the breakaway and transit times of the connected valve are measured and compared with the reference values during each reference value modification of the valve position. If a measured time falls below or exceeds the associated reference time by a specified allowance an alarm is generated. The times measured last are also displayed (see section 4.6.3).

#### Prerequisite

The following is required for time monitoring:

- Parameterisation of "Actuator Fail Action" - section 4.5.3
- Parameterisation of "Sensor usage" - section 4.5.4

#### Activation of Time Monitoring

Time monitoring is activated by setting the option "Time Monitoring" in parameter "Valve Monitoring".

#### Enter Reference Times

The reference times for the four different monitoring times are entered in seconds during commissioning. For the definition of the breakaway and transit times please refer to figure 4.4.

Each reference value consists of the proper reference value in seconds and the maximum admissible percentage deviation. An alarm is generated if a measured time falls below or exceeds the admissible allowance.

- Range of values of reference value of breakaway times: 0 s to 60 s
- Range of values of reference value of transit times: 0 s to 180 s
- Range of values, max. deviation: 0 % to 100 %

The accuracy of time measurement is +/- 0.05 s



Note

*These parameters are set automatically when using the setup wizard. The current times of the valve are set as the reference times. The maximum admissible deviation is set to 30 %. This allowance can be adapted for each time individually to the plant specific conditions, if necessary.*

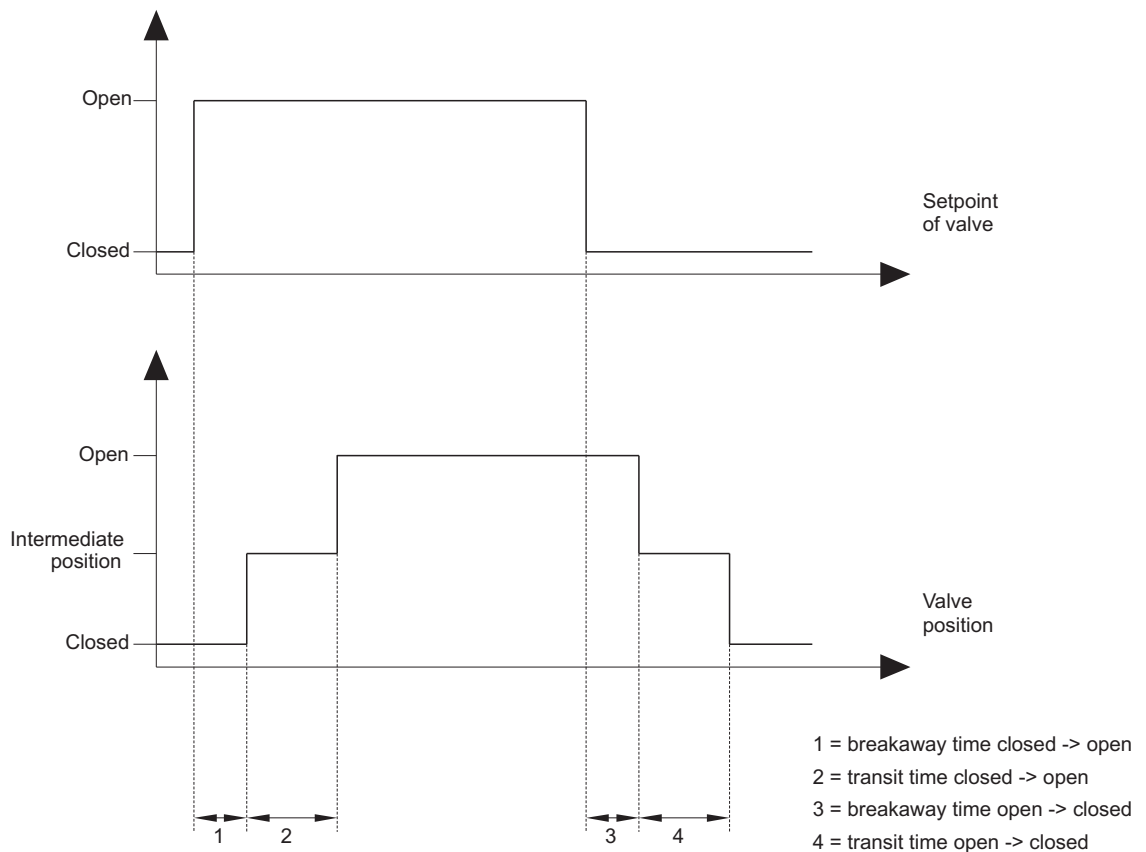

Figure 4.4: Definition of breakaway and transit times

#### 4.5.7 Cyclic Functional Test

##### Prerequisite

The following is required for the cyclic functional test function:

- Parameterization of "Actuator Fail Action" - section 4.5.3
- Parameterization of "Sensor usage" - section 4.5.4
- Time monitoring is activated - section 4.5.6

##### "Cyclic Test Open" and "Cyclic Test Closed"

The Valve Coupler is provided with the feature to check the connected valve for proper functioning during an adjustable period of time. Thus it is possible to monitor a valve which is rarely triggered, for faults which might prevent the latter from functioning properly. Here, the Valve Coupler controls the valve contrary to the current control until breakaway of the valve is recognized, and then controls the valve back into the initial position. The measured breakaway time is displayed as the breakaway time measured last, and falling below or exceeding the admissible range of values is signalled as an alarm.

Depending on the operation, the cyclic functional test for the valve position "open" and/or "closed" can be switched ON or OFF under the parameter "Valve Monitoring". However, this is possible only if "Time Monitoring" is activated in the "Valve Monitoring".

## "Period Cyclic Test"

The period of time for the cyclic functional test can be set between 10 secs and 7 days, 23 hours, 59 minutes and 59 seconds. If the set valve position is not modified for this period of time, the device carries out a cyclic functional test automatically.

### 4.5.8 Stroke Counter

#### Prerequisite

The following is required for the stroke counter function:

- Parameterization of "Actuator Fail Action" - section 4.5.3
- Parameterization of "Sensor usage" - section 4.5.4

#### "Stroke Counter"

This function can be activated by setting the option "Stroke Counter" in parameter "Valve Monitoring". The count in parameter "Stroke Counter" is always then incremented by one as soon as the valve has reached the valve position "open" after having modified the reference value. This means, that a movement from "open" to "closed" and back to "open" corresponds to a stroke.

This parameter can be initialized with a start value. The current count remains unaffected even after a voltage failure.

#### "Stroke Counter Limit"

A count can be entered as the limit value for the counter function. If the count of the stroke counter exceeds the entered "Stroke Counter Limit" the alarm "Maintenance Needed Now" is generated. No alarm is given if the "Stroke Counter Limit" is zero. Thus it is possible to count the number of strokes without releasing an alarm for a limit value.

### 4.5.9 Lead Breakage and Lead Short Circuit Monitoring

#### "Valve Lead Fault Monitoring"

Monitoring of the valve lead is switched ON if the option "Short Circuit Valve" and/or "Lead Breakage Valve" are set in the "Valve Lead Fault Monitoring" parameter. Short circuit monitoring functions only with the auxiliary valve controlled as the switch-on and/or holding current is required to recognize the short circuit. If the auxiliary valve is deactivated before the lead fault is eliminated, the associated alarm is reset only if the valve is controlled again and no short circuit occurs.



Note

*The cyclic functional test enables also a periodic lead shot circuit monitoring with a normally not controlled auxiliary valve.*

#### "Sensor Lead Fault Monitoring"

Monitoring of the sensor lead is switched ON if the option "Short Circuit Sensor" and/or "Lead Breakage Sensor" are set in the "Sensor Lead Fault Monitoring" parameter.

## 4.5.10 Valve and Drive Information

Information of the valve drive or transducer block can be entered in the following parameters. The first three parameters are a component of all FOUNDATION Fieldbus blocks. Their use depends on the control system.

- „STRATEGY“  
Grouped blocks can be identified by entering a number. This number is not controlled or used by the block.
- „ALERT\_KEY“  
Identification number for the plant unit which is used by the master computer to sort e. g., alarm or operation messages. Values from 0 to 65535 are valid.
- „TAG\_DESC“  
Description of the task of the TB.
- "Mechanical drive manufacturer"
- "Mechanical drive model"
- "Mechanical drive serial number"
- "Valve manufacturer"
- "Valve model"
- "Valve type" - undefined, linear, turning, other
- "Valve serial number"

## 4.6 Process Information

### 4.6.1 Valve Reference Value

The reference value for the valve position and the associated status are shown in the "Final Value" parameter (reference value). The "Final Value" is a copy of the OUT\_D value of the DO function block connected with the transducer block. This reference value can assume the values "closed" (0) or "open" (unequal to 0). The value is accepted only with a status "Good NonCascade" or "Good Cascade". If the status is "Bad" or "Uncertain", the connected auxiliary valve is not controlled electrically, so that the associated drive moves into the mechanical safety position.

### 4.6.2 Valve Position

The signals recorded by a connected final position feedback are indicated in several parameters of different significance.

#### "Sensor Value A"

This parameter displays the input signal of PFC A. The Valve Coupler interprets a PFC signal as follows:

high current      => logical 1  
low current       => logical 0

#### "Sensor Value B"

See "Sensor Value A".

#### "Valve Position"

The current valve position "open", "intermediate" or "closed" is displayed as value. By parameterizing the "Sensor usage" (section 4.5.4), the signals of the PFCs are assigned a definite position.V

#### "Extended Valve Position"

The information in "Valve Position" is extended in the intermediate position by the information "opening" and "closing". This information is determined from the current control process and need not coincide with the actual direction of travel (e.g., when changing the set position while the valve is in the intermediate position).

### "PRIMARY\_VALUE\_D"

The parameter "PRIMARY\_VALUE\_D" gives the value which is fed back as valve position to the assigned function block. "PRIMARY\_VALUE\_D" is an unsigned 8 with the status which is displayed in the function block as READBACK\_D.

Which information is issued at which range of values in "PRIMARY\_VALUE\_D" depends on the parameterization of "Sensor usage" and "PV\_D generation" (section 4.5.4).

### "Valve Information"

This parameter displays information of the current status of the valve and/or transducer block. The following information is given:

- Stroke counter limit exceeded
- Cyclic functional test running
- Actuation - The valve has not yet reached the new final position after having changed the reference value.

### 4.6.3 Breakaway and Transit Times

With the "Time Monitoring" activated, the breakaway and transit times are measured during each opening and closing process of the valve and displayed in the parameters shown below. These values are not stored in the device, i. e., after a power loss these values will not be available until after the valve has been opened and closed once.

If during time measuring is recognized that at valve blocks, the time measured just at that moment is set to the value 9999 s.

- "Breakaway time closed -> open"
- "Transit time closed -> open"
- "Breakaway time open -> closed"
- "Transit time open -> closed"

### 4.7 Diagnosis Messages and Alarms

The Valve Coupler FD0-VC-Ex4.FF is provided with several diagnostic options which are given in section 4.4.

If a fault occurs, the transducer block sets a block alarm. The block alarm is a combined error signal for all fault signals and remains set as long as a fault in the block exists. To receive detailed information of the alarm cause after a block alarm, the Valve Coupler provides the following parameters:

- BLOCK\_ERR
- XD\_ERROR
- Valve Lead Fault
- Sensor Lead Fault
- Valve Warnings
- Valve Error
- Valve Information

In section 5.3 a detailed list is given for the messages of these parameters and hints for fault elimination.



If the used control system supports alarm messages via the FOUNDATION Fieldbus, setting and resetting of the block alarm is transferred via the bus to the control system. As this function is currently not supported by all control systems, the Valve Coupler has a second possibility to display faults:

As soon as the transducer block recognizes a fault, a message is set in parameter "BLOCK\_ERR" of the connected DO function block. Normally, this parameter is read out and evaluated in cycles by control systems which do not support alarm messages via FOUNDATION Fieldbus. If the fault is related to the valve control (e. g., lead breakage of valve feeding lead or exceeding the admitted valve transit time), the message "Output Failure" is set. If the final position feedback fails (e.g., lead short circuit of PFC feeding lead), the message is "Input Failure".

All messages, except a configuration error, are transferred by this mechanism. Therefore check after each modification of parameterization of the Valve Coupler that this message is not set in parameter "BLOCK\_ERR".



**Note**

*If the control system used does not support alarm messages via FOUNDATION Fieldbus, deactivate the option "reports" in parameter "FEATURES\_SEL" of the resource block.*

# Fieldbus Valve Coupler FD0-VC-Ex4.FF Parameterization and Operation of the Valve Coupler

Part No.: 108227, Date of issue 15.02.2013

## 5 Error Detection and Troubleshooting

### 5.1 LEDs

The valve interface is provided with 6 LEDs at the front of the device which inform about the status of the device and about errors related to the hardware which must be eliminated locally under normal circumstances.

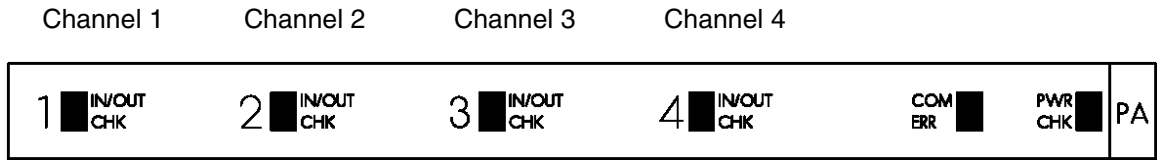

Figure 5.1: LEDs at device

LED	States	Cause	Solution
<i>PWR CHK</i> <sup>1</sup>	<i>OFF</i>	<i>No power supply.</i>	<ul style="list-style-type: none"> <li>• <i>Check power supply.</i></li> <li>• <i>Check wiring of FOUNDATION Fieldbus.</i></li> </ul>
	<i>Permanently green</i>	<i>Power supply available, device is ready to operate.</i>	
<i>COM ERR</i>	<i>OFF</i>	<i>No communication errors.</i>	
	<i>Flashing red</i>	<i>No bus activity or bus error.</i>	<ul style="list-style-type: none"> <li>• <i>Check wiring.</i></li> <li>• <i>Check LAS.</i></li> </ul>
	<i>Permanently red</i>	<i>Hardware error.</i>	<i>Send device to manufacturer.</i>
<i>IN/OUT CHK</i> (Channel 1...4)	<i>OFF</i>	<i>No errors detected.</i>	
	<i>Flashing red</i>	<i>Lead breakage or short circuit of PFC or valve lead.</i>	<ul style="list-style-type: none"> <li>• <i>Inform about exact error in device, refer to diagnosis messages.</i></li> <li>• <i>Check PFC and valve line of affected channel.</i></li> </ul>

<sup>1</sup> Attention: The light intensity is low for reasons of power saving.

### 5.2 Resource Block

Problem		Solution of error	
Parameter	Message	Cause	Solution
<i>BLOCK_ERR</i>	<i>Lost Static Data</i>	<i>The parameterization data stored in the device were faulty and replaced by the default settings.</i>	<i>Repeat parameterization. If this error occurs repeatedly, send the device to Pepperl+Fuchs for repair.</i>
	<i>Device Maintenance</i>	<i>Hardware error.</i>	<i>Send device to Pepperl+Fuchs for repair.</i>
	<i>Simulation</i>	<i>Simulation allowed by setting the switch 1.</i>	<i>Check whether simulation shall be allowed.</i>
	<i>OOS</i>	<i>The target mode of the block is OOS.</i>	<i>Set block to "Auto" mode.</i>
<i>RS_STATE</i>	<i>Online</i>	<i>No error.</i>	
	<i>Failure</i>	<i>Hardware error.</i>	<i>Send device to Pepperl+Fuchs for repair.</i>
	<i>Stand-by</i>	<i>The target mode of the block is OOS.</i>	<i>Set block into "Auto" mode.</i>
	<i>Online Linking</i>	<i>One or several communication links to other field devices are not established.</i>	<ul style="list-style-type: none"> <li>• <i>Check whether all necessary field devices are available at the segment.</i></li> <li>• <i>Check configuration.</i></li> </ul>

**5.3 Transducer Block**

**Diagnosis Messages**

Problem		Solution of error	
Parameter	Message	Cause	Solution
BLOCK_ERR	Block Configuration Error	The target mode is "AUTO" or "MAN" and the parameter "Actuator Fail Action" is at "undefined".	Parameterize the "Actuator Fail Action" by entering the drive mode "self-closing" or "self-opening", see section 4.5.3.
		Time monitoring or Stroke Counter are ON and "Sensor Usage" is at "No Position Detection" or "Use Sensor Values for PV_D".	Set or automatically determine "Sensor Usage" according to section 4.5.4 to one of the options A ... D.
		Time monitoring is ON and one of the reference values for time monitoring is at "0".	Enter reference values according to section 4.5.6 or determine them automatically by means of starting the setup wizard.
	Input Failure	The status of the valve position fed back to the function block (PRIMARY_VALUE_D) is "bad".	See "status values of process parameters".
	Output Failure	Combined error signal of the errors displayed in "XD_ERROR".	See „XD_ERROR“.
Maintenance Needed	The "Stroke Counter Limit" has been exceeded.	Drive and valve need maintenance since the stroke number specified for this case has been exceeded. Then increase the "Stroke Counter Limit" or reset the counter value in the "Stroke Counter".	
Device Maintenance	Combined error signal of the errors displayed in "Valve Warning".	See "Valve Warning".	
XD_ERROR	Mechanical error	Combined error signal of the errors displayed in "Valve Error".	See "Valve Error".
	Valve Lead Fault	Combined error signal of the errors displayed in "Valve Lead Fault Monitoring".	See "Valve Lead Fault Monitoring".
	Sensor Lead Fault	Combined error signal of the errors displayed in "Sensor Lead Fault Monitoring".	See "Sensor Lead Fault Monitoring".

Part No.: 108227, Date of issue 15.02.2013

Problem		Solution of error	
Parameter	Message	Cause	Solution
Valve warning	Breakaway time ... too long Transit time ... too long  (... = C->O or O->C)	The measured time was longer than the reference value plus the admissible allowance.	<ul style="list-style-type: none"> <li>• Check auxiliary power.</li> <li>• Check reference times and allowances.</li> <li>• Check PFCs for proper functioning.</li> <li>• Check friction of valve.</li> </ul>
	Breakaway time ... too short Transit time ... too short  (... = C->O or O->C)	The measured time was shorter than the reference value minus the admissible allowance.	<ul style="list-style-type: none"> <li>• Check auxiliary power.</li> <li>• Check reference times and allowances.</li> <li>• Check PFCs for proper functioning.</li> <li>• Check friction of valve.</li> </ul>
Valve error	Valve blocked	The valve is signalled blocked, if a time $t > 5 \cdot (\text{breakaway time} + \text{transit time})$ elapsed since the issue of the new reference value.	<ul style="list-style-type: none"> <li>• Check reference times.</li> <li>• Check PFCs for proper functioning.</li> <li>• Check auxiliary power.</li> <li>• Test valve drive.</li> </ul>
	Valve left final position	The valve has left the reached final position without modification of the reference value for the valve position.	<ul style="list-style-type: none"> <li>• Check parameterization of "Sensor Usage" (section 4.5.4).</li> <li>• Check PFCs for proper functioning.</li> <li>• Check auxiliary power.</li> <li>• Test valve drive.</li> </ul>
	Position detection failure	The signal combination of the PFCs is not assigned to a valve position.	<ul style="list-style-type: none"> <li>• Check parameterization of "Sensor Usage" (section 4.5.4).</li> <li>• Check PFCs for proper functioning.</li> </ul>
The PFCs have signalled an unexpected valve position; open - intermediate - closed and/or vice versa was expected.		<ul style="list-style-type: none"> <li>• Check parameterization of "Sensor Usage" (section 4.5.4).</li> <li>• Check PFCs for proper functioning.</li> <li>• Check auxiliary power.</li> <li>• Test valve drive.</li> </ul>	
Valve Lead Fault	Short Circuit Valve	Lead short circuit at valve lead.	Check wiring.
	Lead Breakage Valve	Lead interruption at valve lead.	Check wiring.
Sensor Lead Fault	Short Circuit Sensor A/B	Lead short circuit at lead to PFC A/B.	Check wiring.
	Lead Breakage Sensor A/B	Lead interruption at lead to PFC A/B.	Check wiring.

**Status values of process parameters**

Status messages	Cause	Solution	Cross reference
Bad - Out of Service	Mode of block is "Out of Service"	Specify target mode "AUTO".	See section 4.5.5 and "Diagnosis messages".

Part No.: 108227, Date of issue 15.02.2013

## Fieldbus Valve Coupler FD0-VC-Ex4.FF Error Detection and Troubleshooting

Status messages	Cause	Solution	Cross reference
<i>Bad - Device Failure</i>	<i>Hardware error</i>	<i>Send device to Pepperl+Fuchs for repair.</i>	
<i>Bad - Sensor Failure, Low limited</i>	<i>Lead interruption sensor</i>	<i>Determine the affected sensor in the device from the "Sensor Lead Fault" parameter.</i>	<i>See "lead error sensor".</i>
<i>Bad - Sensor Failure, High limited</i>	<i>Lead short circuit sensor</i>	<i>Determine the affected sensor in the device from the "Sensor Lead Fault" parameter.</i>	<i>See "lead error sensor".</i>
<i>Bad - Sensor Failure</i>	<i>"Position detection failure"; the signal combination of the PFCs is not assigned to a valve position</i>	<ul style="list-style-type: none"> <li>• <i>Check parameterization of "Sensor Usage".</i></li> <li>• <i>Check PFCs for proper functioning.</i></li> </ul>	<i>See "diagnosis messages" and section 4.5.4.</i>
<i>Bad - Non Specific</i>	<i>This value is not used due to the current parameterization</i>	<i>Check parameterization of "Sensor Usage".</i>	<i>See section 4.5.4.</i>

### Miscellaneous

Problem	Cause	Solution	Cross reference
<i>The transducer block does not leave the "Out of Service" mode</i>	<i>There is a block configuration error which is signalled in "BLOCK_ERR"</i>	<i>Parameterize the "Actuator Fail Action", by entering the drive mode "self-closing" or "self-opening".</i>	<i>See section 4.5.3 and 5.3 „BLOCK_ERR“.</i>
	<i>The resource block is in "Out of Service" mode</i>	<i>Set resource block into "AUTO" mode.</i>	<i>See also section 5.2.</i>
<i>Auxiliary valve not controlled</i>	<i>The reference value specified by the DO function block has the status "bad" or "uncertain"</i>	<i>Check reference value, correct, if necessary.</i>	<i>See section 4.6.1.</i>
	<i>Transducer block is in "Out of Service" mode</i>	<i>Set transducer block into "AUTO" mode.</i>	<i>See also section 5.3.</i>
	<i>Hardware or lead error</i>	<i>Check diagnosis messages.</i>	<i>See also section 5.3.</i>
	<i>Simulation is switched ON in function block</i>	<i>Switch OFF simulation.</i>	<i>See section 3.2.2 and Appendix B.</i>

**5.4 Function block DO**

**Diagnosis messages**

Problem		Elimination of error	
Parameter	Message	Cause	Solution
BLOCK_ERR	Block Configuration Error	The parameter "CHANNEL" has not been assigned a valid value (1 ... 4).	Assign valid value (see section 4.3).
		The function block was not assigned a schedule.	Include the function block in a function block application and load this in the device.
		The target mode of the block is "RCas" and "SHED_OPT" is at "undefined".	Assign valid value, e. g. "Normal Schedule - Normal Return".
	Input Failure	The status of PV_D is "bad".	<ul style="list-style-type: none"> <li>• Check the value fed back by the transducer block.</li> <li>• Check diagnosis message of transducer block.</li> </ul>
	Output Failure	There is an error in the transducer block which affects the output.	Check diagnosis message of transducer block (section 5.3).
	Simulate	Simulation for this block is activated.	See section 3.2.2 and appendix B.
	Local Override	The reference value has been overwritten by the safety value via the bus due to as missing reference value specification.	<ul style="list-style-type: none"> <li>• Check communication.</li> <li>• Check device which specifies the reference value.</li> </ul>
Out of Service	The block is in "Out of Service" mode.	<ul style="list-style-type: none"> <li>• Select suitable target mode.</li> <li>• Check block configuration error.</li> </ul>	

**Miscellaneous**

Problem	Cause	Solution	Cross reference
The function block does not leave the "Out of Service" mode	There is a block configuration error which is signalled in "BLOCK_ERR".	See "Diagnosis messages".	See "Diagnosis messages".
	The resource block is in "Out of Service" mode.	Set resource block into "AUTO" mode.	See also section 5.2.
The value of OUT_D is displayed in READBACK_D instead of the value fed back by the transducer block	The option "readback supported" in parameter "FEATURES_SEL" of the resource block is not set.	Set option.	
The value of OUT_D is not transferred to the transducer block	Simulation is ON.	Switch OFF simulation.	
Simulation cannot be activated	The simulation switch is not switched ON.	Check in resource block whether the simulation switch is ON; switch ON, if necessary.	See also section 3.2.2.
Parameters cannot be written	Write protection activated.	Deactivate write protection.	See section 3.2.2 and appendix C.

Part No.: 108227, Date of issue 15.02.2013

**5.5 Function Block DI**

Diagnosis messages

Problem		Elimination of Error	
Parameter	Message	Cause	Solution
BLOCK_ERR	Block Configuration Error	A value other than 5 has been assigned to the parameter „CHANNEL“.	Set „CHANNEL“ to 5.
		No schedule was assigned to the function block.	Integrate the function block into a function block application and load this into the device.
	Input Failure	The transducer blocks report a status of "Bad - Device Failure". This might be caused by a hardware error.	Send the device to Pepperl+Fuchs for repair.
	Simulate	Simulation is active for this block.	See chapter 5.4.2 and appendix B.
	Out of Service	The block is in „Out of Service“ mode.	<ul style="list-style-type: none"> <li>• Select suitable target mode.</li> <li>• Check Block Configuration Error.</li> </ul>

Miscellaneous

Problem	Cause	Solution	Cross reference
The function block does not leave the „Out of Service“ mode	There is a block configuration error which is signalled in "BLOCK_ERR".	See "Diagnosis messages".	See "Diagnosis messages".
	The resource block is in "Out of Service" mode.	Set resource block into "AUTO" mode.	See also section 5.2.
The value of OUT_D is not the same as the PFC sensor values measured by the transducer blocks.	Simulation is active.	Switch off simulation.	
	I/O-Option "Invert" is active.	Switch off "Invert" option.	
	The function block is in "Man" mode.	Set function block to "Auto" mode.	
The value of OUT_D is not refreshed or shows strange behavior.	The parameter "PV_FTIME" does not equal 0.	Set parameter value "PV_FTIME" to 0.	
Simulation cannot be activated.	The simulation switch is not switched ON	Check in resource block whether the simulation switch is ON; switch ON, if necessary.	See also section 3.2.2..
Parameters cannot be written.	Write protection activated.	Deactivate write protection.	See section 3.2.2 and appendix C.

Status values of process parameters

Part No.: 108227, Date of issue 15.02.2013



Status message	Cause	Solution	Cross reference
<i>Bad - Out of Service</i>	<i>Mode of the block is „Out of Service“</i>	<i>Set Target Mode to „AUTO“.</i>	
<i>Bad - Device Failure</i>	<i>Hardware Error</i>	<i>Send device to Pepperl+Fuchs for repair.</i>	
<i>Uncertain - Initial Value</i>	<i>Not all transducer blocks are in "Auto" mode.</i>	<i>Set transducer blocks to "Auto" mode.</i>	<i>See also section 6.5.5</i>

## 5.6 Initialization Run ("Auto Init Command")

Message	Cause	Solution
<i>Error before start:</i>	<i>Valve is actuating.</i>	<i>Start initialization run again as soon as the valve has reached the set position.</i>
	<i>Lead breakage or short circuit at valve or sensor.</i>	<i>Check wiring of sensors and valve.</i>
	<i>Valve is not in final position.</i>	<ul style="list-style-type: none"> <li>• <i>Check PFCs.</i></li> <li>• <i>Check auxiliary power.</i></li> <li>• <i>Check drive.</i></li> </ul>
	<i>Resource block is in "Out of Service" mode.</i>	<i>Set resource block into "Auto" mode.</i>
<i>Error while running:</i>	<i>The PFCs have displayed an unexpected valve position (not: open-intermediate-closed and vice versa).</i>	<i>Check PFCs and contacts.</i>
	<i>Breakaway time is longer than 1 min.</i>	<ul style="list-style-type: none"> <li>• <i>Auxiliary power too low.</i></li> <li>• <i>Friction too high.</i></li> <li>• <i>Drive or pilot valve defective.</i></li> <li>• <i>System pressure too high.</i></li> </ul>
	<i>Transit time is longer than 3 min.</i>	<ul style="list-style-type: none"> <li>• <i>Auxiliary power too low.</i></li> <li>• <i>Friction too low.</i></li> <li>• <i>Drive or pilot valve defective.</i></li> </ul>
	<i>The lead and/or short circuit monitor has detected an error.</i>	<ul style="list-style-type: none"> <li>• <i>Check wiring of sensors and valve.</i></li> <li>• <i>See also section 5.1 and 5.3.</i></li> </ul>



## A Transducer Block

The column "Char." shows which characteristics or conditions are applicable to this parameter. The following is applicable here:

- OOS (Out of Service)  
The parameter can be written only if the target mode of the block is "Out of Service".
- S (Static)  
During each writing process to such an identified parameter the parameter ST\_REV is increased by one.
- W (Writeable)  
The parameter can be modified by the user.

As all parameters can be read this is not marked especially.

Parameter	Char.	Description
ST_REV		During each writing process to a parameter marked by "S" the parameter ST_REV is increased by one.
TAG_DESC	W S	Via this parameter the valve interface can be assigned a tag (measuring point designation) within the plant and/or process.
STRATEGY	W S	The strategy field can be used to identify comprising blocks. These data are not controlled or used by the block.
ALERT_KEY	W S	Identification number of the plant unit. This information can be used by the control system, e.g., to sort alarms. Valid values are 1 ... 65536.
MODE_BLK	W S	Displays the current, allowed normal mode and the target mode of the block. The target mode can be set to the values "Auto" or "Out of Service".
BLOCK_ERR		Displays diagnosis messages of the block.
UPDATE_EVT		This parameter is used to signal to the control system that a parameter marked by "S" was overwritten if the control system supports alarm messages.
BLOCK_ALM		This parameter is used to signal to the control system diagnosis messages displayed in BLOCK_ERR and XD_ERROR, if the control system supports alarm messages
Transducer Directory TRANSDUCER_DIR		This directory includes information of the structure of the transducer block.
Transducer type TRANSDUCER_TYPE		Includes information of the type of transducer block (manufacturer specific).
XD Error XD_ERROR		Displays diagnosis messages of the block.
Collection Directory COLLECTION_DIR		This directory includes information of the structure of the transducer block.
Associated channel ASSOCIATED_CHANNEL		This channel number must be entered in the "CHANNEL" parameter of a DO function block in order to connect it with the transducer block.
Final value FINAL_VALUE_D		Includes the valve reference value prescribed by the connected DO function block.
Valve Lead Fault Monitoring VALVE_LEAD_FAULT_MONITORING	W S	In this parameter the lead breakage and/or lead short circuit monitoring can be activated for the valve wiring.
Valve Lead Fault VALVE_LEAD_FAULT		Lead breakage and lead short circuit of the valve wiring are displayed here if monitoring has been activated.
Actuator Fail Action ACT_FAIL_ACTION	W S OOS	In this parameter the mechanical safety position of the actuator (drive unit) is parameterized. Parameterization is required for the proper functioning of the transducer block. Possible values are "self-opening" and "self-closing".
Actuator manufacturer ACT_MAN	W S	Name of actuator manufacturer.

## Fieldbus Valve Coupler FD0-VC-Ex4.FF Transducer Block

Parameter	Char.	Description
Actuator model ACT_MODEL	W S	Actuator design.
Actuator serial number ACT_SER_NUM	W S	Serial number of the actuator.
Valve manufacturer VALVE_MAN	W S	Name of valve manufacturer.
Valve model VALVE_ID	W S	Valve design.
Valve type VALVE_TYPE	W S	Describes the type of valve (linear, turning, other, undefined).
Valve serial number VALVE_SER_NUM	W S	Serial number of the valve.
PRIMARY_VALUE_D		The valve position which is transferred to the function block.
Valve position VALVE_POSITION_D		The current valve position (closed, open, intermediate, unknown).
Valve Position Extended VALVE_POSITION_EXTEN DED_D		The current valve position with additional information such as "valve opening" and "valve closing" if the valve is in the intermediate position.
Sensor Value A SENSOR_VALUE_A_D		The current value of PFC A (0 = low current, 1 = high current).
Sensor Value B SENSOR_VALUE_B_D		The current value of PFC B (0 = low current, 1 = high current).
Sensor Usage SENSOR_USAGE	W S OOS	This parameter describes whether a final position feedback is connected to the valve interface and whether or how its signals shall be evaluated.
PV_D Generation PV_D_GENERATION	W S OOS	If the signal of the final position feedback are evaluated, this parameter determines how to further process the evaluated PFC signals prior to transferring them to the function block.
Sensor Lead Fault Monitoring SENSOR_LEAD_ FAULT_MONITORING	W S	In this parameter the lead breakage and/or lead short circuit monitoring can be activated for the PFC wiring.
Sensor Lead Fault SENSOR_LEAD_ FAULT		Lead breakage and lead short circuit of the PFC wiring are displayed here if monitoring has been activated.
Valve Monitoring VALVE_MONITORING	W S	Time measurement for the valve, stroke counter and the cyclic functional tests can be activated in this parameter.
Stroke Counter STROKE_COUNTER	W	The current value of the stroke counter. This value is always increased by one as soon as the valve reaches the open position after a modification of the reference value. It is possible to specify a start value.
Stroke Counter Limit STROKE_ COUNTER_LIMIT	W S	As soon as the stroke counter exceeds this value, a diagnosis message is released.
Cyclic Test Period CYCLIC_TEST_PERIOD	W S	If the reference value of the valve is not modified for this time, a cyclic functional test is carried out (if activated).
Auto Init Command (initialization run) AUTO_INIT_CMD	W	The transducer block can automatically determine the parameter "Sensor Usage" and the reference values for the valve transit and break-away times during an initialization run. initialization is started by this parameter. This parameter should not be used directly but always via the Setup Wizard.
Auto Init Status (Status of initialization run) AUTO_INIT_STATUS		The current status of the initialization run is signalled here.

Part No.: 108227, Date of issue 15.02.2013

## Fieldbus Valve Coupler FD0-VC-Ex4.FF Transducer Block

Parameter	Char.	Description
Breakaway Time Close -> Open Setpoint BREAK_AWAY_TIME_CLOSE_OPEN_SP	W S	Reference value for the breakaway time from "closed" to "open". Range of values: Reference value: 0 s ... 60 s, max. adm. deviation: 0 % ... 100 %.
Transit Time Close -> Open Setpoint TRANSIT_TIME_CLOSE_OPEN_SP	W S	Reference value for the transit time from "closed" to "open". Range of values: Reference value: 0 s ... 180 s, max. adm. deviation: 0 % ... 100 %.
Breakaway Time Open -> Close Setpoint BREAK_AWAY_TIME_OPEN_CLOSE_SP	W S	Reference value for the breakaway time from "open" to "closed". Range of values: Reference value: 0 s ... 60 s, max. adm. deviation: 0 % ... 100 %.
Transit Time Open -> Close Setpoint TRANSIT_TIME_OPEN_CLOSE_SP	W S	Reference value for the transit time from "open" to "closed". Range of values: Reference value: 0 s ... 180 s, max. adm. deviation: 0 % ... 100 %.
Breakaway Time Close -> Open BREAK_AWAY_TIME_CLOSE_OPEN		The breakaway time from "closed" to "open" measured last; this value is not stored in the device, i.e., this value is available after a power failure only after opening and closing the valve once.
Transit Time Close -> Open TRANSIT_TIME_CLOSE_OPEN		The transit time from "closed" to "open" measured last; this value is not stored in the device, i.e., this value is available after a power failure only after opening and closing the valve once.
Breakaway Time Open -> Close BREAK_AWAY_TIME_OPEN_CLOSE		The breakaway time from "open" to "closed" measured last; this value is not stored in the device, i.e., this value is available after a power failure only after opening and closing the valve once.
Transit Time Open -> Close TRANSIT_TIME_OPEN_CLOSE		The transit time from "open" to "closed" measured last; this value is not stored in the device, i.e., this value is available after a power failure only after opening and closing the valve once.
Valve Warnings VALVE_WARNING		If a measured transit or breakaway time is higher and/or lower than the reference value plus/minus the max. admissible deviation, this is displayed here.
Valve Error VALVE_ERROR		If the transducer block recognizes mechanical valve faults, the latter are indicated here.
Valve Information VALVE_INFO		The information of the current status of the valve and/or transducer block are indicated here.

## B Function Blocks DO and DI

### Function Block DO

The column "Char." shows which characteristics or conditions are applicable to this parameter. The following is applicable here:

- OOS (Out of Service)  
The parameter can be written only if the target mode of the block is "Out of Service".
- S (Static)  
During each writing process to such an identified parameter the parameter ST\_REV is increased by one.
- W (Writeable)  
The parameter can be modified by the user.

As all parameters can be read this is not marked especially.

Parameter	Char.	Description
ST_REV		During each writing process to a parameter marked by "S" the parameter ST_REV is increased by one.
TAG_DESC	W S	Via this parameter the valve interface can be assigned a tag (measuring point designation) within the plant and/or process.
STRATEGY	W S	The strategy field can be used to identify comprising blocks. These data are not controlled or used by the block.
ALERT_KEY	W S	Identification number of the plant unit. This information can be used by the control computer, e.g., to sort alarms. Valid values are 1 ... 65536.
MODE_BLK	W S	Displays the current, allowed normal mode and the target mode of the block. The target mode can be set to the values "Auto", "Cas", "RCas", "Man" or "Out of Service".
BLOCK_ERR		Displays diagnosis messages of the block.
PV_D		The current valve position which is fed back by the transducer block. This parameter is taken over from READBACK_D and inverted with the inversion feature activated.
SP_D		Current reference value of block.
OUT_D		This value is calculated by the function block and is used as specified reference value for the transducer block.
SIMULATE_D	W	Simulation can be activated/deactivated via this structure. With the simulation ON, READBACK_D is specified via this parameter. Simulation can only be activated with the associated switch 1 (section 3.2.2) ON.
PV_STATE	W S	Is used by some control systems to assign text designations to the numeral values of PV_D.
XD_STATE	W S	Is used by some control systems to assign text designations to the numeral values of READBACK_D.
GRANT_DENY	W	Regulates the access rights between control system and local operator's stations for some control systems.

## Fieldbus Valve Coupler FD0-VC-Ex4.FF Function Blocks DO and DI

Parameter	Char.	Description
IO_OPTS	W S OOS	Options which allow the user to adapt the block algorithm to the task of the block. Possible options:  <i>Invert</i> <i>OUT_D</i> is calculated to: <i>SP_D</i> is inverted <i>Faultstate restart</i> After a device reset <i>SP_D</i> is set to the value of <i>FSTATE_VAL_D</i> . <i>Faultstate type</i> If fault state type is set, <i>SP_D</i> is set to <i>FSTATE_VAL_D</i> in case of fault, otherwise the last value is kept. <i>SP-PV Track LO</i> In case of fault <i>SP_D</i> is always set to the value of <i>PV_D</i> . Thus the current position of the valve is kept and not the last reference value. <i>Target to Man</i> In case of fault the target mode is modified to "Man" and the safe status is kept in this way. <i>SP-PV Track Man</i> If the target mode is "Man", <i>SP_D</i> is always set to the value of <i>PV_D</i> . <i>PV for BKCal_Out</i> As the value of <i>BKCAL_OUT_D</i> , <i>PV_D</i> is always used instead of <i>SP_D</i> in order to be able to use <i>PV_D</i> in a function block application.
STATUS_OPTS	W S OOS	Option which allows the user to adapt processing of the status by the block to the task of the block. The option is:  <i>Propagate Fail Bkwd</i> If this option is set, the function block does not signal by an own alarm if the status of <i>PV_D</i> becomes "bad" but transfers the status incl. substatus via <i>BKCAL_OUT_D</i> .
READBACK_D		This parameter gives the current valve position which is fed back by the transducer block.
CAS_IN_D		Via this parameter, the reference value is specified by another function block or a control system in the "Cas" mode.
CHANNEL	W S OOS	The channel number of a transducer block is entered in this parameter in order to connect the function block with this transducer block. Valid values are 1 ... 4.
FSTATE_TIME	W S	Time in seconds between the detection of a missing specified reference value and setting the safety value.
FSTATE_VAL_D	W S	This value is used as safety value if the I/O option <i>Fault state type</i> is set.
BKCAL_OUT_D	W	Feedback of the current valve position to a superior function block or a control system. The value of <i>BKCAL_OUT_D</i> is determined by the option <i>PV for BKCal_Out</i> .
RCAS_IN_D	W	Via this parameter, the reference value is specified by another function block or a control system in the "RCas".
SHED_OPT	W S	Defines the behavior of the block in "RCas" mode on detection of a missing specified reference value.
RCAS_OUT_D	W	Feedback of the current reference value to a control system.
UPDATE_EVT		This parameter is used to signal to the control system that a parameter marked by "S" was overwritten if the control system supports alarm messages.
BLOCK_ALM		This parameter is used to signal diagnosis messages which are displayed in <i>BLOCK_ERR</i> to the control system, if the control system supports alarm messages.

Part No.: 108227, Date of issue 15.02.2013

### Function Block DI

The column "Char." shows which characteristics or conditions are applicable to this parameter. The following is applicable here:

- OOS (Out of Service)  
The parameter can be written only if the target mode of the block is "Out of Service".
- Man  
The parameter can only be written if the target mode of the block is "Out of Service".
- S (Static)  
During each writing process to such an identified parameter the parameter ST\_REV is increased by one.
- W (Writeable)  
The parameter can be modified by the user.

As all parameters can be read this is not marked especially.

Parameter	Char.	Description
ST_REV		During each writing process to a parameter marked by "S" the parameter ST_REV is increased by one.
TAG_DESC	W S	Via this parameter the valve interface can be assigned a tag (measuring point designation) within the plant and/or process.
STRATEGY	W S	The strategy field can be used to identify comprising blocks. These data are not controlled or used by the block.
ALERT_KEY	W S	Identification number of the plant unit. This information can be used by the control computer, e.g., to sort alarms. Valid values are 1 ... 65536.
MODE_BLK	W S	Displays the current, allowed, normal mode and the destination mode of the block. The destination mode can be set to the values „Auto“, „Man“ or „Out of Service“.
BLOCK_ERR		Displays diagnosis messages of the block.
PV_D		Contains the current PFC sensor values, which are measured by the transducer blocks and are transmitted to the function block. This parameter is taken from FIELD_VAL_D.
OUT_D	W Man	Output/Transmission of current PFC sensor values to a higher level function block or a control system. OUT_D depends on the current mode. If this is "Auto", then OUT_D is taken from PV_D. If the mode is "Man", the user can write directly onto OUT_D.
SIMULATE_D	W S OOS	Using this structure, the simulation can be activated or deactivated. If the simulation is activated, this parameter determines FIELD_VAL_D. The simulation can only be activated with the associated switch 1 ON.
XD_STATE	W S	Used by some control systems to assign texts to the numerical values of FIELD_VAL_D.
GRANT_DENY	W	Regulates the access rights between control system and local operator's stations for some control systems.
IO_OPTS	W S OOS	Option which enables the user to adapt the block algorithm to the task of the block. This option is: Invert. PV_D is calculated as follows: A Boolean negation of FIELD_Val_D is carried out, i. e. PV_D becomes 1 if FIELD_VAL_D is 0. If FIELD_VAL_D is greater than 0 then PV_D becomes 0.
STATUS_OPTS	W S OOS	Option which enables the user to adapt the block's status processing to the task of the block. This option is: Propagate Fault Forward. If this option is used, the function block will not trigger an alarm itself if the status of PV_D becomes „Bad“. Rather, the status, including substatus, is passed on via OUT_D.

Part No.: 108227, Date of issue 15.02.2013



## Fieldbus Valve Coupler FD0-VC-Ex4.FF Function Blocks DO and DI

Parameter	Char.	Description
CHANNEL	W S OOS	<i>This parameter has to be set to 5 for the function block to connect to the transducer blocks.</i>
PV_FTIME	W S	<i>Time in seconds for which the PFC sensor values have to be stable before they are passed on to PV_D. It is recommended to set the value to 0, otherwise undesired behavior may occur.</i>
FIELD_VAL_D		<i>Contains the current PFC sensor values , which are measured by the transducer blocks and are transmitted to the function block.</i>
UPDATE_EVT		<i>This parameter is used to signal to the control system that a parameter marked by "S" was overwritten if the control system supports alarm messages.</i>
BLOCK_ALM		<i>This parameter is used to signal diagnosis messages which are displayed in BLOCK_ERR to the control system, if the control system supports alarm messages.</i>
ALARM_SUM		<i>The current status of the alarm messages of the block.</i>
ACK_OPTION	S W	<i>Determines if alarms of the function block have to be confirmed or not.</i>
DISC_PRI	S W	<i>Priority of discrete alarm</i>
DISC LIM	S W	<i>Discrete input state, in which an alarm should be generated.</i>
DISC_ALM	S W	<i>The current state of the discrete alarm, along with a time and date stamp.</i>

## C Resource Block

The column "Char." shows which characteristics or conditions are applicable to this parameter. The following is applicable here:

- OOS (Out of Service)  
The parameter can be written only if the target mode of the block is "Out of Service".
- S (Static)  
During each writing process to such an identified parameter the parameter ST\_REV is increased by one.
- W (Writeable)  
The parameter can be modified by the user.

As all parameters can be read this is not marked especially.

Parameter	Char	Description
ST_REV	.	During each writing process to a parameter marked by "S" the parameter ST_REV is increased by one.
TAG_DESC	W S	Via this parameter the valve interface can be assigned a tag (measuring point designation) within the plant and/or process.
STRATEGY	W S	The strategy field can be used to identify comprising blocks. These data are not controlled or used by the block.
ALERT_KEY	W S	Identification number of the plant unit. This information can be used by the control computer, e.g., to sort alarms. Valid values are 1 ... 65536.
MODE_BLK	W S	Displays the current, allowed normal mode and the target mode of the block. The target mode can be set to the values "Auto" or "Out of Service".
BLOCK_ERR		Displays diagnosis messages of the block.
RS_STATE		Current status of device.
TEST_RW		Test parameter. Is used to test the device.
DD_RESOURCE		FF standard parameter. Not used.
MANUFAC_ID		Identification number of the device manufacturer - is used by the control system to assign the device description (DD) to the device.
DEV_TYPE		Device type - is used by the control system to assign the device description to the device.
DEV_REV		Version number of the device - is used by the control system to assign the device description to the device.
DD_REV		Version number of device description - is used by the control system to assign the device description to the device.
GRANT_DENY	W	Regulates the access rights between control system and local operator's stations for some control systems.
HARD_TYPES		Hardware type.
RESTART	W	Allows to carry out a new manual start. Different types of re-starts are possible: These are: <ul style="list-style-type: none"> <li>• Restart Resource</li> <li>• Restart with defaults (default settings)</li> <li>• Restart processor</li> </ul>
FEATURES		Displays the options supported by the device. These are: Unicode Strings      Unicode string Reports                Alarms Fault State            Release of the safe state for the whole device by the resource block Hard Write lock        Hardware read-only feature Output Readback       Back-reading of the valve position via the PFCs
FEATURE_SEL	W S	The options used are selected here. See FEATURES.

Part No.: 108227, Date of issue 15.02.2013

Parameter	Char	Description
CYCLE_TYPE	.	Gives the different block implementation methods for this device.
CYCLE_SEL	W S	Is used to display the block implementation method.
MIN_CYCLE_T		Shortest macro cycle which can be used by this device.
MEMORY_SIZE		FF standard parameter. Not used.
NV_CYCLE_T		FF standard parameter. Not used.
FREE_SPACE		FF standard parameter. Not used.
FREE_TIME		FF standard parameter. Not used.
SHED_RCAS	W S	Period of time until a communication failure is recognised in the "RCas" mode.
SHED_ROUT	W S	Period of time until a communication failure is recognised in the "ROUT" mode.
FAULT_STATE		Indicates whether or not the device global safety status was set. See SET_FSTATE and CLR_FSTATE.
SET_FSTATE	W S	Is used to set the device global safety status.
CLR_FSTATE	W S	Is used to reset the device global safety status.
MAX_NOTIFY		Maximum number of not acknowledged alarm messages which can be managed by the device.
LIM_NOTIFY	W S	Maximum number of not acknowledged alarm messages which are admitted.
CONFIRM_TIME	W S	Period of time during which an alarm is repeated unless acknowledged.
WRITE_LOCK		Indicates the position of the read-only switch.
UPDATE_EVT		This parameter is used to signal to the control system that a parameter identified by "S" was overwritten if the control system supports alarm messages.
BLOCK_ALM		This parameter is used to signal to the control system diagnosis messages displayed in BLOCK_ERR, if the control system supports alarm messages.
ALARM_SUM		The current status of the alarm messages of the block.
ACK_OPTION	W S	Determines whether or not the alarms of the resource block must be acknowledged.
WRITE_PRI		Priority of the alarm messages which are released when setting and resetting the read-only switch.
WRITE_ALM		Alarm message released when setting and resetting the read-only switch.
ITK_VER		Versions number of interoperability test used to test the device.
SERIAL_NUM		Serial number of device.
SW_REV		Version status of software in device.

## D Glossary

### **Bus segment**

→ Segment

### **Bus termination**

→ Termination resistor

### **Channel**

A channel of the Valve Coupler designates a valve with the two associated PFCs.

### **EMC**

**E**lectromagnetic **c**ompatibility is the ability of an electrical device to function properly in a specified environment without affecting the environment in an undue manner by emitting electromagnetic radiation.

### **FF-H1**

Abbreviation for → FOUNDATION Fieldbus with a data rate of 31.25 kbit/s.

### **Fieldbus Foundation**

Founder organization of the FOUNDATION Fieldbus.

### **FISCO**

Fieldbus Intrinsically **S**afe **C**oncept.

### **FOUNDATION Fieldbus**

Fieldbus of the Fieldbus Foundation. "FF" is a bus system, which networks the FF compatible automation systems and field devices in the cell and field level.

FOUNDATION is a trademark (TM) of the Fieldbus Foundation.

### **PFC**

Final **P**osition **f**eedback **c**ontact. This can be a mechanical switch or a NAMUR sensor.

### **Segment**

A segment or bus segment is a closed part of a serial bus system. The bus line between two termination resistors forms a segment. A segment contains 0 to 32 bus participants. Segments can be coupled via fieldbus repeaters.

### **Power Repeater**

A power repeater from Pepperl+Fuchs combines two separate FF segments. The two segments are coupled with each other in terms of data engineering but separated from each other in relation to the physics of transmission. One of the two segments is powered by the power repeater.

### **TAG**

Clear designation of the control engineering point of the field device within the process plant.

### **Termination resistor**

A termination resistor is a resistor to terminate the data transfer line in order to avoid cable reflections; termination resistors are required in any case at the cable or segment ends.





The general terms of delivery for products and services produced or provided by the electrical industry as published by the Zentralverband Elektrotechnik und Elektroindustrie (ZVEI) e.V. in its most recent edition as well as the supplementary proviso: "Extended property proviso" are applicable.

We at Pepperl+Fuchs feel obligated to contribute to the future;  
this publication is, therefore, printed on paper bleached without the use of chlorine.

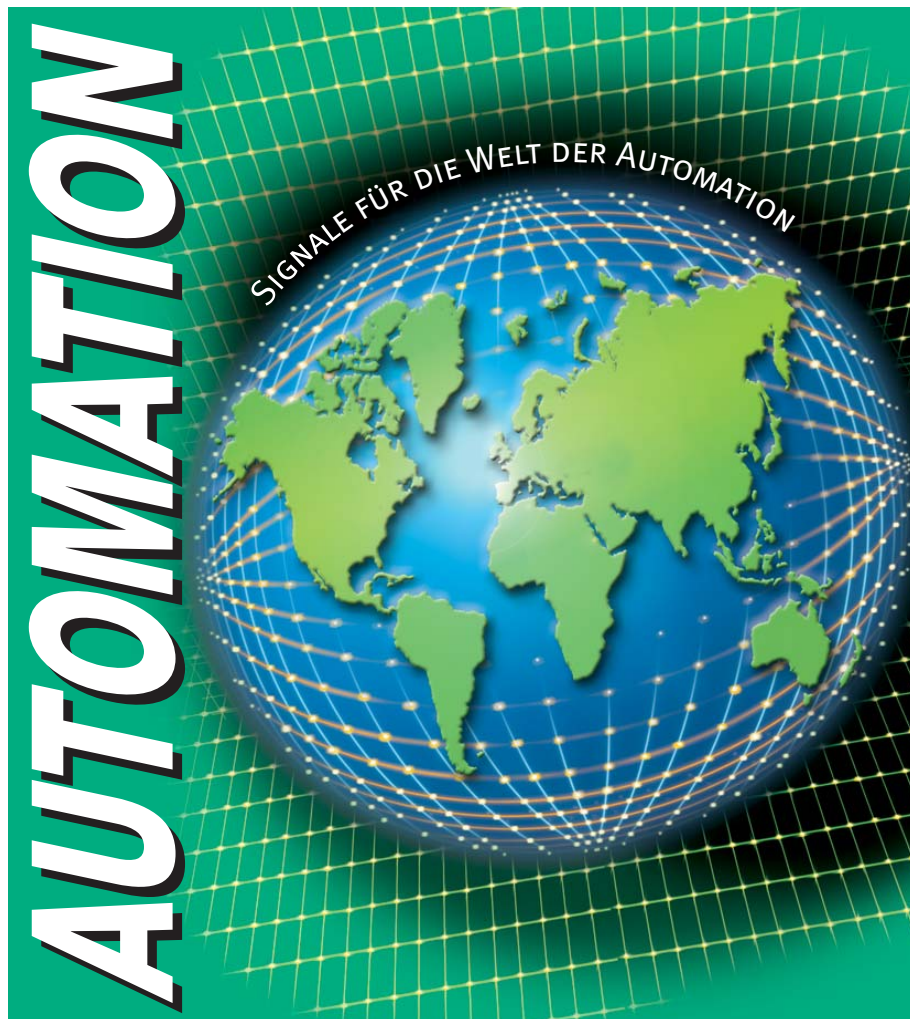

[www.pepperl-fuchs.com](http://www.pepperl-fuchs.com)

Tel. (0621) 776-1111 · Fax (0621) 776-27-1111 · E-Mail: [fa-info@de.pepperl-fuchs.com](mailto:fa-info@de.pepperl-fuchs.com)

**Zentrale weltweit**

Pepperl+Fuchs GmbH · Königsberger Allee 87  
68307 Mannheim · Deutschland  
Tel. 0621 776-0 · Fax 0621 776-1000  
E-Mail: [info@de.pepperl-fuchs.com](mailto:info@de.pepperl-fuchs.com)

**Zentrale Asien**

Pepperl+Fuchs Pte Ltd. · P+F Building  
18 Ayer Rajah Crescent · Singapore 139942  
Tel. +65 67799091 · Fax +65 68731637  
E-Mail: [sales@sg.pepperl-fuchs.com](mailto:sales@sg.pepperl-fuchs.com)

**Zentrale USA**

Pepperl+Fuchs Inc. · 1600 Enterprise Parkway  
Twinsburg, Ohio 44087 · USA  
Tel. +1 330 4253555 · Fax +1 330 4254607  
E-Mail: [sales@us.pepperl-fuchs.com](mailto:sales@us.pepperl-fuchs.com)

 **PEPPERL+FUCHS**  
SIGNALS FÜR DIE WELT DER AUTOMATION