

# MANUAL

## VAA-2E2A-KE1-S/E2, VAA-2E2A-KE1P-S/E2 Original Operating Instructions

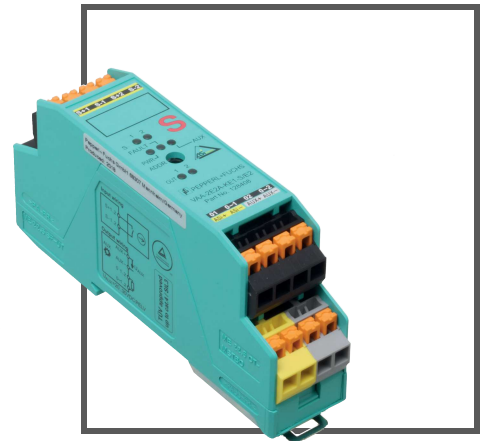

With regard to the supply of products, the current issue of the following document is applicable: The General Terms of Delivery for Products and Services of the Electrical Industry, published by the Central Association of the Electrical Industry (Zentralverband Elektrotechnik und Elektroindustrie (ZVEI) e.V.) in its most recent version as well as the supplementary clause: "Expanded reservation of proprietorship"

<b>1</b>	<b>Introduction.....</b>	<b>5</b>
1.1	Content of this Document .....	5
1.2	Manufacturer .....	5
1.3	Target Group, Personnel.....	5
1.4	Symbols Used .....	6
<b>2</b>	<b>Product Description .....</b>	<b>7</b>
2.1	Intended Use .....	7
2.1.1	Non-Secure Outputs .....	7
2.2	AS-Interface Safety at Work VAA-2E2A-KE1-S/E2 and VAA-2E2A-KE1P-S/E2.....	7
2.3	Peripheral Requirements.....	8
2.4	Connections and Displays .....	8
2.5	Interfaces and Connections.....	9
2.5.1	AS-Interface, Auxiliary Energy .....	9
2.5.2	Inputs .....	10
2.5.3	Outputs .....	10
<b>3</b>	<b>Commissioning.....</b>	<b>12</b>
3.1	Preparation .....	12
3.2	Configuring the AS-Interface Safety Monitor .....	12
3.3	Installation .....	12
3.4	Addressing Modules.....	12
3.5	Operational Testing.....	12
3.6	Operating Mode.....	13
3.7	Operation .....	13
<b>4</b>	<b>Maintenance and Repair .....</b>	<b>14</b>
4.1	Maintenance and Repair.....	14
<b>5</b>	<b>Technical Data.....</b>	<b>15</b>

<b>6</b>	<b>Appendix A</b> .....	<b>18</b>
6.1	Application Examples .....	18
6.2	Category 2.....	18
6.3	Category 3.....	18
6.4	Category 4.....	21
<b>7</b>	<b>Appendix B</b> .....	<b>24</b>
7.1	Summary of the Requirements for Categories in Accordance with EN 954-1/ISO 13849-1 .....	24
7.2	Certificates .....	25
7.3	Probability of Failure on Demand Calculation .....	25
7.4	Transfer Time of the Safety-Relevant Information .....	25

# 1 Introduction

## 1.1 Content of this Document

This document contains information required to use the product in the relevant phases of the product life cycle. This may include information on the following:

- Product identification
- Delivery, transport, and storage
- Mounting and installation
- Commissioning and operation
- Maintenance and repair
- Troubleshooting
- Dismounting
- Disposal



### **Note!**

For full information on the product, refer to the further documentation on the Internet at [www.pepperl-fuchs.com](http://www.pepperl-fuchs.com).

The documentation comprises the following parts:

- This document
- Datasheet

In addition, the documentation may comprise the following parts, if applicable:

- EU-type examination certificate
- EU declaration of conformity
- Attestation of conformity
- Certificates
- Control drawings
- Instruction manual
- Other documents

## 1.2 Manufacturer

Pepperl+Fuchs GmbH Lilienthalstraße 200, 68307 Mannheim, Germany
Internet: <a href="http://www.pepperl-fuchs.com">www.pepperl-fuchs.com</a>

## 1.3 Target Group, Personnel

Responsibility for planning, assembly, commissioning, operation, maintenance, and dismounting lies with the plant operator.

Only appropriately trained and qualified personnel may carry out mounting, installation, commissioning, operation, maintenance, and dismounting of the product. The personnel must have read and understood the instruction manual and the further documentation.

Prior to using the product make yourself familiar with it. Read the document carefully.



## 1.4 Symbols Used

This document contains symbols for the identification of warning messages and of informative messages.

### Warning Messages

You will find warning messages, whenever dangers may arise from your actions. It is mandatory that you observe these warning messages for your personal safety and in order to avoid property damage.

Depending on the risk level, the warning messages are displayed in descending order as follows:



#### ***Danger!***

This symbol indicates an imminent danger.

Non-observance will result in personal injury or death.



#### ***Warning!***

This symbol indicates a possible fault or danger.

Non-observance may cause personal injury or serious property damage.



#### ***Caution!***

This symbol indicates a possible fault.

Non-observance could interrupt the device and any connected systems and plants, or result in their complete failure.

### Informative Symbols



#### ***Note!***

This symbol brings important information to your attention.



#### **Action**

This symbol indicates a paragraph with instructions. You are prompted to perform an action or a sequence of actions.

## 2 Product Description

### 2.1 Intended Use

When used as intended, the AS-Interface safety module allows the operation of sensor-controlled personal protective equipment up to category 4 and PL e as per ISO 13849 or up to SIL 3 as per EN/IEC 61508 and EN/IEC 62061 in combination with an appropriately programmed AS-Interface safety monitor. The safety level of the application is determined either via a risk analysis, e.g., in accordance with EN 1050, or is taken from a C standard.

#### 2.1.1 Non-secure outputs



#### **Warning!**

The outputs must not be used for safety-related functions.

### 2.2 AS-Interface Safety at Work VAA-2E2A-KE1-S/E2 and VAA-2E2A-KE1P-S/E2

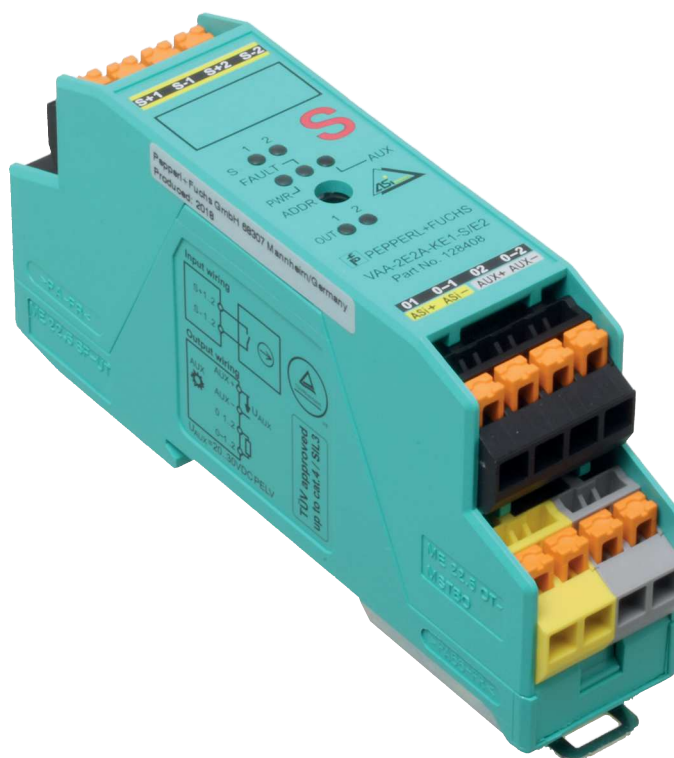

The VAA-2E2A-KE1\*-S/E2 is an AS-Interface safety module with two safety-related inputs and two outputs. A dual-channel mechanical switch can be connected to the two safety-related inputs, or a single-channel mechanical switch can be connected to each input. The outputs are conventional electronic outputs that can have a total load of 1 A (max 0.5 A per output). The housing is only 22.5 mm wide and 48.5 mm tall and takes up little space in the switch cabinet. The module is mounted by snapping it onto the 35 mm DIN rail in compliance with EN 50022. An addressing socket is integrated into the module.

The connection is made via plug-in terminals. A four-way (black) terminal block is used for the inputs. The AS-Interface is connected via a two-way (yellow) terminal block. Each channel has an LED mounted on the top side of the module to display the current switching status. There is an LED for monitoring AS-Interface communication and for displaying that the module has the address 0.

If single-channel force-guided mechanical switches are connected, the module can be upgraded to Performance Level c in accordance with EN ISO 13849-1 if wired appropriately and if the switch is selected accordingly. If a dual-channel force-guided mechanical switch is connected, the module can be upgraded to Performance Level e in accordance with EN ISO 13849-1 if wired appropriately and if the switch is selected accordingly. As per the approval in accordance with IEC 61508 and IEC 62061, a Safety Integrity Level of up to SIL 3 can be reached. Both module inputs are occupied. The two channels belonging to the mechanical switch are monitored for crossed circuits. Each LED displays the voltage of the AS-Interface and the external power supply.

## 2.3 Peripheral Requirements

### Safety Monitor Requirements

The module must only be used as a safety-related slave in an AS-Interface segment with the corresponding AS-Interface safety monitor as intended. The AS-Interface safety monitor must meet the requirements of the "Specification of Safe AS-Interface Transmission" system specification (version 2.01) dated 05/12/2000.

To evaluate a safety-related function in accordance with a safety standard, all components found in the function must be evaluated in accordance with this standard.

The wiring and programming of the safety monitor determine whether or not the required safety function performs correctly. This also applies to the required safety response after a code fault or failure (see also safety monitor documentation). The safety function (including all safety-related sensors) must be checked prior to initial commissioning. The safety monitor PL category or SIL must, as a minimum, comply with the PL category or SIL required by the application.

### Cabling Requirements

The requirements set out in EN/IEC 60204-1 or similar must always be observed. The requirements for the external cabling and selection of connected sensors are based both on the level of functionality to be achieved, and on the required category (ISO 13849-1, EN/IEC 61508, or EN/IEC 62061).

### Switches or Mechanical Contacts

The switches must be positive opening. Combinations of switches that provide an equivalent level of safety (fault behavior analysis) can be used.

## 2.4 Connections and Displays

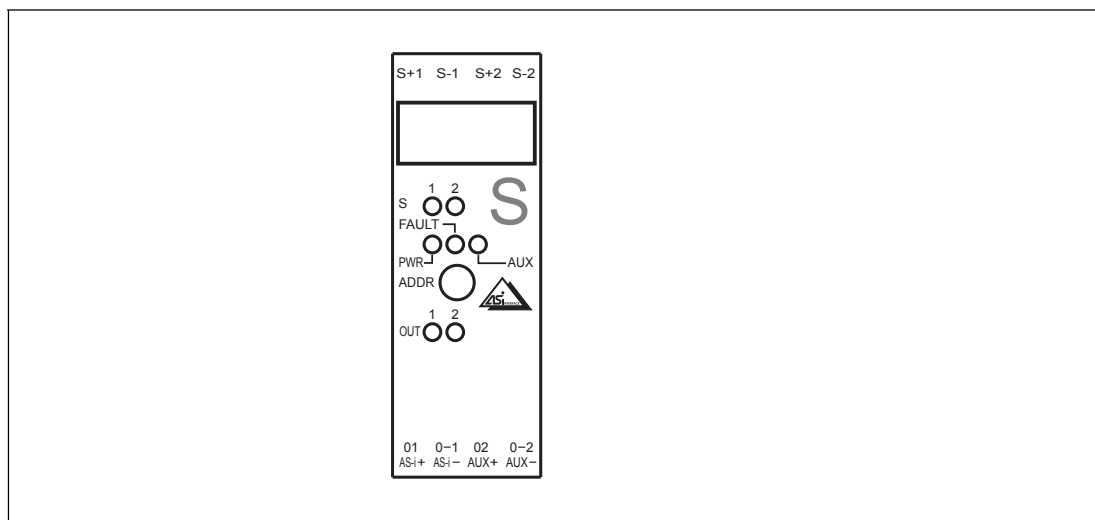

Figure 2.1

130863 2019-04



### Safety related inputs

Designation	Description
S1+	Mechanical switch 1+
S1-	Mechanical switch 1-
S2+	Mechanical switch 2+
S2-	Mechanical switch 2-

### Outputs

Designation	Description
O1	Output 1+
O-1	Output 1-
O2	Output 2+
O-2	Output 2-

### Supply

Designation	Description
ASi+	AS-Interface +
ASi-	AS-Interface -
AUX+	Auxiliary power $U_{AUX}$ +
AUX-	Auxiliary power $U_{AUX}$ -

### Displays

Designation	Description
LED FAULT	Error display; LED red red: communication error or address is 0 red flashing: Output supply overload
LED PWR	AS-Interface voltage; LED green
LED AUX	Ext. auxiliary voltage $U_{AUX}$ ; LED green
LED IN	Switching state (input); 2 LED yellow
LED OUT	Switching state (output); 2 LED yellow

## 2.5 Interfaces and Connections

### 2.5.1 AS-Interface, Auxiliary energy

In case of the KE1-series all interfaces are connected via removable terminals. Thus also AS-Interface and auxiliary energy. The cable has to meet the minimum requirements for AS-Interface (e.g. AS-Interface flat band cable, VAZ-FK-S-YE for AS-Interface and VAZ-FK-S-BK for auxiliary energy).

## 2.5.2 Inputs

### General

The switches are connected to removable terminals. One or more mechanical switches can be connected in series per channel.

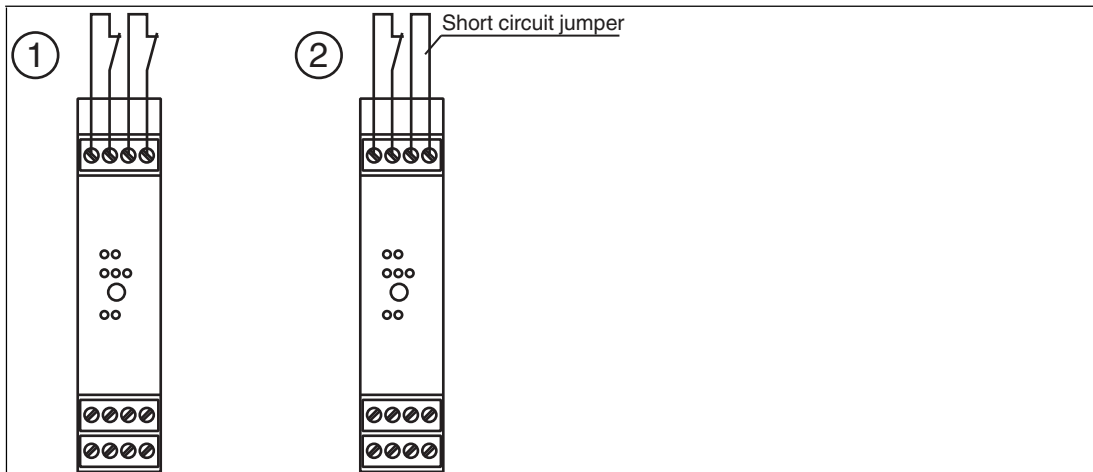

Figure 2.2      ① = 2 mechanical switches (or one two-channel switch)  
                    ② = 1 mechanical switch

If only one single-channel switch is to be used, input 1 should be used in this case. If input 2 is not connected, it must be bridged.

### Safety Category

The module contains two independent and redundant input channels that individually meet the requirements of category 4 in accordance with ISO 13849-1.

### Crossed Circuit Monitoring

The inputs are monitored for inter-crossed circuits. The crossed circuit monitoring function is able to detect low-resistance crossed circuits between the two inputs caused by a metallic connection.

## 2.5.3 Outputs

The outputs are designed according to the AS-Interface standard. These are switched to positive potential (PNP technology).

The outputs can be operated in two modes:

1. The outputs are controlled directly by the corresponding data bits of the AS-Interface master.
2. The output signals of the AS-Interface master are linked with the secure inputs. The outputs are turned on if the master turns them on or if the inputs are in a secure state.

This operating mode is used to control signal lights that must display the state of the inputs without the master being involved.

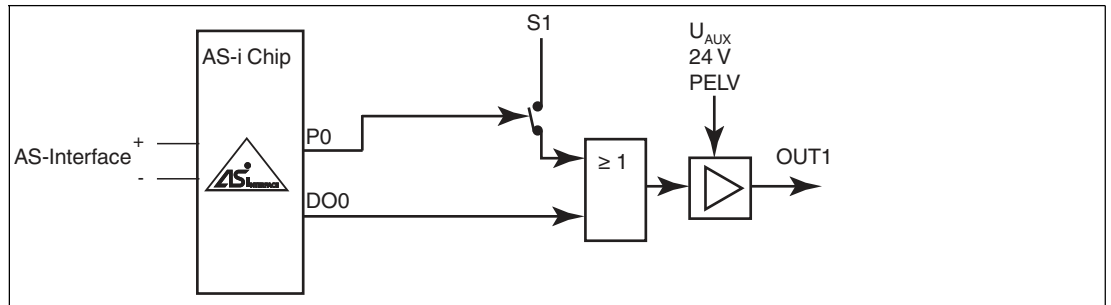

Figure 2.3 Output modes

### Modes and logic table of the outputs

The modes are selected by the Master with parameter bit P0:

P0	S1 S2 <sup>1)</sup>	DO0 DO1 <sup>2)</sup>	OUT1 OUT2	Mode
1	X X	0 0	0 0	Outputs independent of inputs
	X X	1 1	1 1	
0	0 0	X X	1 1	Open switch at the input sets the corresponding output
	1 1	0 0	0 0	When the switches are closed on the input, the master controls the output
	1 1	1 1	1 1	

- 1) 0 = an open switch (secure state).  
1 = closed switch.  
X = any state that has no effect on the outputs.
- 2) 1 = outputs are turned on.  
0 = outputs are voltage-free.

## 3 Commissioning

### 3.1 Preparation



#### Unpacking the device

1. Check the packaging and contents for damage.
  - ↳ In the event of damage, inform the shipping company and notify the supplier.
2. Check the package contents against your order and the shipping documents for completeness and accuracy.
  - ↳ Should you have any questions, direct them to Pepperl+Fuchs.
3. Retain the original packaging in case the device is to be stored or shipped again at a later date.

### 3.2 Configuring the AS-Interface Safety Monitor

For details of necessary organizational measures affecting configuration of the safety monitor, please refer to the documentation for the safety monitor.

#### Safety Classification

The module contains two independent, redundant input channels. If both input channels are used, the module is suitable for use up to category 4/PL e in accordance with ISO 13849-1, or SIL 3 in accordance with EN/IEC 61508 and EN/IEC 62061. In this case, the monitor must be programmed so that dual-channel switching is monitored.

If a single-channel switch is used, the module is suitable for use up to category 2/PL c in accordance with ISO 13849-1, or SIL 1 in accordance with EN/IEC 61508 and EN/IEC 62061. Only tested and certified power supplies with safe isolation may be used to supply power. These power supplies must have PELV voltage in accordance with EN 50295/IEC 62026-2, and a minimum MTBF of 50 years. The power supplies are designed to exclude a short circuit between the primary and secondary sides.

### 3.3 Installation

For installation of the module a suitable top hat DIN rail in accordance with DIN 50022 is recommended.

### 3.4 Addressing modules

Addressing of the module is performed by means of a manual addressing device or with an AS-Interface master. If a manual addressing device is used, it should be connected and addressed to the addressing socket of the module (identified with ADDR) using the addressing cable included with delivery. Addresses from 1 to 31 can be assigned. The state as supplied is address 0.

### 3.5 Operational Testing

Perform function tests as part of the installation by activating the safety function. The operational test uncovers all existing faults at the time of installation. Because the safe inputs are monitored for crossed circuits, it is not necessary to test for short circuits in the cabling.



#### **Note!**

In the case of single-channel safety functions, test the function for each channel.

For applications of category 4/PL e in accordance with ISO 13849-1 or SIL 3 in accordance with EN/IEC 61508 and EN/IEC 62061, the two inputs must be monitored using the safety monitor to ensure that they are synchronous.



### Performing a Function Test

1. Activate the safety function by interrupting the input. This can be done by actuating a connected mechanical switch or on the cable.
2. Check whether the safety monitor detects the interruption without issuing a fault message.
3. Stop the interruption on the input on the connected mechanical switch or on the cable.
4. Enable the input on the safety monitor.

## 3.6

### Operating Mode

Activating operating modes for the inputs is not possible.

The parameters in the AS interface may influence the performance of the outputs. The chapter "Operating principle" contains a more accurate description.

## 3.7

### Operation

Programming the safety monitor parameters defines the safety function of the device. Read the corresponding documentation.



## 4 Maintenance and Repair

### 4.1 Maintenance and repair

Regular function tests may be necessary, depending on the safety category.

## 5 Technical Data

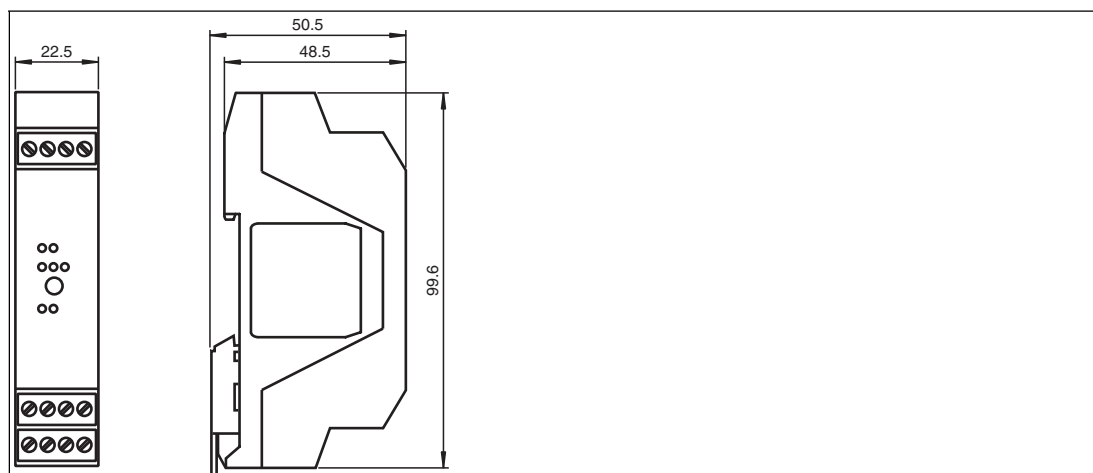

Figure 5.1

### General Data

Slave type	Safety slave
UL file number	E223772

### Functional Safety Data

Safety Integrity Level (SIL)	SIL 3
Performance Level (PL)	PL e
MTTF <sub>d</sub>	200 a
PFH <sub>d</sub>	0
PFD	0

### Indicators/Operating Elements

FAULT LED	Fault indication; LED red Red: communication fault or address is 0 Red, flashing: output voltage overload
PWR LED	AS-Interface voltage; green LED
AUX LED	Ext. auxiliary voltage $U_{AUX}$ ; green LED
IN LED	Switching state (input); 2 yellow LEDs
OUT LED	Switch state (output); 2 yellow LEDs

### Electrical Data

Auxiliary power (output)	20 VDC ... 30 VDC PELV
Rated operating voltage	26.5 V ... 31.6 V from AS-Interface
Rated operating current	$\leq 70$ mA
Protection class	III
Surge protection	$U_{AUX}$ , $U_e$ : Overvoltage category II, securely isolated power supplies (PELV)

**Input**

Number/type	2 safety-related inputs for mechanical contacts, monitored for crossed circuits: 2 single-channel contacts: up to category 2/PL c in accordance with ISO 13849-1 or 1 dual-channel contact: up to category 4/PL e in accordance with ISO 13849-1 Cable length must not exceed 300 m per input.
Power supply	From AS-Interface
Voltage	20 VDC ... 30 VDC, pulsed
Current rating	Input current limited $\leq 15$ mA, overload and short-circuit proof

**Output**

Number/type	2 conventional electronic outputs, PNP
Power supply	From external auxiliary voltage $U_{AUX}$
Current	0.5 A per output
Voltage	$\geq (U_{AUX} - 0.5 \text{ V})$

**Programming Instructions**

Profile	S-7.B	
IO code	7	
ID code	B	
ID1 code	F	
ID2 code	0	
Data bit (function via AS-Interface)	Input	Output
D0	Dyn. security code 1	OUT 1
D1	Dyn. security code 1	OUT 2
D2	Dyn. security code 2	-
D3	Dyn. security code 2	-
Parameter bit (programmable via AS-Interface)	Function	
P0	Output link: P0 = 1 (default setting): The outputs are controlled via the AS-Interface. P0 = 0: The outputs are controlled via the AS-Interface or the inputs. When the contact of an input is opened, the corresponding output is activated.	
P1	Not used	
P2	Not used	
P3	Not used	

**Directive Conformity**

Electromagnetic compatibility	
Directive 2014/30/EU	EN 62026-2:2013 EN 61496-1:2004



**Standard Conformity**

Insulation coordination	EN 50178:1998
Electromagnetic compatibility	EN 61000-6-2:2005, EN 61000-4-5:2005 1 kV asymmetrical, criterion B, EN 61000-6-4:2007
Degree of protection	EN 60529:2000
Fieldbus standard	EN 62026-2:2013
Electrical safety	EN 50178:1998 IEC 60204-1:2007
Emitted interference	EN 61000-6-4:2007
AS-Interface	EN 62026-2:2013
Functional safety	EN ISO 13849-1:2015 up to PL e, IEC 61508:2010 and IEC 62061:2005/A2:2015 up to SIL 3
Standards	NFPA 79:2002

**Ambient Conditions**

Ambient temperature	-25 °C ... 50 °C (-13 °F ... 122 °F)
Storage temperature	-25 °C ... 85 °C (-13 °F ... 185 °F)
Relative humidity	85 %, non-condensing
Climatic conditions	For indoor use only
Operating altitude	≤ 2000 m ASL
Shock and impact resistance	10 g, 16 ms in 6 spatial directions, 1000 shocks
Vibration resistance	0.75 mm 10 Hz ... 57 Hz, 5 g 57 Hz ... 150 Hz, 20 cycles
Degree of pollution	2

**Mechanical Data**

Degree of protection	IP20
Connection	Removable terminals, terminal connection ≤ 2.5 mm <sup>2</sup>
Material	
Housing	PA 66-FR
Mass	80 g
Mounting	DIN mounting rail
Clamping screw tightening torque	0.5 Nm ... 0.6 Nm



## 6 Appendix A

### 6.1 Application Examples



**Note!**

The examples listed here correspond to our understanding of the categories in accordance with ISO 13849-1 and should not be regarded as binding.

### 6.2 Category 2

The safety function(s) must be tested at appropriate intervals of time by the machine control system. Loss of the safety function will be detected by the test. The test intervals must be adjusted to match the application.

Connecting two independent mechanical position switches of Category 2:

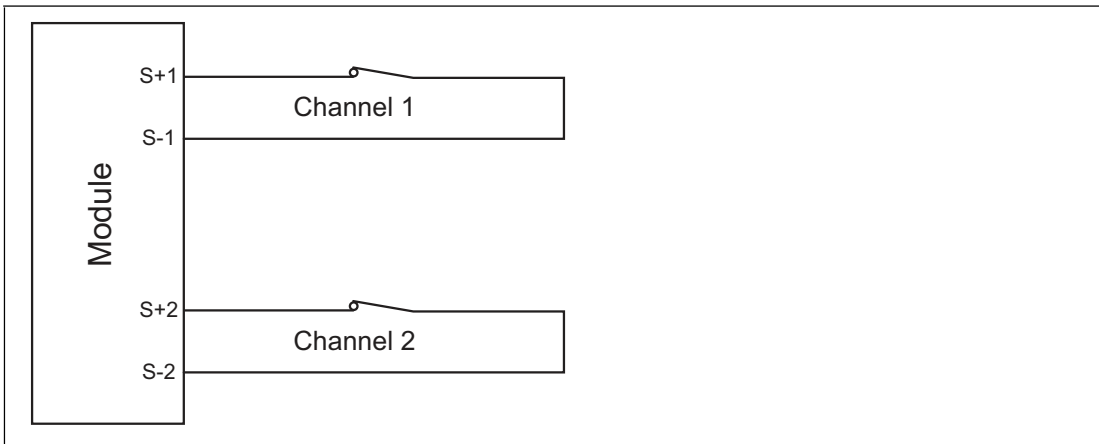

Figure 6.1

### 6.3 Category 3

The occurrence of a fault must not lead to the loss of the safety function.

Connection of two dependent mechanical position switches per channel (two safety functions).

**Example 1:**

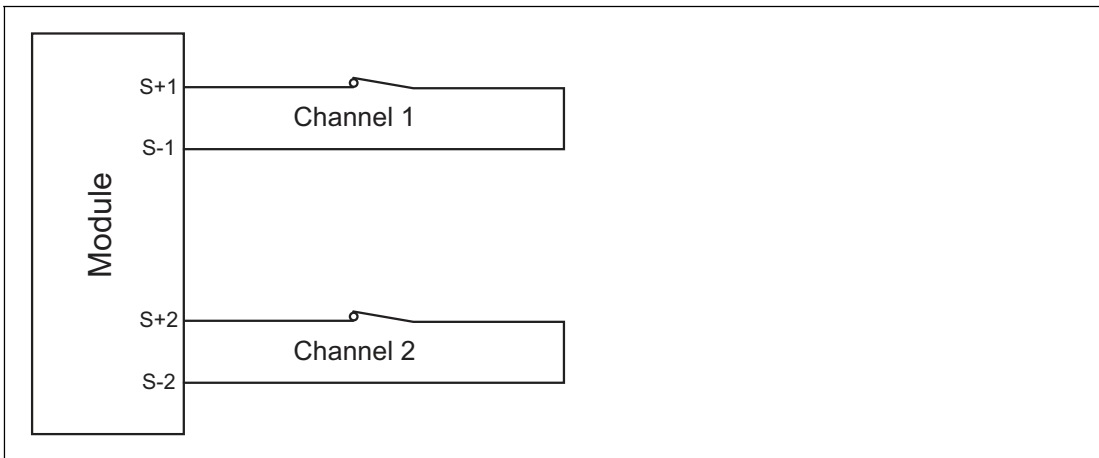

Figure 6.2

**Example 2:**

If a dangerous failure (short circuit) of the switches cannot be excluded, these switches must be duplicated and connected in series.

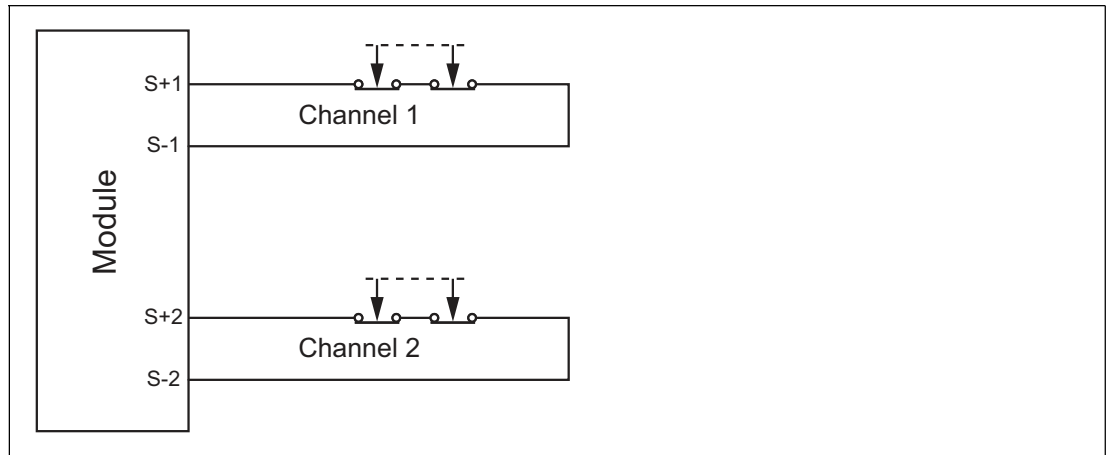

Figure 6.3

**Example 3:**

If a short circuit in the cabling across the switches cannot be excluded, both channels are needed to achieve a category 3 safety function.

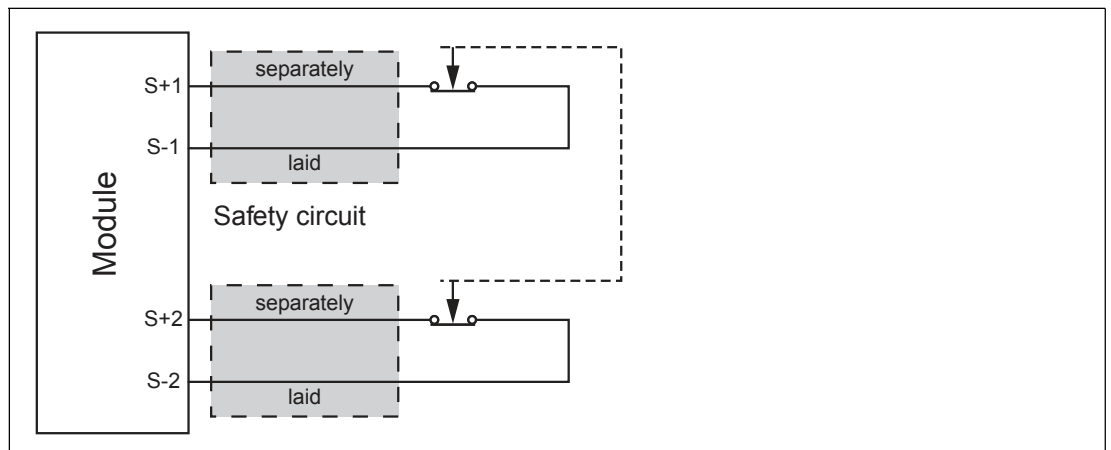
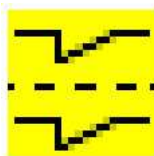

Figure 6.4

The following function blocks can be parameterized to achieve safety category 3 in this application during operation of the AS-Interface safety module on a safety monitor (e.g., VAS-1A-K12 or VAS-2A-K12):

**Examples 1 and 2:**



Dual-channel, independent



**Example 3:**

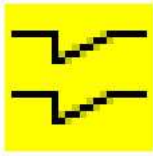

Dual-channel, dependent



Dual-channel, force-guided



**Danger!**

The function block



"Dual-channel, independent" must **not** be used in example 3.

**6.4 Category 4**

The occurrence of a fault and an accumulation of faults must not lead to the loss of the safety function.

**Example 1:**

Connection of a dual-channel mechanical position switch.

To detect a dangerous accumulation of faults, the safety function must be tested. The test intervals must be adapted to the application.

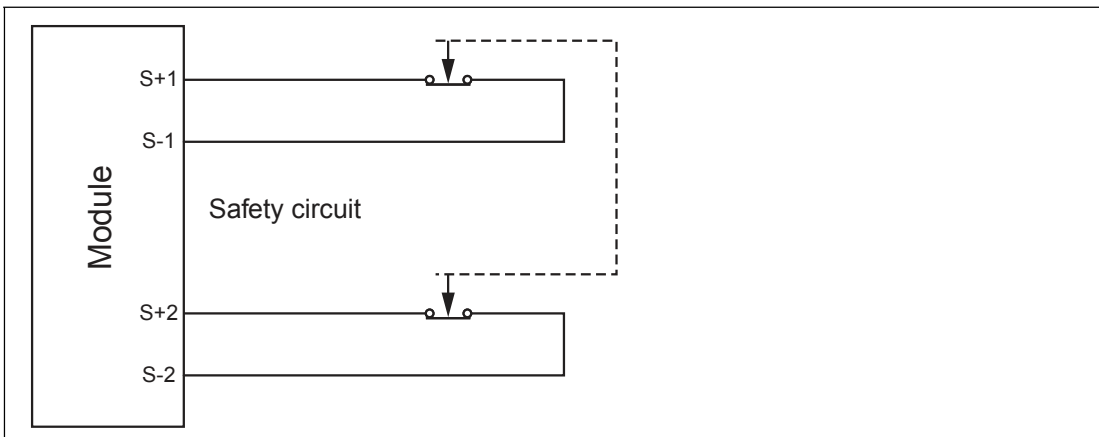

Figure 6.5

### Example 2:

If a dangerous failure (short circuit) of the switch cannot be excluded, two dependent mechanical switches must be used for each channel. To detect a dangerous accumulation of faults, the safety function must be tested. The test intervals must be adapted to the application.

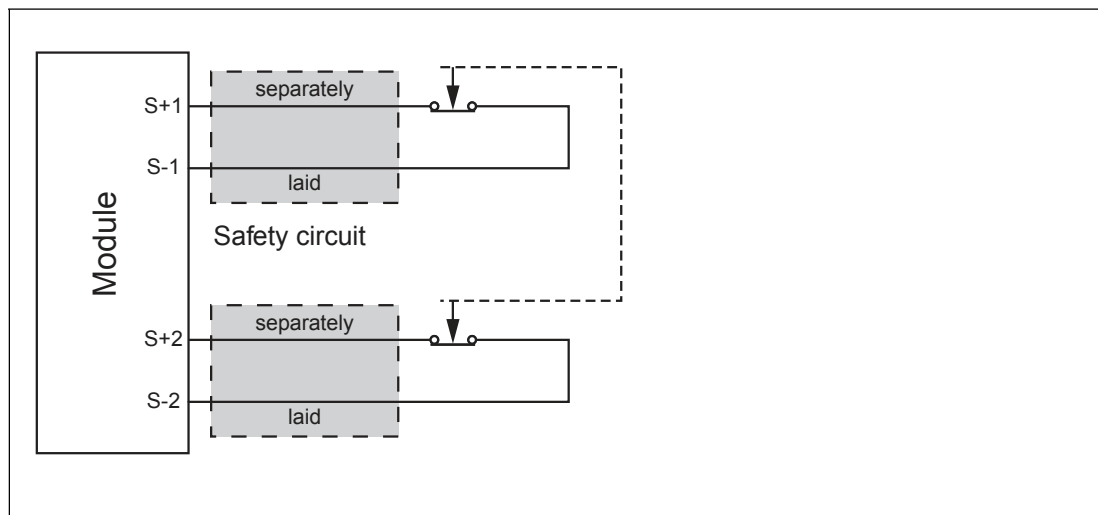
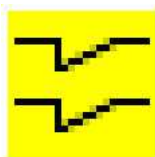
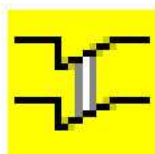

Figure 6.6

The following function blocks can be parameterized to achieve safety category 4 in this application during operation of the AS-Interface safety module on a safety monitor (e.g., VAS-1A-K12 or VAS-2A-K12):



Dual-channel, dependent



Dual-channel, force-guided

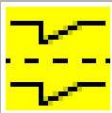

#### **Danger!**

The function block  "Dual-channel, independent" must **not** be used.



#### **Warning!**

The cable length between the module and the sensor is limited to 300 m.

7 Appendix B  
 7.1 Summary of the Requirements for Categories in Accordance with  
 EN 954-1/ISO 13849-1

Category	Summary of the requirement	System behavior <sup>1)</sup>	Essential principle to achieve safety
B	The safety-related parts of machine control and/or their components must be designed, constructed, selected, assembled, and combined in accordance with the applicable standards such that they can withstand the expected influences.	If a fault occurs, it can lead to the loss of the safety function.	Via the selection of components
1	The requirements of B must be fulfilled. Use of components and principles that are proven for safety engineering purposes.	As described for category B, but with the safety function providing a higher level of safety-related reliability.	

Category	Summary of the requirement	System behavior <sup>1)</sup>	Essential principle to achieve safety
2	<p>The requirements of B must be fulfilled and principles that are proven for safety engineering purposes must be used.</p> <p>The safety function(s) must be checked by the machine control at suitable intervals.</p> <p><b>NOTE:</b> What is suitable depends on the application and the type of machine.</p>	<ul style="list-style-type: none"> <li>■ The occurrence of a fault can lead to the loss of the safety function between the test intervals.</li> <li>■ The loss of the safety function is detected by the test.</li> </ul>	Via the structure
3	<p>The requirements of B must be fulfilled and principles that are proven for safety engineering purposes must be used.</p> <p>The control systems must be designed such that:</p> <ul style="list-style-type: none"> <li>■ An individual fault in the control system does not lead to the loss of the safety function, and</li> <li>■ Whenever reasonably practicable, individual faults are detected.</li> </ul>	<ul style="list-style-type: none"> <li>■ When an individual fault occurs, the safety function is always maintained.</li> <li>■ Some, but not all, faults are detected.</li> <li>■ An accumulation of undetected faults can lead to the loss of the safety function.</li> </ul>	
4	<p>The requirements of B must be fulfilled and principles that are proven for safety engineering purposes must be used.</p> <p>The control systems must be designed such that:</p> <ul style="list-style-type: none"> <li>■ An individual fault in the control system does not lead to the loss of the safety function, and</li> <li>■ The individual fault is detected during or before the next time the safety function is invoked. If this is not possible, then an accumulation of faults must not lead to the loss of the safety function.</li> </ul>	<p>When faults occur, the safety function is always maintained.</p> <p>The faults are detected in good time to prevent a loss of the safety functions.</p>	

- 1) The risk assessment indicates whether the complete or partial loss of the safety function(s) due to the occurrence of faults is acceptable.

## 7.2 Certificates

Approvals in accordance with EN/IEC 61508 and EN/IEC 62061.

## 7.3 Probability of Failure on Demand Calculation

To calculate the probability of dangerous failure on demand (PFD) of a safety-related function, the PFD values for all components used within this function must be taken into consideration. In the case of dual-channel applications, the AS-Interface safe input module does not significantly contribute to the PFD or PFH (probability of dangerous failure per hour) of the overall system.

The PFD and PFH values for single-channel application can be found in the data sheet. The PFD or PFH values of the other components, in particular the safety monitor, can be found in the relevant documentation.

## 7.4 Transfer time of the safety-relevant information

The transfer time depends essentially on the monitor. The corresponding documentation and the switch-off times of the actuators must be observed.



# FACTORY AUTOMATION – SENSING YOUR NEEDS



## Worldwide Headquarters

Pepperl+Fuchs GmbH  
68307 Mannheim · Germany  
Tel. +49 621 776-0  
E-mail: [info@de.pepperl-fuchs.com](mailto:info@de.pepperl-fuchs.com)

## USA Headquarters

Pepperl+Fuchs Inc.  
Twinsburg, Ohio 44087 · USA  
Tel. +1 330 4253555  
E-mail: [sales@us.pepperl-fuchs.com](mailto:sales@us.pepperl-fuchs.com)

## Asia Pacific Headquarters

Pepperl+Fuchs Pte Ltd.  
Company Registration No. 199003130E  
Singapore 139942  
Tel. +65 67799091  
E-mail: [sales@sg.pepperl-fuchs.com](mailto:sales@sg.pepperl-fuchs.com)

[www.pepperl-fuchs.com](http://www.pepperl-fuchs.com)

 **PEPPERL+FUCHS**  
SENSING YOUR NEEDS