

K-System Isolated Barriers

System Manual

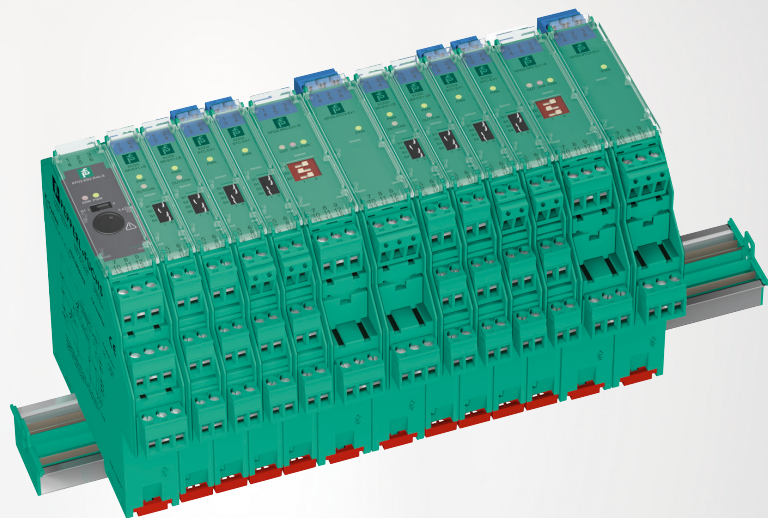

Your automation, our passion.

 **PEPPERL+FUCHS**

With regard to the supply of products, the current issue of the following document is applicable:
The General Terms of Delivery for Products and Services of the Electrical Industry, published by the Central Association of the Electrical Industry (Zentralverband Elektrotechnik und Elektroindustrie (ZVEI) e.V.) in its most recent version as well as the supplementary clause: "Expanded reservation of proprietorship"

Worldwide

Pepperl+Fuchs Group

Lilienthalstr. 200

68307 Mannheim

Germany

Phone: +49 621 776 - 0

E-mail: info@de.pepperl-fuchs.com

North American Headquarters

Pepperl+Fuchs Inc.

1600 Enterprise Parkway

Twinsburg, Ohio 44087

USA

Phone: +1 330 425-3555

E-mail: sales@us.pepperl-fuchs.com

Asia Headquarters

Pepperl+Fuchs Pte. Ltd.

P+F Building

18 Ayer Rajah Crescent

Singapore 139942

Phone: +65 6779-9091

E-mail: sales@sg.pepperl-fuchs.com

<https://www.pepperl-fuchs.com>

1	Introduction	5
1.1	Content of this Document	5
1.2	Target Group, Personnel	6
1.3	Symbols Used	6
2	Product Specifications	7
2.1	Function	7
2.2	Housing Styles	8
2.3	Terminals	11
2.4	Color Identification	15
2.5	Status Indicators of the Isolators	16
2.6	Operating Elements	17
2.7	Label Carrier	19
2.8	DIN Mounting Rail	19
2.9	Power Rail	20
3	Mounting and Installation	21
3.1	Mounting	21
3.2	Connection	26
4	Configuration	35
5	Operation	36
5.1	Fault Monitoring	36
5.2	Fault Output	37
5.3	Current and Voltage Standard Signals	39
6	Dismounting, Maintenance, and Repair	40
6.1	Dismounting the Isolated Barrier	41
7	Technical Specifications	42
7.1	Technical Data	42
7.2	Model Number Description	45
7.3	Dimensions	47

1 Introduction

1.1 Content of this Document

This document contains information that you need in order to use your product throughout the applicable stages of the product life cycle. These can include the following:

- Product identification
- Delivery, transport, and storage
- Mounting and installation
- Commissioning and operation
- Maintenance and repair
- Troubleshooting
- Dismounting
- Disposal



Note

This document does not substitute the instruction manual.



Note

For full information on the product, refer to the instruction manual and further documentation on the Internet at www.pepperl-fuchs.com.



Note

For specific device information such as the year of construction, scan the QR code on the device. As an alternative, enter the serial number in the serial number search at www.pepperl-fuchs.com.

The documentation consists of the following parts:

- Present document
- Instruction manual
- Datasheet

Additionally, the following parts may belong to the documentation, if applicable:

- EU-type examination certificate
- EU declaration of conformity
- Attestation of conformity
- Certificates
- Control drawings
- Functional safety manual
- Additional documents

1.2 Target Group, Personnel

Responsibility for planning, assembly, commissioning, operation, maintenance, and dismantling lies with the plant operator.

Only appropriately trained and qualified personnel may carry out mounting, installation, commissioning, operation, maintenance, and dismantling of the product. The personnel must have read and understood the instruction manual and the further documentation.

Prior to using the product make yourself familiar with it. Read the document carefully.

1.3 Symbols Used

This document contains symbols for the identification of warning messages and of informative messages.

Warning Messages

You will find warning messages, whenever dangers may arise from your actions. It is mandatory that you observe these warning messages for your personal safety and in order to avoid property damage.

Depending on the risk level, the warning messages are displayed in descending order as follows:



Danger!

This symbol indicates an imminent danger.

Non-observance will result in personal injury or death.



Warning!

This symbol indicates a possible fault or danger.

Non-observance may cause personal injury or serious property damage.



Caution!

This symbol indicates a possible fault.

Non-observance could interrupt the device and any connected systems and plants, or result in their complete failure.

Informative Symbols



Note

This symbol brings important information to your attention.



Action

This symbol indicates a paragraph with instructions. You are prompted to perform an action or a sequence of actions.

2 Product Specifications

2.1 Function

Isolated barriers are isolators used for protection of intrinsically safe circuits in hazardous areas. In addition to the required current, voltage and power limitation, the isolated barriers have a galvanic isolation between the field circuit and the controller.

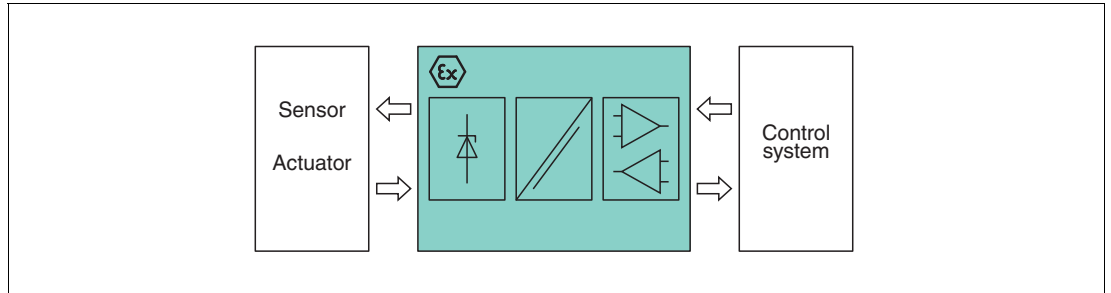

Figure 2.1 Function – isolating, amplifying and transforming signals

The K-System consists of wide range of isolated barriers suitable for mounting on 35 mm DIN mounting rail. K-System is easy to specify, integrate and expand. Our extensive line of intrinsic safe isolators for hazardous location applications contains over 150 different devices.

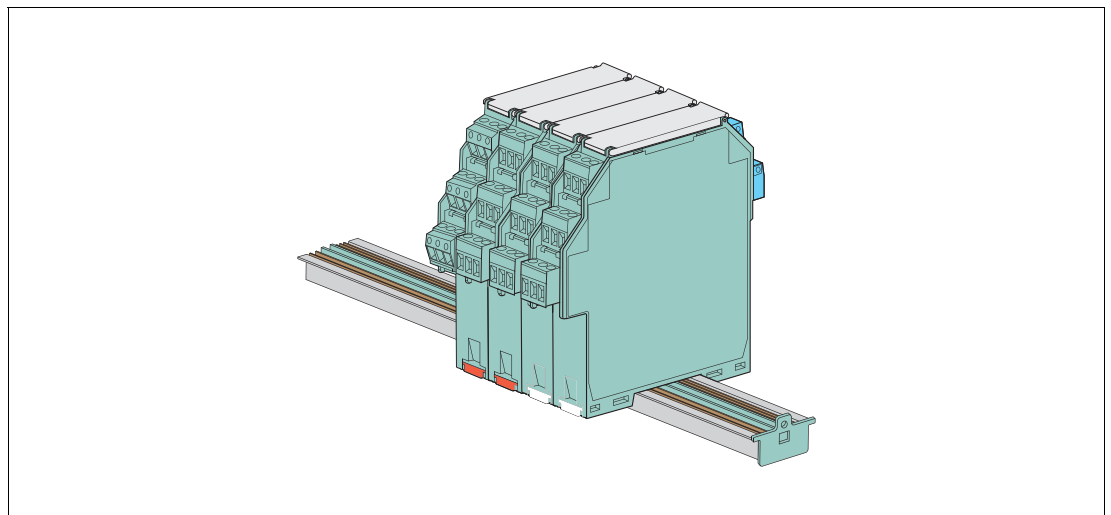

Figure 2.2 K-System on Power Rail

2.2 Housing Styles

Depending on the functionality and application, K-System devices have 3 different housing widths:

- KC devices with 12.5 mm width
- KF devices with 20 mm width
- KF devices or KH devices with 40 mm width

The 3 housing widths versions have the same system characteristics. All devices can be mounted on the 35 mm DIN mounting rail or the Power Rail. See chapter 2.9



Note

See corresponding datasheets for further information.

KC Device Housing

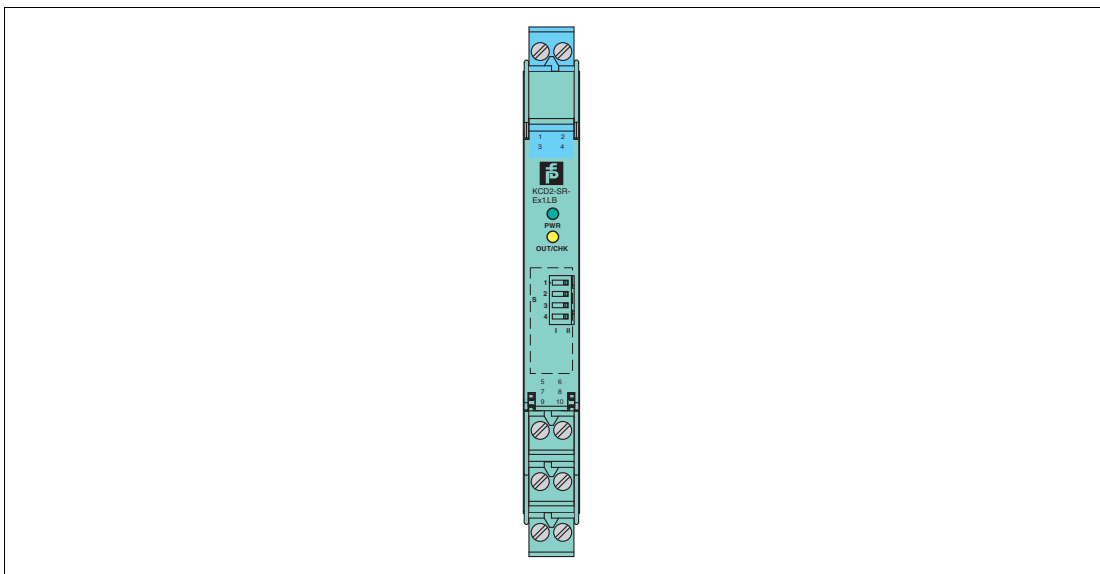

Figure 2.3 KC device housing (12.5 mm)

KF Device Housing

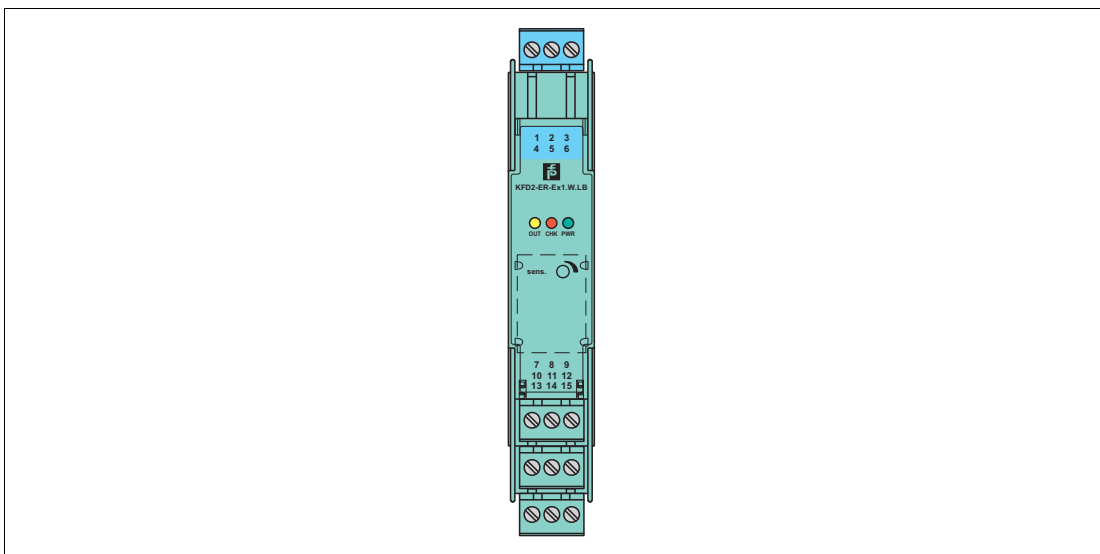

Figure 2.4 KF device housing (20 mm)

DOCT-0187Z 2025-02

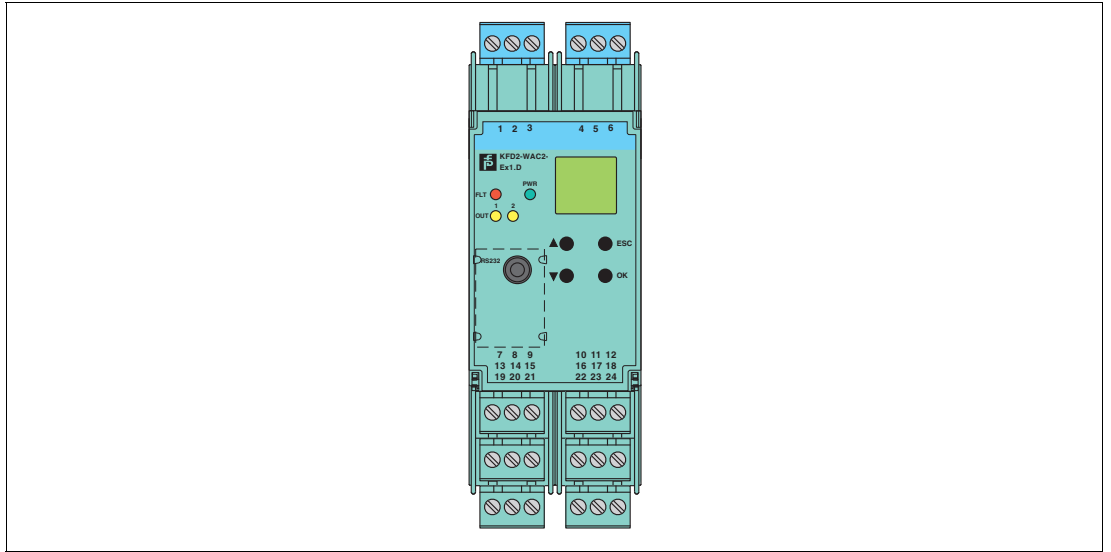

Figure 2.5 KF device housing (40 mm)

Transparent Front Flap

The KC and KF devices have a transparent front flap.

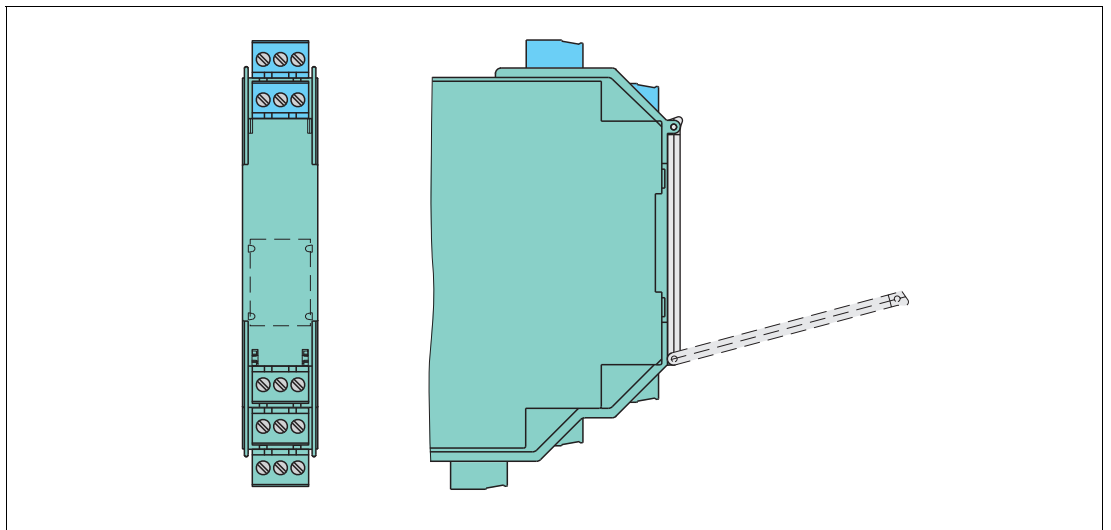

Figure 2.6 Transparent front flap for KC and KF devices, example

This front flap has several functions:

- Protection of the device against electrostatic discharge
- Protection of the operating elements from pollution, see chapter 2.6
- Integrated label carrier for individual labeling, see chapter 2.7

KH Device Housing

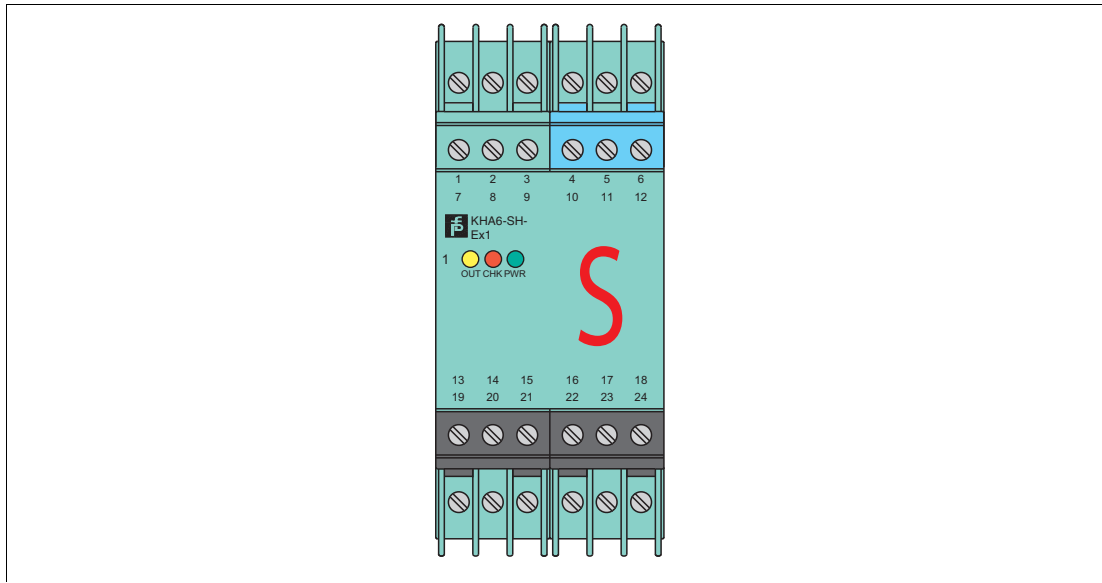

Figure 2.7 KH device housing (40 mm)

2.3 Terminals

2.3.1 Removable Terminal Blocks

The KC and KF devices have removable terminal blocks.

The removable terminal blocks simplify connection and control cabinet assembly. The terminal blocks offer space for the connection of leads with core cross-sections of up to 2.5 mm² (14 AWG). The terminal blocks are coded with red coding pins so misconnection of terminal blocks are eliminated.

Observe the tightening torque of the terminal screws. The tightening torque is 0.5 Nm to 0.6 Nm.

The 20 mm and 40 mm wide KF devices are factory-equipped with screw terminals. The KC devices are available with screw terminals or spring terminals. The order designation of the versions of the KC devices with spring terminals has the extension **.SP**.

As an alternative to the factory-equipped terminal blocks the devices can be used with other terminal blocks:

- Terminal blocks with screw terminals
- Terminal blocks with screw terminals and test plug socket
- Terminal blocks with spring terminals and test plug socket

These terminal blocks are available as accessories. The terminal blocks can be easily coded with KF-CP coding pins (available optionally).

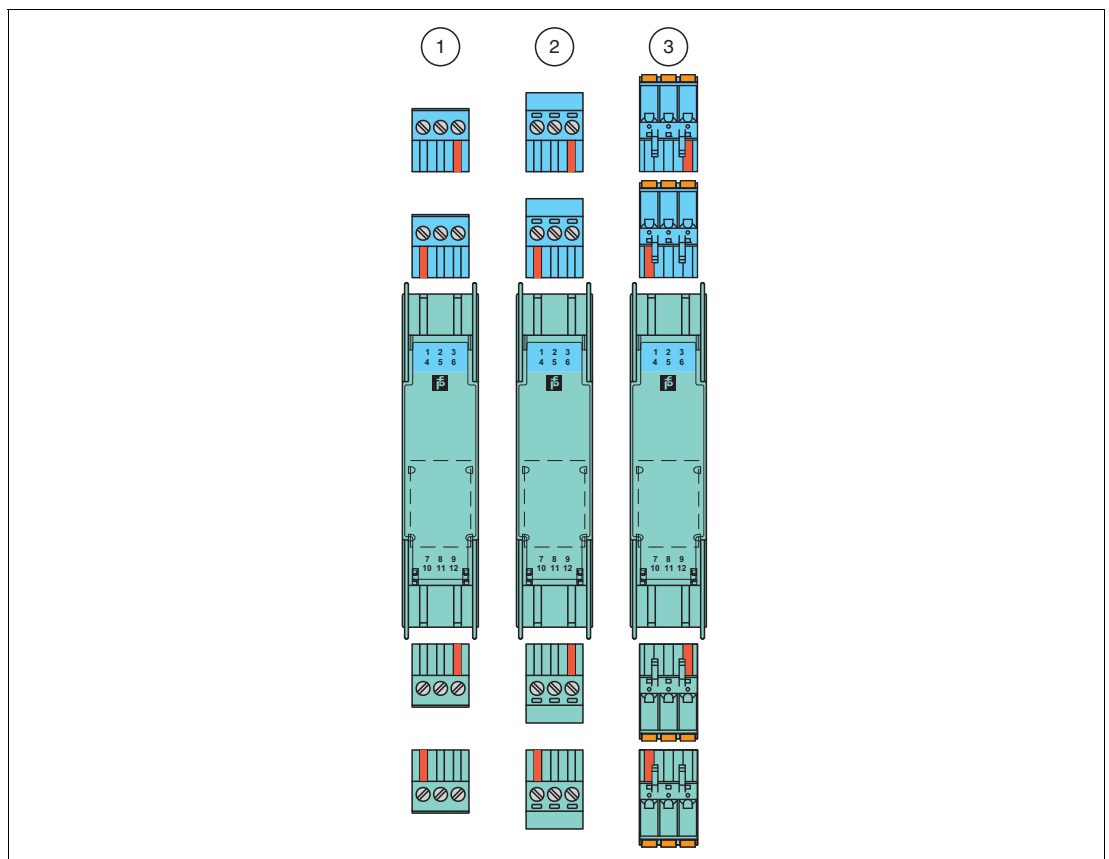

Figure 2.8 K-System removable terminal blocks

- 1 Terminal blocks with screw terminals
- 2 Terminal blocks with screw terminals and test sockets
- 3 Terminal blocks with spring terminals and test sockets

Protection against direct contact

The removable terminal blocks have different heights:

- Height 15 mm (1), (2), (3): These terminal blocks are used in applications that have rated voltages lower than 50 V AC. The insulation of the removable terminal blocks provides protection against direct contact. The insulation corresponds to a reinforced insulation according to EN 61010-1 for a rated insulation voltage of 50 V AC.
- Height 15.5 mm (4), (5): These terminal blocks are used in applications that have rated voltages higher than 50 V AC. The insulation of the removable terminal blocks provides protection against direct contact. The insulation corresponds to a basic insulation according to EN 61010-1 for a rated insulation voltage of 300 V AC. The higher terminals are **X** marked.

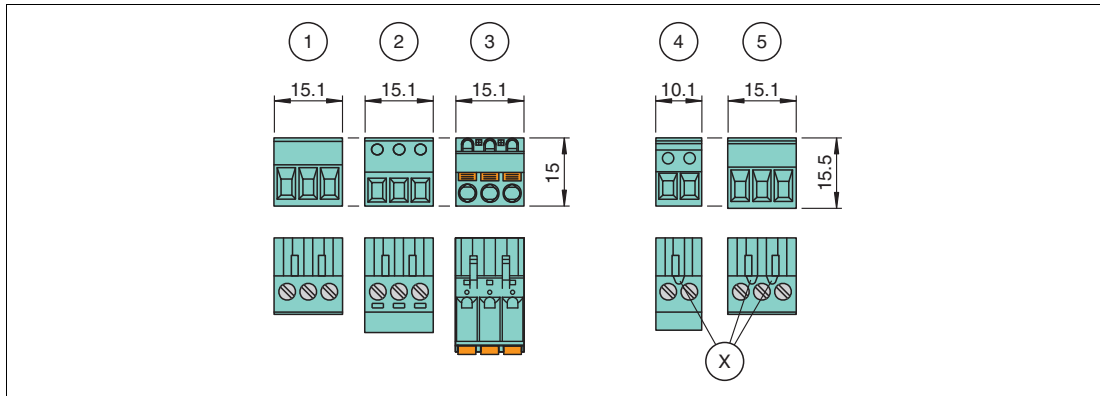

Figure 2.9 Removable terminal blocks with different heights

- 1 Terminal block with screw terminals, height 15 mm
 - 2 Terminal block with screw terminals and test sockets, height 15 mm
 - 3 Terminal block with spring terminals and test sockets, height 15 mm
 - 4 Terminal block with screw terminals and test sockets, height 15.5 mm
 - 5 Terminal block with screw terminals, height 15.5 mm
- X** Marking

Note

See corresponding datasheets for further information.



2.3.2 Terminal Designation



Note

See corresponding datasheets for precise terminal designation.

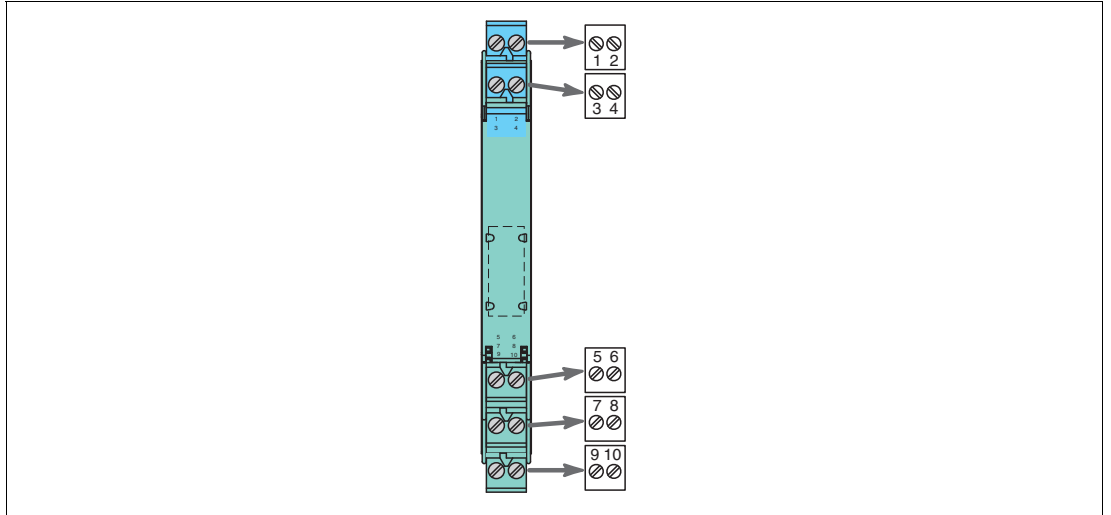

Figure 2.10 KC device housing (12.5 mm)

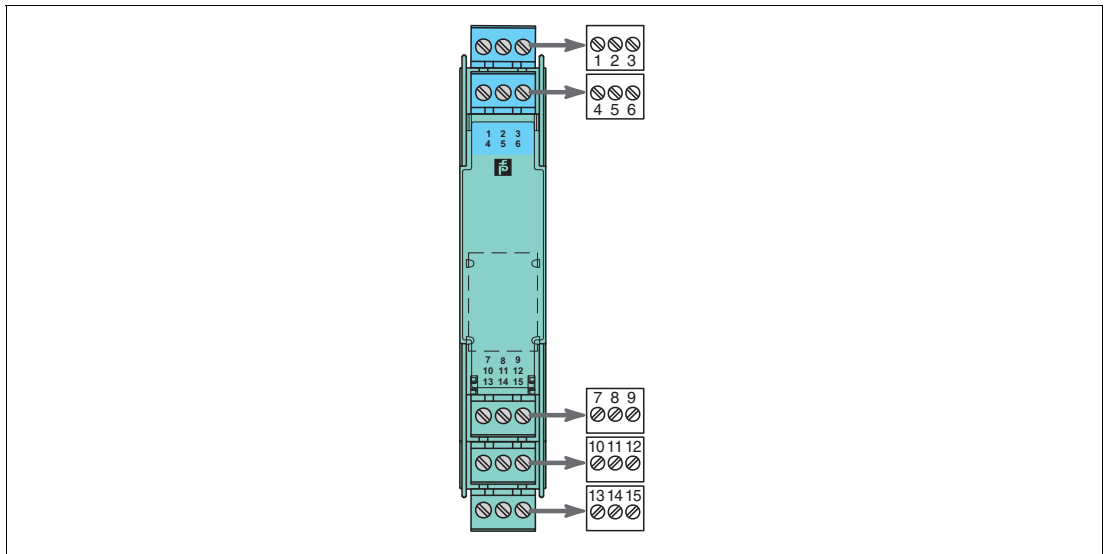

Figure 2.11 KF device housing (20 mm)

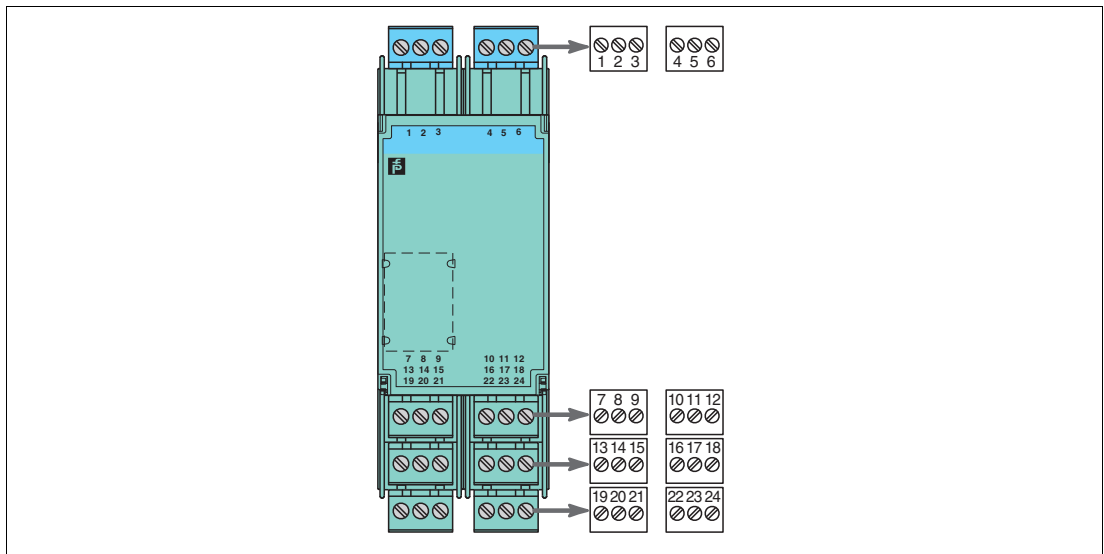

Figure 2.12 KF device housing (40 mm)

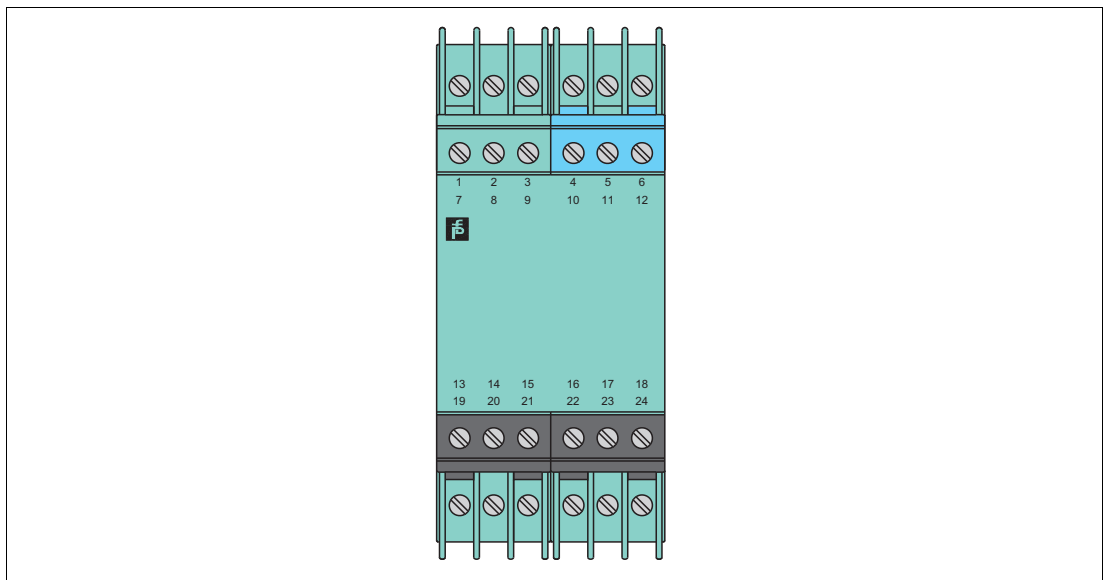

Figure 2.13 KH device housing (40 mm)

2.4 Color Identification

The color identification of the devices has the following meaning:

- Green (1) indicates devices with DC power supply.
- Black (2) indicates devices with AC power supply.
- Gray (3) indicates devices with AC/DC wide range supply.
- Blue (4) indicates devices that process signals from the hazardous area.

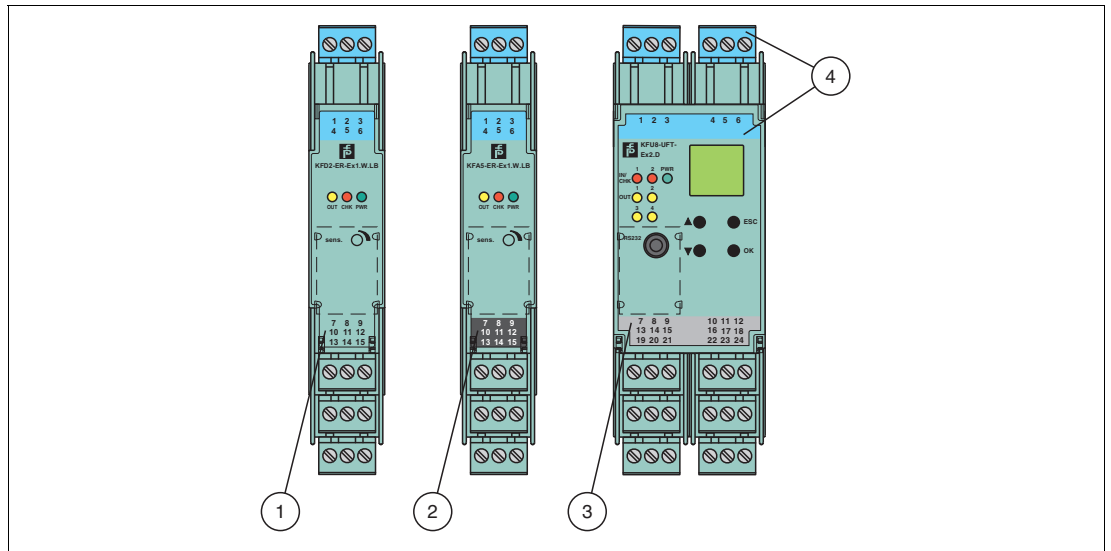

Figure 2.14 Color identification of devices

- 1 green
- 2 black
- 3 gray
- 4 blue

2.5 Status Indicators of the Isolators

LEDs are often used on isolators to indicate different statuses (e. g. for power supply, device failure, status messages, binary switching states). Standard LED colors are assigned to the status display according to NAMUR NE44.

LED	Display function	Display	Meaning
Green LED	Power supply	On	Power supply OK
		Off	No power supply or insufficient power supply – device faulty
Red LED	Device fault, device failure	On	Internal fault signal, failure signal – fault/failure display of causes detected inside the device, device needs replacing
	Line fault	Flashing	External fault signal, failure signal – fault/failure display of causes detected outside the device, inspection and elimination of fault required
	No fault	Off	No malfunction, device is operating properly
Yellow LED	Switching states of binary inputs and outputs	On	Possible causes of the output: <ul style="list-style-type: none"> • The relay is energized. • The NO contact (also a change-over contact) is actively closed. • The open collector is switched through. • The switching voltage generated inside the device is applied. Possible causes of the input: <ul style="list-style-type: none"> • A binary switching signal is present. • An analog limit value is reached.
		Off	Possible causes of the output: <ul style="list-style-type: none"> • The relay is de-energized. • The NO contact (also a change-over contact) is actively opened. • The open collector is not switched through. • The switching voltage generated inside the device is not applied. Possible causes of the input: <ul style="list-style-type: none"> • A binary switching signal is present. • An analog limit value is reached.

Table 2.1 Meaning of status indicators

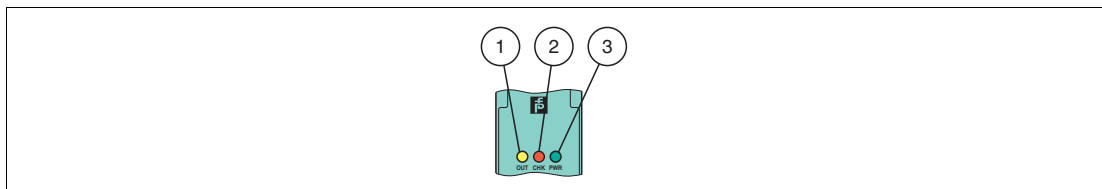

Figure 2.15 Example status indicators

- 1 Yellow LED **OUT****
Switching state of the output
- 2 Red LED **CHK****
Lead breakage and short circuit status indicator
- 3 Green LED **PWR****
Power supply status indicator

2.6 Operating Elements

Many devices of the K-System can be adapted to different applications. Depending on the device different operating elements are available for this configuration.

These operating elements are:

DIP switches

Via DIP switches you can configure the basic functions of the device.

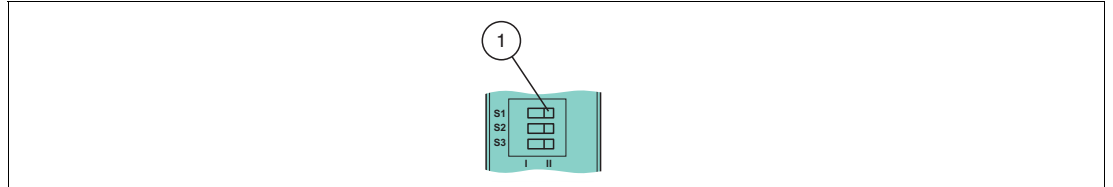

Figure 2.16

- 1 DIP switch

Rotary switches

Via rotary switches you can configure the basic functions of the device.

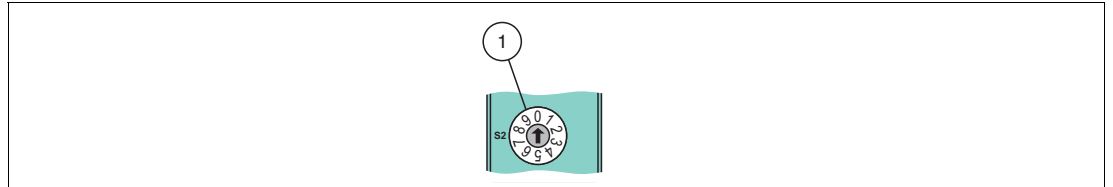

Figure 2.17

- 1 Rotary switch

Potentiometers

Via potentiometers you can configure the calibration of input and output characteristics.

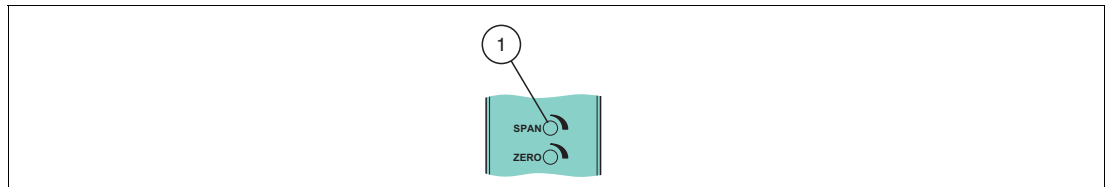

Figure 2.18

- 1 Potentiometer

Keypad and LC display

Via keypad you can configure the settings of the device parameters. Measured values, fault signals and configuration settings are displayed on the LC display.

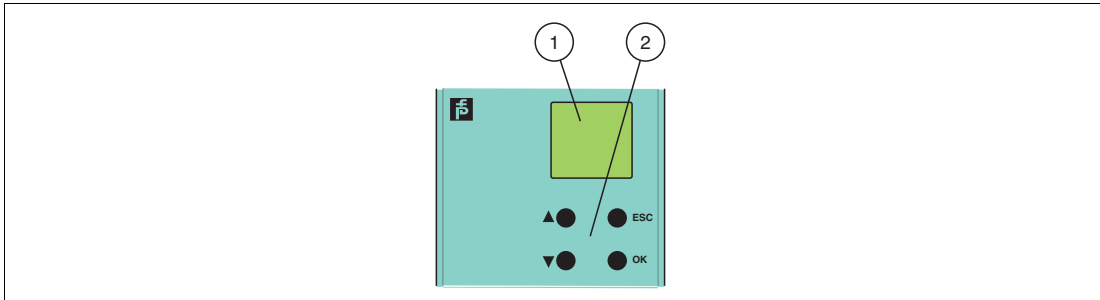

Figure 2.19

- 1 LC display
- 2 Keypad

Programming sockets for the connection of a PC with parameterization software PACTware™

Via parameterization software **PACTware™** you can configure the device easily. The configuration data can be edited and saved. The parameterization software helps users for maintenance, diagnostics and troubleshooting.

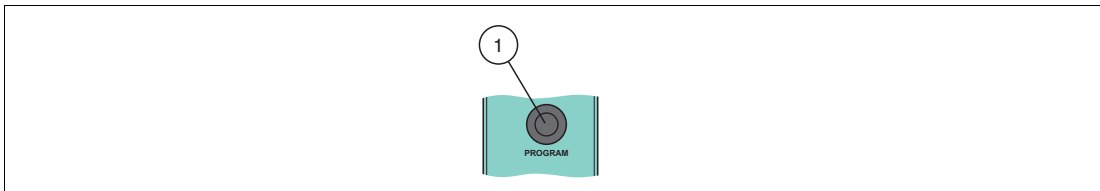

Figure 2.20

- 1 Programming socket



Note

See manual **HART Multiplexer System KFD*-HM*-16** for further information for communication via software.



Note

See corresponding datasheets for further information.

2.7 Label Carrier

For individual labeling, the isolated barriers are equipped ex works with a label carrier. Labels can be inserted into the label carrier.

It is also possible to attach an adhesive label to the transparent front flap.

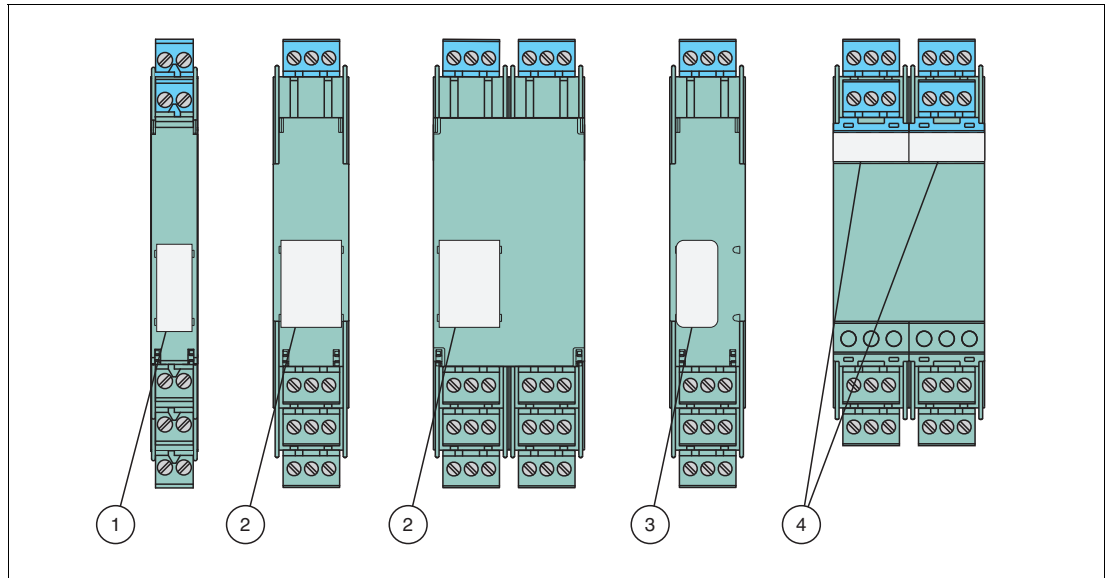

Figure 2.21 Devices with transparent front flap

- 1 Label carrier on KC devices with 22 mm x 9 mm label
- 2 Label carrier on KF devices with 22 mm x 16.5 mm label
- 3 Adhesive label 22 mm x 11 mm for all KC and KF devices, can only be used on devices with a transparent front flap
- 4 Label carrier on KF devices with 18 mm x 8 mm label, can only be used on devices without a transparent front flap

2.8 DIN Mounting Rail

The devices are mounted on a 35 mm DIN mounting rail according to EN 60715.

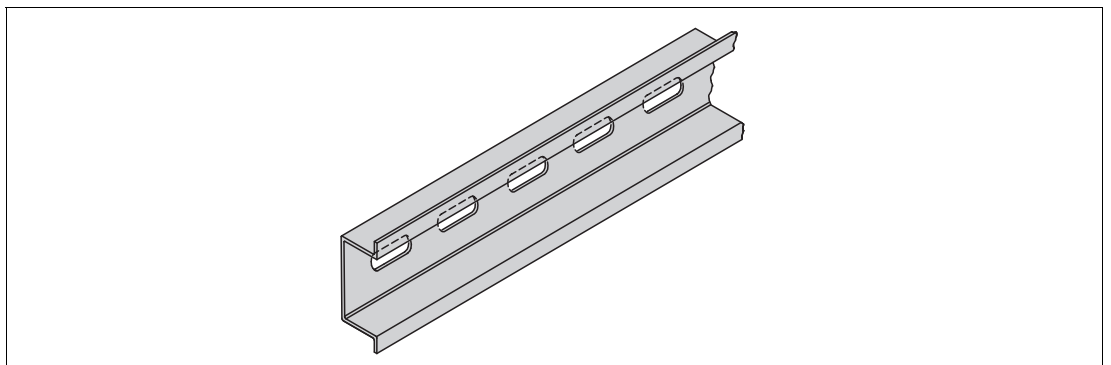

Figure 2.22 Example: DIN mounting rail UPR-MR (35 mm x 15 mm)

2.9 Power Rail

To reduce wiring and installation costs, Power Rail is the optimum solution. The Power Rail is a DIN mounting rail with plastic insert, that delivers power to the devices (24 V DC) and transfers bus signals and a collective error message.

The Power Rail is factory-equipped with cover and end caps. These parts cover empty and open segments of the Power Rail. Thus, the Power Rail is protected from contamination. Additionally the cover and end caps prevent that electrically conductive parts come in contact with the Power Rail.

Power Rail is available in two versions:

Power Rail UPR-03

The Power Rail UPR-03 has 3 conductors.

- 2 conductors for power
- 1 conductor for collective error messaging

Power Rail UPR-05 (only for KFD2-WAC2-(Ex)1.D)

The Power Rail UPR-05 has 5 conductors.

- 2 conductors for power
- 1 conductor for collective error messaging
- 2 conductors for serial data exchange

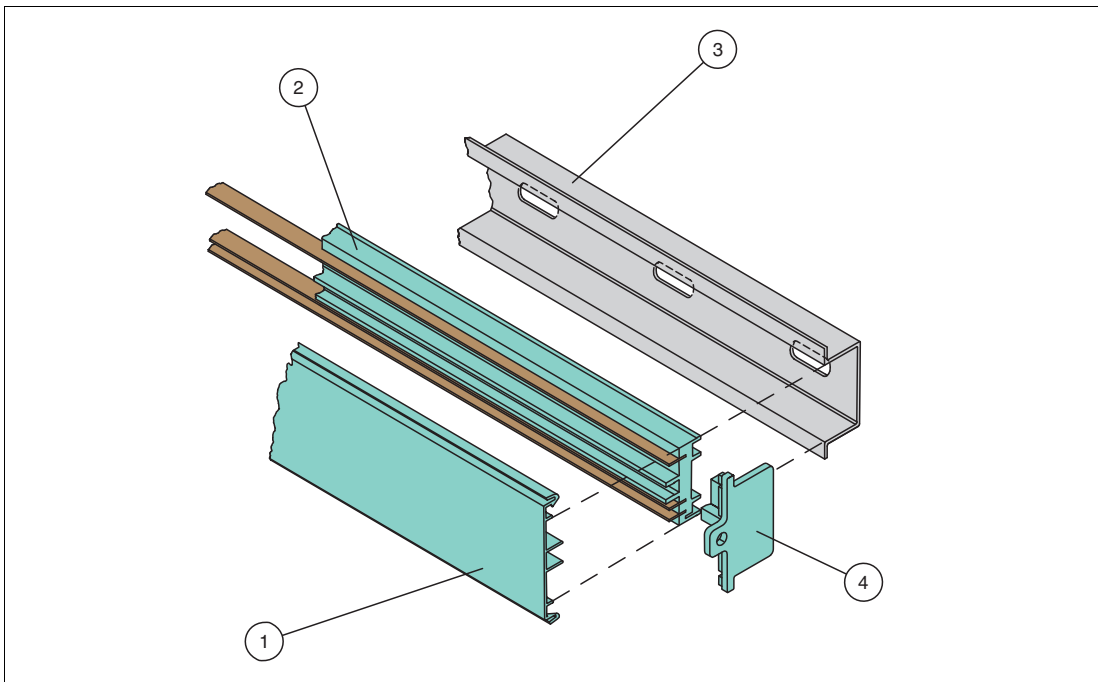

Figure 2.23 Example: Power Rail UPR-03

- 1 Cover UPR-COVER
- 2 Insert UPR-INS-03
- 3 DIN mounting rail UPR-MR (35 mm x 15 mm)
- 4 End cap UPR-E

3 Mounting and Installation



Danger!

Explosion hazard from damaged electronic components

Premature wear of electronic components in a device that was previously used in a general electrical installation can cause sparks that can ignite the surrounding potentially explosive atmosphere.

Never install devices that have already been operated in general electrical installations in electrical installations used in combination with hazardous areas!



Danger!

Explosion hazard from pollution

An excessively polluted surface of the device can become conductive and consequently ignite a surrounding potentially explosive atmosphere.

Ensure that you install the device only in environments with a pollution degree 2 or better according to IEC/EN 60664-1.

3.1 Mounting



Danger!

Danger to life from electric shock

Absent or insufficient insulation can result in electric shock.

Only connect supplies that provide protection against electric shock to power feed modules (e. g. SELV or PELV).



Caution!

Property damage from use of isolators for Power Rail supply

Using the isolators for Power Rail supply can damage the isolators and make the Power Rail fail.

Do not supply the Power Rail via isolators.

Mounting in the Non-Hazardous Area



Mounting the Isolated Barrier

Snap the device onto the DIN mounting rail in a **vertical downward** movement. See following figure.

Mounting in Areas that Require the Equipment Protection Level Gc



Danger!

Explosion hazard from live wiring of non-intrinsically safe circuits

If you connect or disconnect energized non-intrinsically safe circuits in a potentially explosive atmosphere, sparks can ignite the surrounding atmosphere.

Only connect or disconnect energized non-intrinsically safe circuits in the absence of a potentially explosive atmosphere.



Danger!

Explosion hazard from wrong mounting

The device safety can be impaired by external environmental influences and by mechanical stress. That can lead to sparking that can ignite a surrounding potentially explosive atmosphere.

Mount the device in a surrounding enclosure that complies with IEC/EN 60079-0 and that is rated with the degree of protection IP54 according to IEC/EN 60529.



Mounting the Isolated Barrier

Snap the device onto the DIN mounting rail in a **vertical downward** movement. See following figure.

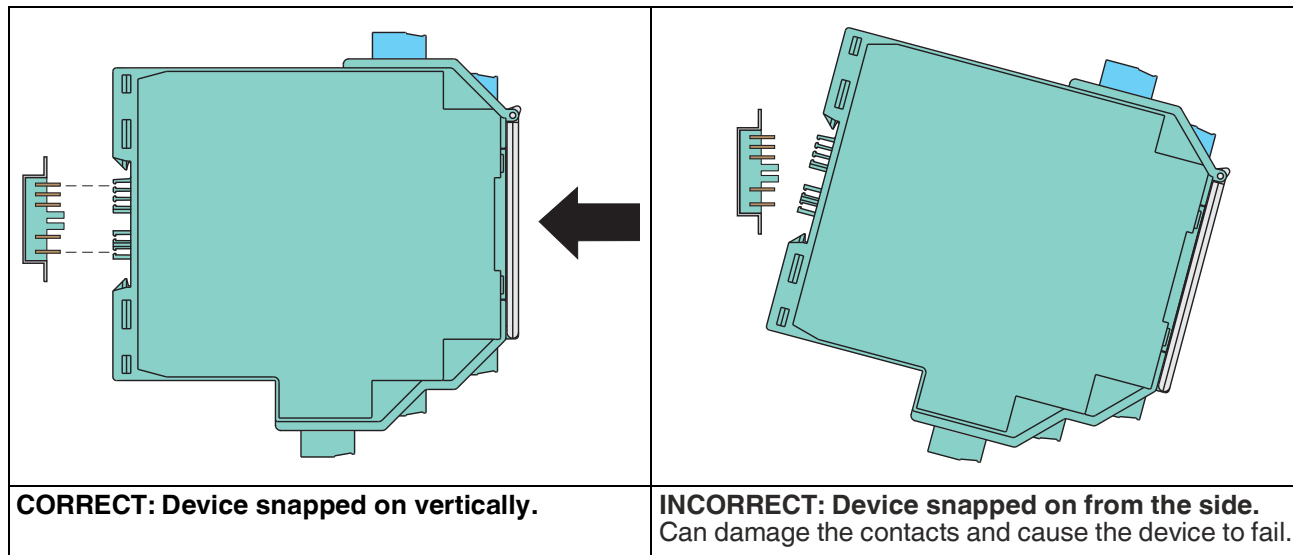

Figure 3.1

Vertical and horizontal mounting

Low heat dissipation allows vertical or horizontal mounting without separation distance. Operation is guaranteed over the full temperature range of the system in any mounting direction and without restriction.

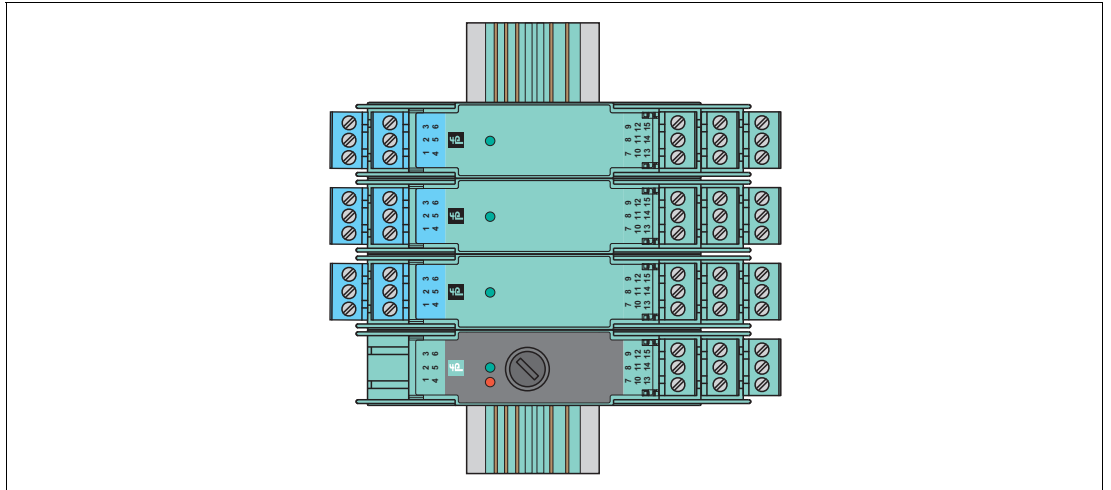

Figure 3.2 Vertical mounting without separation distance (group mounting)

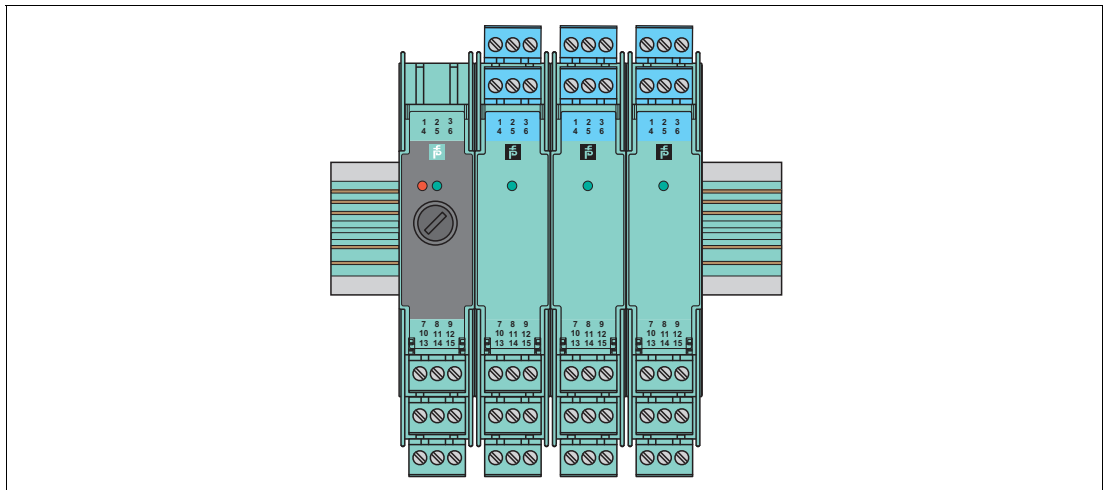

Figure 3.3 Horizontal mounting without separation distance (group mounting)

Mounting Conditions for Operating the Device at Higher Ambient Temperature

Certain devices with a maximum allowable ambient temperature of 60 °C (140 °F) can be operated at ambient temperatures up to 70 °C (158 °F) if mounted horizontally at an appropriate distance, see following figures. These devices have a corresponding reference to this manual in the datasheet.



Caution!

Device failure due to overlooking heat dissipation

Overlooking heat dissipation can compromise the function and the electrical safety of the device.

- Mount the device on the DIN mounting rail in a horizontal mounting position.
- Mount the device on the DIN mounting rail according to the specified minimum separation distance.
- Do not operate devices without this reference in the datasheet at an ambient temperature up to 70 °C (158 °F).



Mounting the Isolated Barriers with Separation Distance

Mount the device on the DIN mounting rail. Observe the specified minimum separation distance. See following figures.

- KC devices with 12.5 mm housing width, housing type A*: min. 6 mm
- KF devices with 20 mm housing width, housing type B*: min. 10 mm
- KF devices with 40 mm housing width, housing type C*: min. 15 mm

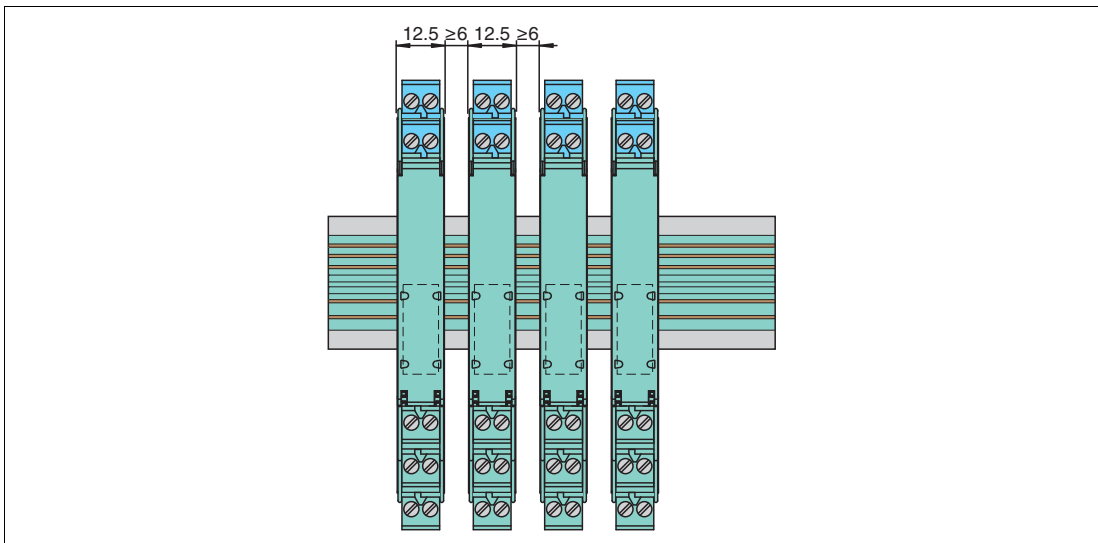

Figure 3.4 Horizontal mounting of KC devices with 12.5 mm housing width (single device mounting)

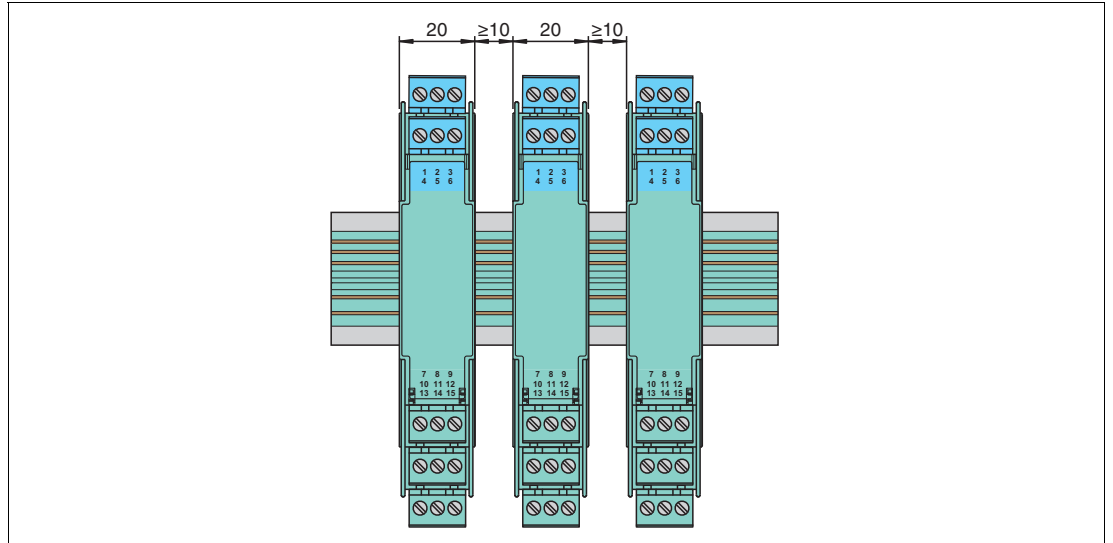

Figure 3.5 Horizontal mounting of KF devices with 20 mm housing width (single device mounting)

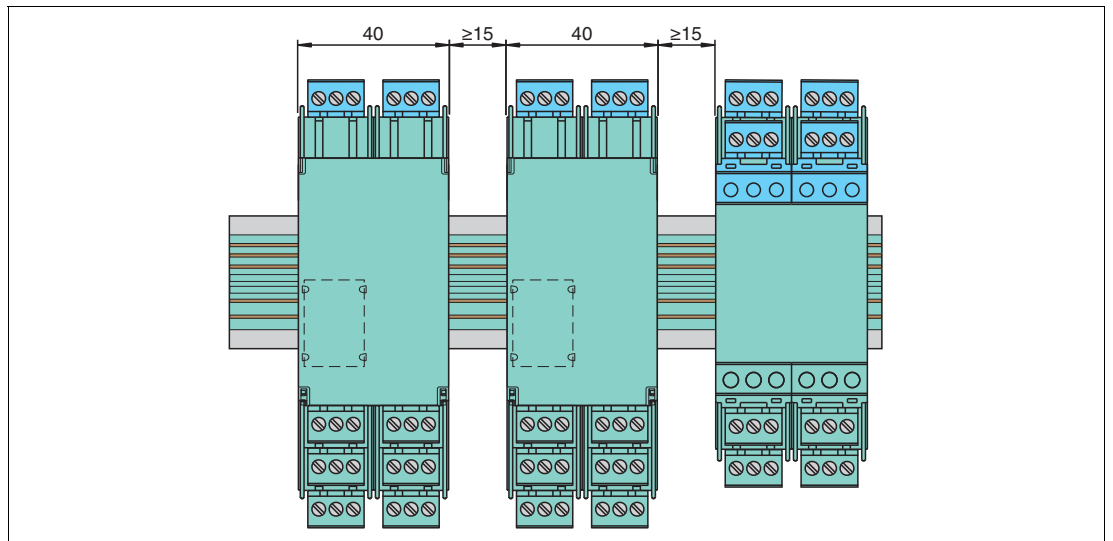

Figure 3.6 Horizontal mounting of KF devices with 40 mm housing width (single device mounting)



Mounting the Terminal Blocks



Danger!

Danger to life from electric shock

Working on live parts at voltages higher than 50 V AC or 120 V DC can result in electric shock.

1. De-energize the device.
 2. Secure the circuit against reconnection.
 3. Verify that the device is de-energized at all poles.
 4. Provide protection from adjacent live parts, if present.
-

1. Switch off the voltage.
2. Connect the terminal blocks or disconnect the terminal blocks.

3.2 Connection



Danger!

Explosion hazard from live wiring of non-intrinsically safe circuits

If you connect or disconnect energized non-intrinsically safe circuits in a potentially explosive atmosphere, sparks can ignite the surrounding atmosphere.

Only connect or disconnect energized non-intrinsically safe circuits in the absence of a potentially explosive atmosphere.



Danger!

Danger to life from electric shock

Absent or insufficient insulation can result in electric shock.

- Maintain sufficient distance between the connection lines, terminals, surrounding enclosure, and the environment.
 - Insulate connection lines, terminals, and the surrounding enclosure from the environment.
-



Danger!

Danger to life from incorrect installation

Incorrect installation of cables and connection lines can compromise the function and the electrical safety of the device.

- Observe the permissible core cross section of the conductor.
 - When using stranded conductors, crimp wire end ferrules on the conductor ends.
 - Use only one conductor per terminal.
 - When installing the conductors the insulation must reach up to the terminal.
 - Observe the tightening torque of the terminal screws.
-



Danger!

Explosion hazard from exposed conductors

Exposed conductors of inadequately attached cables can cause sparks that can ignite the surrounding potentially explosive atmosphere.

When installing the device ensure that the cables are adequately attached.



Caution!

Property damage from use of inappropriate tool

Using an inappropriate tool may damage the screw heads.

- Use a slot-head screwdriver with a size of 3.5 x 0.5.
 - Observe the tightening torque of the terminal screws. The tightening torque is 0.5 Nm to 0.6 Nm.
-



Note

See corresponding datasheets for further information.

3.2.1

Field Side Connection



Danger!

Explosion hazard from wrong separation distances

If you do not observe the minimum separation distance between 2 intrinsically safe circuits, this can lead to added currents or voltages. This can result in a current/voltage flashover generating sparks. The sparks can ignite the surrounding potentially explosive atmosphere.

Ensure that you observe all separation distances between 2 adjacent intrinsically safe circuits according to IEC/EN 60079-14.



Danger!

Explosion hazard from wrong separation distances

If you do not observe the minimum separation distances between intrinsically safe circuits of associated apparatus and non-intrinsically safe circuits, this can lead to added currents or voltages. This can result in a current/voltage flashover generating sparks. The sparks can ignite the surrounding potentially explosive atmosphere.

Ensure that you observe the compliance of the separation distances to all non-intrinsically safe circuits according to IEC/EN 60079-14.



Connecting the Field Side

Connect the field devices via the screw terminals or spring terminals.

3.2.2 Control Side Connection

Connection of Devices with Relay Output

**Danger!**

Danger to life from electric shock

Working on live parts at voltages higher than 50 V AC or 120 V DC can result in electric shock.

1. De-energize the device.
 2. Secure the circuit against reconnection.
 3. Verify that the device is de-energized at all poles.
 4. Provide protection from adjacent live parts, if present.
-

**Warning!**

Risk of short circuit

Live working can cause injuries to the operator and/or damage to the device.

Disconnect the device, before you plug or unplug the plugs.

Connection of other Devices

**Danger!**

Danger to life from electric shock

Absent or insufficient insulation can result in electric shock.

Only connect circuits that provide protection against electric shock (e. g. SELV or PELV).

**Warning!**

Risk of short circuit

Live working can cause injuries to the operator and/or damage to the device.

Disconnect the device, before you plug or unplug the plugs.



Connecting the Control Side

Connect the control system via the screw terminals or spring terminals.

3.2.3 Power Supply Connection

The devices are available with different supply voltages.

- 24 V DC power supply
- 115 V AC or 230 V AC power supply for applications where direct current is not available
- AC/DC wide range supply with 24 V DC or 115/230 V AC



Note

The supported supply voltage for each device is identified on the side plate.

The devices are supplied with power in various ways.

- Power supply without Power Rail, see chapter 3.2.3.1
- Power supply with Power Rail, see chapter 3.2.3.2
 - Non-redundant supply with power feed module
 - Redundant supply with power feed module
 - Direct supply with power supply

3.2.3.1 Power Supply without Power Rail

If devices with AC or universal power supplies are used, the advantages of Power Rail are not available.

Conventional power supplies create complicated and expensive wiring systems.

After all isolated barriers are connected, there is a significant amount of wiring and more wiring must be added for extra functions such as line fault detection.

Connection of KCD and KFD Devices



Danger!

Danger to life from electric shock

Absent or insufficient insulation can result in electric shock.

Only connect supplies that provide protection against electric shock (e. g. SELV or PELV).

Connection of KFA, KFU, and KHA Devices



Danger!

Danger to life from electric shock

Working on live parts at voltages higher than 50 V AC or 120 V DC can result in electric shock.

1. De-energize the device.
2. Secure the circuit against reconnection.
3. Verify that the device is de-energized at all poles.
4. Provide protection from adjacent live parts, if present.



Connecting the Power Supply

Connect the power supply via the screw terminals or spring terminals.

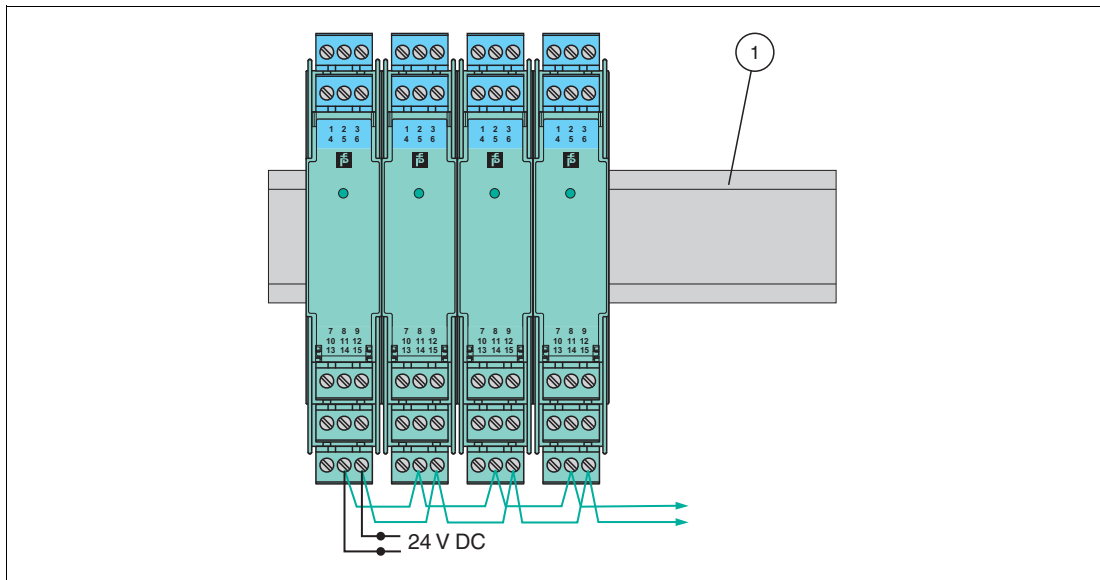

Figure 3.7 Conventional installation

1 DIN mounting rail

3.2.3.2 Power Supply with Power Rail

For devices with a 24 V DC supply voltage, use of the Power Rail reduces wiring and installation costs. The Power Rail almost completely eliminates the risk of wiring faults and facilitates expansion.

Power is supplied to the Power Rail via a power feed module which provides a voltage of 24 V DC (max. 4 A) to a maximum of 80 devices.

The power feed module features a replaceable 5 A fuse at the front. This fuse ensures that the Power Rail and connecting contacts are protected. It prevents damage caused by reverse supply voltage or by installing too many isolators. The isolators on the Power Rail feature integrated device fuses. Any faults in the isolator or in the signal leads do not affect the Power Rail supply system. The 5 A fuse permits a rated current of up to 4 A across the entire temperature range.

The power feed module also has the task of outputting a collective error message or power failure of the isolators via a separate relay output.

Alternatively, supply of the Power Rail can be provided using the power supply KFA6-STR-1.24.*. In this case, no collective error message is possible.

Supply with Power Feed Module



Danger!

Danger to life from electric shock

Absent or insufficient insulation can result in electric shock.

Only connect supplies that provide protection against electric shock to power feed modules (e. g. SELV or PELV).



Caution!

Property damage from use of isolators for Power Rail supply

Using the isolators for Power Rail supply can damage the isolators and make the Power Rail fail.

Do not supply the Power Rail via isolators.



Connecting the Power Supply

Connect the power supply via the Power Rail.

Non-Redundant Supply

The power feed module mounts on the Power Rail for easy and reliable distribution of power to all connected isolators. This method eliminates the wiring loops (daisy chain) necessary on a conventional installation without Power Rail.

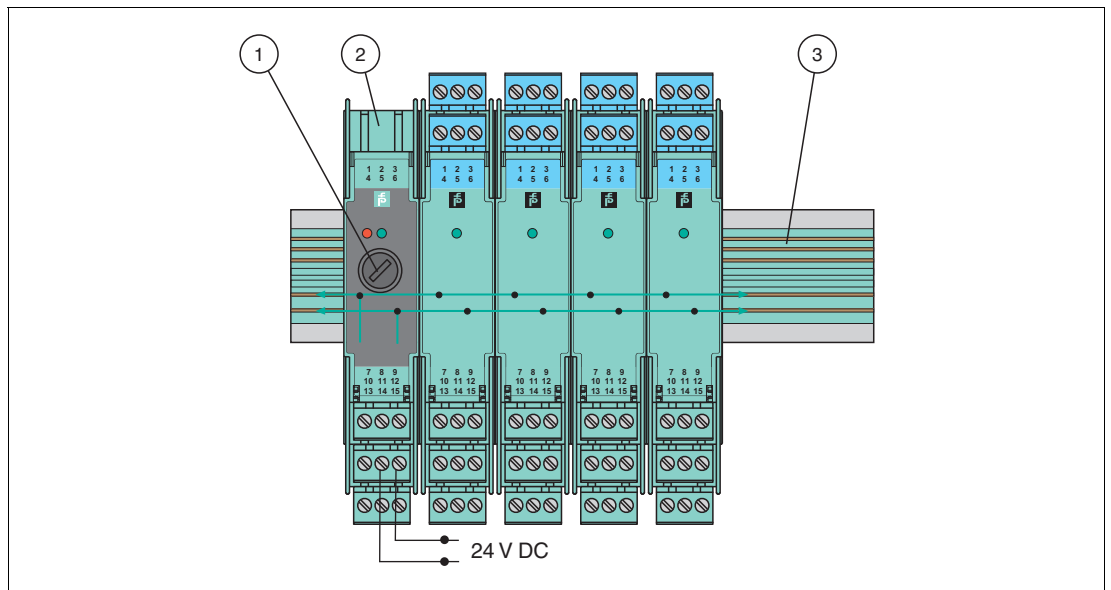

Figure 3.8 Power Rail installation

- 1 Replaceable fuse
- 2 Power feed module
- 3 Power Rail

Redundant Supply

Two power supplies or a redundant power supply with two power feed modules offer a high degree of availability. If a power supply or the fuse in a power feed module fails, the redundant supply continues to energize the isolators through their Power Rail connection.

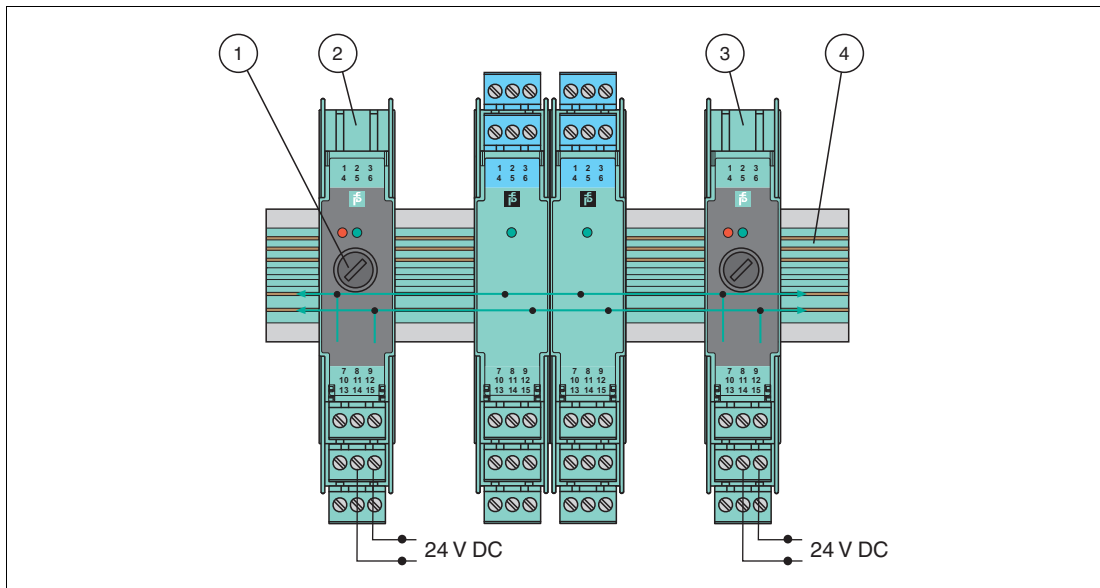

Figure 3.9 Redundant power connections

- 1 Replaceable fuse
- 2 Power feed module 1
- 3 Power feed module 2
- 4 Power Rail

Direct Supply with Power Supply

A complete power solution for a K-System installation is possible by using the following power supplies:

- KFA6-STR-1.24.4 from 115/230 V AC to 24 V DC/4 A or
- KFA6-STR-1.24.500 from 115/230 V AC to 24 V DC/500 mA

The power supplies snap on the Power Rail to easily and efficiently distribute power to the isolated barriers.

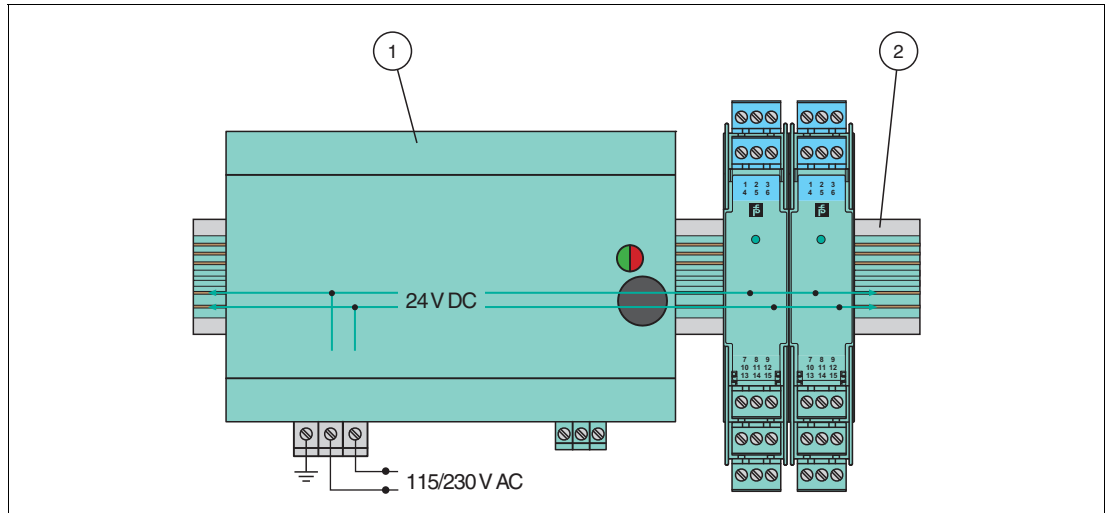

Figure 3.10 Integrated power supply (4 A)

- 1 Power supply
- 2 Power Rail

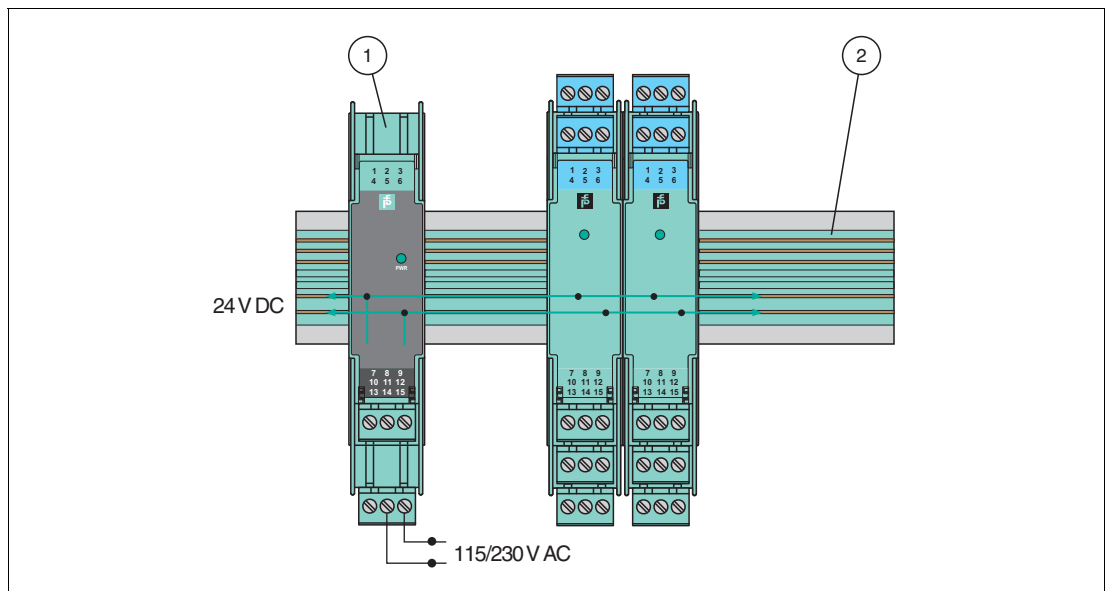

Figure 3.11 Integrated power supply (500 mA)

- 1 Power supply
- 2 Power Rail

3.2.4 Establishing the Communication via Software



Danger!

Explosion hazard from sparking when plugging or pulling the adapter

Plugging or pulling the adapter in a potentially explosive atmosphere can cause sparks that can ignite the surrounding atmosphere.

Only plug or pull the adapter in the absence of a potentially explosive atmosphere.



Caution!

Fault in the plant

Changing the device data changes the device function.

Before entering new device data, make sure the plant is not endangered by changing the device data.



Establishing the Communication via Software

Establish the HART communication via K-ADP-USB adapter and HART multiplexer on the control side, if available.



Note

See manual **HART Multiplexer System KFD*-HM*-16** for further information for communication via software.

4 Configuration



Danger!

Explosion hazard from sparking when using operating elements

Using operating elements in a potentially explosive atmosphere can cause sparks that can ignite the surrounding atmosphere.

Only use operating elements (e. g., switch, slider, button, etc.) in the absence of a potentially explosive atmosphere.



Caution!

Potential device malfunction from change of device function

Changes in the device function can lead to device malfunction. The function of the device is no longer guaranteed.

Before transferring the new device function, make sure that the changed device function does not cause a danger to the device and the plant.



Caution!

Potential device malfunction due to electrostatic discharge

An electrostatic discharge may occur while you are operating the device. This can lead to malfunction of the device. As a result, the function or safety function of the device is no longer guaranteed.

- Ground yourself or provide yourself with an adequate equipotential bonding before operating the device.
 - Only open the front flap while you are operating the device. Otherwise, keep the front flap closed.
-



Configuring the Device

Set the particular operating elements as described in the **Configuration** section of the data sheet.



Note

See corresponding datasheets for further information.

5 Operation



Danger!

Explosion hazard from live wiring of non-intrinsically safe circuits

If you connect or disconnect energized non-intrinsically safe circuits in a potentially explosive atmosphere, sparks can ignite the surrounding atmosphere.

Only connect or disconnect energized non-intrinsically safe circuits in the absence of a potentially explosive atmosphere.



Danger!

Explosion hazard from sparking when using operating elements

Using operating elements in a potentially explosive atmosphere can cause sparks that can ignite the surrounding atmosphere.

Only use operating elements (e. g., switch, slider, button, etc.) in the absence of a potentially explosive atmosphere.



Caution!

Potential device malfunction due to electrostatic discharge

An electrostatic discharge may occur while you are operating the device. This can lead to malfunction of the device. As a result, the function or safety function of the device is no longer guaranteed.

- Ground yourself or provide yourself with an adequate equipotential bonding before operating the device.
- Only open the front flap while you are operating the device. Otherwise, keep the front flap closed.

5.1 Fault Monitoring

Numerous faults can occur between measurement of the process variable and evaluation in the control system. This can lead to undesirable process statuses under certain circumstances. These process statuses may result in plant downtime or quality problems or even present a hazard to persons and the environment. Depending on the device version, the isolators enable monitoring of the following faults:

- Line faults
Here, the connection cables between the isolator, the field device and the control system are monitored for lead breakages or short circuits.
- Device faults
The isolators are designed so that internal faults are detected and reported. In the case of a power failure, the outputs are switched to the de-energized state.

5.2 Fault Output

Depending on the configuration of the devices, these faults are transmitted to the outputs at the control side and in separate fault indication outputs as additional information.

- Red fault indication LEDs on the isolator
- Fault indication output
- Collective error message on Power Rail

Fault Indication Output

Line and device faults are transmitted if the device has a fault indication output (FAULT). The fault indication output is active in a normal state and inactive in a fault state (closed-circuit principle). Is it impossible to reverse the detection direction of the fault indication output.

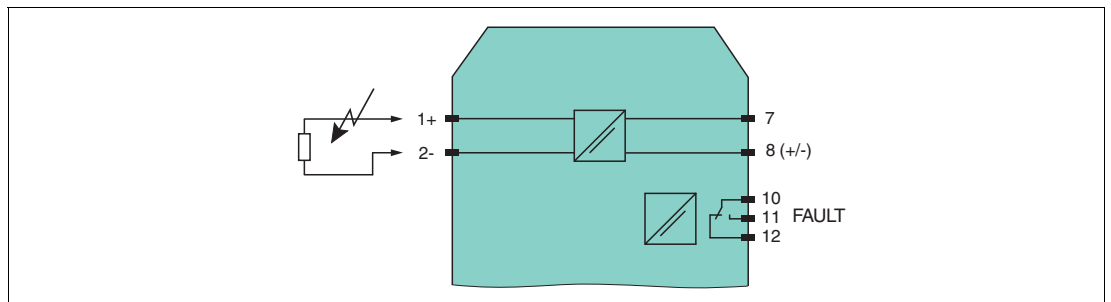

Figure 5.1

Line Fault Transparency (LFT)

Line fault transparency makes electrical conditions on the field side visible on the control side of the isolator. This enables line faults between the isolator and the field device to be detected and transmitted to the control system via the signal line.

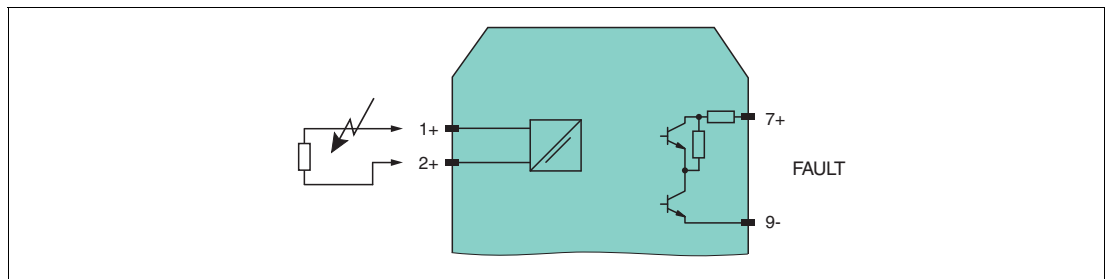

Figure 5.2 Example of line fault transparency with digital input

Collective Error Message on Power Rail

The fault can also be output via the Power Rail as a collective error message (FAULT).

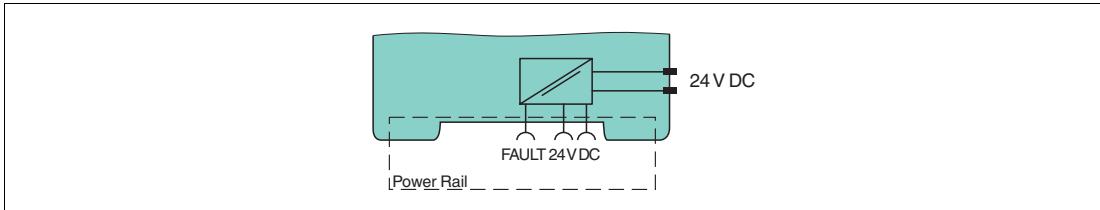

Figure 5.3

The collective error message enables line fault detection of many isolators without requiring additional wiring. In the event of a fault, a fault message signal is transmitted to the Power Rail from an isolator. The power feed module evaluates the signal and transmits the fault message signal to the controller by means of a potential-free contact.

The potential-free contact simultaneously reports the device power failure or the failure of one device minimum.

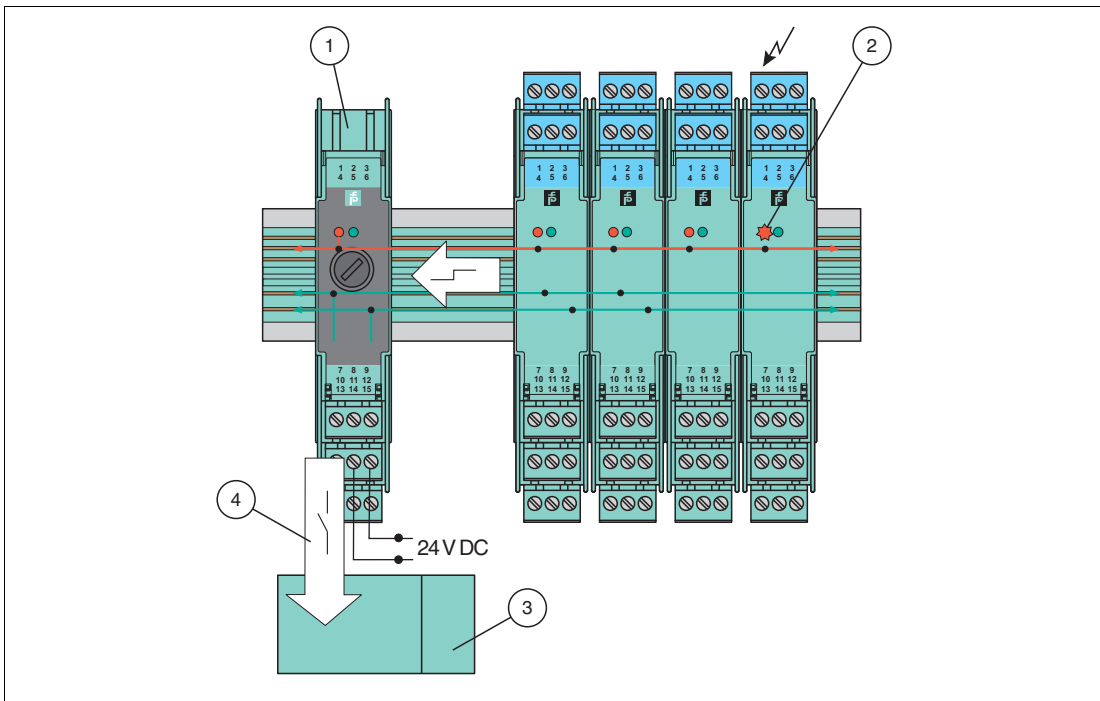

Figure 5.4 Collective error message via power feed module

- 1 Power feed module
- 2 Fault indication on one of the devices (red LED flashes)
- 3 Process control system
- 4 Fault indication output

5.3 Current and Voltage Standard Signals

The following signals have established themselves as the standard:

- the 0/4 mA to 20 mA current signal
- the 0/2 V to 10 V voltage signal
- the 0/1 V to 5 V voltage signal

Analog sensor signals and digital frequency signals are converted into one of the two standard signals for processing in a wide variety of measurement, regulatory and control tasks. This offers the measurement and control technician an easy-to-measure standard signal common to all manufacturers. Sensor signals are converted into standard signals via signal converters.

For more diagnostic options, the NAMUR organization published NAMUR recommendation NE43, dividing the value range of the signal (e. g. current signal) into several areas. Valid, defined measurement value information is transferred within the range from 3.8 mA to 20.5 mA. Failure information is available when the signal current is < 3.6 mA or > 21 mA i. e. outside of the range for measured value information. The same applies to the voltage signal.

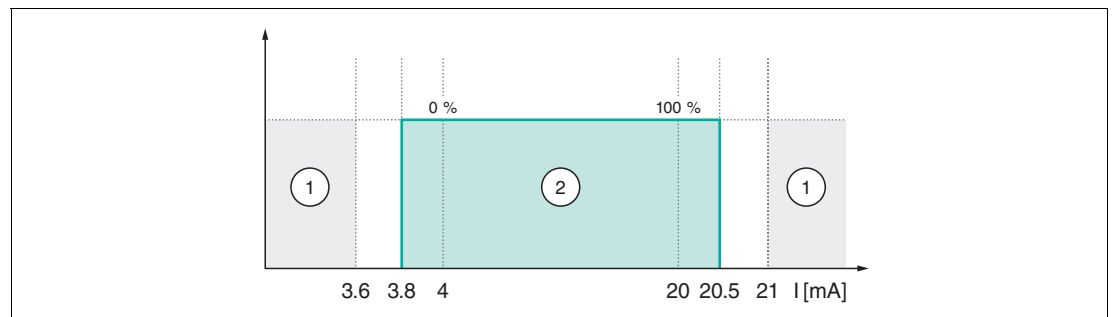

Figure 5.5 Signal ranges according to NAMUR NE43 (e. g. current signal)

- 1 Failure information
- 2 Measuring information

6 Dismounting, Maintenance, and Repair



Danger!

Explosion hazard from live wiring of non-intrinsically safe circuits

If you connect or disconnect energized non-intrinsically safe circuits in a potentially explosive atmosphere, sparks can ignite the surrounding atmosphere.

Only connect or disconnect energized non-intrinsically safe circuits in the absence of a potentially explosive atmosphere.



Danger!

Danger to life from using damaged or repaired devices.

Using a defective or repaired device can compromise its function and its electrical safety.

- Do not use a damaged or polluted device.
 - The device must not be repaired, changed or manipulated.
 - If there is a defect, always replace the device with an original device from Pepperl+Fuchs.
-



Danger!

Danger to life from electric shock

Working on live parts at voltages higher than 50 V AC or 120 V DC can result in electric shock.

1. De-energize the device.
 2. Secure the circuit against reconnection.
 3. Verify that the device is de-energized at all poles.
 4. Provide protection from adjacent live parts, if present.
-



Disconnecting Circuits

1. Disconnect the power supply.
2. Disconnect the field circuit.
3. Disconnect the control circuit.
4. Disconnect the HART communication, if available.

6.1 Dismounting the Isolated Barrier



Dismounting the Isolated Barrier

Use for dismounting of the device a slotted screwdriver

1. Insert the screwdriver (4) into the groove of the red mounting slider (3).
2. Turn the screwdriver (4) in the groove until the red mounting slider (3) springs back.
3. Repeat these steps on the other side of the device.
4. Remove the isolator (2) from the DIN mounting rail (1).

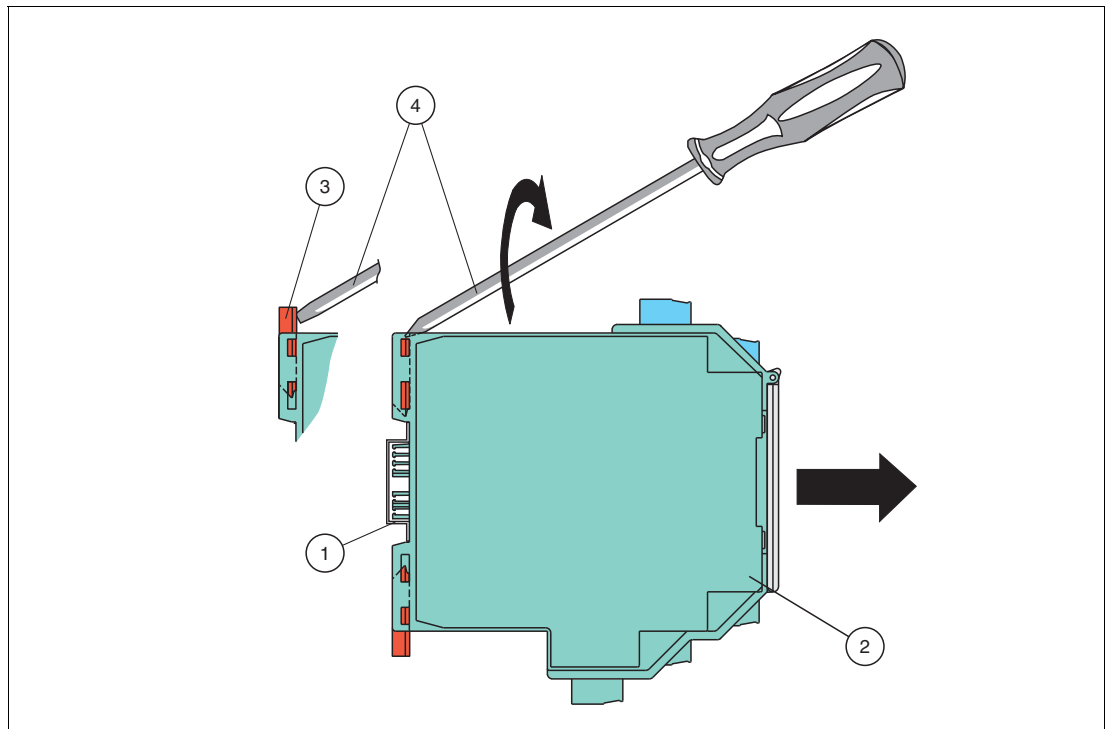

Figure 6.1 Dismounting of the isolated barrier from the DIN mounting rail

- 1 35 mm DIN mounting rail
- 2 Isolated barrier
- 3 Mounting slider
- 4 Slotted screwdriver

7 Technical Specifications

7.1 Technical Data

Electrical Data

Non-Hazardous Area Signals or Control Circuit Signals

- 0/4 mA to 20 mA signal level according to NE 43
- 0/2 V to 10 V signal level according to NE 43
- 0/1 V to 5 V signal level according to NE 43
- Current output HART compatible
- Current input HART compatible
- Digital output: active or passive electronic output 100 mA/30 V, short-circuit protected
- Relay output 2 A, minimum load 1 mA/24 V
- Logic level 24 V according to IEC 60946
- Functional isolation or safe isolation according to IEC 61140 and NAMUR NE 23

Hazardous Area Signals or Signals in the Field Circuit

- Transmitter power supply up to 17 V DC
- Current output HART compatible
- Pt100, 2-, 3-, (4)-wire technology
- Resistor 0 Ω to 400 Ω with freely definable characteristic
- Potentiometer
- Thermocouples of all types, internal cold junction, external reference
- Current output HART compatible
- Digital input according to NAMUR EN 60947-5-6
- Digital output for standard Ex-i valves, short-circuit protected

Characteristic Safety Values

- MTBF: Mean Time Between Failures

Conformity

General

- Isolators with and without explosion protection, mostly with Ex ia IIC/Class I Div. 1, international approvals
- EMV according to
 - EN 61326-1
 - EN 61326-3-2, only for devices with SIL rating, where the data sheet mentions this standard.
If you operate the device with a DC supply voltage, you must ensure that the bridging of the 20 ms voltage interruption is realized by the power supply.
 - NAMUR NE 21
If you operate the device with a DC supply voltage, you must ensure that the bridging of the 20 ms voltage interruption is realized by the power supply.
- RoHS, refer to declaration of conformity of the respective device

- LEDs according to NAMUR NE 44
- Software according to NAMUR NE 53
- Switch-on pulse suppression
- K*D0 devices:
 - Supply voltage 24 V DC, loop powered
- K*D2 devices:
 - Supply voltage 20 V DC to 30 V DC via Power Rail or supply terminals
 - Collective error message via Power Rail
- K*A devices:
 - Supply voltage 115 V/230 V AC, details see datasheet
- K*U devices:
 - Supply voltage 24 V DC or 115/230 V AC, details see datasheet
- Safety devices according to VDE 0660, part 209, AK according to DIN 19250

Digital Inputs and Outputs according to NAMUR

- IEC/EN 60947-5-6: Low voltage switch gear and control gear – part 5 and 6: Control devices and switching elements – DC interface for proximity sensors and switch amplifiers (NAMUR), 1999

Ambient Conditions

Ambient Temperature

- -20 °C to 60 °C (-4 °F to 140 °F), other temperature ranges see datasheets
- extended ambient temperature range up to 70 °C (158 °F), necessary mounting conditions see chapter 3.1

Storage Temperature

- -40 °C to 90 °C (-40 °F to 194 °F), exceptions see datasheets

Reference Conditions for Adjustment

- 20 °C (68 °F)

Relative Humidity

- max. 95 % without moisture condensation

Corrosive gas durability

- according to ISA-S71.04, group A, severity level G3 (harsh)

Altitude

- max. 2000 m

Vibration Resistance

- according to EN 60068-2-6, 10 Hz to 150 Hz, 1 g, high crossover frequency

Shock Resistance

- according to EN 60068-2-27, 15 g, 11 ms, half-sine

Mechanical Specifications

Mounting

- Snap-on 35 mm DIN mounting rail according to EN 60715. Can be mounted horizontally or vertically, side by side.
- Panel mount: The lugs on the base of the isolator must be extended and used for mounting purposes with 3 mm screws.
- K-MS mounting base for screw attachment

Housing Material

- Polycarbonate (PC)

Dimensions

- Dimension drawings please refer to chapter **Dimensions**.

Protection Degree

- IP20 according to EN 60529

Connection

- KH* devices: self-opening terminals for max. core diameter of 1 x 2.5 mm² (14 AWG)
- KF* and KC* devices: removable connector with integrated self opening terminals for leads of up to a max. of 1 x 2.5 mm² (14 AWG)
- Observe the tightening torque of the terminal screws. The tightening torque is 0.5 Nm to 0.6 Nm.

Fire Protection Class

- Housing: V2 according to UL 94 standard. Unless stated otherwise all details relate to the reference conditions.

Labeling

Place for labeling on the front side:

- KC devices (12.5 mm): label 22 mm x 9 mm
- KF devices (20 mm and 40 mm): label 22 mm x 16.5 mm
- All KC and KF devices: adhesive label 22 mm x 11, can only be used on devices with a transparent front flap
- KF devices: label 18 mm x 8 mm, can only be used on devices without a transparent front flap

Note

See corresponding datasheets for further information.



7.2 Model Number Description

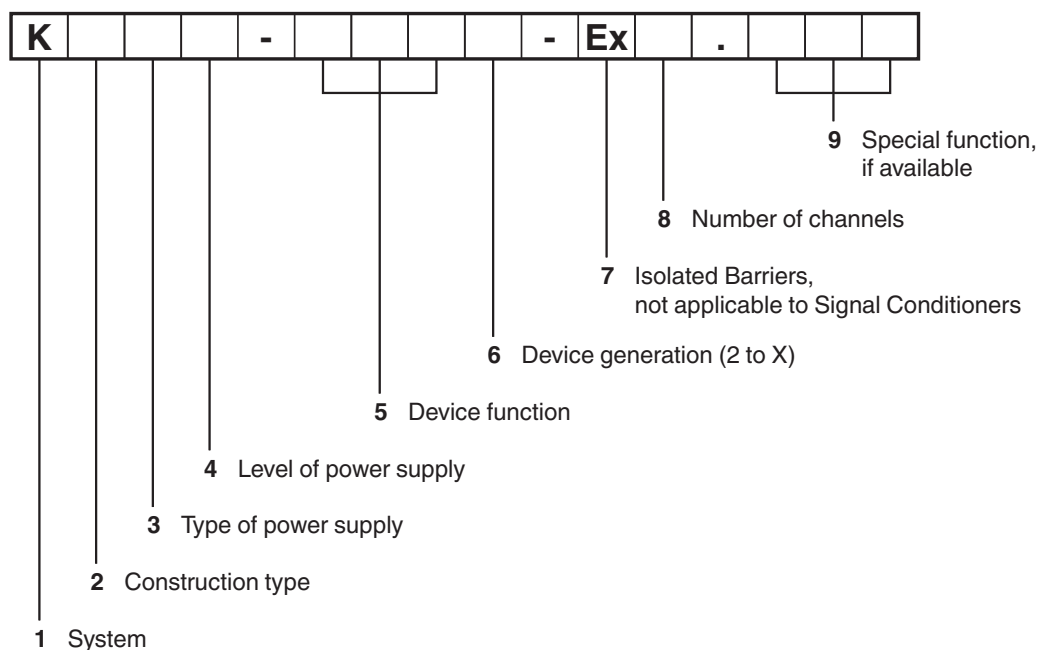

Position 1	K	K-System
Position 2	C	Version with removable terminal blocks, 12.5 mm width
	F	Version with removable terminal blocks, 20 mm or 40 mm width
	H	Version without removable terminal blocks, 20 mm or 40 mm width
Position 3	D	DC power supply
	A	AC power supply
	U	AC/DC power supply
Position 4	0	without power supply
	2	24 V
	4	100 V
	5	115 V
	6	230 V
	8	24 V DC or 115/230 V AC
Position 5	CC	Converter for current/voltage
	CD	Active current driver
	CR	Transmitter power supply, current output
	CRG	Transmitter power supply with trip value
	CS	Passive current driver
	DU	Switch amplifier, time relay
	DWB	Overspeed/underspeed monitor, logic control unit
	EB	Power feed module
	ELD	Ground fault detection
	ER	Conductivity switch amplifier
	FF	RS 232 repeater
	GS	Trip amplifier for current/voltage
	GU	Universal trip amplifier

DOCT-0187Z 2025-02

Position 5	GUT	Temperature converter with trip value
	HLC	HART Loop Converter
	HMM	HART Multiplexer Master
	HMS	HART Multiplexer Slave
	LGH	Place holder isolator
	PT	Potentiometer converter
	RC	Converter for resistors
	RCI	Solenoid driver
	RO	Relay module
	RR	Thermometer resistance repeater
	RSH	Relay module in fail-safe technology
	SCD	SMART current driver
	SCS	SMART current driver/repeater
	SD	Solenoid driver, loop powered
	SH	Switch amplifier in fail-safe technology
	SL	Solenoid driver, bus powered
	SLD	Solenoid driver, bus and loop powered
	SON	Switch amplifier with NAMUR output
	SOT	Switch amplifier with passive, potential free transistor output
	SR	Switch amplifier with relay output
	SRA	Switch amplifier with relay output, 2:1 operation mode
	SRT	Switch amplifier with active transistor and relay output
	ST	Switch amplifier with active transistor output
	STC	SMART transmitter power supply with current output
	STR	Power supply
	STV	SMART transmitter power supply with voltage output
	TR	RTD converter
	TT	Converter for thermocouple/mV signal
	UFC	Universal frequency converter
	UFT	Frequency converter with direction and synchronization monitoring
	USC	Universal signal converter with trip value
	UT	Universal temperature converter
	VC	Converter for current/voltage
	VCR	Transmitter power supply, repeater for current/voltage
	VD	Solenoid driver
	VM	Solenoid driver
VR	Voltage repeater	
WAC	Strain gauge converter	

7.3 Dimensions

7.3.1 Housing Types for K-System Isolated Barriers

Housing Type A2

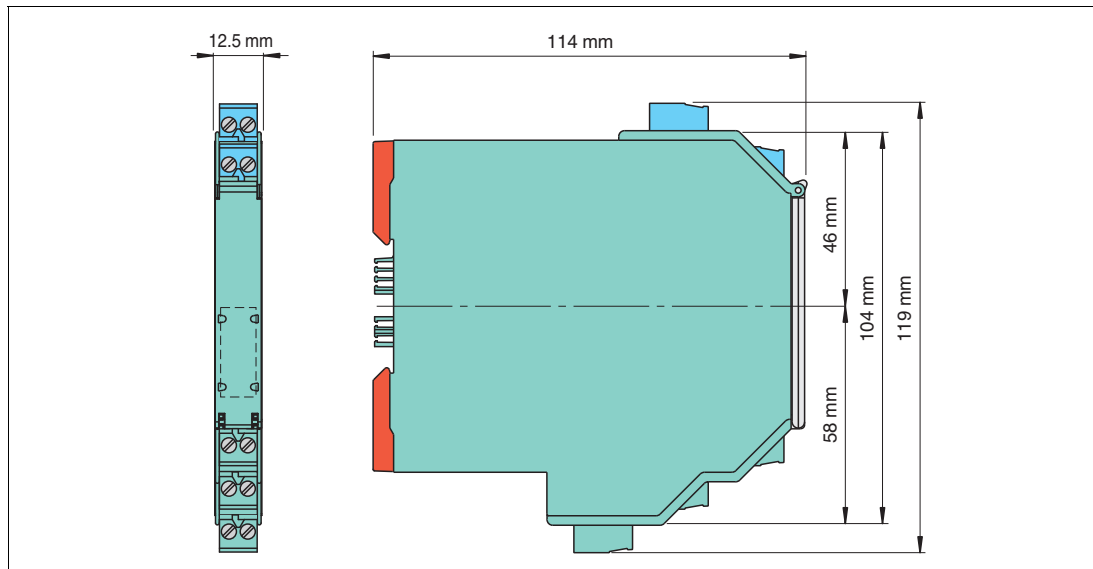

Figure 7.1 Dimensions (W x H x D)

- Device with screw terminals: 12.5 x 119 x 114 mm (0.71 x 4.7 x 4.5 inch)
- Device with screw terminals and test sockets: 12.5 x 124 x 114 mm (0.71 x 4.9 x 4.5 inch)
- Device with spring terminals: 12.5 x 131 x 114 mm (0.71 x 5.2 x 4.5 inch)
- Number of terminal blocks max. 5

Housing Type B1

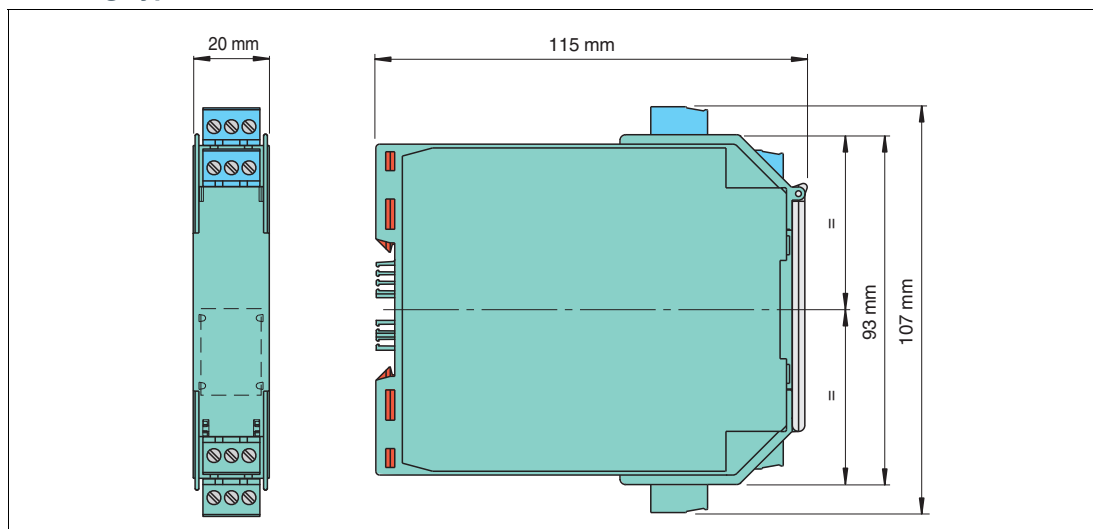

Figure 7.2 Dimensions (W x H x D)

- Device with screw terminals: 20 x 107 x 115 mm (0.8 x 4.2 x 4.5 inch)
- Device with screw terminals and test sockets: 20 x 115 x 115 mm (0.8 x 4.5 x 4.5 inch)
- Device with spring terminals: 20 x 122 x 115 mm (0.8 x 4.8 x 4.5 inch)
- Number of terminal blocks maximum 4

Housing Type B2

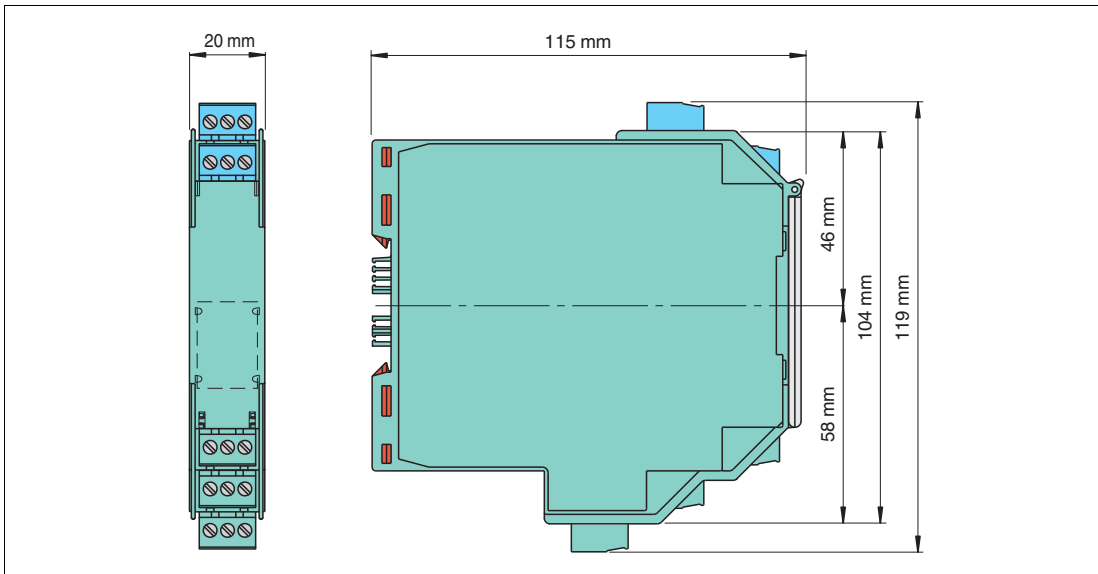

Figure 7.3 Dimensions (W x H x D)

- Device with screw terminals: 20 x 119 x 115 mm (0.8 x 4.7 x 4.5 inch)
- Device with screw terminals and test sockets: 20 x 124 x 115 mm (0.8 x 4.9 x 4.5 inch)
- Device with spring terminals: 20 x 131 x 115 mm (0.8 x 5.2 x 4.5 inch)
- Number of terminal blocks maximum 5

Housing Type C1

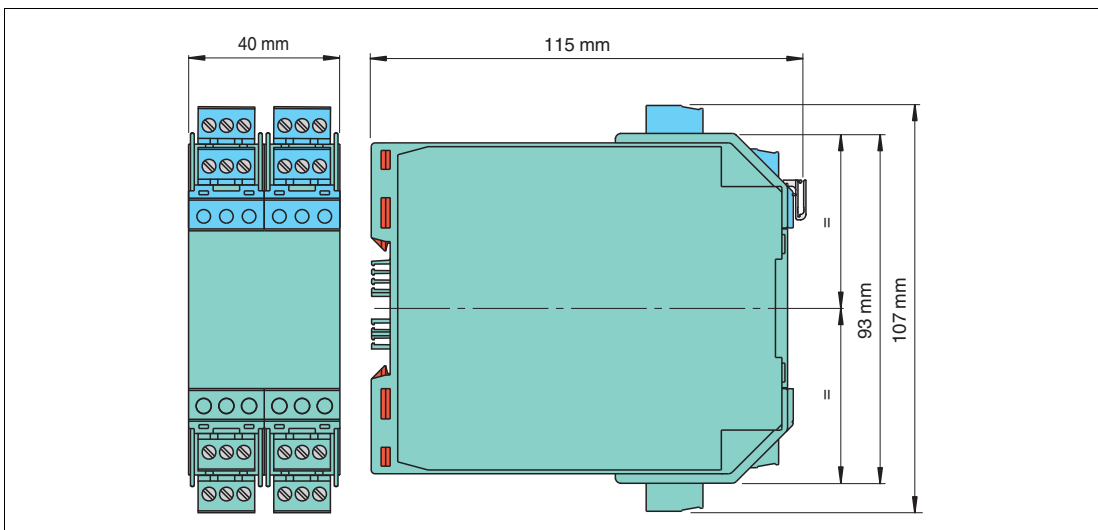

Figure 7.4 Dimensions (W x H x D)

- Device with screw terminals: 40 x 107 x 115 mm (1.6 x 4.2 x 4.5 inch)
- Device with screw terminals and test sockets: 40 x 115 x 115 mm (1.6 x 4.5 x 4.5 inch)
- Device with spring terminals: 40 x 122 x 115 mm (1.6 x 4.8 x 4.5 inch)
- Number of terminal blocks max. 8

Housing Type C2

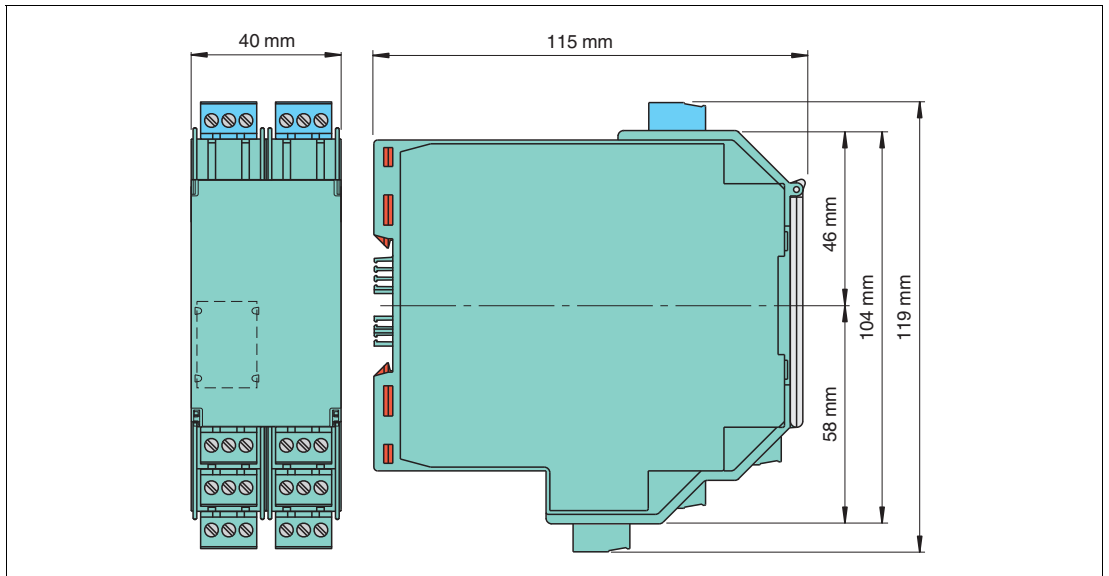

Figure 7.5 Dimensions (W x H x D)

- Device with screw terminals: 40 x 119 x 115 mm (1.6 x 4.7 x 4.5 inch)
- Device with screw terminals and test sockets: 40 x 124 x 115 mm (1.6 x 4.9 x 4.5 inch)
- Device with spring terminals: 40 x 131 x 115 mm (1.6 x 5.2 x 4.5 inch)
- Number of terminal blocks max. 10

Housing Type D2

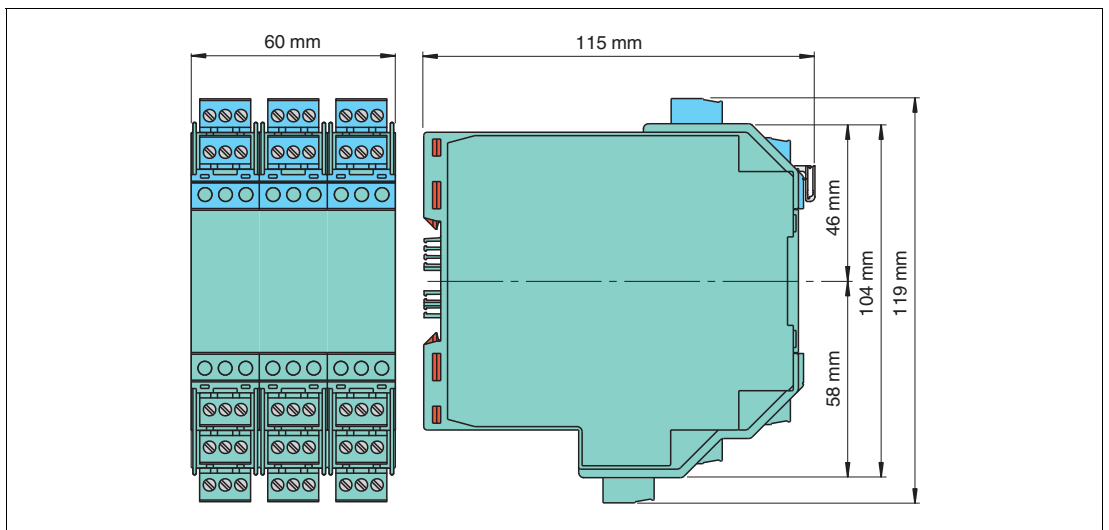

Figure 7.6 Dimensions (W x H x D)

- Device with screw terminals: 60 x 119 x 115 mm (2.4 x 4.7 x 4.5 inch)
- Device with screw terminals and test sockets: 60 x 124 x 115 mm (2.4 x 4.9 x 4.5 inch)
- Device with spring terminals: 60 x 131 x 115 mm (2.4 x 5.2 x 4.5 inch)
- Number of terminal blocks max. 15

Housing Type E

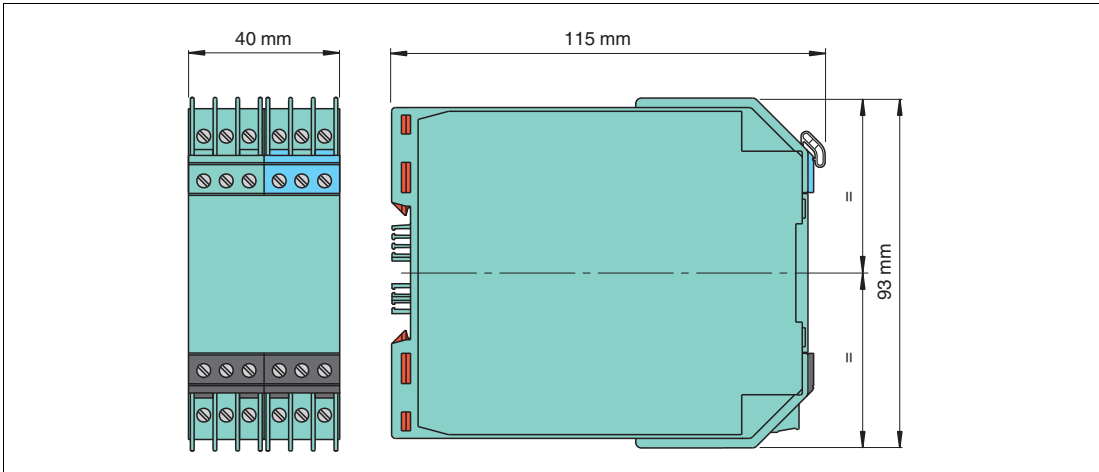

Figure 7.7 Dimensions (W x H x D): 40 x 93 x 115 mm (1.6 x 3.7 x 4.5 inch)

Housing Power Supply 4 A

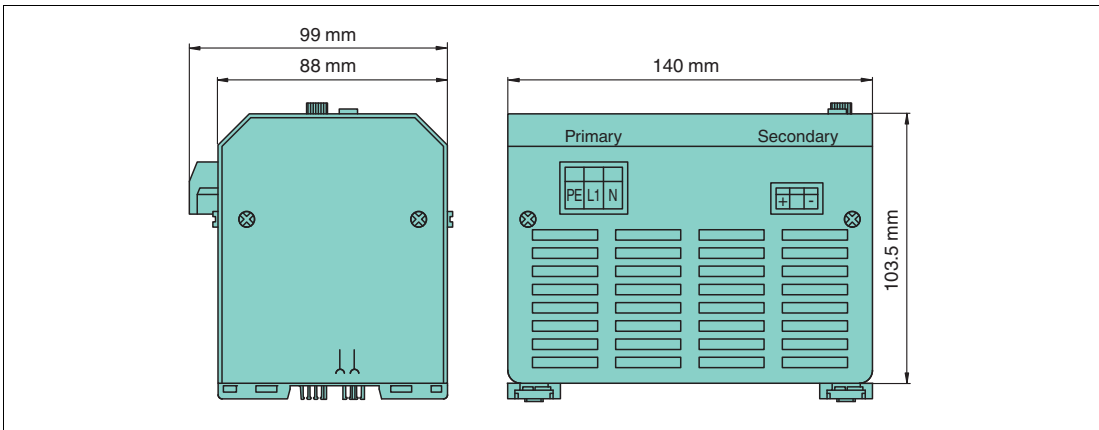

Figure 7.8 Dimensions (W x H x D): 140 x 99 x 103,5 mm (5.5 x 3.9 x 4.1 inch)

Your automation, our passion.

Explosion Protection

- Intrinsic Safety Barriers
- Signal Conditioners
- FieldConnex® Fieldbus
- Remote I/O Systems
- Electrical Ex Equipment
- Purge and Pressurization
- Industrial HMI
- Mobile Computing and Communications
- HART Interface Solutions
- Surge Protection
- Wireless Solutions
- Level Measurement

Industrial Sensors

- Proximity Sensors
- Photoelectric Sensors
- Industrial Vision
- Ultrasonic Sensors
- Rotary Encoders
- Positioning Systems
- Inclination and Acceleration Sensors
- Fieldbus Modules
- AS-Interface
- Identification Systems
- Displays and Signal Processing
- Connectivity

Pepperl+Fuchs Quality

Download our latest policy here:

www.pepperl-fuchs.com/quality

