



INSTRUCTION MANUAL
CONTROL UNIT SC4-2

SafeBox



With regard to the supply of products, the current issue of the following document is applicable: The General Terms of Delivery for Products and Services of the Electrical Industry, published by the Central Association of the Electrical Industry (Zentralverband Elektrotechnik und Elektroindustrie (ZVEI) e.V.) in its most recent version as well as the supplementary clause: "Expanded reservation of proprietorship"

1	SC4 control system	7
1.1	Intended use	7
1.2	Product description and features	7
2	Declaration of conformity	8
3	The SC4-2 control unit.	9
3.1	Product description	9
3.2	Working principle	9
3.3	Layout	10
3.4	SC4-2 connections	12
3.5	SC4-2 displays	16
4	Operating modes	17
4.1	Start/restart interlock (Restart)	19
4.2	Relay monitor	19
5	Setup and assembly of the light barriers	21
6	Installation	24
6.1	SLA light barriers	24
6.2	Message outputs	25
6.3	Safety outputs	26

7	Commissioning	26
7.1	Adjust protective beams	26
7.2	Layout with adjustable mirror	27
7.3	Verifying functionality	27
7.3.1	Test of detection capability of the installed electrosensitive protection device	27
7.3.2	Test of start/restart interlock and startup enable (restart/start)	28
7.3.3	Testing the test/reset connection	28
7.3.4	Test of relay monitor	28
7.3.5	Principle of operation of the OSSD outputs	29
8	Periodic checkup	29
9	Troubleshooting	30
10	Technical data	32
10.1	Parameters	32
10.2	Dimensions	34
10.3	Accessories	34
10.4	Ordering information	34
11	Sample circuits for SC4-2	35
12	Glossary	37
13	Standards	38
13.1	Construction and equipping of protective equipment	38
13.2	Use and installation of protective equipment	38
14	Notes	40

Please note!

These operating instructions contain information on the intended use of the product and serve to protect users from danger. They must be read and observed by all persons who implement, use, care for, maintain and monitor this product. This product can only fulfill the tasks for which it is intended if it is used, cared for, maintained and monitored in accordance with the instructions of Pepperl+Fuchs.

The warranty undertaken by Pepperl+Fuchs for this product becomes null and void if it is not used, cared for, maintained and monitored in accordance with the instructions of Pepperl+Fuchs.

Before selecting and using the product, an evaluation must be performed to determine whether it is suitable for the purpose in question. The selection and range of application are not subject to the influence of Pepperl+Fuchs. Our liability is therefore limited to consistent quality of the product.

The product must be regularly monitored and maintained by professionals. The results of inspections and maintenance tasks must be kept in logs. Only original Pepperl+Fuchs parts must be used for repair jobs.

Changes to the devices or components and the use of defective or incomplete devices or components are not permitted. Repairs to devices or components may only be performed by Pepperl+Fuchs or authorized work shops. These work shops are responsible for acquiring the latest technical information about Pepperl+Fuchs devices and components.

Repair tasks made on the product that are not performed by Pepperl+Fuchs are not subject to influence on the part of Pepperl+Fuchs.

Our liability is thus limited to repair tasks that are performed by Pepperl+Fuchs.

The preceding information does not change information regarding warranty and liability in the terms and conditions of sale and delivery of Pepperl+Fuchs.

This device contains sub-assemblies that are electrostatically sensitive. Only qualified specialists may open the device to perform maintenance and repair tasks. Touching the components without protection involves the risk of dangerous electrostatic discharge, and must be avoided. Destruction of basic components caused by an electrostatic discharge voids the warranty!

Symbols used

This manual uses symbols to present important information on operating the SC4-2 and working safely with it. The meaning of these symbols is as follows:



Recommendation for the user

Observing these notes will make it easier to place the system in operation and to work with the SC4-2.



Refers to a hazard or an immediate danger.

Failure to observe such instructions may result in damage to property, serious injury or death.

Subject to technical modifications.

14 SC4 control system

14.1 Intended use

In combination with light barriers of type SLA, the SC4 control system represents a photoelectric protective device. Protective beams are formed between transmitters and receivers.



This system must only be used in accordance with intended purpose as electrosensitive protection device for securing access to hazardous points and areas. Any use not in accordance with these conditions does not comply with usage in accordance with the intended purpose.

Applicable safety rules, standards and requirements must be observed during usage, and the specific requirements in the application in question must be taken into consideration.

14.2 Product description and features

The SC4 analysis system is an electrosensitive protection device of Type 4 (EN IEC 61496-1) or Category 4 (EN 954-1).

System features:

- Selectable start/restart interlock (restart interlock RI)
- Selectable relay monitor (RM)
- Red transmitter light for easy adjustment of light barriers
- Function reserve display on each receiver
- 7-segment display to make it easy to pinpoint errors

15 Declaration of conformity

This product was developed and manufactured under observance of the applicable European standards and guidelines.



Note!

A Declaration of Conformity can be requested from the manufacturer.

The product manufacturer, Pepperl+Fuchs GmbH, D-68307 Mannheim, has a certified quality assurance system that conforms to ISO 9001.



Note!

See technical data for applied harmonized standards.

16 The SC4-2 control unit

16.1 Product description

With its light barriers of Type SLA, the SC4-2 control unit represents a one or two-beam photoelectric protective device. It consists of 2 modules,

- the OSSD Module with a 2-channel relay output (OSSD) and
- the light barrier module.

16.2 Working principle

Two protective beams are generated by the two light barriers that can be connected to the light barrier module. Depending on the type of light barriers, the detection range of the protective beams may be 10 m, 30 m or 65 m. Interruptions in a light beam are determined by the light barrier module. The OSSDs and the OSSD message output in the OSSD Module are turned off. Downstream equipment in the machine control system responds by turning off the dangerous motion.

A safety-related microprocessor control system permanently monitors the functionality of the light barriers and the internal safety system. This ensures that errors are detected within the defined response time of the system and that they result in the OSSDs being turned off.

If an error is detected by the test, the OSSDs remain in the Off state. In addition, a flashing signal is generated on the "Readiness for startup" output (flashes at a rate of once per second) and the 7-segment display on the SC4-2 displays the error that was detected.

The startup / restart lock and monitoring of EDM feedback (relay monitor) can be turned on or off as required with switches on the SC4-2.

If the start/restart interlock is activated on the control unit, the "Restart" (Start) output is turned on if the light beams are free.

After the operating mode is changed or after an error is eliminated, a reset must be performed by briefly turning off the operating voltage.

16.3 Layout

An electro-sensitive protection device of the type described here consists of:

- An SC4-2 control unit (light barrier module, OSSD module)
- One or two light barriers of Type SLAxx
- (Optionally) a power pack (for power supply with alternating current)

The SC4-2 is housed in a case suitable for mounting on a top hat section rail. The installation width is 45 mm.

The following operating modes can be set as desired with DIP switches that are accessible after the case is opened

- Start/restart interlock (restart interlock RI)
- Relay monitor (RM)

(located in the light barrier module).

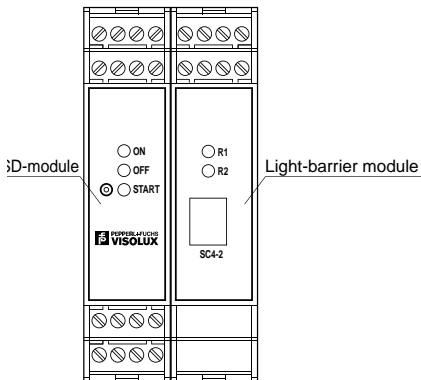

Figure 16.1: SC4-2 control unit

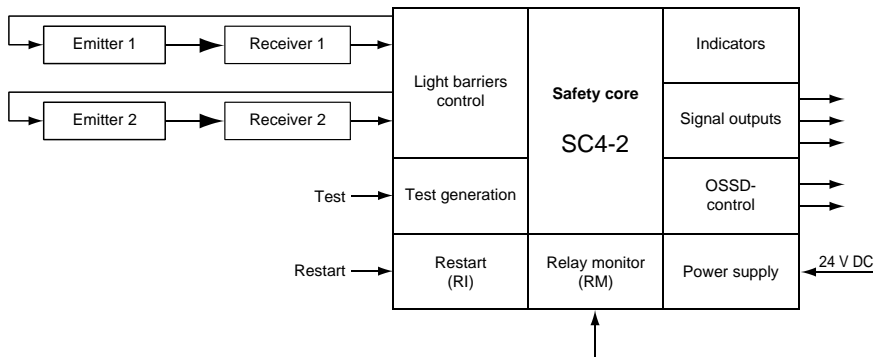

Figure 16.2: Principle of operation of the SC4-2

16.4 SC4-2 connections

Terminals are used to connect the light barriers, inputs and outputs and the voltage supply. Four terminals are combined to form each terminal block. These terminal blocks can be disconnected, thus making it easy to switch devices.

A light barrier channel that is not in use is jumpered (see section 19.1)

Terminal	Assignment	Function
1	pnp output readiness for startup message	Option for connecting external indicator lamps to indicate restart (start) or error message (see section 17.1)
2	PNP output OSSD reporting OFF	Option for connecting external indicator lamps to indicate the OSSD state Off
3	PNP output OSSD reporting ON	Option for connecting external indicator lamps to indicate the OSSD state On
4	0 V internal	Reference point for pnp outputs
5	Startup enable for input (RI)	Normally open contact for start/restart interlock. It should be wired in if no function is activated (see section 17.1)
6	24 V internal	
7	Relay monitor input (RM)	Relay monitor input. It should be wired in if no function is activated (see section 17.2)
8	24 V internal	
9	24 V DC	Supply voltage connection, protected from reverse polarity
10	0 V	
11	24 V internal	Normally open contact for testing or error enable
12	Test input	

Table 16.1: Connections of the SC4-2 OSSD module

Terminal	Assignment	Function
13	OSSD1.1	OSSD relay output 1 NO (normally open)
14	OSSD1.2	
15	OSSD2.1	OSSD relay output 2 NO
16	OSSD2.2	

Table 16.1: Connections of the SC4-2 OSSD module

Terminal	Assignment	Function
25	LS2-T	Transmitter 2 connection
26	LS2-T 0V	
27	LS2-R 0V	Receiver 2 connection
28	LS2-R	
29	LS1-T	Transmitter 1 connection
30	LS1-T 0V	
31	LS1-R 0V	Receiver 1 connection
32	LS1-R	

Table 16.2: SC4-2 connections for light barrier module

SC4-2 light barrier module		Receiver		Transmitter	
		Conductor	Pin	Conductor	Pin
LS2-T transmitter	25			BK (black)	4
	26			BU (blue)	3
LS2-R receiver	27	BU (blue)	3		
	28	BN (brown)	1		
LS1-T transmitter	29			BK (black)	4
	30			BU (blue)	3
LS1-R receiver	31	BU (blue)	3		
	32	BN (brown)	1		

Table 16.3: Connection assignment of light barriers

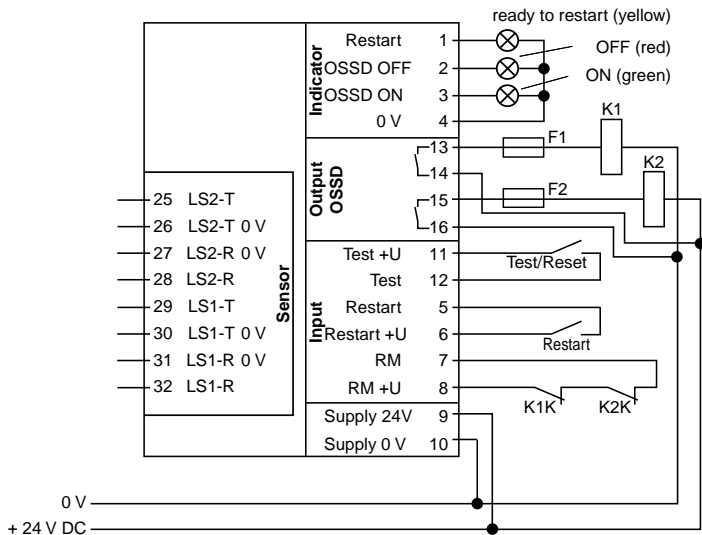

Figure 16.3: SC4-2 connections

16.5 SC4-2 displays

Displays for the switching state of the OSSD and status displays for indicating the operating status are located on the front plate of the two modules of the SC4-2.

Display	LED	Meaning
OFF	Red	OSSD output turned off
ON	Green	OSSD output turned on
Start	Yellow	Continuous light: Protective field free, OSSD off, readiness for startup,
		Flashing activate restart button System error (see Status E1, E2)
R1	Yellow	Status of light barrier 1
		Off: Interrupted
		On: Light beam free
R2	Yellow	Status of light barrier 2
		Off: Interrupted
		On: Light beam free
		Flashing: Light beam free, level below function reserve

Table 16.4: Status displays

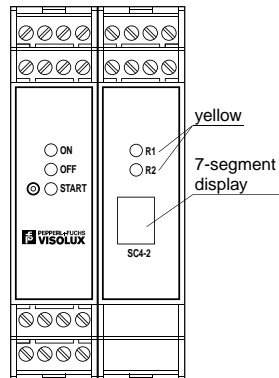

If an error is present, the yellow LED flashes, indicating readiness for startup. The 7-segment display shows the error that has been detected (Table 16.5).













Display	Meaning	Display	Meaning
	Protective beams free, OSSD ON (running light)		Error on one of the transmitters
	One or both protective beams interrupted		Extraneous light detected
	Protective beams free, OSSD off, readiness for startup		Sensor error in Channel 1
	System start		Sensor error in Channel 2
	DIP switch position incorrect		System errors
	Both light barrier channels jumpered		Error in an external relay

Table 16.5: 7-segment display

17 Operating modes

The operating modes of the SC4 can be adjusted using DIP switches. Two switches must be activated to set an operating mode. The DIP switches are located inside the housing of the light barrier module.

To activate the DIP switches, pull out the right sub-assembly. To do this, press on the upper and lower unlocking mechanism with a screwdriver. The sub-assembly can be pulled out as far as the holding mechanism and the DIP switches are then accessible.

After the operating mode is changed, a reset should be triggered by turning off the operating voltage briefly.

You should note on the manufacturer's rating plate (Figure 17.2) with indelible ink which operating mode was selected. The operating mode that is set should be monitored by an appropriate check (see section 20.3).

When the control unit is delivered, the relay monitor (RM) is turned off and start/restart interlock (RI) is turned on.

	DIP switches			
	1	2	3	4
Start/restart interlock (RI)			X	X
Relay monitor (RM)	X	X		

Table 17.1: Function of the DIP switches

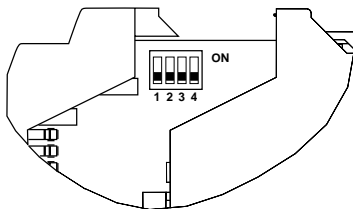
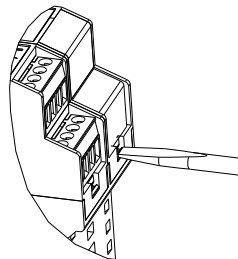

Figure 17.1: Position of the DIP switches



Opening of the housing

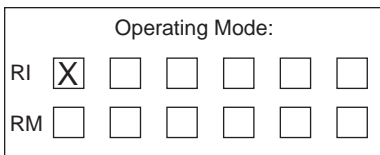

Figure 17.2: Adhesive label for marking the operating mode

17.1 Start/restart interlock (Restart)

If the protective beams are free and the start/restart interlock operating mode is activated, do not turn the OSSDs and the OSSD-ON message on. The "Restart" output is activated and the corresponding yellow display LED lights up. After the "Restart" (Start) button is pressed, the OSSDs and OSSD-ON message turn on and the "Readiness for startup" output is turned off.

17.2 Relay monitor

With the OSSD switch outputs, the SC4 is able to perform safety-related monitoring of time-correlated external switching elements with the aid of feedback contacts. Normally closed contact of force-guided relays should be used as feedback contacts. The feedback contacts of all downstream external switching elements should be wired in series. Series switching should be connected on the first side with the positive voltage supply (Terminal 8) and on the other side with Terminal 7.

The feedback contacts of the external switching elements must ensure a reliable contact at a voltage of 20 V and a current of 6 mA. Resistance to peak voltages of 6 kV must be guaranteed between the feedback contacts and other contacts that are at low voltage in accordance with the low voltage directive.



*The work circuit of the external switching elements must be protected by a fuse with a nominal value of maximum 60 % of the load capacity of the contacts to prevent the contacts from fusing. The external switching elements are monitored with a delay of 180 ms following the switching process. If the new switching state is not assumed by the time the monitoring period expires (180 ms), the SC4 switches into interlock state and the 7-segment display shows an **F**. This error should be acknowledged after the cause is eliminated by a reset on SC4.*

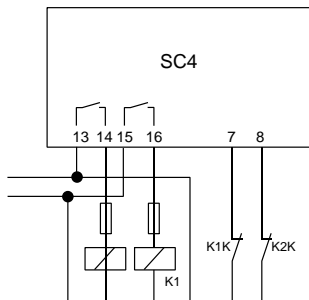

Figure 17.3: Sample connection of relay monitor

18 Setup and assembly of the light barriers

Safety light barriers should be arranged so that the transmitters connected to the various SC4 light barrier modules cannot direct beams at the receivers of other control units.

Safety light barriers must be mounted in such a manner that it is not possible to reach the hazardous area by bypassing the protective beams.

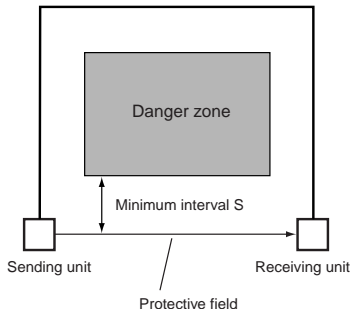

Figure 18.1: Minimum distance between the electro-sensitive protection device and the hazardous area

It must not be possible:

- to crawl under the lowest beam,
- to climb over the highest beam or
- to walk between two beams

To calculate the minimum distance of the photoelectric sensor from the hazardous area, please refer to the applicable requirements and standards.

In accordance with EN ISO 13855, the minimum distance may be calculated by the formula:

$$S = K \cdot T + C$$

Where

S = the minimum safety distance in mm, i.e. the distance from the hazardous area to the protective field

K = the constant in mm/s for the approach speed

T = the total response time in s,

$$T = t_1 + t_2$$

t1: response time of the protective device 30 ms

t2: response time of the machine

C = additional distance in mm. This depends on how far a person can penetrate into the hazardous area before the protective equipment is triggered.

According to EN ISO 13855, the following heights are recommended for individual beams parallel to the floor if the risk evaluation permits it:

Number of beams	Height above the reference level in mm
1	750
2	400, 900

Table 18.1: Distances between protective beams above the floor



Care should be taken that reflecting objects that could result in mirroring of an obstruction are not located within the transmitter or receiver lobe (EN IEC 61496-2).

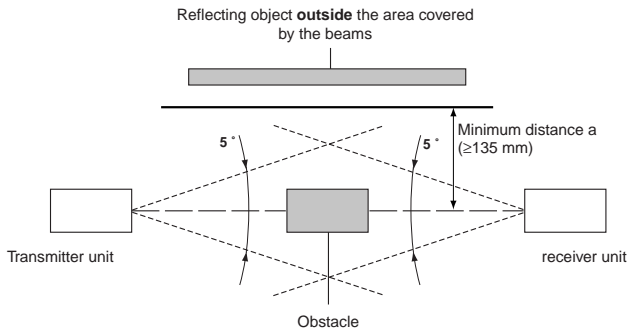

For a section $a > 3$ m, the minimum distance s is calculated at:

$$s = a \times \tan 2,5^\circ$$

Section a	Minimum distance S
3 m	135 mm
5 m	220 mm
10 m	440 mm
15 m	655 mm

Table 18.2: Safety distances deflection

Figure 18.2: Deflection

19 Installation

When the SC4 is integrated into the safety-related control system of the machine, the instructions in EN 61496-1 along with others must be taken into consideration (including electrosensitive protection device control elements downstream in the circuit).



The following points should be taken into consideration during the installation:

- Have applicable standards and requirements been observed?
- Does the technical data of the electrosensitive protection device correspond to the requirements of the application?
- Have the necessary distances been taken into consideration?
- Are all inputs and outputs correctly wired into the circuit?
- Is it impossible to defeat the protective equipment?
- Is the restart button positioned so that the hazardous area is completely visible from it?
- Do you want the button not to be activated from within the hazardous area?

19.1 SLA light barriers

Light barrier transmitters and receivers are connected according to the color of the individual conductors or the pin numbers on the light barrier module.

SC4-2 light barrier module		Receiver		Transmitter	
		Conductor	Pin	Conductor	Pin
LS2-T transmitter	25			BK (black)	4
	26			BU (blue)	3

Table 19.1: Connection assignment of light barriers

LS2-R receiver	27	BU (blue)	3		
	28	BN (brown)	1		
LS1-T transmitter	29			BK (black)	4
	30			BU (blue)	3
LS1-R receiver	31	BU (blue)	3		
	32	BN (brown)	1		

Table 19.1: Connection assignment of light barriers

The length of the connection cable between the control unit and transmitter or receiver must not exceed 50 m. The specifications for the connection cable are given in Section 23.

If only one protective beam will be used, the second light barrier channel should be replaced by an appropriate jumper wire.

Light barrier to be replaced	Jumper wire
1	29 - 32
2	25 - 28

Table 19.2: Light barrier channels that are not used

19.2 Message outputs

Three short-circuit-proof message outputs are available on the OSSD module for external displays to indicate the status of the electrosensitive protection device at a suitable external location as well (Terminals 1 to 3).

19.3 Safety outputs

The OSSD relay outputs must be protected externally with fuses. All pnp outputs are protected against short-circuit and do not require any external fuses.

With an inductive load of the relay output contacts, the latter must be protected against the increased load that is thus generated by RC combination or freewheeling diodes. The circuitry must be wired directly to the load.



When using freewheeling diodes, it should be noted that the pulse decay time of the connected relays or contactors is extended.

20 Commissioning

20.1 Adjust protective beams

The transmitter and receiver should be aligned to each other so that they are at the same height in reference to each other and the lowest beam is at the correct height above the floor.

The alignment of the transmitters can be facilitated with the aid of a reflector. The reflector is arranged in front of the receiver's receiver optics. When the system is turned on, detection will then only operate from the transmitter in the direction of the reflector. The transmitter should be adjusted so that you can see the red transmitter light. The transmitter should be fastened in place. Now rotate the receiver so that the functional display indicates steady light.

If the red transmitter light cannot be properly observed (for example in the case of great detection ranges) a laser alignment aid should be used .

20.2 Layout with adjustable mirror

Adjustable mirrors are used for deflection away from protective beams and fields for securing them on multiple sides with only one transmitter/receiver pair. Each mirror reduces the maximum detection range by a maximum of 15%.

The mirror should be set up so that light beams coming from the transmitter are deflected to the receiver. If the deflection of the protective field is at a right angle, the mirror should be at an angle of 45°.

Once the layout is aligned, you should check to make certain that all components are positioned vertically at the same level. To align the mirror roughly, turn the mirror so that you can see the receiver in the mirror if you look out from the transmitter in the direction of the mirror.

The alignment can be facilitated by using a laser alignment aid.

Make certain that the surfaces of the mirror are clean. Use cleaning materials that will not scratch and lint-free cloths for cleaning.

20.3 Verifying functionality

20.3.1 Test of detection capability of the installed electrosensitive protection device

The following tasks must be performed to test the detection capacity:

- Remove all objects from the beam paths.
- Interrupt all light beams one after the other. As you do so, the OSSD output must switch into the Off state (red display lights up and the 7-segment display indicates **0**).

20.3.2 Test of start/restart interlock and startup enable (restart/start)

- Interrupt one beam and then make all beams free.
- Output relays must remain blocked if there is an existing startup interlock, and the indicator light for readiness for startup must light up or the "Restart" (Start) LED must light up and the 7-segment display indicate an **A**
- Activate the startup contact for 0.05 ... 1 seconds (RESTART)
- The OSSD outputs and OSSD-ON message output must switch on, the indicator light for readiness for startup must go out and the 7-segment display must indicate a circulating bar (running light).

20.3.3 Testing the test/reset connection

- Remove all objects from the beam path.
- If there is a startup lock, activate the startup enable contact (RESTART).
- The OSSD outputs must switch on.
- Initiate the test/reset
- The OSSD outputs must switch off.
- After the test is complete, the output switches on again if the startup interlock is not activated. If the startup lock is activated, the "Restart" (Start) condition must be reached

20.3.4 Test of relay monitor

- Switch to voltage-free state
- Interrupt the connection line between the external contact and the control unit
- Turn on the control unit
- The "Restart" (Start) status display must flash and the 7-segment display must indicate an **F**.
- Connect the interrupted lead again.
- Activate the test (error reset)

20.3.5 Principle of operation of the OSSD outputs

The OSSD outputs are turned on under the following conditions:

- With active startup lock: The protective beams are free and startup is enabled.
- Without startup lock: The protective beams are free.

The OSSD outputs remain turned on under the following condition:

- No protective beam is interrupted.

The OSSD outputs are turned off under the following conditions:

- The protective beams are interrupted.
- An error state is detected.
- The test input is activated.

21 Periodic checkup

A daily test is required if it cannot be ensured that:

- an external test is used for verification
- A protective field interruption occurs at least once per day
- or the device is not turned on at least once each operating day.

The test is performed as follows:

- Make the protective field free and enable startup
- Interrupt the protective field at any beam and observe the display of the OSSD status as you do so. It must switch from green to red.

If the control unit does not receive any fault status, the test is complete.

The periodic verification of the safety function of the system into which the SC4 control system is installed must also monitor the functions of the electrosensitive protection device. Among other things, the proper layout, installation and required response time must be checked. Test records of tests that have been carried out must be created and kept.

22 Troubleshooting

Errors in the system always result in the system making a transition to the secure interlock state. The OSSDs are then turned off. Errors bring the system to a status that generates an error display.

The output for readiness for startup can be used to indicate an error externally. The output switches on and off at a rate of once per second in the event of an error

To acknowledge an error, the operator presses the test input for 0.05...1 s, thus executing a reset. The same effect can be achieved by interrupting the operating voltage briefly. The SC4 goes into a start condition after a system test has been successfully performed or stops in the error state with the corresponding error display (see also Section 16.5).

For high-frequency electro-magnetic fields with a field intensity of 10 V/m or greater, the control unit can switch into the secure state. If this error arises, the test contact (reset) should be activated and the SC4 will eliminate the error state by performing a system reset. If the system is not successful in eliminating the error state, an attempt should be made to return to normal operation by interrupting the operating voltage for at least 1 second and then turning it back on.

Possible measures you can take yourself are described below:

Display	Possible fault remedy
Displays are not lit up on all components of the system	Check the power supply.
External protective field display (OSSD red and green) is not lit	Check the installation
Readiness for startup state cannot be acknowledged (Readiness for startup display lights up)	Test the startup release button and its installation.

Table 22.1: Troubleshooting

Display	Possible fault remedy
LEDs for the protective beam do not light up	The protective beams are not free. Make the protective beam free. Check the status of the displays on the receivers. Check whether all transmitters are lit up. Eliminate any dirt spots. If necessary, readjust the transmitter and receiver. Check the installation.
Error display E System error	Activate the test or turn the voltage supply off and back on again. If the error occurs continuously, there is an internal error present. Send the SC4 control system in for repairs.
Error display 1 DIP switch setting incorrect	Check the DIP switch setting
Error display F Error in an external relay	Check the installation of the relay monitor (are the feedback contacts normally open contacts?). If the system is supposed to work without a relay monitor, turn off the corresponding DIP switches.
Error display 3 both light barrier channels are jumpered	Check the cable between SC4 and the light barriers (transmitter and receiver) One possible error is: - Both channels have been taken out of operation by a jumper wire
Error display 4 Error on one of the transmitters	Check the cable between SC4 and the light barriers (transmitter and receiver) One possible error is: - Short-circuit on a transmitter connection
Error display 7 Extraneous light detected	Check the layout of the light barriers; malfunction caused by external malfunction source (external sensor affecting receiver)
Error display 8 Sensor error Channel 1	Check the cable between SC4 and the light barriers (transmitter and receiver) One possible error is: - The receiver is not connected correctly (interruption or short-circuit)
Error display 9 Sensor error Channel 2	Check the cable between SC4 and the light barriers (transmitter and receiver) One possible error is: - Receiver s is not connected correctly (interruption or short-circuit)

Table 22.1: Troubleshooting

23 Technical data

23.1 Parameters

Approvals	TUV
Tests	EN IEC 61496; EN ISO 13849; EN 50178; EN 55022 The specified standards refer on the respective current version of the normative documents
Safety type	4 (EN IEC 61496)
Performance Level	PL e (EN ISO 13849)
Category	Cat. 4 (EN ISO 13849)
Safety Integrity Level (SIL)	SIL 3 (EN IEC 61508)
Marking	CE
Number of protective beams	1 or 2
Dimensions	H x W x D: 99 mm x 45 mm x 114.5 mm
Power supply	24 V DC - 15 %, + 20 %
Current consumption	Max. 160 mA (without ant external indicator lamps connected)
Safety output	Normally open contacts, force-guided Load limit current 0.01A...6.0A for 18...255V AC Load limit current 0.01A...6.0A for 18...30V DC Limit switch output 60W for 30V...250V DC External protection with < 0.6 x load limit current fast Switching frequency: max. 1/s Please note! The relay output must be protected against melting through by a fuse. The externally connected switching elements should be operated at a maximum of 60% of their nominal load capacity to avoid overload.
pnp outputs	Output voltage: Supply voltage - 2 V, output current: max. 300 mA

Table 23.1: Technical data (parameters)

Response time	30 ms
Displays	OSSD ¹⁾ status: OFF – LED red, ON – LED green "Readiness for startup" status: yellow LED Protective beam status: one yellow LED per beam Error status: 7-segment display (the "Readiness for startup" LED also flashes)
Inputs (push button connections, relay monitor)	Input resistance approx. 2.2 kOhm Voltage: Operating voltage - 1 V Current: Approx. 10 mA
Activation time push button connections	0.05 - 1 s
Connection	Screw terminal, cross-section of line 0.2 ... 2 mm ²
Cable lengths	Max: 100 m
Protection class	IP 20, IP54 must be ensured for operation by installation housing
Housing	Polyamide PA 6.6, UL94, V0, black
Operating temperature / storage temperature.	0 ... 50°C/-20 ... 70°C
Relative humidity	Max. 95%, non-condensing ²⁾
Weight	230 g

Table 23.1: Technical data (parameters)

1) OSSD: **o**utput **s**ignal **s**witching **d**evice, in accordance with EN 61496-1, IEC 61496-1

2) applies at temperature of 20 °C to maximum of 50 °C



The power supply must meet the requirements for safe isolation of SELV/PELV-circuits!

23.2 Dimensions

Figure 23.1: Dimensions of SC4-2

23.3 Accessories

Power pack

Used to operate the SC4 control system with power supply by means of alternating current. The housing of the power pack has a width of 22.5 mm and is comparable in its other dimensions to the housing of the control unit.

Designation SC PS 120-230 VAC

23.4 Ordering information

Designation SC4-2 24 VDC

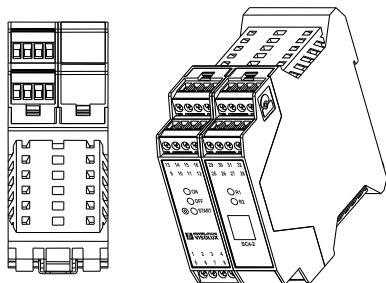

CPU-Print up to grating: approx. 145

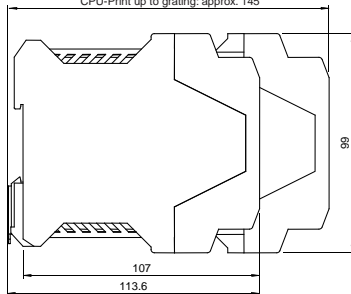
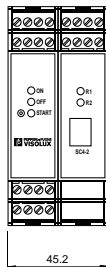

24 Sample circuits for SC4-2

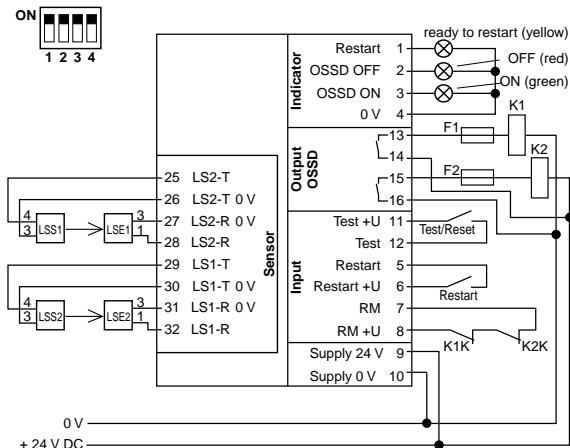

Figure 24.1: 2-beam protection with relay monitor (RM) and start/restart interlock (RI)



The additional circuitry of the K1 relay for limiting counter EMC is not represented.

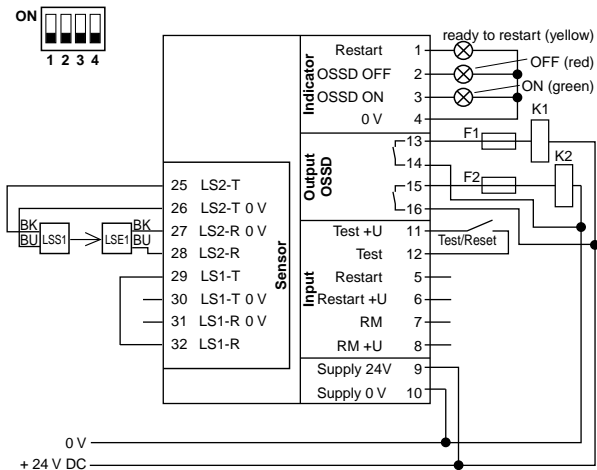

Figure 24.2: One-beam protection without relay monitor (RM) and without start/restart interlock (RI)



The start / restart interlock as well as monitoring of the function of the externally represented relay should be performed by the post-processing circuitry. The additional circuitry of the K1 relay is not represented.

25 Glossary

Startup/restart lock	A mechanism that prevents the OSSDs from being turned on after the protective field has become free.
Electrosensitive protection device	Electrosensitive protection equipment, german: BWS
EDM	External device monitoring, normally closed contact of safety components downstream in the circuit, that reports switching of the dangerous action to the SC4-2; also: Relay monitor
Function reserve	The distance from the receiver signal of the photoelectric detector to the lower limit of the switching point photoelectric detector
OSSD	Output switching elements of the electrosensitive protection device (output signal switching device in accordance with EN 61496-1)
Reset	Reset the electrosensitive protection device to its starting status
Restart	Enabling of electrosensitive protection device startup from status of startup/restart lock
Test	Input for initiating a complete test of the electrosensitive protection device including the OSSD outputs.
RM	Abbreviation for Relay Monitor; see also EDM
RI	Abbreviation for Restart Interlock; see also Restart

Table 25.1: Glossary

26 Standards

The relevant laws and standards apply to the use of photoelectric protective devices. There are differences depending on the area of use. The following regulations are relevant within the EU and Germany.

26.1 Construction and equipping of protective equipment

IEC 61496-1	Safety of machinery. Electro-sensitive protective equipment
IEC 61508,	Functional safety of EEPE safety-related systems
DIN V VDE0801	Principles for computers in systems with safety tasks
DIN EN 62061	Safety of machinery - Functional safety of safety-related electrical, electronic and programmable electronic control systems

26.2 Use and installation of protective equipment

IEC 50178	Electronic equipment for use in power installations
DIN IEC 68	Electrical engineering; basic environmental testing procedures
DIN EN 60204-1	Safety of machinery - electrical equipment of machines
DIN EN 61140	Protection against electric shock - common aspects for installations and equipment (IEC 61140:2001 and A1:2004, modified)
DIN EN 60664-1	Coordination of the insulation of electronic equipment in low-voltage systems - Part 1: Principles, requirements and tests (IEC 60664-1:2007)
DIN EN 60068-1:1995-03	Environmental testing - Part 1: General matters and guidance

Directive 98/37/EC, from 29.12.2009 Directive 2006/42/EC	Machinery Directive
EN ISO 12100	Safety of machinery - electrical equipment of industrial machines
EN ISO 13849-1	Safety of machinery - safety relevant parts of controls- part 1: General design principles
DIN CLC/TS 62046, preliminary standard, 2005-09	Safety of machinery - Use of protective equipment to recognize the presence of people (IEC/TS 62046:2004) Safety of machinery - The positioning of protective equipment with respect to approach speeds of parts of the human body
EN999/EN ISO 13855	Safety of machinery - The positioning of protective equipment with respect to approach speeds of parts of the human body
ZH1/597	Safety rules for non-contact protective equipment on powered equipment
EN ISO 13857	Safety of machinery - Safety distances to prevent hazard zones being reached by upper and lower limbs

In addition to the stipulations listed there may be other applicable standards for special machinery and applications that should be considered.



27 **Notes**

With regard to the supply of products, the current issue of the following document is applicable: The General Terms of Delivery for Products and Services of the Electrical Industry, published by the Central Association of the Electrical Industry (Zentralverband Elektrotechnik und Elektroindustrie (ZVEI) e.V.) in its most recent version as well as the supplementary clause: "Expanded reservation of proprietorship"

FACTORY AUTOMATION – SENSING YOUR NEEDS



Worldwide Headquarters

Pepperl+Fuchs GmbH · Mannheim · Germany
E-mail: fa-info@pepperl-fuchs.com

USA Headquarters

Pepperl+Fuchs Inc. · Twinsburg, OH · USA
E-mail: fa-info@us.pepperl-fuchs.com

Asia Pacific Headquarters

Pepperl+Fuchs Pte Ltd · Singapore
Company Registration No. 199003130E
E-mail: fa-info@sg.pepperl-fuchs.com

www.pepperl-fuchs.com

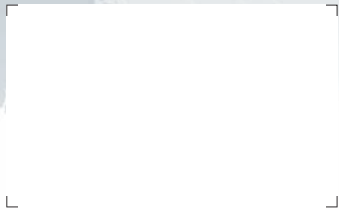

 **PEPPERL+FUCHS**
SENSING YOUR NEEDS

119701

TDOCT-0260A