



FACTORY AUTOMATION

MANUAL

SPEED MONITOR

KFU8-DW-1.D



With regard to the supply of products, the current issue of the following document is applicable: The General Terms of Delivery for Products and Services of the Electrical Industry, published by the Central Association of the "Elektrotechnik und Elektroindustrie (ZVEI) e.V. in their most recent version as well as the supplementary clause: "Extended reservation of title".

We at Pepperl+Fuchs recognise a duty to make a contribution to the future,
For this reason, this printed matter is produced on paper bleached without the use of chlorine.

1	Technical description	2
2	Operation	4
2.1	Operating mode	4
2.2	Setting mode	5
3	Technical data	11
4	Terminal assignment	12
5	Dimensions, operating and display devices	12
6	Connection plan	13
7	Function description overview	14

1 Technical description

The KFU8-DW-1.D is a device used to indicate and monitor periodic signals which occur in almost all areas of automation and process engineering, i.e. frequencies in general and rotational speeds in particular.

The input signals are evaluated using the cycle method, i.e. by measuring the duration of a period, and then converted by a very fast m-controller to frequency, or rotational speed.

The frequently occurring special case of rotational speed measurement was given particular attention. For this reason, indications and inputs can be either in Hz or in rpm.

In addition, the possibility exists, on applications involving lengthy processes, whose sensors provide a number of pulses per revolution, to operate automatically with the actual rotational speed of the drive, by presetting the number of pulses.

Indication of the measured value is achieved by means of a 4-digit 7-segment-LED-display on the front of the device, with up to 3 places following the decimal point.

The monitoring function is actuated by a limiting value, whose upper and lower hysteresis values can be selected within the appropriate measuring and indicating range.

The output signal is generated by a change-over relay when the hysteresis limits are either exceeded or fallen below. Due to its high switching capability, the relay output can be used to directly drive an actuator, or as an input signal to a higher level control.

In addition, the switching state of the relay is indicated by a yellow LED on the front face of the device.

A function block is connected in line with the output relay, which enables 10 different timer functions to be employed; thus there is no need to connect a separate timer relay in series. In addition to ON delay and OFF delay, defined ON time and pulse lengthening, the direction of operation of the relay, i.e. to monitor underspeed or overspeed, can also be selected. The built-in start-up bypass, triggered by switching on the supply voltage, or by an external signal, prevents false signals from occurring during the start-up of the monitored system.

The speed monitor may be supplied with 115 V AC, 230 V AC or 24 V DC. When an alternating voltage is connected, a 24 V DC source is available for the signal transducer.

All currently available two-, three- or four-wire proximity switches and incremental rotary encoders are acceptable as the sensor. Moreover two terminals are reserved for the connection of proximity switches to DIN 19234 (NAMUR).

Safety notes:

Insulation co-ordinates for specifying data on galvanic/electrical isolation are in accordance with DIN EN 50178:

The KFU8-DW-1.D device is intended for use in enclosed electrical operating areas, to which only competent electrical personnel or properly instructed electrotechnical personnel have access or entry.

The device is rated for use in conditions of pollution severity class 2, overvoltage category II in accordance with EN 50178.

The device comprises 3 galvanically isolated circuits:

- 230 V, 115 V voltage supply circuit, connections: 16, 17, 18
- Signal circuit
- 24 V voltage supply, connections: 4, 5
- Sensor/signal, connections: 1, 2, 3, 7, 8, 9, 13, 14, 15
- Relay output circuit, connections: 10, 11, 12

There is no isolation between the signal circuit connections and the exposed/contactable surfaces.

2 Operation

2.1 Operating mode

Signal frequency

The speed monitor processes input signals from 0.001 Hz ... 5000 Hz, over 4 measuring ranges, i. e., cycle durations of 0.0002 s to 1000 s are evaluated. Signals not having a duty rate of 1:1 must have a minimum pulse pause or pulse duration of 20 µs in order to be detected with certainty behind the input filter.

Signal has fallen below the measuring range, message

This message appears either when no input signal is detected, or if the displayed value would be zero, due to the selection of a measuring range which is too high.

Example: The device receives a signal of 0.1 Hz in the 0 Hz to 5000 Hz measuring and display range. This implies that the display would indicate zero and an observer might presume that the machine had stopped.

Signal is above the measuring range, message

The set display and measuring range has been exceeded.

Solution: Select a larger measuring range.

Very low signal frequencies, displayed value is not valid, message

During the measurement of very low signal frequencies, the measuring system has detected that the signal has fallen below the last computed frequency, i.e., the time between the last two signal edges has already elapsed. The unit is now waiting for the next positive signal edge, in order to be able to compute the next measured value. Here, 'XXX' represents the positions of the first three digits of the last measured value.

Self test, message

When the supply voltage is switched on, the speed monitor carries out a self test. The message appears when it is established that there is an error, for example during the check summation of the EEPROM data; in this state, the output relay behaves as if there has been a power failure. The error message can be cleared by switching the supply voltage off and then on again.

If, on switching on again, the error message U-01 appears, then the factory presets were loaded, i.e., the parameters must be newly entered. In order to restore the normal function of the output relay, the speed monitor must once again be switched off and then on.

2.2 Setting mode

(see also the operating summary on the fold-out page)

Password protection 

The password protection function is not active. The password can be displayed, but not changed.

Function selection 

Two measuring functions are available:

1. Frequency measurement in Hz

The period of duration of the input signal, as determined, is converted to a frequency in Hz by forming the reciprocal value and then displayed. The hysteresis limits of the switch point are also specified in Hz.

2. Rotational speed measurement in rpm (preset at the factory)

The signal frequency, derived from the period of duration, is multiplied by 60 and displayed as rpm. The hysteresis limits are likewise specified in rpm.

Pulse divider 

(Preset at the factory: 1 pulse/revolution)

Applications involving slow processes are frequently equipped with sensors which provide several pulses per revolution. In the rotational speed measuring function, the device undertakes the conversion to the actual value of rpm by inputting the numerical value (of pulses/revolution), i.e. both the indication and the input of the hysteresis limits are directly obtained from the actual rate of rotation of the drive.

Example:

In normal operation, a machine rotates at 450 rpm. An incremental rotary encoder providing 10 pulses per revolution is used as the rate of rotation sensing element.

The input frequency is

$$\frac{450 \text{ rpm} \times 10 \text{ pulses per revolution}}{60 \text{ s/min}} = 75 \text{ Hz}$$

A rate of rotation of 450 rpm x 10 pulses/revolution = 4500 rpm would be displayed in the rotational speed measuring function.

By programming the pulse divider to 10 pulses/revolution, the display would indicate the actual drive speed of 450 rpm.

Display and measuring range

(Preset at the factory: 0 ... 999.9)

Four measuring and display ranges are available for frequency measurement and three measuring and display ranges are available for speed measurement, as follows:

Display in parameter editor	Frequency range in Hz	Rotational speed in rpm	Number of decimal places
0000	0 ... 5000	0 ... 9999	0
000.1	0,0 ... 999,9		1
00.02	0,0 ... 99,99		2
0.003	0,0 ... 9,999	----	3

Example (continued from above):

The maximum permissible rotational speed of the drive is 600.5 rpm.

The first two measuring ranges can be selected. However, in order to fully utilise the accuracy of the display, it is recommended that the second measuring range is used.

Message

This message appears when an attempt has been made to change the range in such a way, that previously input limiting values lie outside the display and measuring range, or the respective places following the decimal point would be cut off.

Example (continued from above):

The maximum permissible value of 600.5 rpm has already been input as the upper hysteresis limit, and an attempt is being made to change the range to 0.01 rpm to 99.99 rpm (the limiting value is outside the display and measuring range), or an attempt is being made to change the range to 0 rpm to 9999 rpm (places following the decimal point would be cut off).

Output relay switch points

(Preset at the factory: 1 and 2)

The output relay switch points are defined by the upper and lower hysteresis limit. When the upper hysteresis limit O_Gr is exceeded, switching is triggered and on falling below the lower hysteresis limit U_Gr, switch back occurs. If no hysteresis limit is desired, i.e., the output relay is required to switch both on and off at a defined rpm, the same value has to be input for both parameters.

Example (continued from above):

On exceeding the maximum permissible rotational speed of 600.5 rpm, a signal should be activated in the control room. The alarm message should then extinguish when the speed drops again to 500 rpm.

The upper hysteresis limit is to be set at 600.5 rpm, the lower at 500 rpm.

Message 

The message GrU? appears if an attempt is made to set a value for the upper hysteresis limit which is lower than the lower hysteresis limit and GrO? is displayed on a attempt to programme a value for the lower hysteresis limit which is larger than the upper hysteresis value.

Timer functions, reversal of direction of operation of the output relay

Time base for the timer functions 

(Preset at factory: 1.0 s)

A time between 0.1 s and 999.9 s can be set for the timer function of the output relay.

Timer functions and reversal of direction of operation 

(Preset at factory: 1)

The KFU8-DW-1.D speed monitor can be adjusted to any one of 10 different settings, in association with the reversal of direction of operation, in order to modify the switching behaviour of the output relay. In functions 0 to 4, the output relay is active according to the selected time function, when the upper hysteresis value is exceeded. In functions 5 to 9 the sense of operation is inverted, i.e., the relay is active below the lower hysteresis limit.

No.	Function	No.	Function
0	no timer function	5	no timer function, inverted
1	ON delay	6	ON delay, inverted
2	OFF delay	7	OFF delay, inverted
3	Defined ON time	8	Defined ON time, inverted
4	Pulse lengthening	9	Pulse lengthening, inverted

The **ON delay** has the effect of causing the timer to start when the upper hysteresis limit is exceeded and the relay to be triggered (retriggerable) when the timer has run out.

The **OFF delay** causes the relay to operate immediately when the upper limiting value has been exceeded.

Each time the measured parameter falls below the lower limit the timer is started and as soon as the timer has run out the relay drops out (retriggerable).

Defined ON time implies that the relay pulls in when the upper hysteresis limit is exceeded and drops out again after the set time (not retriggerable), independently of further variations in rpm.

Pulse lengthening is the means of providing that the relay pulls in when the upper limit is exceeded and drops out as soon as possible when the set time has elapsed (not retriggerable).

(See also the graphical representation on page 7).

Start-up bypass

(Preset at factory: 3 s)

A start-up bypass time between 0.1 s and 999.9 s can be programmed in order to avoid false signals on the start-up of a drive which is to be monitored for underspeed. During this time the device and the output relay behave as if the machine had already exceeded the upper hysteresis limit. The start-up bypass time is started by a positive signal on terminal 2; the positive signal must be at least as long as the bypass time. The start signal can originate from a higher order control, or be generated by the connection of the supply voltage to the speed monitor. In the latter case, terminals 2 and 3 have to be bridged.

Example:

In normal operation, a machine requires a maximum of 50 s to run up to a nominal speed of 500 rpm. The start-up bypass time has to be set to a value greater than 50 s. When the period of 50 s has elapsed the rpm underspeed monitoring function is active (relay function 5). If the start-up is as scheduled during this time, the relay will not have actuated. If the start-up takes longer than anticipated, then the relay will switch after commencement of the start-up bypass, until the upper hysteresis limit has been reached.

Display rate

(Preset at factory: 0.33 s)

In order to ensure good readability of the display, the time taken to indicate the current measured value in the display can be selected between 0.01 s and 2.5 s.

Software version number

The number of the software version can be read only.

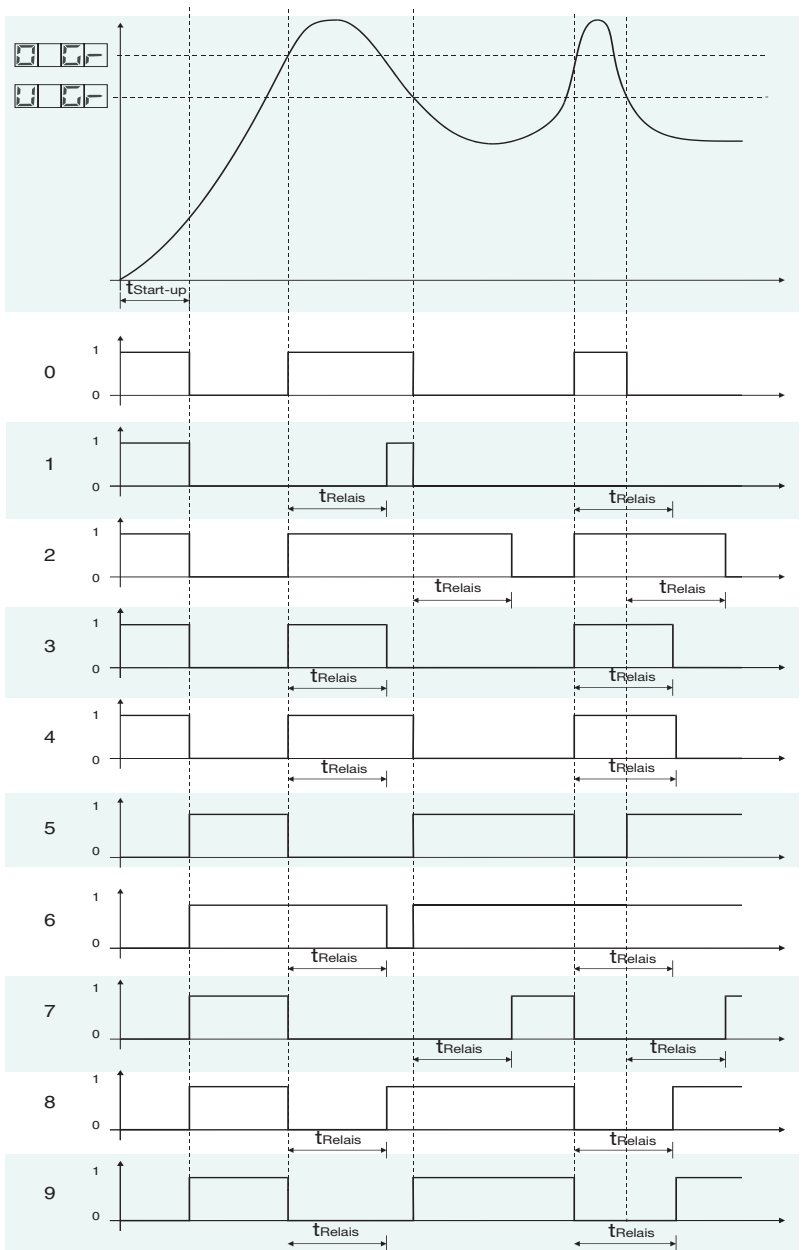

Figure: Timer functions, reversal of direction of action of the output relay

Date of issue 2003-12-08

KFU8-DW-1.D

Operation

Date of issue 2003-12-08

3 Technical data

Supply voltages	30 V AC \pm 10 %, 47 Hz ... 63 Hz, < 5 VA (Terminal 16, 18) 115 V AC \pm 10 %, 47 Hz ... 63 Hz, < 5 VA (Terminal 17, 18) 24 V DC +15/-10 %, $U_{SS} \leq 10$ %, < 5 W (Terminal 4, 5)
Signal inputs	
Frequency	0,001 Hz ... 5000 Hz Minimum pulse length/duration: 20 μ s
NAMUR	Switch points: ≥ 1.2 mA; ≤ 2.1 mA (Terminal 8, 9) No load voltage: 8.2 V; Short circuit current: 6.5 mA Impedance: 1.2 k Ω
PNP-sensor	Switch point: 12 V (Terminal 15) Max. input voltage: 30 V Impedance: 2.8 k Ω
NPN-sensor	Switch point: 12 V (Terminal 14) Impedance: 3.3 k Ω
Triggerinput	Switch point: 12 V (Terminal 2) Max. input voltage: 30 V Impedance: 2.8 k Ω
Output relay	Terminal 10: NO; Terminal 11: NC; Terminal 12: COM 250 V AC, 2 A, $\cos\phi \geq 0.7$ 40 V DC, 2 A ON/OFF delay (incl. computation time) ≤ 20 ms Mechanical life $\geq 30.000.000$ switch cycles
Switch state indicator	3 mm - yellow LED
Timer functions	ON/OFF delay, defined ON time, pulse lengthening Timer period: 0 s ... 999.9 s
Direction of operation	reversible
Sensor power supply	Terminal 3, 13: L+; Terminal 1, 7: L- 24 V DC \pm 10 %, $U_{SS} \leq 10$ %, 30 mA short circuit protected
Start-up bypass	Triggered by external signal (Terminal 2) or by switching on the supply voltage (Terminal 2 and Terminal 3 bridged) Bypass time: 0.1 s ... 999.9 s
Error of measurement	0.001 Hz ... 100 Hz: ≤ 0.1 % 100 Hz ... 1 kHz: ≤ 0.3 % 1 kHz ... 5 kHz: ≤ 1.5 % Display: ± 1 digit
Ready delay	≤ 400 ms
Display rate of rotation and frequency	4-digit 7-segment-LED-display, red, digit height: 7 mm
Design	Modular terminal housing (Macrolon), system KF
Mounting	Snap-on to a 35 mm DIN rail per DIN EN 50022 or to screw with extendable latches in a 90 mm grid
Terminal connections	Removable, encoded device terminals Cross sectional area: $\leq 2 \times 2.5$ mm ²
Operating temperature	-25 °C ... +70 °C
Storage temperature	-40 °C ... +85 °C
Pollution severity class	2
Protection class	IP 20
EMV	EN 50081-2, EN 50082-2
Overvoltage category II	in accordance with EN 50 178

4 Terminal assignment

Term. 1: Sensor power supply, GND	Term. 10: Relay normally open contact, NO
Term. 2: Trigger input for start-up bypass	Term. 11: Relay normally close contact, NC
Term. 3: Sensor power supply, 24 V DC	Term. 12: Relay root, COM
Term. 4: Power supply, 24 V DC	Term. 13: Sensor power supply, 24 V DC
Term. 5: Power supply, GND	Term. 14: for NPN-sensor Input
Term. 6: Not connected	Term. 15: for PNP-sensor Input
Term. 7: Sensor power supply, GND	Term. 16: Power supply L1, 230 V AC
Term. 8: NAMUR input L -	Term. 17: Power supply L1, 115 V AC
Term. 9: NAMUR input L	Term. 18: Power supply N

5 Dimensions, operating and display devices

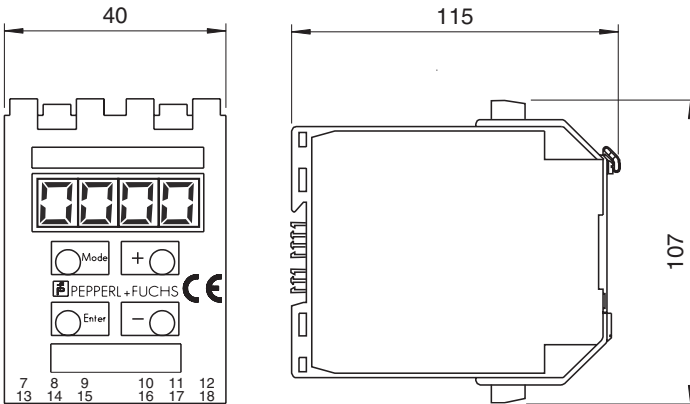

- "Mode" and "+": Start parameterization editor
- "+": Advance to next parameter selection or increase the flashing digit by one
- "-": Return to previous parameter selection or decrease the flashing digit by one
- "Mode": Display parameter value (right character flashes) or shift the flashing character to the left
- "Enter": Exit parameter value display, the device now works temporarily with the altered parameter.
- "Enter" and "+": Exit parameter editor, the parameters are now permanently stored in the EEPROM.

Date of issue 2003-12-08

6 Connection plan

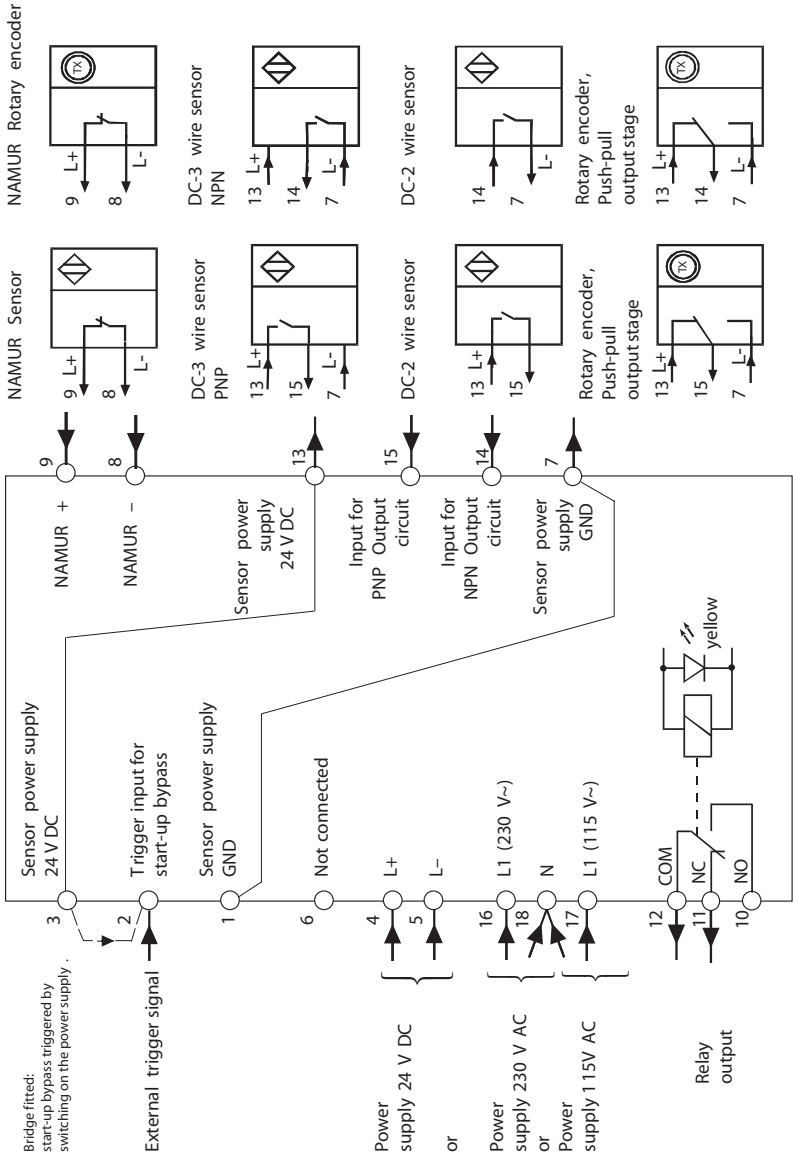

Date of issue 2008-12-08

7 Function description overview

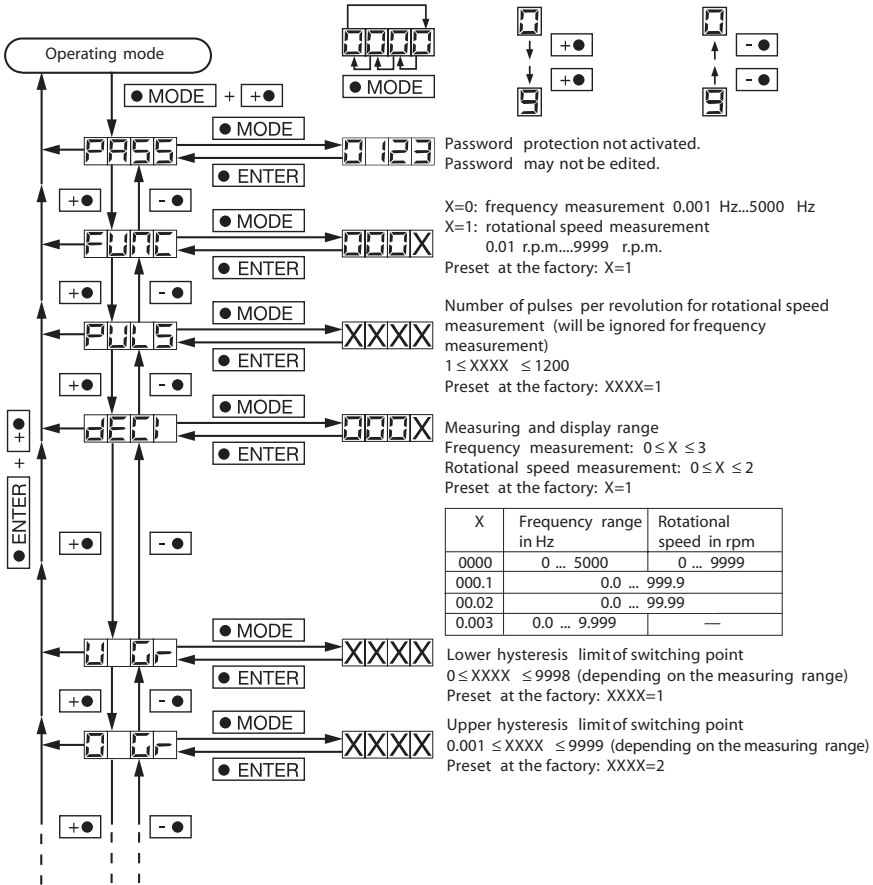

Date of Issue 2003-12-08

KFU8-DW-1.D

Function description overview

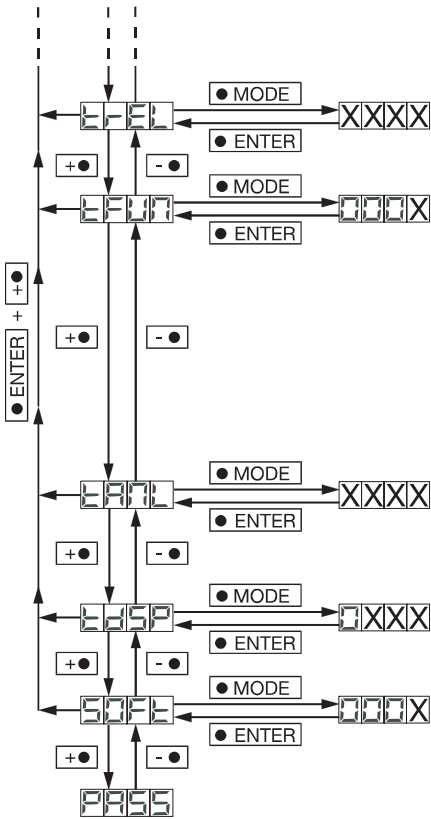

Period for the timer function of switching relay
 $0.1 \text{ s} \leq \text{XXX.X} \leq 999.9 \text{ s}$
 Preset at the factory: $\text{XXX.X}=1.0 \text{ s}$

Period for the timer function of switching relay
 Preset at the factory: $\text{X}=1$

X	Function
0	No timer function
1	ON delay
2	OFF delay
3	Defined ON time
4	Pulse lengthening
5	No timer function, inverted
6	ON delay, inverted
7	OFF delay, inverted
8	Defined ON time, inverted
9	Pulse lengthening, inverted

Start-up bypass
 $0.1 \text{ s} \leq \text{XXX.X} \leq 999.9 \text{ s}$
 Preset at the factory: $\text{XXX.X}=3.0 \text{ s}$

Display rate
 $0.01 \text{ s} \leq \text{XX.X} \leq 2.5 \text{ s}$
 Preset at the factory: $\text{XX.X}=0.33 \text{ s}$

The number of the software version
 can be read only.

KFU8-DW-1.D

Function description overview

Date of issue 2003-12-08

With regard to the supply of products, the current issue of the following document is applicable: The General Terms of Delivery for Products and Services of the Electrical Industry, published by the Central Association of the "Elektrotechnik und Elektroindustrie (ZVEI) e.V. in their most recent version as well as the supplementary clause: "Extended reservation of title".

We at Pepperl+Fuchs recognise a duty to make a contribution to the future,
For this reason, this printed matter is produced on paper bleached without the use of chlorine.

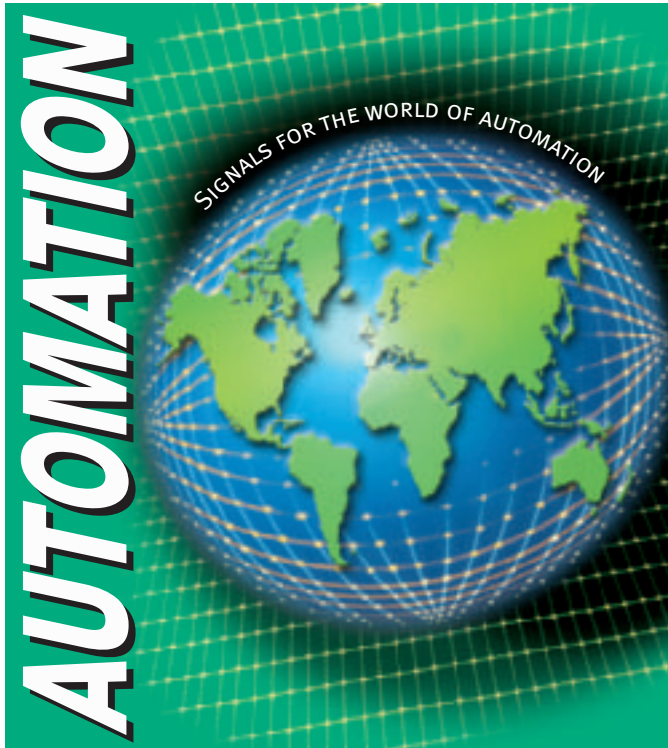

www.pepperl-fuchs.com

Worldwide Headquarters

Pepperl+Fuchs GmbH · Königsberger Allee 87
68307 Mannheim · Germany
Tel. +49 621 776-0 · Fax +49 621 776-1000
e-mail: info@de.pepperl-fuchs.com

USA Headquarters

Pepperl+Fuchs Inc. · 1600 Enterprise Parkway
Twinsburg, Ohio 44087 · Cleveland-USA
Tel. +1 330 4253555 · Fax +1 330 4 25 93 85
e-mail: sales@us.pepperl-fuchs.com

Asia Pacific Headquarters

Pepperl+Fuchs Pte Ltd. · P+F Building
18 Ayer Rajah Crescent · Singapore 139942
Tel. +65 67799091 · Fax +65 68731637
e-mail: sales@sg.pepperl-fuchs.com

 **PEPPERL+FUCHS**
SIGNALS FOR THE WORLD OF AUTOMATION