



# INSTRUCTION MANUAL

## SafeBox SB4 Evaluation System

### Original Instructions



**LISTED**

AOPD  
3AA2

UL File Number: E215245



**ph** PEPPERL+FUCHS

The latest version of the General Terms of Delivery for Products and Services in the Electronics Industry set out by the German Electrical and Electronic Manufacturers' Association (ZVEI) and the "Extended Reservation of Proprietorship" supplementary clause apply.

<b>1</b>	<b>Introduction</b>	<b>7</b>
1.1	Congratulations	7
1.2	Contact	7
1.3	Symbols Used	8
<b>2</b>	<b>Declaration of Conformity</b>	<b>8</b>
<b>3</b>	<b>Safety</b>	<b>9</b>
3.1	Safety-Relevant Symbols	9
3.2	Intended Use	9
3.3	General Safety Notice	10
<b>4</b>	<b>SB4 Evaluation System Features</b>	<b>11</b>
<b>5</b>	<b>The SB4 Evaluation Device</b>	<b>12</b>
5.1	Product Description	12
5.2	Function Principle	12
5.3	Component Overview	14
5.4	Housing	15
5.5	Designation Code	15
5.6	Device Versions	16
5.6.1	Standard Versions	16
<b>6</b>	<b>Functions of the SafeBox SB4</b>	<b>20</b>
6.1	Restart	20
6.2	Relay Monitor	21
6.3	Stop Categories	21
6.4	Muting	22
6.4.1	General	22

6.4.2	Operating Principle .....	23
<b>7</b>	<b>Modules .....</b>	<b>27</b>
7.1	SB4 Basic Module OR .....	27
7.1.1	Function .....	27
7.1.2	Connections .....	27
7.1.3	Connection Assignment .....	28
7.1.4	Settings .....	29
7.1.5	Indicators .....	30
7.2	SB4 Function Module 2E .....	33
7.2.1	Function .....	33
7.2.2	Connections .....	33
7.2.3	Connection Assignment .....	34
7.2.4	Settings .....	37
7.2.5	Indicators .....	39
7.3	Muting Module 4M .....	40
7.3.1	Function .....	40
7.3.2	Muting Sensors .....	41
7.3.3	Muting Lamps .....	41
7.3.4	Emergency Muting (Override) .....	42
7.3.5	Double Muting .....	43
7.3.6	Connections .....	46
7.3.7	Settings .....	48
7.3.8	Indicators .....	49
7.4	4-Channel or 6-Channel Sensor Modules (*C*) .....	50
7.4.1	Function .....	50
7.4.2	Connections .....	50
7.4.3	Connection Assignment .....	52
7.4.4	Settings .....	55

7.5	4-Channel Sensor Module (4X*)	56
7.5.1	Function	56
7.5.2	Connections	59
7.5.3	Connection Assignment	61
7.5.4	Settings	64
7.6	Basic Housing and Accessories	65
7.7	Mounting Notes for Modules and Basic Housings	66
<b>8</b>	<b>Setup and Mounting of the Light Barriers and Light Grids</b>	<b>67</b>
<b>9</b>	<b>Installation</b>	<b>71</b>
<b>10</b>	<b>Commissioning</b>	<b>72</b>
10.1	Adjusting Protection Beams	72
10.2	Function Test	72
10.2.1	Testing the Detection Capacity of the Installed Electro-Sensitive Protective Equipment	72
10.2.2	Checking the Sensors and Stop Functions	72
10.2.3	Checking Other Connected Safety Devices	72
10.2.4	Checking the Muting Function	73
<b>11</b>	<b>Periodic Inspection</b>	<b>73</b>
<b>12</b>	<b>Fault Repair</b>	<b>74</b>
<b>13</b>	<b>Technical Data</b>	<b>77</b>
13.1	Functional Safety Data	77
13.2	Conformity with Standards And Directives	77
13.3	Approvals and Certificates	78
13.4	Parameters	78
13.5	Dimensions	83
<b>14</b>	<b>Application Checklist</b>	<b>85</b>

14.1	Before Installation .....	85
14.2	After Installation .....	85
14.3	Commissioning .....	86
14.4	Periodic Inspection .....	86
<b>15</b>	<b>Ordering Information .....</b>	<b>87</b>
15.1	Devices .....	87
15.2	Modules .....	88
<b>16</b>	<b>Glossary .....</b>	<b>89</b>

## 1 Introduction

### 1.1 Congratulations

You have chosen a device from Pepperl+Fuchs. Pepperl+Fuchs develops, produces, and markets electronic sensors and interface modules worldwide for the automation technology market.

Please read the instruction manual carefully before installing this device and putting it into operation. The instructions and notes in this document will guide you step by step through the mounting and commissioning procedures to ensure trouble-free use of this product. By following the instructions in this manual, you:

- Guarantee safe operation of the device
- Can utilize the entire range of device functions
- Avoid faulty operation and associated errors
- Reduce costs associated with downtime and incidental repairs
- Increase the effectiveness and economic efficiency of your plant.

Store this instruction manual somewhere safe to ensure it is available for future work on the device.

Directly after opening the packaging, ensure that the device is intact and that all items are included.

### 1.2 Contact

If you have any questions about the device, its functions, or accessories, contact us at:

Pepperl+Fuchs Group

Lilienthalstraße 200

68307 Mannheim

Germany

Phone: +49 (0)621 776-1111

Fax: +49 (0)621 776-271111

Email: [fa-info@de.pepperl-fuchs.com](mailto:fa-info@de.pepperl-fuchs.com)

### 1.3 Symbols Used

The following symbols are used in this manual:



**Note!**

You will find important information beside this symbol.

## 2 Declaration of Conformity

All products were developed and manufactured in line with the applicable European standards and directives.



**Note!**

A declaration of conformity can be requested from the manufacturer.

The product manufacturer, the Pepperl+Fuchs Group, 68307 Mannheim, Germany, has a certified quality-assurance system that conforms to ISO 9001.





### 3 Safety

#### 3.1 Safety-Relevant Symbols



**Danger!**

This symbol warns of an immediate and present danger.  
Failure to observe this warning may result in personal injury or even death.



**Warning!**

This symbol warns of a potential fault or hazard.  
Failure to observe this warning may result in personal injury or extensive damage to property.



**Caution!**

This symbol warns of a potential fault.  
Failure to observe this warning may result in the device and/or any systems and plants connected to it malfunctioning or failing completely.

#### 3.2 Intended Use

In connection with SLC, SLCS, and other contact-type or p-switching safety switch elements, SLA light barriers, and/or SLG and SLP light grids, and SLC light curtains, the evaluation system SafeBox SB4 forms a photoelectric safety device. The protection beams are formed between the transmitters and receivers.



This system can be used as intended as **electro-sensitive protective equipment** to secure danger zones or hazardous areas from unauthorized entry or as a safety control unit for safety components according to the conditions described. If used for any other purpose, the intended function of the system cannot be guaranteed.

The applicable safety regulations, standards, and provisions must be observed when operating the system, and the specific requirements of the application in question must be taken into consideration.

### 3.3 General Safety Notice

The device must be operated only by trained and qualified personnel, in accordance with this instruction manual.

The following basic instructions must be observed at all times:

- The device must not be commissioned until the manual has been read and understood
- The device must not be used out of specification without suitable safety measures
- Tampering with the device is not permitted
- Do not remove the warnings or nameplates

Before selecting and using the product, an assessment must determine whether it is suitable for the application in question. Pepperl+Fuchs has no influence on the selection and use of this product. Liability is therefore restricted to the consistent quality of the product.

The product must be regularly checked and maintained by specialist personnel. The inspection and maintenance results must be logged. Only original spare parts from Pepperl+Fuchs may be used for repairs.

The operator is responsible for complying with all local safety regulations.

If you open or modify the device yourself, not only are you endangering yourself and others but you will void any warranty, the manufacturer's liability and the examination certificate. Switch off the device if any serious faults occur. Make sure that the device cannot be inadvertently switched on again. If the device needs to be repaired, return it to Pepperl+Fuchs.



**Note!**

Avoid electrostatic discharge through unprotected contact with the assemblies. Components destroyed by electrostatic discharge will render the warranty null and void.



**Note!**

Observe the laws and guidelines applicable for the use or the intended purpose. The device is only approved for proper and intended use. Ignoring these instructions will void any warranty and absolve the manufacturer of any liability.

Store the device in the original packaging when not in use. This offers the device optimal protection against impact and moisture.



**Note!**

**Disposal**

Electronic waste is hazardous. When disposing of the equipment, observe the current statutory requirements in the respective country of use and the local regulations.

#### 4 SB4 Evaluation System Features

The SB4 evaluation system is a piece of electro-sensitive protective equipment of type 4 (EN IEC 61496-1) or category 4 (EN ISO 13849).

This system has also been designed and tested in accordance with IEC 61508. The system meets the requirements of SIL 3.

**System properties:**

- 7-segment display for easy fault diagnosis
- Yellow LED per input channel for status indication and fault indication
- Easy selection of operating modes by DIP switch

## 5 The SB4 Evaluation Device

### 5.1 Product Description

Together with the light barriers, the SafeBox SB4 evaluation device forms a single- or multi-beam photoelectric safety device that can be used to protect hazardous areas. The device meets the requirements of a safety control unit in accordance with category 4 PL e of EN ISO 13849 for contact-type or p-switching safety switch elements. It consists of several modules that can be combined as intended and accommodated in a module rack with two or max. eight slots.

### 5.2 Function Principle

The SafeBox has a modular design and its basic configuration includes two plugin modules, which are housed in a subrack with a backplane. The system automatically detects the function of the modules. Neither addressing nor programming is necessary. Unused slots remain free and are available for later upgrades. Alternatively, you can use a smaller subrack with two, three, four, five, six, or eight slots.

In its basic configuration to monitor just one hazardous area, you must use the OR module in combination with a CP or XP module.

After switching on the evaluation device, the sensors connected to sensor modules 4C and 6C are read in. If a light barrier is connected to an input, the channel is operated as light barrier. If the input is open or connected to the corresponding transmitter output, the system regards the connected sensor as a switch.

You can define the sensor types that can be connected to the 4X modules via DIP switch. If the sensor type changes during operation, e.g., due to wire break at a light barrier, this leads to an error.

The OR module holds the supply voltage for the SafeBox. It has two safe outputs and enables a category 0 emergency stop. This defines an uncontrolled shutdown with immediate interruption of the energy supply in accordance with EN 60204. The OR module has inputs for resetting, restarting, and a disconnectable relay monitor to monitor downstream contacts, and the required connections for signaling devices. As well as a red, yellow, and green signal LED, the device has a 7-segment display for displaying error codes. You can easily locate the error with the flashing LED on the channel of the module in question.

After the cause has been eliminated, errors can be confirmed by actuating the reset input or by reconnecting the voltage.

The CP and XP modules have four input channels. The safety-oriented microprocessor control continuously monitors the function of all connected safety elements and the internal safety system and switches the allocated safe outputs of the OR module. Two adjacent channels can be monitored for simultaneity or for exclusive OR function. You can increase the number of channels by adding a 4C, 4X, or 6C module. It is possible to put multiple modules in a row. You can therefore add up to 32 channels.

Protective equipment such as an emergency switching off device, contact strips, switching mats, magnet-operated switches, light barriers, light grids, light curtains, etc. can be switched on with the appropriate module of type "C" or "X."

In addition to the pure emergency switching off device, the SafeBox offers additional functions via the 2E and 4M modules.

For example, the 2E module can perform a delayed switch-off with setting Stop 1. This allows a motion to come to a safe stop before the voltage for this area is completely removed. If you need to apply different delay times, you can use multiple 2E modules.

With the 4M module you can implement the conventional muting applications. Plug it in directly behind the sensor module that holds the protective equipment that you want to mute. The 4M module supports four muting operating modes and allows you to connect two muting lamps.

Only a few simple rules must be observed for the SafeBox: There are DIP switches for module-related functions such as relay delay times, while the position of the modules defines the logic of the interaction. Since each type of module is provided with a fixed identifier in the factory, the system can uniquely identify and address each module by its ID and its slot number.

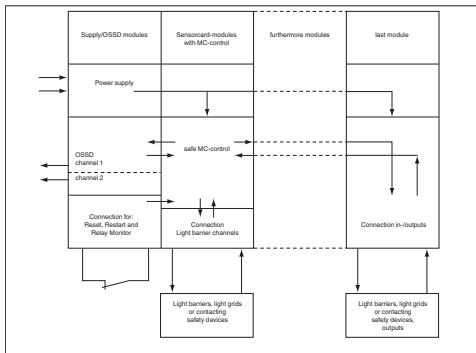

Figure 5.1: Device structure, schematic

### 5.3 Component Overview

Depending on the configuration, the electro-sensitive protective equipment or safety device of the SafeBox SB4 versions described here consists of:

- An SB4 evaluation device ... with a minimum of two modules (OR and 4CP or 4XP module) and a maximum of eight modules (additional 4C or 4X, 2E, or 4M modules)
- One or more SLA12 or SLA29 light barriers or SLG light grids (\*C\* modules) and/or
- One or more SLA 5 (S) or SLA40 light barriers or SLP light grids (4X\* modules) and/or
- Contact-type safety devices
- P-switching safety devices with their own cross-bridging monitoring, e.g., SLC and SLCS or SLCT light curtains
- Switching mats according to the 4-wire principle

Depending on the number and type of the sensor modules, up to 32 light barriers can be controlled. There are 4-channel and 6-channel sensor modules. Each evaluation device contains a voltage supply assembly, which generates the switch-off signals, and a sensor module, which contains the microprocessor control of the system. This sensor module has four sensor channels.

#### 5.4 Housing

The SB4-... is in a housing for DIN rail mounting. The installation width is a minimum of 45.2 mm for a device with two modules and 180.8 mm for a device with a maximum of eight modules.

The housing can have two to eight slots. The left slot has the number 1. The other slots follow on the right.

#### 5.5 Designation Code

The designation of the individual SafeBox versions is structured such that the device structure is immediately obvious. For each assembly used, the module type of the respective assembly is stated starting from the left.

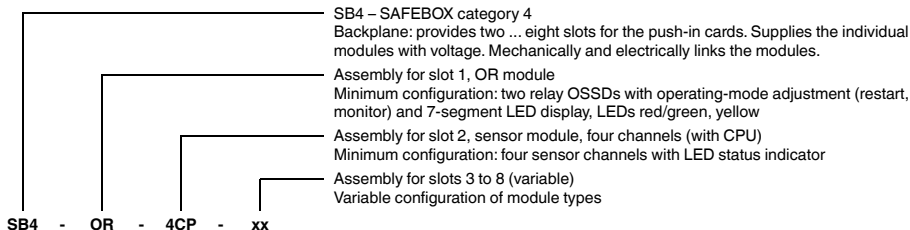

Short code	Model name	Description
OR	SB4 Module OR	SB4 basic module with two safety switching outputs and diagnostics
4CP	SB4 Module 4CP	SB4 sensor module with processing unit for four sensors, e.g., Pepperl+Fuchs 2-wire safety light barriers, sensors with NC contacts
4C	SB4 Module 4C	Same as SB4 Module 4CP, but without processing unit
6C	SB4 Module 6C	Same as SB4 Module 4C, but connectivity for six sensors
4XP	SB4 Module 4XP	SB4 sensor module with processing unit for four sensors, e.g., Pepperl+Fuchs 3-wire safety light barriers, sensors with PnP semiconductor outputs
4X	SB4 Module 4X	Same as SB4 Module 4XP, but without processing unit
4M	SB4 Module 4M	SB4 muting module for two, four, or 2x2 muting sensors. Supports parallel, sequential, double muting, protection-beam-limiting muting, override
2E	SB4 Module 2E	SB4 function module, STOP 0, STOP 1, central emergency switching off device

## 5.6 Device Versions

### 5.6.1 Standard Versions

Pre-assembled SB4 evaluation devices are available for the implementation of typical electro-sensitive protective equipment applications. These are suitable for access protection at one or more entrances to hazardous areas.



#### 5.6.1.1 4-Channel Evaluation Device SB4-OR-4CP

A maximum of four safety light barriers can be connected to this evaluation unit, e.g., the 2-wire SLA12 or SLA29 light barriers. Other contact-type safety devices can be connected instead of the light barriers.

The startup / restart lock is activated at the factory.

Changing the DIP switch setting makes self-acknowledging operation possible.

Figure 5.2: Front view of SB4-OR-4CP

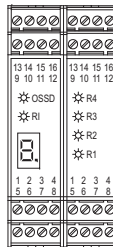

#### 5.6.1.2 8-Channel Evaluation Device SB4-OR-4CP-4C

The SB4-OR-4CP-4C is suitable for connecting one ... eight safety light barriers and is the extension of the SB4-OR-4CP by four connections. The large number of sensor channels makes this evaluation device suitable for protecting several entries.

Other contact-type safety devices can be connected instead of the light barriers.

The startup / restart lock is activated at the factory. Changing the DIP switch makes self-acknowledging operation possible.

Figure 5.3: Front view of SB4-OR-4CP-4C

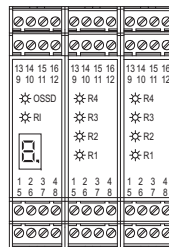

### 5.6.1.3 4-Channel Evaluation Device with Muting SB4-OR-4CP-4M

This evaluation device is suitable for muting applications of one ... four safety light barriers. The adjustment options via the DIP switches of the muting module enable optimal customization to the application.

For example, the double muting operating mode with an evaluation device can implement muting on two entries to the hazardous area that are protected by two protection beams. The protection beams of light barrier channels 1 and 2 are muted with muting sensors 1 and 2, channels 3 and 4 are muted with muting sensors 3 and 4 (see module description section 7.3). The startup / restart lock is activated at the factory.

Changing the DIP switch setting makes self-acknowledging operation possible.

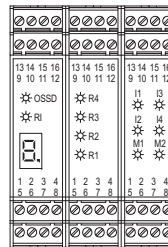

Figure 5.4: Front view of SB4-OR-4CP-4M

#### 5.6.1.4 4-Channel Evaluation Device SB4-OR-4XP

Safety light grids of type SLP with a maximum of four protection beams or 3-wire safety light barriers (e.g., SLA5) can be connected to this evaluation device. Instead of light barriers you can connect switching mats, contact strips, and 2-channel p-switching safety devices with their own cross-bridging monitoring, e.g., compatible SLPC, SLPCM safety light grids, or SLC safety light curtains.

The startup / restart lock is activated at the factory.

Changing the DIP switch setting makes self-acknowledging operation possible.

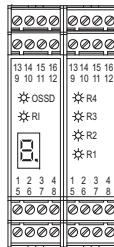

Figure 5.5: Front view of SB4-OR-4XP

#### 5.6.1.5 8-Channel Evaluation Device SB4-OR-4XP-4X

The SB4-OR-4XP-4X is the same as the SB4-OR-4XP, but with four extra channels. The large number of sensor channels makes this evaluation device suitable for protecting several entries.

The startup / restart lock is activated at the factory.

Changing the DIP switch setting makes self-acknowledging operation possible.

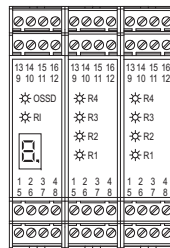

Figure 5.6: Front view of SB4-OR-4XP-4X

#### 5.6.1.6 4-Channel Evaluation Device with Muting SB4-OR-4XP-4M

This evaluation device is suitable for muting applications of one to four safety light barriers. The adjustment options via the DIP switches of the muting module enable optimal customization to the application. You can mute safety light curtains with two cross-bridging-monitored outputs (e.g., SLC series) with this evaluation device.

For example, the double muting operating mode with an evaluation device can implement muting on two entries to the hazardous area that are protected by two protection beams. The protection beams of light barrier channels 1 and 2 are muted with muting sensors 1 and 2, channels 3 and 4 are muted with muting sensors 3 and 4 (see module description section 7.3).

The startup / restart lock is activated at the factory.

Changing the DIP switch setting makes self-acknowledging operation possible.

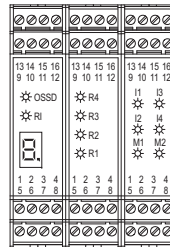

Figure 5.7: Front view of SB4-OR-4XP-4M

## 6 Functions of the SafeBox SB4

The SafeBox SB4 offers a variety of functions. A function is assigned to a module. Here is a general description of the function.

### 6.1 Restart

The restart function can optionally be activated or deactivated with DIP switches. If the function is deactivated, the OSSDs switch on after voltage connection and activated safety inputs or after all safety inputs have been activated. If the restart function is activated, the user must actuate a start key (normally closed contact) before switching on the OSSDs.

This applies after voltage connection and after initiation of a safety input.

## 6.2 Relay Monitor

With the OSSD switching outputs, the OR or 2E modules can, with the help of feedback contacts, perform safety-relevant monitoring of external switching elements that are correlated in terms of time. Normally closed contacts of force-guided relays must be used as feedback contacts. The feedback contacts of all downstream external switching elements must be switched in series. This series switching must be connected with the positive voltage supply on one side and with the relay-monitor input on the other side.

The feedback contacts of the external switching elements must guarantee a reliable contact at a voltage of 20 V and a current of 5 mA. A surge voltage strength of 6 kV must be guaranteed between the feedback contacts and other contacts connected to a low voltage according to the Low Voltage Directive.

The external switching elements are monitored with a delay of 200 ms after the switching operation. If the new switching status has not been adopted after the expiration of the monitoring time, the OR module goes into interlock mode, the 7-segment display shows an **F**, and the restart indicator flashes. This error can be confirmed by a reset after the cause has been eliminated.

## 6.3 Stop Categories

According to EN 60204, **stop function category 0** refers to an uncontrolled shutdown, i.e., the elements downstream of the OSSDs **immediately** interrupt the energy supply. For stop function category 1, the stop command is triggered via the OSSDs for controlled stopping. The OSSD module acting as **stop function category 1** delivers the **switch-off command** for the energy supply **after** the selected **time delay** has expired.

### Stop function category 1

The 2E module with stop function category 1 switches off its OSSDs with a delay. The delay time is set via two channels by DIP switch. The control command for a controlled stop is supplied by the OSSD assembly immediately to the left, which works in stop function category 0.

The Restart function of the module is obsolete in this operating mode.

The relay monitor can optionally be activated or deactivated.

## 6.4 Muting

### 6.4.1 General

The muting operating modes allow for a bypass of the protection beams as intended.

When using a muting module in SB4, muting can be implemented according to IEC 61496-1.

If an object is to be moved through the protection beams without the beams responding, muting sensors with a sensing range both in front of and behind the protection beams are required. The sensors must be arranged in such a way that the object causing the muting is detected completely by at least two muting sensors while passing through the protection beams.

Muting requires the connection of a signal lamp or the provision of a muting status signal. A signal lamp can be monitored by the muting module. If monitoring is active and the lamp is missing or defective, the system assumes the safe state (OSSDs off).



For the North American market, remember that the muting-lamp monitoring function must be active to meet standard requirements.

In the case of a system with three modules, the muting status is reached approx. 91 ms after activation of the muting sensors. This system cancels the muting status approx. 50 ms after deactivation of the muting sensors. Further time data on the muting sensors and response times after the release of protection beams can be found in section "Technical Data."



The spatial arrangement of the muting sensors must ensure that muting can only be initiated by the added objects and not by persons. The arrangement of the muting sensors depends on the following factors:

- Specific application
- Type of muting sensors used
- Number of muting sensors
- The way the objects are added to the hazardous area
- Type and size of the objects to be added
- Speed of the objects
- Protection against the muting sensors being deceived

If muting is activated, the muting object should block the entry in the area of the protection beams such that a person cannot enter the hazardous area unnoticed.

## 6.4.2 Operating Principle

### 6.4.2.1 Evaluating the Muting Sensors through Parallel or Sequential Muting

Depending on the arrangement, the muting sensors are activated within a short time span or successively. The activation sequence can be monitored by choosing between parallel and sequential muting.

### Parallel Muting

In the parallel muting operating mode, the paired muting sensors (MS1 and MS2 or MS3 and MS4) must be activated within two seconds (simultaneity requirement). If just one of the muting sensors is activated in this time, it is blocked. The lock prevents activation of the muting. The protection beams remain active. If the system locks the muting sensors, the LEDs of the affected sensor pair flash and the 7-segment display indicates error 7.

The lock will only be removed once the sensor is no longer active. The removal of the lock resets the error indicators.

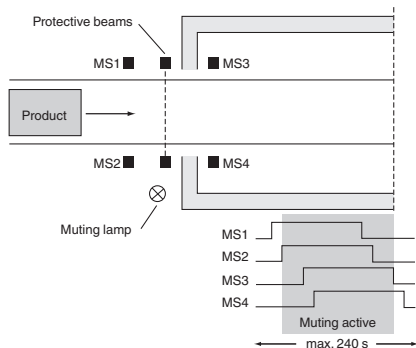

Figure 6.1: Parallel muting



### Sequential Muting

In contrast to parallel muting where the activated sensors MS1 and MS2 or MS3 and MS4 fulfill the muting condition, sequential muting also allows sensors MS2 and MS3 to keep the muting condition. The muting sensors are activated successively. Select the arrangement of the sensors such that a person cannot unintentionally activate two sensors.

Figure 6.2: Sequential muting

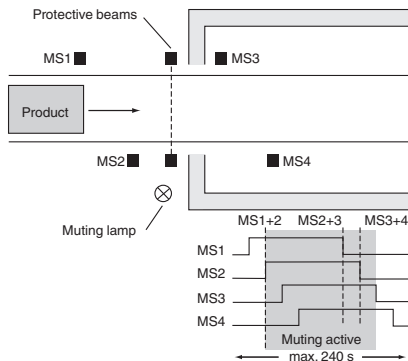

#### 6.4.2.2 Muting Monitoring by Time-Frame-Limited or Protection-Beam-Limited Muting

To avoid a dangerous continuous muting in the case of a failure of the muting sensors, muting is operated either with a time-frame limit or a protection-beam limit. You should enable time-frame-limited muting if the objects that are to pass by the protective beams unhindered normally cross through the protection beams within approx. 240 seconds. If this is not long enough, you can use the protection-beam-limited muting function. Remember that muting stops approx. 440 ms after all protection beams have been released.

### Time-Frame Limit

Time-frame-limited muting monitors each muting sensor in terms of time. Each sensor may be activated for a maximum of 240 seconds. This means that the muting object must have passed the sensor within this time. As soon as this time is exceeded, the SafeBox locks the sensor. If the sensor is locked (error **3**), it is no longer possible to activate muting. The sensor can only be released again once it has been deactivated.

Figure 6.3: Time-frame-limited muting

### Protection-Beam Limit

Protection-beam-limited muting evaluates the muting sensors with respect to time after activation. Two activated muting sensors initiate the muting procedure. At the latest 240 seconds after activation (applies separately for each muting sensor), at least one protection beam must be interrupted. In contrast to time-frame-limited muting, this condition stops the time measurement. Muting with no time limit is therefore possible. Approx. 440 ms after the protection field has been left (all protection beams have been released) and the passageway is therefore free again, all activated muting sensors are locked so that muting is no longer possible. This lock causes all activated muting sensor indicators to flash and the 7-segment display shows a **3**. This display resets after release of the muting sensors.

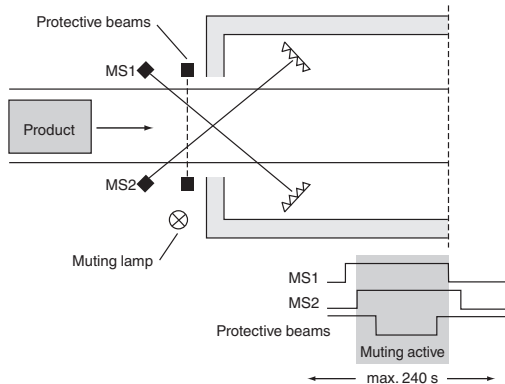

## 7 Modules

Various modules are available for the SB4 evaluation device to implement a wide range of functions. The module with the electric power supply and the first OSSDs is located on the first slot on the left. Next to it on the second slot is a module containing the sensor functionality and the system controls.

You can insert additional modules according to the required function. You can find a list of modules in chapter 15.2.

### 7.1 SB4 Basic Module OR

#### 7.1.1 Function

The OR module contains the electric power supply for the SafeBox, two OSSDs, the relay monitor, and the restart connection. This module is located in slot 1 of the SafeBox and only exists once.

The OSSDs are designed as potential-free NO contacts. The module can be operated with or without startup / restart lock. Monitoring of the externally connected switching elements can be activated (relay monitor). The OSSD On or Off statuses are indicated via a short-circuit-proof PnP message output. The restart output is used to signal the start readiness status. In case of fault, this output oscillates at 1 Hz.

#### 7.1.2 Connections

The connections are designed as removable screw terminals or spring-loaded terminals. See Table 7.1 for the terminal assignment.

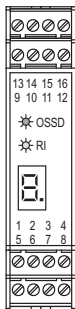

Terminal	Function
1	Reset input; normally closed contact
2	Restart input (RI); normally closed contact
3	24 V DC connection for reset, restart, and RM
4	Relay monitor (RM)
5–6	OSSD1; potential-free relay contact; NO contact
7–8	OSSD2; potential-free relay contact; NO contact
9	OSSD OFF message output
10	OSSD ON message output
11	Restart message output
12	Leave free (n.c.)
13	+24 V DC supply voltage
14	0 V DC supply voltage
15	Functional earth
16	Leave free (n.c.)

Table 7.1: Terminal assignment of OR / supply module

Figure 7.1: Front view of the OR module

### 7.1.3 Connection Assignment

#### OSSD Outputs

The OSSD outputs must be connected with the downstream safety devices such that the required safety category is met.



The load circuit of the external switching elements must be protected by a fuse with a maximum rated value of 60 % of the load capacity of the contacts to prevent the contacts from welding together. Ensure that inductive loads are provided with protective circuits against high induction voltages to protect the contacts of the OSSD outputs.

### Message Outputs

The message outputs are p-switching, short-circuit-proof semiconductor outputs. You can directly control lamps, relays, and PLC inputs.

Output	Terminal	Meaning
OSSD OFF	9	OSSD outputs switched off
OSSD ON	10	OSSD outputs switched on
Ready to start	11	Continuous light: protection field free, OSSD off, ready to start, actuate restart button
		Flashing (1 Hz): error on the card, in the switch group, or system error

Table 7.2: Message outputs

### Reset, Restart, and Relay-Monitor Inputs

The inputs must be wired with normally closed contacts. If a function is not required, the respective input may also be open.

#### 7.1.4 Settings

The assembly contains four DIP switches for selecting the restart and relay-monitor functions. Two switches must always be activated to select a function.

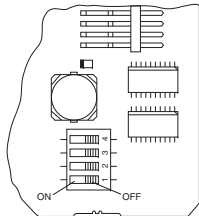

Switch	Position	Operating mode
1 and 3	OFF	Without startup / restart lock (restart, RI)
	ON	With startup / restart lock (restart, RI)
2 and 4	OFF	Without relay monitor (RM)
	ON	With relay monitor (RM)

Table 7.3: DIP switches

Figure 7.2: DIP-switch position

Figure 7.3: Connection example for OR / supply module

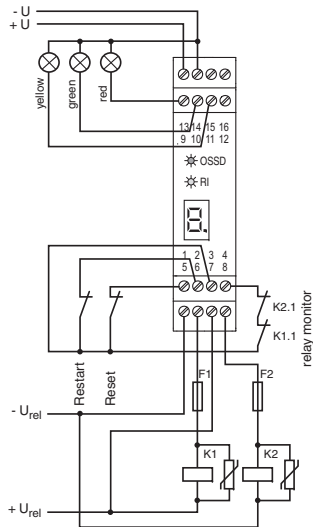

### 7.1.5 Indicators

The OR module has a red/green LED for signaling the OSSD on/off statuses, a yellow LED for the "ready for startup" status, and a 7-segment display for diagnostics.

The 7-segment display uses error codes to signal the status of the system. When an error occurs, the yellow LED of the first Supply / OSSD card flashes and the LEDs on the faulty module flash at 5 Hz.

Section 12 describes the troubleshooting options.

Figure 7.4 shows examples of errors:

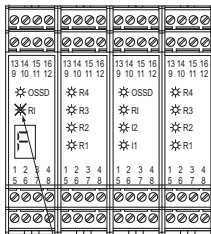

Error in relay monitor on OR module (slot 1)

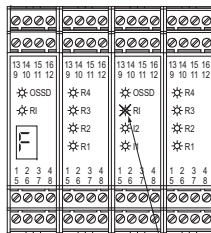

Error in relay monitor on 2E module (slot 3)

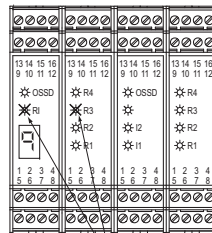









Error in sensor channel 3 on sensor module (slot 2)

Figure 7.4: Examples of error signaling

Indicator	LED	Meaning
OSSD	Red	OSSD outputs switched off
	Green	OSSD outputs switched on
RI	Yellow	Continuous light: protection field free, OSSD OFF, ready to start, actuate restart button
		Flashing (5 Hz): error on the card or system error (see status of 7-segment display)

Table 7.4: LED indicators

Indicator	7-segment display	Indicator	7-segment display
	DIP switch position not identical		Error in sensor channel
	Incorrect configuration		Error in sensor inputs
	Timeout of one or more muting sensors		System error
	Transmitter error		Relay-monitor error









	Muting-lamp error		Selection-chain error
	Simultaneity-monitoring error		Software unsuitable for configuration
	Receiver error		Low voltage or surge voltage detected

Table 7.5: 7-segment display

## 7.2 SB4 Function Module 2E

### 7.2.1 Function

The 2E module contains two OSSDs, the relay monitor, and two connections for contact-type safety signals (e.g., emergency switching off button). This module may exist several times (max. four times) from position 3 in the Safe-Box and perform different functions depending on the switch position.

The OSSDs are designed as potential-free NO contacts. The module can be operated with or without startup / restart lock. Monitoring of the externally connected switching elements can be activated (relay monitor). The OSSD On or Off statuses are indicated via a short-circuit-proof PnP message output. The restart output is used to signal the start readiness status. In case of fault, this output oscillates at 1 Hz.

The module can operate in the category 0 or category 1 stop function.

### 7.2.2 Connections

The connections are designed as removable screw terminals or spring-loaded terminals. See Table 7.6 for the terminal assignment.

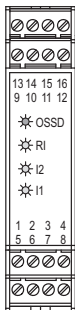

Terminal	Function	Terminal	Function
1	Safety element 1.1 Out	10	OSSD ON message output
2	Safety element 1.1 In	11	NC
3	Safety element 1.2 Out	12	Relay monitor (RM)
4	Safety element 1.2 In	13	+24 V DC supply voltage for message outputs
5-6	OSSD1; potential-free relay contact; NO contact	14	+0 V DC supply voltage for message outputs
7-8	OSSD2; potential-free relay contact; NO contact	15	24 V DC connection RM
9	OSSD OFF message output	16	NC

Table 7.6: Terminal assignment of the 2E module

Figure 7.5: Front view of the 2E module

### 7.2.3 Connection Assignment

#### OSSD Outputs

The OSSD outputs must be connected with the downstream safety devices such that the required safety category is met.



The load circuit of the external switching elements must be protected by a fuse with a maximum rated value of 60 % of the load capacity of the contacts to prevent the contacts from welding together. Ensure that inductive loads are provided with protective circuits against high induction voltages to protect the contacts of the OSSD outputs.

### Message Outputs

The message outputs are p-switching, short-circuit-proof semiconductor outputs. You can directly control lamps, relays, and PLC inputs.

Output	Terminal	Meaning
OSSD OFF	9	OSSD outputs switched off
OSSD ON	10	OSSD outputs switched on

Table 7.7: Message outputs

### Relay-Monitor Input

The input must be wired with NC contacts. If the function is not required, the input may also be open.

### Sensor Inputs

The inputs must be wired with NC contacts, e.g., a 2-channel emergency switching off button. Outputs Out 1 and 2 generate signals that are directed to inputs IN1 and IN2. Internal monitoring protects the inputs are cross bridging and short circuits. Insert a jumper if you would like the inputs to remain unused; this also applies to the set Stop 1- function.

Only 2-channel safety devices can be connected to the inputs, which are monitored for simultaneity.

Figure 7.6: Connection example of a 2E module with Stop 0- function

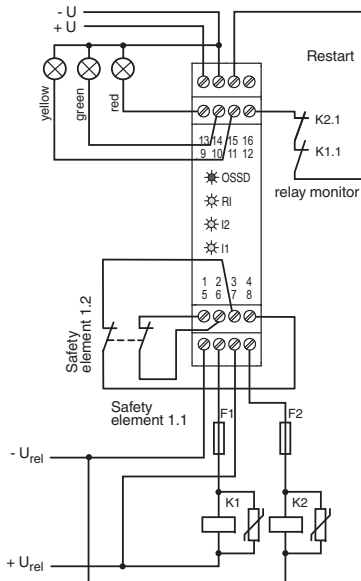

## 7.2.4 Settings

The assembly contains 16 DIP switches for selecting the functions for restarting, the relay monitor, OSSD assignment, and the time function. Two switches must always be activated to select a function.

The 2E module can be used for two different functions:

1. Position within a SafeBox, this acts as a Stop 1 module, whereby the function switch pairs 1, 2, and 3 of both groups must be set to OFF and switch 4 to ON; otherwise, error L is displayed.
2. The 2E module at the last position in the system is effective locally or centrally as an emergency switching off device.

Locally effective means that the stop function only affects the relevant stop card.

Centrally effective means that the stop function affects all stop cards.

Switch	Position	Operating mode: card position not as last card	Operating mode: card position as last card
<b>Switch group function</b>			
1 Groups 1 and 2	OFF	Not effective	If stop function cat. 0: effective locally If stop function cat. 1: no function
	ON	Not effective	If stop function cat. 0: effective centrally If stop function cat. 1: no function
2 Groups 1 and 2	OFF	Not effective	Without startup / restart lock (restart, RI)
	ON	Not effective	If stop function cat. 0: with startup / restart lock (restart, RI) If stop function cat. 1: no function
3 Groups 1 and 2	OFF	Without relay monitor (RM)	Without relay monitor (RM)
	ON	With relay monitor (RM)	With relay monitor (RM)
4 Groups 1 and 2	OFF	Error L	Stop function cat. 0
	ON	Stop function cat. 1 effective centrally	Stop function cat. 1

Table 7.3: DIP switches, function selection

Time value [s]	Switch group time function			
	Switch 1 Groups 1 and 2	Switch 2 Groups 1 and 2	Switch 3 Groups 1 and 2	Switch 4 Groups 1 and 2
0.0	OFF	OFF	OFF	OFF
0.3	ON	OFF	OFF	OFF
0.4	OFF	ON	OFF	OFF
0.5	ON	ON	OFF	OFF
0.63	OFF	OFF	ON	OFF
0.8	ON	OFF	ON	OFF
1.0	OFF	ON	ON	OFF
1.3	ON	ON	ON	OFF
1.6	OFF	OFF	OFF	ON
2.0	ON	OFF	OFF	ON
2.5	OFF	ON	OFF	ON
3.2	ON	ON	OFF	ON
4.0	OFF	OFF	ON	ON
5.0	ON	OFF	ON	ON
6.3	OFF	ON	ON	ON
8.0	ON	ON	ON	ON

Table 7.4: DIP switches, time setting

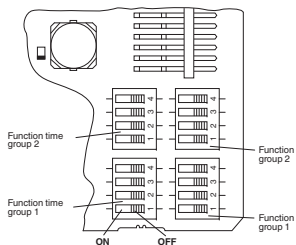

Figure 7.7: DIP-switch position

### 7.2.5 Indicators

The OSSD assembly has a red/green LED for signaling the OSSD on/off statuses, a yellow LED for the "ready to start" status, and two LEDs for the sensor channels.

If there is an error on the OSSD assembly itself, only the indicators on this assembly will flash.

Indicator	LED	Meaning
OSSD	Red	OSSD outputs switched off
	Green	OSSD outputs switched on
RI	Yellow	Continuous light: protection field free, OSSD off
		Flashing (5 Hz): error on the card or system error
I1, I2	Yellow	Continuous light: sensor channel closed
		Flashing (5 Hz): sensor-channel error

Table 7.5: 2E module indicators

## 7.3 Muting Module 4M

### 7.3.1 Function

The muting module provides the muting function for the sensor channels of the 4-channel or 6-channel sensor module immediately to the left of the module.

The user must make sure that only mutable sensors are connected to the sensor card to which the muting module is assigned. These include light barriers and light grids.

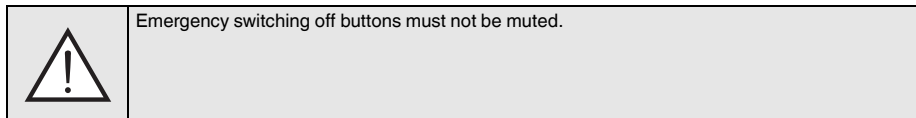

For a detailed description of the muting operating modes, see section 6.4.



### 7.3.2 Muting Sensors

Muting sensors are intended to detect the muting objects. If an object is detected, the output of the muting sensor switches through its supply voltage. Sensors with a relay output or a PnP output are suitable for this purpose. In a de-energized state, the output of the muting sensor must not be active. The sensor output should be able to reliably switch a load current of 8 mA at 20 V. Muting sensors with a current consumption of up to 30 mA can be supplied directly from the muting module. Sensors with a higher current consumption have to be supplied externally.

Muting sensors must be selected so that they operate even at a supply voltage of at least 12 V.

The cables to the muting sensors must be laid such that no short circuits are possible between the muting sensors.

Suitable sensors to use as muting sensors include:

- Dark-on or light-on retroreflective sensors (with reflector on object),
- Light sensors (light-on),
- Inductive sensors,
- Mechanical switches.

### 7.3.3 Muting Lamps

When using muting, an indicator lamp must be used for signaling the muting status. As an option, the muting module monitors the current of the muting indicator lamp for a minimum value of 7.5 mA. This monitoring ensures that the muting indicator lamp fulfills its warning function correctly. If the muting indicator lamp is faulty, the corresponding OSSD assembly goes into interlock mode and indicates error **6** (muting lamp faulty) on the display. While muting is active, the muting lamp can be controlled (muting lamp monitoring activated).

A maximum of two muting lamps can be connected to the muting module. In the case of double muting, a muting lamp is assigned to each pair of muting sensors or a half of the protection beams of a sensor module (see section 7.3.5).

If single muting has been selected, both muting lamp outputs are active simultaneously. This makes it possible to increase the availability of the plant, because a defective muting lamp will not cause a malfunction.

#### 7.3.4 Emergency Muting (Override)

If the plant must be started up again to remove the blocking object from the protection field and muting-sensor area, the emergency muting function is available. With emergency muting, the blocked muting sensors are re-analyzed for four seconds. As a result, the OSSDs are switched on again for four seconds. The emergency muting is triggered with the override switch (NC contact). To do this, at least one muting sensor must be enabled. This initialization can be retriggered, i.e., by actuating the push button again within four seconds, the duration of the on status of the OSSDs can always be extended until the object has left the muting-sensor area.

### 7.3.5 Double Muting

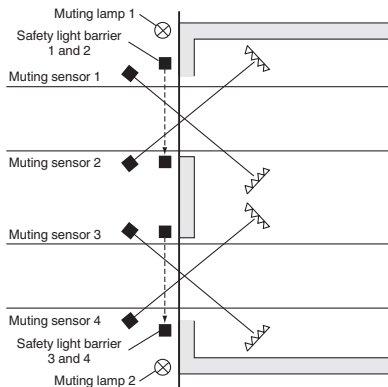

If the double muting operating mode is selected, two entries to a hazardous area can be protected and muted using a muting module and a sensor module.

This operating mode divides the sensor inputs of the sensor module to the left of the muting module, the muting-sensor inputs, the muting lamps, and the override inputs into two separate areas (see Table 7.11).

The two muting areas work completely independently from each other. Figure 7.8 shows a possible arrangement and Figure 7.9 shows the basic connection of the sensors and the lamps to the modules.

With double muting, all other adjustable operating modes (e.g., protection-beam limit or time limit) are effective for both muting areas.

Figure 7.8: Double muting, example configuration

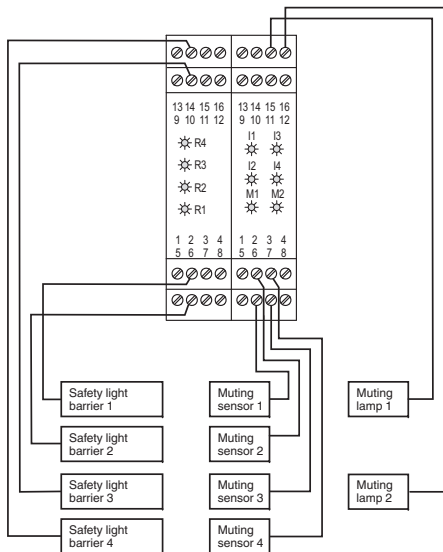

Figure 7.9: Double muting, schematic connection assignment of the modules

	Sensor input (light barrier) 4-channel sensor module	Sensor input (light barrier) 6-channel sensor module	Muting-sensor input	Muting-lamp output	Override input
Muting area 1	1 and 2	1, 2, 3	1 and 2	1	1
Muting area 2	3 and 4	4, 5, 6	3 and 4	2	2

Table 7.6: Sensor assignment, double muting

### 7.3.6 Connections

The connections are designed as removable screw terminals or spring-loaded terminals. See Table 7.12 for the terminal assignment.

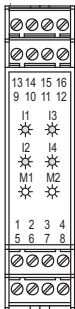

Terminal	Function	Terminal	Function
1	24 V sensor supply	9	Input override 1
2	Sensor 2 In	10	24 V override 1
3	Sensor 4 In	11	24 V Override 2
4	0 V sensor supply	12	Input Override 2
5	24 V sensor supply	13	+24 V DC supply voltage for muting lamps
6	Sensor 1 In	14	+0 V DC supply voltage for muting lamps
7	Sensor 3 In	15	Muting lamp output 1
8	0 V sensor supply	16	Muting lamp output2

Table 7.7: Terminal assignment of the muting module

Figure 7.10: Front view of the muting module

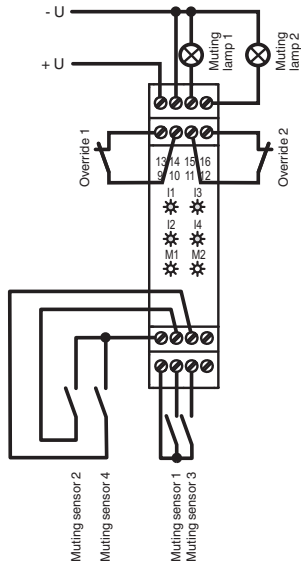

Figure 7.11: Connection assignment of the muting module

### 7.3.7 Settings

The assembly contains eight DIP switches for selecting the different muting operating modes. Two switches must always be activated to select a function.

Switch	Position	Operating mode
1 Groups 1 and 2	OFF	Muting-lamp monitoring inactive
	ON	Muting-lamp monitoring active
2 Groups 1 and 2	OFF	Single muting
	ON	Double muting
3 Groups 1 and 2	OFF	Time-frame-limited muting
	ON	Protection-beam-limited muting
4 Groups 1 and 2	OFF	Sequential muting
	ON	Parallel muting

Table 7.8: DIP switches, function selection



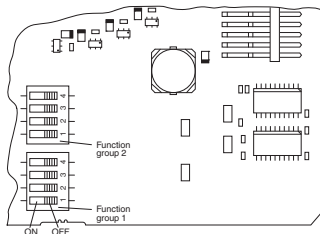

Figure 7.12: DIP-switch position

### 7.3.8 Indicators

The muting module has a yellow indicator for each muting sensor. For each muting lamp there is a white indicator. If there is an error in the muting module, only the yellow indicators on this assembly will flash.

In the case of an error on the muting lamps, the white muting indicators will flash.

Indicator	LED	Meaning
I1 ... I4	Yellow	Continuous light: muting sensor activated
		Flashing (5 Hz): muting-sensor error
M1, M2	White	Continuous light: muting activated
		Flashing (5 Hz): muting-lamp error

Table 7.9: Muting-module indicators

## 7.4 4-Channel or 6-Channel Sensor Modules (\*C\*)

### 7.4.1 Function

The 4-channel or 6-channel sensor module enables the connection of 2-wire light barriers or 2-wire light grids, or contact-type safety sensors in a 1-channel or 2-channel design. To connect SLP safety light grids or 2-channel p-switching safety devices, use a module with the letter X instead of C in the module name (see chapter 7.5).

The 4-channel sensor module is also available with MC control. This version only exists once in a system and is always located in slot 2 of the SafeBox.

When the system is switched on, the software determines whether a light barrier or a contact-type safety sensor is switched on in a channel and monitors its presence during operation. Contact-type safety sensors that are connected to the SafeBox must operate according to the normally closed principle. An open contact means "safe state."

Channels 1 and 2 as well as 3 and 4 (and 5 and 6) can be monitored for simultaneity or for exclusive OR function. If simultaneity monitoring is activated, 2-channel safety devices are monitored for simultaneous opening or changing of the signals. The monitoring time is two seconds.

Exclusive OR function monitoring expects the normally closed contact in channel 1 or 3 (or 5) and the normally open contact in channel 2 or 4 (or 6). If exclusive OR function monitoring is performed without simultaneity monitoring, an incorrect contact position causes a shutdown and error message 7 after approx. 60 seconds.

### 7.4.2 Connections

The connections are designed as removable screw terminals or spring terminals. See Table 7.15 or Table 7.16 for the terminal assignment.

Up to four light barriers can be connected to the 4-channel sensor module. Unused channels must be deactivated using a jumper between the transmitter output and the receiver input.

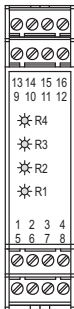

Terminal	Function	Channel assignment	Terminal	Function	Channel assignment
1	Receiver 2 input	Input Channel 2	9	Transmitter 3 output	Output Channel 3
2	Receiver 2 +U		10	Transmitter 3 +U	
3	Transmitter 2 +U		11	Receiver 3 +U	
4	Transmitter 2 output	Output	12	Receiver 3 input	Input
5	Receiver 1 input	Input Channel 1	13	Transmitter 4 output	Output Channel 4
6	Receiver 1 +U		14	Transmitter 4 +U	
7	Transmitter 1 +U		15	Receiver 4 +U	
8	Transmitter 1 output		Output	16	

Table 7.10: Sensor module (4C) connections

Figure 7.13: Sensor module (4C) connections

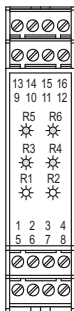

Terminal	Function	Terminal	Function
1	Transmitter 1 output	9	Receiver 1 input
2	Transmitter 2 output	10	Receiver 2 input
3	Transmitter 3 output	11	Receiver 3 input
4	Transmitter 1 ... 3 +U	12	Receiver 1 ... 3 +U
5	Transmitter 4 output	13	Receiver 4 input
6	Transmitter 5 output	14	Receiver 5 input
7	Transmitter 6 output	15	Receiver 6 input
8	Transmitter 4 ... 6 +U	16	Receiver 4 ... 6 +U

Table 7.11: 6-channel sensor-module connections

Figure 7.14: 6-channel sensor-module connections

### 7.4.3 Connection Assignment

#### 7.4.3.1 Connection of Light Barriers or Light Grids

The light-barrier transmitters and light-barrier receivers are connected to the sensor module according to the core color or pin number.

The length of the connecting cables between the evaluation device and the transmitter or receiver must not exceed 100 m. The connecting cable is specified in section 13.

Light-grid transmitters and light-grid receivers are connected such that they are assigned to a sensor module. If this is not possible, it must be ensured that the +U connections of the light grids are equally distributed. Unused channels must be bridged according to Table 7.18.

Light barrier			Evaluation device SB4
	Pin	Core color	Sensor-module terminal
Transmitter	3	Blue (BU)	Transmitter x output
	4	Black (BK)	Transmitter x +U
Receiver	1	Brown (BN)	Receiver x +U
	3	Blue (BU)	Receiver x input

Table 7.12: Light-barrier terminal assignment  
Sensor-module evaluation device

Light barrier to be replaced	Jumper	
	4-channel sensor module	6-channel sensor module
1	1–4	1–9
2	5–8	2–10
3	9–12	3–11
4	13–16	5–13
5		6–14
6		7–15

Table 7.13: Unused sensor channels

Figure 7.15: Connection example of a 4-channel sensor module

Figure 7.15 shows a connection example for two light barriers (channel 3 and 4), one jumper (channel 1), and a 1-channel safety switch on channel 2.

LSS = light-barrier transmitter, LSE = light-barrier receiver

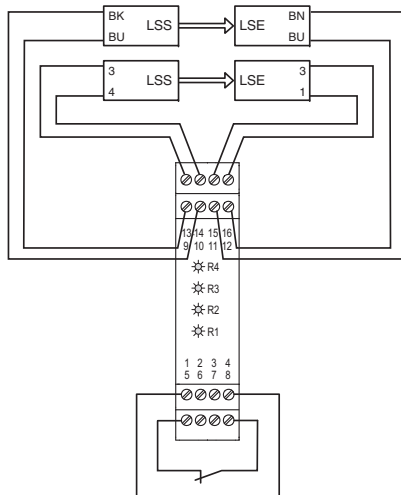

### 7.4.3.2 Connection of Sensors with Simultaneity or Exclusive OR Function Monitoring

Contact-type safety devices can also be connected to sensor modules. If 2-channel signals are used, use simultaneity monitoring to detect errors in one of the channels.

Together, contact-type safety devices and light barriers can be connected to one sensor module. In this case, simultaneity monitoring and exclusive OR function monitoring is not effective for the light barriers. Channels 1 and 2 or 3 and 4 (or 5 and 6 for 6-channel sensor module) must be used for the contact-type signals.

LSS = light-barrier transmitter  
LSE = light-barrier receiver

Figure 7.16: Connection of two light barriers and a 2-channel safety device to a 4-channel sensor module

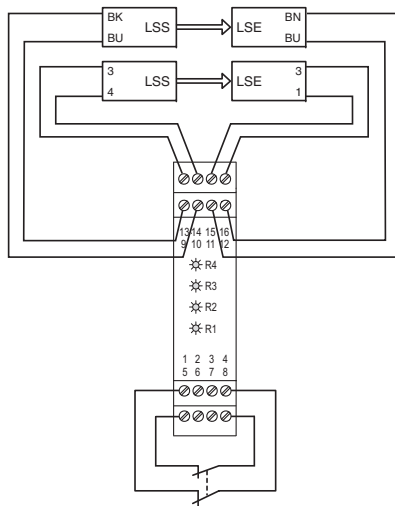

### 7.4.4 Settings

The assembly contains four DIP switches for selecting the simultaneity functions of neighboring channels (1 and 2, 3 and 4), and for a complementary evaluation of neighboring channels (1 and 2, 3 and 4 or also 5 and 6). Two switches must always be activated to select a function. The functions are not effective if light barriers are connected.

Switch	Position	Operating mode
1 and 3	OFF	No complementary evaluation
	ON	Complementary evaluation active
2 and 4	OFF	No simultaneity evaluation
	ON	Simultaneity evaluation active

Table 7.14: Sensor-module DIP switch

Figure 7.17: Connection of two 2-channel, complementary safety devices to a 4-channel sensor module

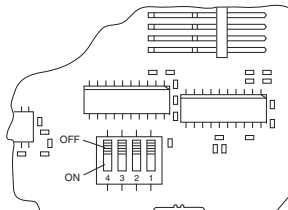
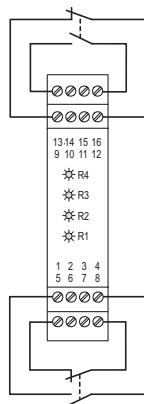

Figure 7.18: Position of the sensor-module DIP switch

#### 7.4.4.1 Indicators

For each channel, there is a yellow LED on the front panel of the module.

Indicator	LED	Meaning
R1 ... R4 (R1 ... R6)	Yellow	Status of light barrier 1 ... 4 (6)
		Off: light beam interrupted
		On: light beam unobstructed
		Flashing: light beam free, insufficient operating reserve (frequency approx. 2.5 Hz)
		Flashing quickly: error (frequency approx. 5 Hz)

Table 7.15: Sensor-module LEDs, four or six channels

## 7.5 4-Channel Sensor Module (4X\*)

### 7.5.1 Function

The 4-channel sensor module -4X\* enables the connection of SLA series "3-wire" light barriers (such as SLA5) and SLP light grids. P-switching safety devices with dedicated cross-bridging monitoring can also be connected, such as SLC series safety light curtains. Switching mats designed according to the 4-wire principle and 1-channel or 2-channel contact-type safety sensors can also be connected.

This module is also available with MC control. This version only exists once in a system and is always located in slot 2 of the SafeBox.

The assembly features a 6x DIP switch used to select the sensors to be connected. Select two switches in pairs. The safety sensors are connected on channels 1 and 2 or 3 and 4.

You can connect SLA and SLP "3-wire" light barriers and light grids to channels 1 to 4.





The cables must be selected and routed to the light barriers and light grids in such a way as to ensure short circuits cannot occur between the receiver wire and the transmitter wire.

Light curtains with semiconductor switching outputs and 2-channel contact-type safety sensors are monitored for simultaneity. With simultaneity monitoring, the safety devices are monitored for simultaneous opening or changing of the signals. The monitoring time is two seconds.

Connect via channels 3 and 4 and/or 1 and 2.



Remember that these sensors require their own cross-bridging monitoring, because the module does not do this with these sensors.

Make sure that self-monitoring safety devices with semi-conducting outputs Q1 and Q2 follow this testing pulse pattern:

Testing pulse length  $T_I$  should not exceed 300  $\mu\text{s}$  and the refresh rate  $T_W$  should not be less than 500  $\mu\text{s}$ .

SB4: number of modules	Refresh rate of test pulse
2	10 ms
3	14 ms
4	18 ms
5	22 ms
6	26 ms
8	34 ms

Table 7.16: Interval between test pulses based on module quantity

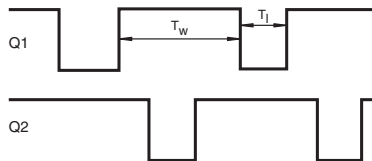

Figure 7.19: Time diagram for test pulses

If the test-pulse length is greater than 300  $\mu\text{s}$ , the refresh rate in relation to the number of cards of the SB4 switching device should not be below the value shown in Table 7.21; otherwise, error messages may appear.

Switching mats designed in accordance with the 4-wire principle can be connected to channels 1 and 2 and/or 3 and 4. If the switching mat has a faulty connection, the system reports error 9 or error 8 as it does when detecting a 2-channel contact-type safety sensor.

## 7.5.2 Connections

The connections are designed as removable screw terminals or spring terminals. See Table 7.22 for the terminal assignment.

You can connect up to four light barriers or two 2-channel p-switching safety devices or two switching mats to the 4-channel sensor module. Unused channels must be deactivated using a jumper between the transmitter output and the receiver input.

Figure 7.20: Front view and terminal assignment of the 4X(P) module

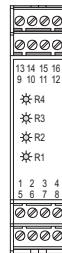

Terminal	Function	Channel assignment	Light-barrier / light-grid connection	2-channel p-switching safety-device connection	Switching-mat connection	
1	Receiver 2 input	Channel 2	Input	Receiver output 2	OSSD output 1.2	Switching mat 1.4
2	Sensor 2 24 V DC +U			24 V receiver 2	24 V Supply 1	
3	Sensor 2 GND ground			0 V receiver 2, transmitter 2	0 V Supply 1	
4	Transmitter 2 output		Output	Transmitter input 2		Switching mat 1.3
5	Receiver 1 input	Channel 1	Input	Receiver output 1	OSSD output 1.1	Switching mat 1.2
6	Sensor 1 24V DC +U			24 V receiver 1		
7	Sensor 1 GND ground			0 V receiver 1, transmitter 1		
8	Transmitter 1 output		Output	Transmitter input 1		Switching mat 1.1
9	Transmitter 3 output	Channel 3	Input	Transmitter input 3		Switching mat 2.4
10	Sensor 3 GND ground			0 V receiver 3, transmitter 3	0 V Supply 2	
11	Sensor 3 24V DC +U			24 V receiver 3	24 V Supply 2	
12	Receiver 3 input		Output	Receiver output 3	OSSD output 2.2	Switching mat 2.3
13	Transmitter 4 output		Input	Transmitter input 4		Switching mat 2.2
14	Sensor 4 GND ground	Channel 4		0 V receiver 4, transmitter 4		
15	Sensor 4 24V DC +U				24 V receiver 4	
16	Receiver 4 input		Output	Receiver output 4	OSSD output 2.1	Switching mat 2.1

Table 7.17: Terminal assignment of the 4X(P) module and assignment to various sensors

### 7.5.3 Connection Assignment

#### 7.5.3.1 Connecting Light Barriers and Light Grids

You can connect SLA5(S) or SLA40 light barriers and SLP light grids to these modules.

The light-barrier transmitters and light-barrier receivers are connected to the sensor module according to the core color or pin number.

The length of the connecting cables between the evaluation device and the transmitter or receiver must not exceed 100 m.



The cables must be arranged and routed to the light barriers and light grids in such a way as to ensure short circuits cannot occur between the receiver wire and the transmitter wire. The connecting cable is specified in section 13.

Light-grid transmitters and light-grid receivers are connected such that they are assigned to a sensor module. If this is not possible, it must be ensured that the +U connections of the light grids are equally distributed. Unused channels must be bridged according to Table 7.24.

Figure 7.16 shows a connection example for two light barriers (channels 3 and 4) and a 2-channel safety switch on channels 1 and 2.

Light barrier		Evaluation device SB4
Pin	Core color	Sensor-module terminal
3	Blue (BU)	Transmitter GND ground
4	Black (BK)	Transmitter x output
1	Brown (BN)	Receiver 24 V 24 V DC +U
3	Blue (BU)	Receiver GND ground
4	Black (BK)	Receiver x input

Table 7.18: Terminal assignment of the light barrier or light grid for the sensor-module evaluation device

Light barrier to be replaced	Jumper
	4-channel sensor module
1	1–4
2	5–8
3	9–12
4	13–16

Table 7.19: Jumpers for unused sensor channels

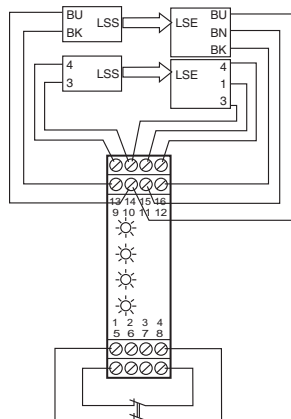

Figure 7.21: Connection example of a 4-channel sensor module 4X

### 7.5.3.2 Connecting Switching Mats and 2-Channel p-Switching Safety Devices

The following illustrations show connection examples for the combined use of safety light curtains and a switching mat on a 4X module.

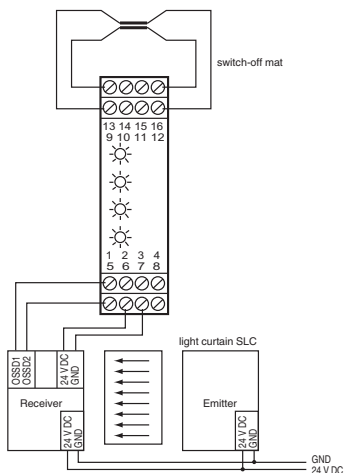

Figure 7.22: Connecting an SLC safety light curtain and a switching mat to a 4X module

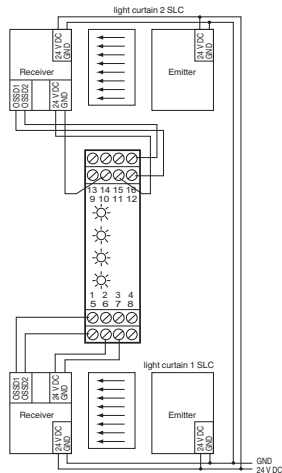

Figure 7.23: Connecting two safety light curtains to a 4X module

#### 7.5.4 Settings

Six DIP switches for selecting the sensor type and position are available on the assembly. There are six ways in which to combine the sensors. The required combination must be set in binary form. To select the function, two switches must always be actuated, i.e., DIP switches 1 ... 3 have the same switch position as DIP switches 4 ... 6.

DIP switches			Operating mode
3 and 6	2 and 5	1 and 4	
0	0	0	SLA/SLP/jumper on channel 1 + 2 and channel 3 + 4
0	0	1	SLA/SLP/jumper on channel 1 + 2 and SLC channel 3 + 4
0	1	0	SLC on channel 1 + 2 and channel 3 + 4
0	1	1	SLA/SLP/jumper on channel 1 + 2 and pressure-sensitive mat on channel 3 + 4
1	0	0	Pressure-sensitive mat on channel 1 + 2 and channel 3 + 4
1	0	1	SLC on channel 1 + 2 and pressure-sensitive mat on channel 3 + 4

Table 7.20: DIP switches for sensor module 4X(P)



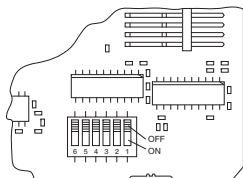

Figure 7.24: Position of the sensor module 4X(P) DIP switches

#### 7.5.4.1 Indicators

For each channel, there is a yellow LED on the front panel of the module to indicate the status of the input channel.

Indicator	LED	Meaning
R1–R4 (R1–R6)	Yellow	Status of sensor inputs 1 ... 4
		Off: interrupted On: free
		Flashing: light beam free, insufficient operating reserve (frequency approx. 2.5 Hz)
		Flashing quickly: error (frequency approx. 5 Hz)

Table 7.21: Indication LEDs on the 4 X(P) module

## 7.6 Basic Housing and Accessories

An SB4 evaluation device can also be composed of individual components. For this purpose, additional components are available in addition to the modules already described. These are:

- SB4 Housing 2 ... 8 (basic housing with 2 ... 8 slots for holding individual modules)
- SB4 Cape (blind cap for covering a slot of the basic housing).



The minimum configuration of a SafeBox consists of a basic housing and one assembly each for slots 1 and 2.

## 7.7 Mounting Notes for Modules and Basic Housings

Modules may only be operated within an SB4 evaluation device.

Mounting or exchanging modules of a SafeBox may be necessary if you would like to modify or extend the function of an evaluation device. In this case, remember that the type code is no longer correct and the response time must be corrected depending on the number of modules.



A changed response time must in any case be considered regarding the safety calculations.

A plugin jumper must be inserted into the two-pin pin strip on the last module in each case (furthest to the right). Either the module that is currently located on the last slot can be moved further to the right or the plugin jumper must be reconnected to the new module.

If an evaluation device is assembled from individual modules by the user, it must be ensured that:

- The desired safety function can be fulfilled by the selected modules and their connection sequence
- There is an OR module in slot 1
- There is a module with MC control in slot 2, e.g., 4CP or 4XP

- There is a module in each slot and that there are no gaps
- The plugin jumper is connected to the last module (to the right)
- Blind caps cover the slots that are not used
- An ESD-compliant workspace is used for mounting
- The response time according to the configuration is marked on the device.

For the smallest extension level, a basic housing, a module for slot 1, and a module for slot 2 are required. The module for slot 2 (SB4 Module 4CP or 4XP) is supplied with a plugin jumper. If additional modules are used, this plugin jumper must be moved.

## 8 Setup and Mounting of the Light Barriers and Light Grids

The safety light barriers and light grids should be arranged such that the transmitters that are connected to the sensor modules of an SB4 evaluation device cannot irradiate the receivers on other evaluation devices.

The mounting must be carried out such that it is not possible to enter the hazardous area by circumventing the protection beams.

It must not be possible:

- To crawl through under the lowest beam
- To reach over the highest beam or
- To pass between two beams



The calculation of the minimum distance of the light grids from the hazardous area can be found in the applicable guidelines and standards.

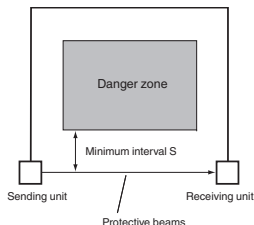

Figure 8.1: Minimum distance between electro-sensitive protective equipment and hazardous area

This distance is calculated from the lag time of the machine, the response time of the safety system, and the speed of movement of the person entering the hazardous area (EN ISO 13855).

To comply with the necessary distances in the event that the protection field spreads, please refer to Table 1 of EN ISO 13855 to check the minimum distance for a vertically located protection field. If you read the value 0 from the table, you can determine the minimum distance with the following formula:

EN ISO 13855 states:

$$S = K \times T + C$$

The following applies to a protection field installed perpendicular to the hazardous area:

S	Minimum safety distance in mm, i.e., the distance between the hazardous area and the protection field
K	Constant in mm/s for the speed of approach, based on the detection capacity of the sensor
T	Total response time of the protective equipment in s ( $T = t_1 + t_2$ )
$t_1$	Response time of the protective equipment E.g., SLA light barriers with SB4 40 ms (relay OSSD)

$t_2$	Machine lag time
C	Additional distance in mm, see table
	2-, 3-, or 4-beam
	850 mm

Table 8.1: For arrangements other than a perpendicular arrangement of the protection field, see also EN ISO 13855.

#### Layout of Individual Beams

Number of beams	Height above the floor [mm]	Beam spacing [mm]
2	400, 900	500
3	300, 700, 1100	400
4	300, 600, 900, 1200	300

The layout of the beams must prevent a person from being able to

- Crawl under the lowest beam,
- Climb over the highest beam, or
- Climb between the two beams.



**Note!**

If an applicable C standard recommends positioning the first beam 400 mm above the floor, follow this recommendation.  
If no recommendation was given, use a risk analysis to determine whether the arrangement is permissible.



It must be ensured that reflective objects that may cause a light beam reflection around an obstacle are not located within the transmitting or receiving lobe (EN 61496-2).

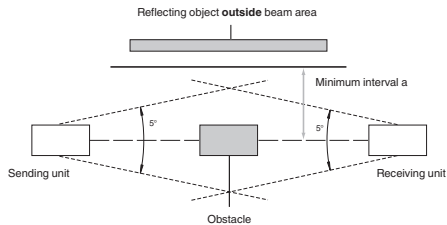

Figure 8.2: Reflection

## 9 Installation

When integrating the evaluation device and the safety light grids into the safety-related control system of the machine, the instructions in EN 61496-1 must be considered, among other things (connecting the control elements downstream of the electro-sensitive protective equipment).

**Note!**

The relevant laws and standards that apply to the use of photoelectric protective equipment must be followed. There are differences depending on the area of use.

The following general points should be observed during installation:

- Have the applicable standards and regulations been observed?
- Does the technical data of the electro-sensitive protective equipment meet the requirements of the application?
- Have the necessary distances been observed?
- Are all inputs and outputs wired correctly?
- Do the non-floating inputs and outputs of the evaluation device have double or reinforced insulation to protect them against external circuits with dangerous voltages?
- Is the evaluation device installed in a closed and locked housing or case (at least IP54 in accordance with EN 61496-1) to prevent unauthorized modification of the connections or configuration and to ensure protection against direct or indirect contact (in accordance with EN 60204-1:2007 or IEC 60204-1:2009)?
- For sensors susceptible to short circuits, have the cables been routed in such a way as to make short circuits between inputs and outputs impossible?
- Is it impossible to circumvent the protective equipment?
- Is the restart button located so that all the hazardous area can be viewed?
- Is it impossible to press the restart button from inside the hazardous area?
- Are the muting sensors arranged correctly?
- Is the muting indicator lamp in a clearly visible position?

- Is the emergency muting button located so that all the hazardous area can be viewed?
- Is it impossible to press the emergency muting button from inside the hazardous area?
- Has the response time been marked according to the number of existing modules on the nameplate (left side of the device)? (Only applies if the user personally removes or adds modules)

## 10 Commissioning

### 10.1 Adjusting Protection Beams

The transmitters and receivers must be aligned with each other such that they are standing in front of each other at the same height and that the lowest beam is at the correct height above the floor.

A reflector can facilitate adjustment of the transmitters. The reflector is fitted in front of the lens of the receiver. The system is switched on and a bearing takes place from the transmitter in the direction of the reflector. The transmitter must be adjusted such that the red transmitter light can be seen in the reflector. The transmitter must be fixed in position. The receiver is now pivoted such that the function indicator shows a continuous light.

### 10.2 Function Test

#### 10.2.1 Testing the Detection Capacity of the Installed Electro-Sensitive Protective Equipment

The following tasks must be carried out to check the detection capacity:

- Remove all objects from the beam pathways
- Disconnect all light beams one by one while checking that the corresponding channel display goes dark
- Check whether interrupting the light beam causes the intended reaction in the downstream safety device

#### 10.2.2 Checking the Sensors and Stop Functions

- Checking the sensor inputs (based on the LEDs per input)
- Checking stop function cat. 1

#### 10.2.3 Checking Other Connected Safety Devices

- Check whether the safety devices have been connected according to the applicable guidelines and notes



#### 10.2.4 Checking the Muting Function

- Checking the installation position of the muting sensors
- Checking the correct connection of the muting lamp
- Checking the selected muting operating mode and the muting process

### 11 Periodic Inspection

A daily inspection of the entire safety equipment is required if the OSSD outputs are relays and if it is not guaranteed that:

- The protection field is interrupted at least once a day
- Or the device is not switched on at least once per day of operation

The inspection is carried out as follows:

- Release the protection field and, if necessary, enable restart
- Interrupt any beam

Check whether the interruption of the light beam causes the intended reaction in the downstream safety device

If the evaluation device does not assume a fault state, the inspection is complete.

Further inspections of the connected safety elements, such as protective-door contacts, must be carried out according to the required inspection cycles.



During the periodic inspection of the safety function of the plant in which the SB4 evaluation system is fitted, the functions of the electro-sensitive protective equipment must also be checked. Among other things, the proper arrangement, the proper installation, and the required response time must be checked. Inspection records of the performed inspections must be maintained and kept.

## 12 Fault Repair

Errors in the system always cause the affected switch group to assume the safe interlock mode. There are errors that only affect the switch group and errors that affect the entire system. In the latter case, all OSSDs are switched off.

The 7-segment display indicates the detected error. The channel display of the faulty channel will flash on the faulty module concerned. If the error affects the entire module, all channel displays will flash. This way, the error can be easily detected and eliminated.







To acknowledge an error, the operator presses the reset input for 0.4 ... 1.2 s to perform a reset. After a successful system test, the SB4 assumes the operating state or stops in the fault state with the respective fault indication.

Certain errors can only be eliminated by switching off the supply voltage and switching it on again because the system must determine the new configuration.



If, after elimination of an error, the operating voltage is reconnected, the user must check the correct configuration of the system. To do this, enable every sensor once (e.g., with light barriers and light grids by interrupting every beam) and check how the evaluation device responds or what the sensor display does.

The following table lists possible self-help measures:

Indicator	Error	Remedy
All indicators of the SB4 are dark	Voltage supply is faulty	Check the voltage supply
LEDs of the channels do not light up	Protection beam interrupted or safety device triggered	Clear the protection beams. Check whether all transmitters are functioning. Remove dirt. If necessary, readjust the transmitters and receivers. Activate the safety device.
	DIP switch position not identical	Check and correct the switch position
	Incorrect configuration	The set configuration is faulty. Check and correct the configuration.
	Timeout of one or more muting sensors	The fault indicator disappears when errors are eliminated (e.g., after the end of muting in the case of protection-beam-limited muting). Check the muting sensors. If necessary, clear the area of material using override.
	Transmitter error	Check the installation of the affected transmitter
	Muting-lamp error	Check the muting lamp or the installation
	Error in simultaneity monitoring	May occur in the case of muting sensors or sensors with activated simultaneity monitoring. In the case of sensors, the error must be confirmed. In the case of muting sensors, the error is confirmed by deactivating the muting sensors.
	Receiver error	Check the installation of the affected receiver







	Error in sensor channel	Check the installation of the affected channel
	Error in sensor channel	Check the installation, because there may be a short circuit on the sensor inputs for the supply voltage
	System error	Delete the error via a reset or by switching off the voltage. If the error persists, contact customer service or send device for repair
	Relay-monitor error	Check the wiring of the OSSDs and the external relays
	Selection-chain error	Check whether the plugin jumper is located in the last slot (several plugin jumpers may be set)
	Configuration error	Change the configuration
	Low voltage/surge voltage detected	Check the supply voltage. Reset the error by switching off the voltage.

Table 12.1: Fault repair

## 13 Technical Data

### 13.1 Functional Safety Data

Safety integrity level	SIL 3 (IEC 61508)
PFHd	SB4-OR...: 3.47 E-09 (IEC 61508)  The specified PFHd value applies to all versions and up to the maximum ambient temperature
Performance level	PL e (as per ISO 13849-1)
Category	4 (as per ISO 13849-1)
Type	4 (as per EN 61496-1)
Useful lifetime	20 a
B10D value (Relay OSSD version) DC-13, 24 V I = 2 A I ≤ 1 A	100,000 switching cycles 1,300,000 switching cycles For additional values see OSSD outputs

### 13.2 Conformity with Standards And Directives

Directive conformity	See declaration of conformity (enclosed or available at <a href="http://www.pepperl-fuchs.com">www.pepperl-fuchs.com</a> )
Standard conformity	
Functional safety	IEC 61508 part 1-4
Standards	IEC 61496-1

### 13.3 Approvals and Certificates

CE conformity	CE
UKCA conformity	UKCA
UL approval	cULus Listed UL File Number E215245
TÜV approval	TÜV

### 13.4 Parameters

Number of protection beams	Maximum 32
Dimensions (H x W x D)	SB4-OR-4CP: 99 mm x 45.2 mm x 114.5 mm SB4-OR-4CP-4C and SB4-OR-4CP-4M: 99 mm x 67.8 mm x 114.5 mm General: 99 mm x (22.6 x number of slots) mm x 114.5 mm
Supply voltage	24 V DC $\pm$ 20 % Supply from safe extra-low voltage (e.g., PELV IEC 60204)
Protection class	Without marking, mounting in suitable switch cabinet required, protection class III for connected accessories  <p><b>Danger:</b> Danger to life due to electric shock!              Insufficient separation distances can negate the safe separation of a SELV / PELV supply of the auxiliary circuits of the protective equipment. This can lead to a life-threateningly high voltage on the device or connected system accessories. Protection class III of the auxiliary circuits and the necessary safe separation distance must be taken into account when designing the insulation coordination of the electrical installation or machine. For more information, see IEC 60204, IEC 60664, IEC 61140, and the relevant national regulations.</p>
Current consumption	Max. 2 A <sup>1)</sup>
Power consumption	50 W

Safety output of OSSD

Normally open contacts, force-guided  
Limiting current min. 10 mA, max. 6 A  
Switching voltage min. 10 V AC/DC, max. 250 V AC/DC  
Switching characteristics: 24 VA DC, 230 VA AC  
External fuse with  $< 0.6 \times$  limit load current, quick-acting  
Switching frequency: max. 1/s



**Attention:** Relay output must be protected by a fuse against welding.  
The externally connected switching elements should be operated with a maximum of 60 % of their rated load capacity to avoid overload.

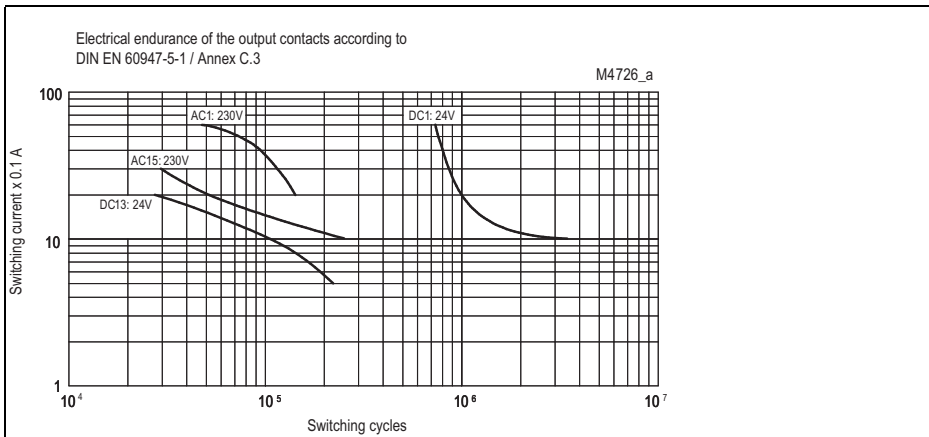



Reaction times	Response time: SB4-OR-4CP, SB4-OR-4XP: 30 ms SB4-OR-4CP-4C, SB4-OR-4CP-4M, SB4-OR-4XP-4X, and SB4-OR-4XP-4M: 38 ms								
	General:	Number of assemblies	2	3	4	5	6	7	8
		Shutdown time [ms] Relay OSSD	30	38	46	54	62	70	78
	Reactivation time after sensor channels have been released: SB4-OR-4CP, SB4-OR-4XP: 108 ms SB4-OR-4CP-4C, SB4-OR-4CP-4M, SB4-OR-4XP-4X, and SB4-OR-4XP-4M: 156 ms								
	General:	Number of assemblies	2	3	4	5	6	7	8
		Reactivation time [ms] Relay OSSD	108	156	204	252	300	348	396
Muting activation after activation of the muting sensors: SB4-OR-4CP-4M, SB4-OR-4XP-4M: 91 ms									
General:	Number of assemblies	3	4	5	6	7	8		
	Activation time for muting [ms] Relay OSSD	91	119	147	175	203	230		
PNP outputs	Output voltage: supply voltage—2 V, output current: max. 300 mA								
Muting-lamp outputs	Output voltage: supply voltage—2 V (when using LED lamps, the minimum voltage for sufficient brightness must be taken into account) Output current: 7.5–500 mA								
Indicators	OSSD status: red/green LED Fault status: 7-segment display Restart: yellow LED Sensor status: one yellow LED per input Muting status: white LED								
Inputs (switch connections, relay monitor)	Input resistance approx. 2.2 kOhm Voltage: operating voltage—1 V Current: approx. 10 mA								

Activation time for button connections (Reset, Restart, Override)	0.4 s–1.2 s
Sensor Inputs (4C, 6C, 4X module)	Voltage: operating voltage—1 V Current: approx. 7 mA
Sensor supply (4X module)	Voltage: operating voltage—1 V Current: max. 20 mA, short-circuit proof
Muting-sensor inputs	Input resistance approx. 2.2 kOhm Voltage: operating voltage—1 V Current: approx. 10 mA
Connection	Removable screw terminal blocks or spring-loaded terminal blocks, conductor cross section 0.2 mm <sup>2</sup> ... 2 mm <sup>2</sup>
Cable lengths	Max: 100 m at max. line resistance of 3 ohms
Degree of protection	IP 20; IP54 must be guaranteed for operation by using an installation housing
Housing	Polyamide PA 6.6, UL94, V0, black
Operating temperature/storage temperature	0 °C ... +50 °C / -25 °C ... +85 °C
Air humidity	Max. 95 %, not condensing
Shock resistance	Switching devices: stationary switch cabinet mounting without relevant mechanical loads Connected sensors: see the respective datasheet
Vibration resistance	Switching devices: stationary switch cabinet mounting without relevant mechanical loads Connected sensors: see the respective datasheet
Ground	SB4-OR-4CP: 320 g SB4-OR-4CP-4C and SB4-OR-4CP-4M: 430 g General: 35 g + 150 g x number of slots

<sup>1)</sup> Evaluation device without connected external consumers, e.g., lamps and relays

### 13.5 Dimensions

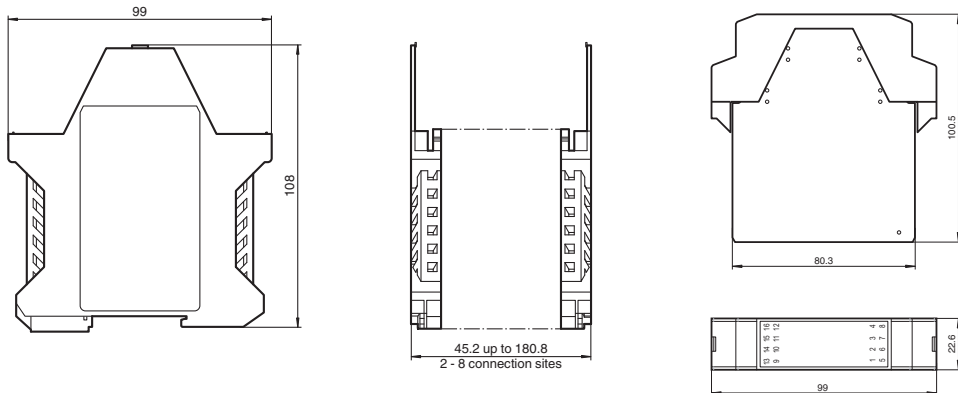

Figure 13.1: Dimensions of SB4 housing and SB4 module

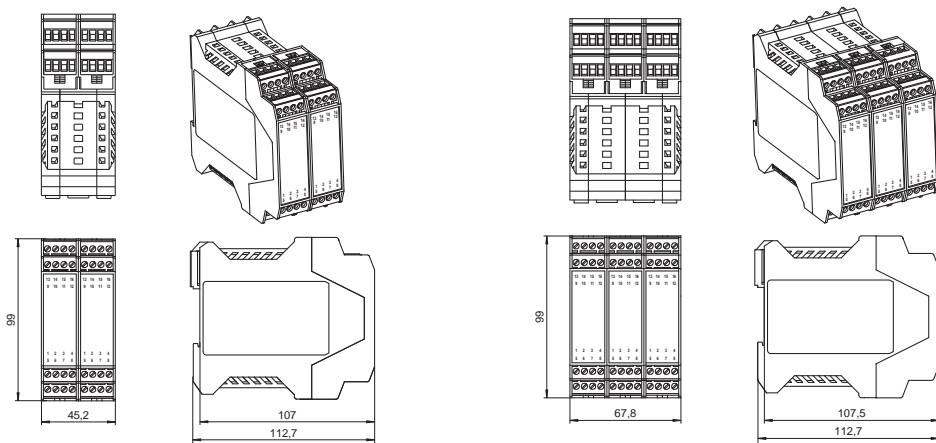

Figure 13.2: Dimensions of SB4-OR-4CP and SB4-OR-4CP-4C (SB4-OR-4CP-4M)

## 14 Application Checklist

A list of important points should help you avoid errors when planning, setting up, and operating the protective equipment. This application checklist is not complete and must be modified to suit each specific application.



**Note: Observe the relevant laws and standards!**

The relevant laws and standards that apply to the use of photoelectric protective equipment must be followed. There are differences depending on the area of use.

### 14.1 Before Installation

- Have all the applicable standards and regulations been observed?
- Does the technical data of the SB4-... meet the requirements of the application? (E.g., number of channels, module types, operating voltage)?
- Is the overvoltage category required by EN 50178 or EN 60947-1 met at the connections?
- Are the electrical equipment, the wiring, and the overcurrent protection designed in accordance with IEC 60204-1:2009?
- Is there enough space for mounting and dismantling the components?
- On the connected safety light barriers and light grids, have the given distances between the protection field and the hazardous area and reflected surfaces been observed?

### 14.2 After Installation

- Is the startup enable input connected when the startup / restart lock is activated?
- Is the ready-to-start signal lamp connected?
- Is the red/green indicator for signaling the status of the OSSD outputs in a visible location?
- Are all components correctly connected?
- Are the connected safety light barriers or light grids positioned so that the protection field cannot be bypassed and people cannot enter the hazardous area undetected?

- Are the connected safety light barriers and light grids aligned?
- Have the necessary safety distances been maintained?
- Are there fuses in the OSSD current circuits that are intended to prevent the contacts from welding together?

#### 14.3 Commissioning

- Did you check the detection capacity of the connected safety light barriers or light grids with the test rod? This test should take place at multiple locations and at least once in front of the transmitter unit and the receiver unit, and in the middle of the protection field.
- Do the OSSD switching outputs trigger the requisite stop?
- Has the reaction time been checked?

#### 14.4 Periodic Inspection

- Have the requisite test steps and test intervals been determined?
- Are the protection beams interrupted at least four times on each day of operation or is the plant switched on to test the shutdown function of the safety system?
- Is the detection capacity of the connected safety light barriers or light grids checked regularly?
- Are the response times checked at regular intervals?
- Is all machine safety equipment inspected at the required intervals?
- Are all inspections documented?

## 15 Ordering Information

### 15.1 Devices

Designation	Description
SB4-OR-4CP	Evaluation device with four safety inputs for connecting 2-wire SLA12 or SLA29 safety light barriers or with IF-SB4 SLCS or SLCT safety light grids
SB4-OR-4CP-4M	Evaluation device with four safety inputs and four muting inputs for connecting 2-wire SLA12 or SLA29 safety light barriers or with IF-SB4 SLCS or SLCT safety light grids
SB4-OR-4CP-4C	Evaluation device with eight safety inputs for connecting 2-wire SLA12 or SLA29 safety light barriers or with IF-SB4 SLCS or SLCT safety light grids
SB4-OR-4XP	Evaluation device with four safety inputs for connecting SLP safety light grids, SLCS / SLCT safety light curtains, or 3-wire light barriers (e.g., SLA5 or SLA40)
SB4-OR-4XP-4M	Evaluation device with four safety inputs for connecting SLP safety light grids, SLCS / SLCT safety light curtains, or 3-wire light barriers (e.g., SLA5 or SLA40) and four muting inputs
SB4-OR-4XP-4C	Evaluation device with eight safety inputs for connecting 2-wire light barriers (SLA12/SLA29), 3-wire light barriers (SLA5/SLA40), SLP safety light grids, or SLCS or SLCT safety light curtains.

## 15.2 Modules

Model name	Description
SB4 Module OR	SB4 basic module with two safety switching outputs and diagnostics
SB4 Module 4CP	SB4 sensor module with processing unit for four sensors, such as Pepperl+Fuchs 2-wire SLA12 and SLA29 safety light barriers, sensors with NC contacts (with IF-SB4, also SLCS and SLCT safety light grids)
SB4 Module 4C	Same as SB4 Module 4CP, but without processing unit
SB4 Module 6C	Same as SB4 Module 4C, but connectivity for six sensors
SB4 Module 4XP	SB4 sensor module with processing unit for four sensors, such as Pepperl+Fuchs 3-wire SLA5 and SLA40 safety light barriers, sensors with PNP semiconductor outputs such as SLCS and SLCT
SB4 Module 4X	Same as SB4 Module 4XP, but without processing unit
SB4 Module 4M	SB4 muting module for two, four, or 2x2 muting sensors. Supports parallel, sequential, double muting, protection-beam-limiting muting, override
SB4 Module 2E	SB4 function module with the functions STOP 0, STOP 1.
SB4 Housing 2	Module rack with backplane and two slots
SB4 Housing 3	Module rack with backplane and three slots
SB4 Housing 4	Module rack with backplane and four slots
SB4 Housing 5	Module rack with backplane and five slots
SB4 Housing 6	Module rack with backplane and six slots
SB4 Housing 8	Module rack with backplane and eight slots
SB4 Cape	Cap for unused slots



## 16 Glossary

Startup / restart lock	Device that prevents the OSSDs from switching on after the protection field has been cleared.
ESPE	<b>E</b> lectro- <b>s</b> ensitive <b>p</b> rotective <b>e</b> quipment
EDM	<b>E</b> xternal <b>d</b> evice <b>m</b> onitoring, NC contact of the downstream safety components that reports switching of the dangerous action to the SafeBox, also referred to as relay monitor
Operating reserve	Distance of the receiver signal of the light barrier from the lower limit of the switching point of the light barrier
Muting	Intended bypassing of protection beams
Emergency muting	Switching on the OSSDs with invalid muting condition (only possible under certain conditions and when monitored by operator)
OSSD	<b>O</b> utput <b>s</b> ignal <b>s</b> witching <b>d</b> evice of the safety loop of the electro-sensitive protective equipment, as per EN IEC 61496-1
Override	See emergency muting
Reset	Resetting a confirmable error
Restart	Releasing the restart of the electro-sensitive protective equipment from the status of the startup / restart lock
RM	Abbreviation for <b>r</b> elay <b>m</b> onitor, see also EDM
RI	Abbreviation for <b>r</b> estart <b>i</b> nterlock, see also Restart



The latest version of the General Terms of Delivery for Products and Services in the Electronics Industry set out by the German Electrical and Electronic Manufacturers' Association (ZVEI) and the "Extended Reservation of Proprietorship" supplementary clause apply.

# FACTORY AUTOMATION – SENSING YOUR NEEDS



## Worldwide Headquarters

Pepperl+Fuchs Group · Mannheim · Germany  
E-mail: [info@de.pepperl-fuchs.com](mailto:info@de.pepperl-fuchs.com)

## USA Headquarters

Pepperl+Fuchs Inc. · Twinsburg · USA  
E-mail: [sales@us.pepperl-fuchs.com](mailto:sales@us.pepperl-fuchs.com)

## Asia Pacific Headquarters

Pepperl+Fuchs Pte. Ltd · Singapore  
E-mail: [sales@sg.pepperl-fuchs.com](mailto:sales@sg.pepperl-fuchs.com)

[www.pepperl-fuchs.com](http://www.pepperl-fuchs.com)

Subject to reasonable modifications due to technical advances • Copyright Pepperl+Fuchs • Printed in Germany



 **PEPPERL+FUCHS**  
SENSING YOUR NEEDS

DOCT-0783J

Part no. 70184980  
08.2024