

Ultrasonic Level Sensor LUC-M** with HART/4 mA ... 20 mA

Operating instructions

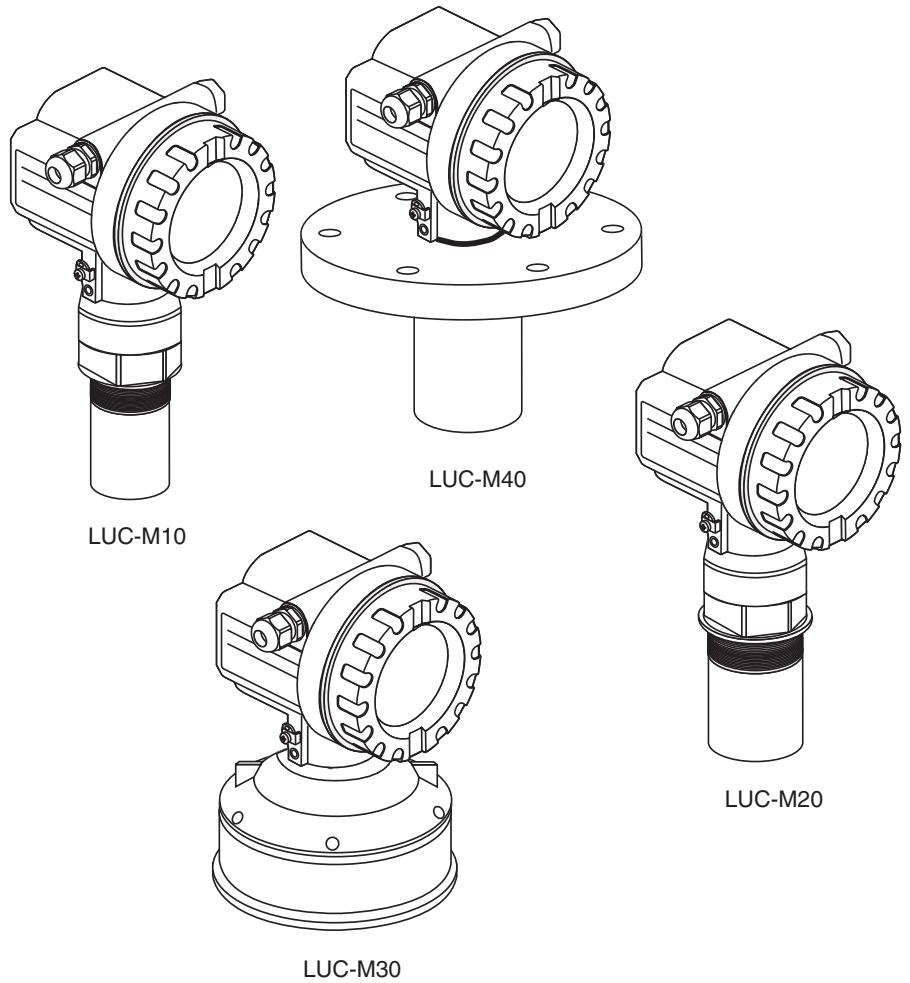

Valid as of software version
V 01.04.00 (amplifier)
V 01.04.00 (communication)

KA 1830/98/a2/04.05
52027994
185587 04/05 00

LUC-M - Quick setup**

PEPPERL+FUCHS

⚠ Contrast: E + + or E + -

000 measured value

group selection

00 basic setup

002 tank shape

003 medium property

004 process cond.

005 empty calibr.

006 full calibr.

008 dist./meas. value

051 check distance

052 range of mapping

053 start mapping

01 safety settings

03 temperature

04 linearisation

05 extended calibr.

06 output (HART, FF) profibus param. (PA)

0E envelope curve

09 display

0A diagnostics

0C system parameter

0E1 plot settings

0E2 recording curve

092 language

0A0 present error

0A1 previous error

0A3 reset

0A4 unlock parameter

0C0 tag no.

25dB 090
-0.01 2.461m 5.00

333 (HART)
33333 (PA)

100 (HART)
2457 (PA)

BD: blocking distance

52027994

This operating instructions describes the installation and commissioning of the LUC-M** ultrasonic level transmitter. It contains all the functions required for a normal measuring operation.

Also, the LUC-M** provides additional functions for optimising the measuring point and for converting the measured value. These functions are not included in this operating instructions.

You can find an **overview of all the device functions** in the appendix.

You can find a **detailed description of all the device functions** in the operating instructions BA 2400 "Description of instrument functions".

Additional information (certificates and data sheets for LUC-M**) is provided on our website www.pepperl-fuchs.com (Search for LUC-M* in the product search).

Short instructions	2	7 Troubleshooting	40
1 Safety instructions	4	7.1 System error messages	40
1.1 Designated use	4	7.2 Application errors	42
1.2 Installation, commissioning, operation	4	8 Maintenance and repairs	43
1.3 Operational safety	4	8.1 Exterior cleaning	43
1.4 Notes on safety conventions and symbols	5	8.2 Repairs	43
2 Identification	6	8.3 Repairs to Ex-approved devices	43
2.1 Device designation	6	8.4 Replacement	43
2.2 Scope of delivery	9	8.5 Spare parts (housing type F12)	44
2.3 Certificates and approvals	9	8.6 Spare parts (housing type T12)	46
2.4 Registered trademarks	9	8.7 Return	48
3 Installation	10	8.8 Disposal	48
3.1 Dimensions	10	8.9 Software history	48
3.2 Installation variants	12	8.10 Contact addresses of Pepperl+Fuchs	48
3.3 Installation conditions	14	9 Accessories	49
3.4 Measuring range	17	9.1 Weather protection cover	49
3.5 Installation hint for LUC-M10/20	18	9.2 Mounting bracket for LUC-M10/LUC-M20	49
3.6 Turn housing	19	9.3 Mounting bracket for LUC-M30/LUC-M40	49
3.7 Installation check	19	9.4 Cantilever	50
4 Wiring	20	9.5 Operating and display module LUC-Z15	50
4.1 Electrical connection	20	9.6 Mounting frame for cantilever	51
4.2 Terminal assignment	21	9.7 Wall bracket for cantilever	51
4.3 Supply voltage	22	9.8 Adapter flange for LUC-M10/LUC-M20	52
4.4 Potential matching	23	9.9 Universal slip-on flange for LUC-M30	53
4.5 Checking the connection	23	9.10 Remote display and operation	53
5 Operation	24	10 Technical data	54
5.1 Display and operating elements	24	10.1 Input	54
5.2 Function codes	26	10.2 Output	54
5.3 Operating options	27	10.3 Auxiliary energy	54
5.4 Operation using the on-site display LUC-Z15	28	10.4 Performance characteristics	55
5.5 Operation using PACT^{ware} ™	29	10.5 Ambient conditions	56
5.6 Operation using the HART handheld terminal Field Communicator 375	29	10.6 Process conditions	57
5.7 Lock/unlock configuration	30	11 Appendix	58
5.8 Resetting the customer parameters	30	11.1 Operating menu	58
5.9 Resetting an interference echo suppression (tank map)	31	11.2 Measuring principle	60
6 Commissioning	32	Index	61
6.1 Power up instrument	32	Declaration of hazardous material and de-contamination	62
6.2 Basic calibration	33		
6.3 Envelope curve	37		

1 Safety instructions

1.1 Designated use

The LUC-M** is a compact measuring device for continuous, non-contact level measurement. Depending on the sensor, the measuring range is up to 15 m in fluids and up to 7 m in bulk solids. By using the linearisation function, the LUC-M** can also be used for flow measurements in open channels and measuring weirs.

1.2 Installation, commissioning, operation

The LUC-M** is fail-safe and is constructed to the state-of-the-art. It meets the appropriate standards and EC directives. However, if you use it improperly or other than for its designated use, it may pose application-specific hazards, e. g. product overflow due to incorrect installation or configuration. Installation, electrical connection, start-up, operation and maintenance of the measuring device must therefore be carried out exclusively by trained specialists authorised by the system operator. Technical personnel must have read and understood these operating instructions and must adhere to them. You may only undertake modifications or repair work to the device when it is expressly permitted by the operating instructions.

1.3 Operational safety













Hazardous area

Measuring systems for use in hazardous environments are accompanied by separate "Ex documentation", which is an integral part of this Operating Manual. Strict compliance with the installation instructions and ratings as stated in this supplementary documentation is mandatory.

- Ensure that all personnel are suitably qualified.
- Observe the specifications in the certificate as well as national and local regulations.

1.4 Notes on safety conventions and symbols

In order to highlight safety-relevant or alternative operating procedures in the manual, the following conventions have been used, each indicated by a corresponding symbol in the margin.

Safety conventions	
	Warning! A warning highlights actions or procedures which, if not performed correctly, will lead to personal injury, a safety hazard or destruction of the instrument.
	Caution! Caution highlights actions or procedures which, if not performed correctly, may lead to personal injury or incorrect functioning of the instrument.
	Note! A note highlights actions or procedures which, if not performed correctly, may indirectly affect operation or may lead to an instrument response which is not planned.
Explosion protection	
	Device certified for use in explosion hazardous area If the device has this symbol embossed on its name plate it can be installed in an explosion hazardous area.
	Explosion hazardous area Symbol used in drawings to indicate explosion hazardous areas. Devices located in and wiring entering areas with the designation "explosion hazardous areas" must conform with the stated type of protection.
	Safe area (non-explosion hazardous area) Symbol used in drawings to indicate, if necessary, non-explosion hazardous areas. Devices located in safe areas still require a certificate if their outputs run into explosion hazardous areas.
Electrical symbols	
	Direct voltage A terminal to which or from which a direct current or voltage may be applied or supplied.
	Alternating voltage A terminal to which or from which an alternating (sine-wave) current or voltage may be applied or supplied.
	Grounded terminal A grounded terminal, which as far as the operator is concerned, is already grounded by means of an earth grounding system.
	Protective grounding (earth) terminal A terminal which must be connected to earth ground prior to making any other connection to the equipment.
	Equipotential connection (earth bonding) A connection made to the plant grounding system which may be of type e. g. neutral star or equipotential line according to national or company practice.
	Temperature resistance of the connection cables States, that the connection cables must be resistant to a temperature of at least 85 °C (358 K).

2 Identification

2.1 Device designation

2.1.1 Nameplate



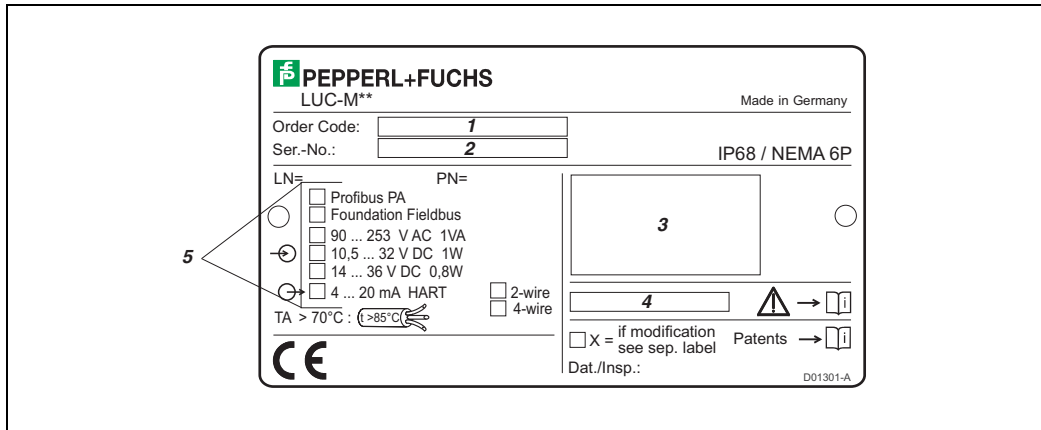

Informations at the LUC-M** nameplate (example)



- 1: Order code
- 2: Serial number
- 3: Designation according to Directive 94/9/EG and designation of protection (only for certified versions)
- 4: Reference to additional safety-relevant documentation (only for certified versions)
- 5: Communication variant and supply voltage (the appropriate option is highlighted)

2.1.2 Product structure LUC-M10





LUC-M10- - - - -

- Certificate**
- NA version for non-explosion hazardous areas
 - EX  II 1/2 G EEx ia IIC T6
 - ES  II 1/2 D, aluminium cover
 - E2  II 1/3 D
 - SX  II 1/2 G EEx d (ia) IIC T6
 - S2  II 3G EEx nA II T6
 - F1 FM IS, Cl. I/II/III, Div.1 Group A-G, N.I .Cl. I, Div.2
 - F2 FM XP, Cl. I/II/III, Div. 1, Group A-G
 - CG CSA, General Purpose
 - C1 CSA IS, Cl. I/II/III, Div. 1, Group A-D, G + coal dust, N.I.
 - C2 CSA XP, Cl. I/II/III, Div. 1, Group A-D, G + coal dust, N.I.
- Display**
- A * prepared for remote display, order display as accessory LUC-Z40
 - B without display
 - D with display LUC-Z15 inclusive on-site operation, envelope curve display
- Electrical output**
- AH 4-wire, 90 V AC ... 250 V AC, 4 mA ... 20 mA, HART
 - DH 4-wire, 10.5 V DC ... 32 V DC, 4 mA ... 20 mA, HART
 - PA 2-wire, PROFIBUS PA
 - IH 2-wire, 4 mA ... 20 mA, HART
- Cable entry**
- 2 cable gland M20 x 1.5
 - 3 thread G1½
 - 4 thread ½ NPT
 - 5 connector M12, PROFIBUS PA
- Housing**
- A1 aluminium housing F12, IP68, thread M20 x 1.5
 - A2 aluminium housing T12, IP68, coated, with separate terminal compartment
 - A4 aluminium housing T12, IP68, coated, with separate terminal compartment, overvoltage protection
- Process connection**
- G5 thread G1½B, ISO 228, PVDF
 - N5 thread 1½ NPT, ANSI, PVDF

* in preparation

2.1.3 Product structure LUC-M20

LUC-M20- - - - -

- Certificate**
- NA version for non-explosion hazardous areas
 - EX  II 1/2 G EEx ia IIC T6
 - ES  II 1/2 D, aluminium cover
 - E2  II 1/3 D
 - SX  II 1/2 G EEx d (ia) IIC T6
 - S2  II 3G EEx nA II T6
 - F1 FM IS, Cl. I/II/III, Div.1 Group A-G, N.I .Cl. I, Div.2
 - F2 FM XP, Cl. I/II/III, Div. 1, Group A-G
 - CG CSA, General Purpose
 - C1 CSA IS, Cl. I/II/III, Div. 1, Group A-D, G + coal dust, N.I.
 - C2 CSA XP, Cl. I/II/III, Div. 1, Group A-D, G + coal dust, N.I.
- Display**
- A * prepared for remote display, order display as accessory LUC-Z40
 - B without display
 - D with display LUC-Z15 inclusive on-site operation, envelope curve display
- Electrical output**
- AH 4-wire, 90 V AC ... 250 V AC, 4 mA ... 20 mA, HART
 - DH 4-wire, 10.5 V DC ... 32 V DC, 4 mA ... 20 mA, HART
 - PA 2-wire, PROFIBUS PA
 - IH 2-wire, 4 mA ... 20 mA, HART
- Cable entry**
- 2 cable gland M20 x 1,5
 - 3 thread G1½
 - 4 thread ½ NPT
 - 5 connector M12, PROFIBUS PA
- Housing**
- A1 aluminium housing F12, IP68, thread M20 x 1.5
 - A2 aluminium housing T12, IP68, coated, with separate terminal compartment
 - A4 aluminium housing T12, IP68, coated, with separate terminal compartment, overvoltage protection
- Process connection**
- G6 thread G2B, ISO 228, PVDF
 - N6 thread 2 NPT, ANSI, PVDF

* in preparation

2.1.4 Product structure LUC-M30

LUC - M30 - - - - -

- Certificate**
 - NA version for non-explosion hazardous areas
 - ES II 1/2 D, aluminium cover
 - E2 II 1/3 D
 - FM FM DIP, Cl. II, Div.1 Group E-G, N.I. Cl. I, Div.2
 - CG CSA, General Purpose
 - CS CSA DIP, Cl. II, Div. 1, Group E-G, N.I. Cl. I, Div.2
- Display**
 - A * prepared for remote display, order display as accessory LUC-Z40
 - B without display
 - D with display LUC-Z15 inclusive on-site operation, envelope curve display
- Electrical output**
 - AH 4-wire, 90 V AC ... 250 V AC, 4 mA ... 20 mA, HART
 - DH 4-wire, 10.5 V DC ... 32 V DC, 4 mA ... 20 mA, HART
 - PA 2-wire, PROFIBUS PA
- Cable entry**
 - 2 cable gland M20 x 1,5
 - 3 thread G1/2
 - 4 thread 1/2 NPT
 - 5 connector M12, PROFIBUS PA
- Housing**
 - A1 aluminium housing F12, IP68, thread M20 x 1.5
- Process connection**
 - FA universal flange DN100/ANSI 4"/JIS16K100, PP
 - FS universal flange DN100/ANSI 4"/JIS16K100, 316Ti
 - FK without slip-on flange, without mounting bracket, customer mounting equipment
 - FM with mounting bracket LUC-Z17

* in preparation

2.1.5 Product structure LUC-M40

LUC - M40 - - - - -

- Certificate**
 - NA version for non-explosion hazardous areas
 - EX II 1/2 G EEx ia IIC T6
 - SX II 1/2 G EEx d (ia) IIC T6
 - S2 II 3G EEx nA II T6
 - F1 FM IS, Cl. I/II/III, Div.1 Group A-G, N.I. Cl. I, Div.2
 - F2 FM XP, Cl. I/II/III, Div. 1, Group A-G
 - CG CSA, General Purpose
 - C1 CSA IS, Cl. I/II/III, Div. 1, Group A-D, G + coal dust, N.I.
 - C2 CSA XP, Cl. I/II/III, Div. 1, Group A-D, G + coal dust, N.I.
- Additional option**
 - A basic version
- Sealing sensor/flange**
 - 2 Viton
 - 3 EPDM
- Display**
 - A * prepared for remote display, order display as accessory LUC-Z40
 - B without display
 - D with display LUC-Z15 inclusive on-site operation, envelope curve display
- Electrical output**
 - AH 4-wire, 90 V AC ... 250 V AC, 4 mA ... 20 mA, HART
 - DH 4-wire, 10.5 V DC ... 32 V DC, 4 mA ... 20 mA, HART
 - PA 2-wire, PROFIBUS PA
 - IH 2-wire, 4 mA ... 20 mA, HART
- Cable entry**
 - 2 cable gland M20 x 1.5
 - 3 thread G1/2
 - 4 thread 1/2 NPT
 - 5 connector M12, PROFIBUS PA
- Housing**
 - A1 aluminium housing F12, IP68, thread M20 x 1.5
 - A2 aluminium housing T12, IP68, coated, with separate terminal compartment
 - A4 aluminium housing T12, IP68, coated, with separate terminal compartment, overvoltage protection
- Process connection; max. 3 bar abs/44 psia, hole circle PN16/150 lbs/10K**
 - P universal flange DN80/ANSI 3"/JIS10K80, PP
 - Q universal flange DN80/ANSI 3"/JIS10K80, PVDF
 - S universal flange DN80/ANSI 3"/JIS10K80, 316L
 - T universal flange DN100/ANSI 4"/JIS16K100, PP
 - U universal flange DN100/ANSI 4"/JIS16K100, PVDF
 - V universal flange DN100/ANSI 4"/JIS16K100, 316L
 - M mounting bracket LUC-Z17

* in preparation

2.2 Scope of delivery

2.2.1 Instrument and accessories

- Instrument according to the version ordered
- for LUC-M10/20 in the versions LUC-M10-G5**** and LUC-M20-G6****:
counter nut (PA)
- for LUC-M10/20: sealing ring (EPDM)
- for gland M20 x 1.5:
 - 1 cable gland for 2-wire instruments
 - 2 cable glands for 4-wire instrumentsThe cable glands are mounted on delivery.

2.2.2 Supplied documentation

Short instructions (KA1830, in the instrument)

intended as a memory jogger for users who are familiar with the operating concept of Pepperl+Fuchs time-of-flight instruments.

Operating instructions (BA2370, this booklet)

This describes the installation and commissioning of the LUC-M**. The operating menu includes all the functions which are required for standard measurement tasks. Any additional functions are **not** included.

Description of instrument functions (BA2400)

contains a detailed description of **all** the functions of the LUC-M**.

Safety instructions

Additional safety instructions (SI, ZE, ZD) are supplied with certified device versions. Refer to the nameplate for the names of the safety instructions that apply to your device variant.



Note!

Additional information (certificates and data sheets for LUC-M**) is provided on our website www.pepperl-fuchs.com (Search for LUC-M* in the product search). The software tool **PACTware™** and the appropriate DTM is provided on our website www.pepperl-fuchs.com (Search for Pactware in the product search).

2.3 Certificates and approvals

CE mark, declaration of conformity

The device is designed to meet state-of-the-art safety requirements, has been tested and left the factory in a condition in which it is safe to operate. The device complies with the applicable standards and regulations as listed in the EC declaration of conformity and thus complies with the statutory requirements of the EC directives. Pepperl+Fuchs confirms the successful testing of the instrument by affixing to it the CE mark.

2.4 Registered trademarks

HART®

Registered trademark of HART Communication Foundation, Austin, USA

3 Installation

3.1 Dimensions

3.1.1 Level sensors

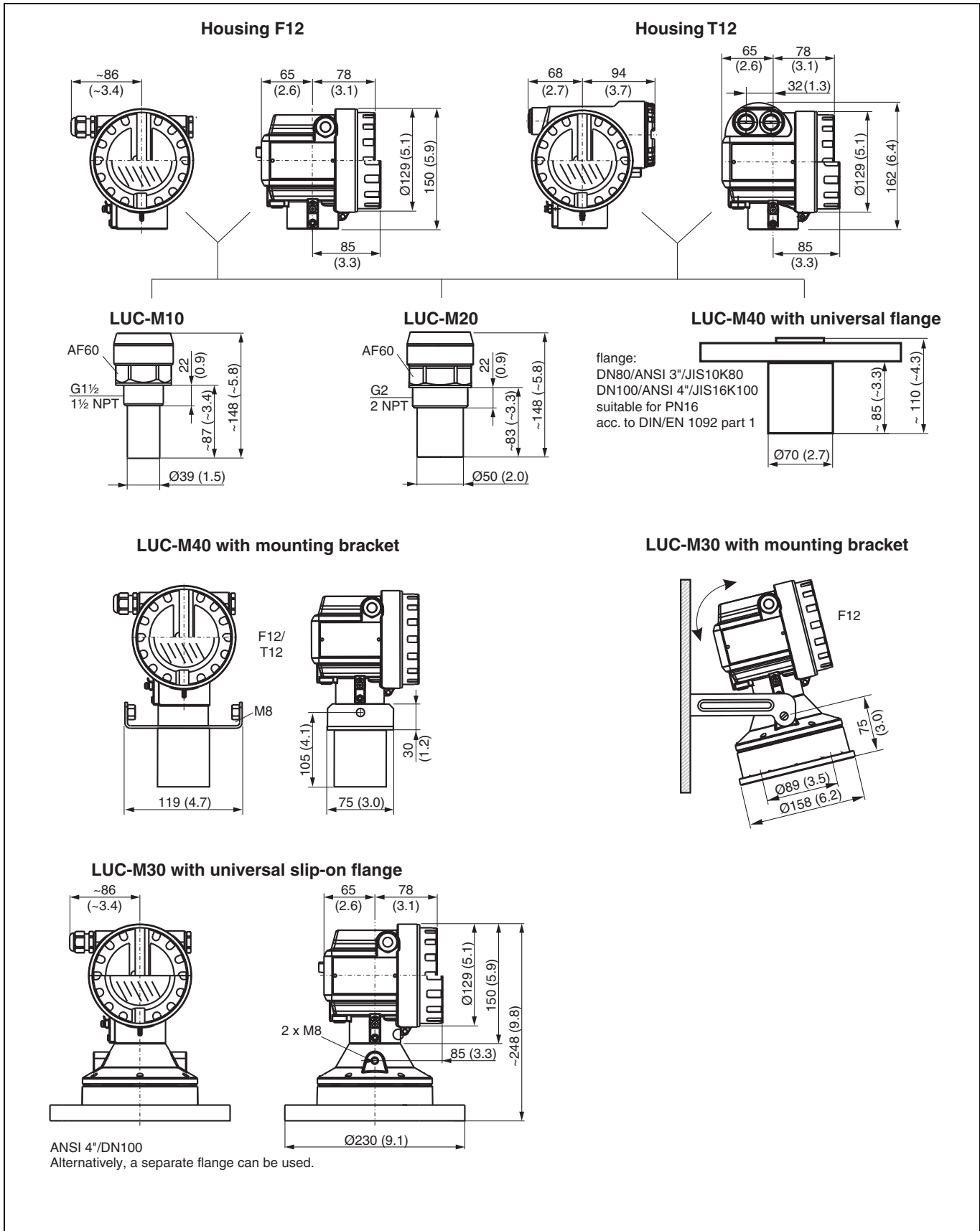

3.1.2 Mounting bracket for LUC-M30 and LUC-M40

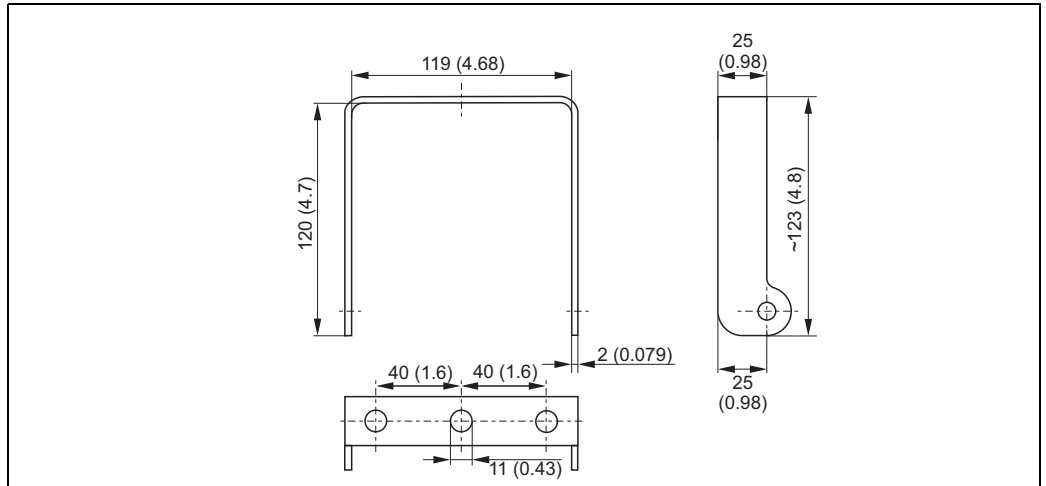

Dimensions in mm (inch)

3.1.3 Universal flanges for LUC-M40

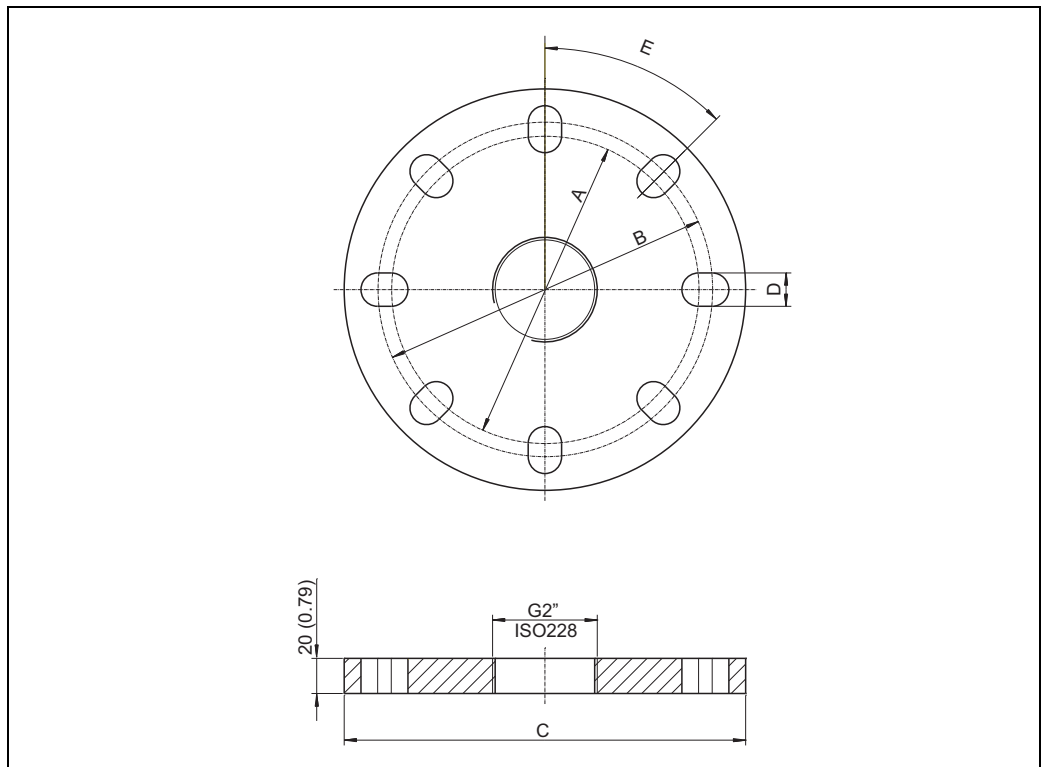

Dimensions in mm (inch)

suitable for	A	B	C	D	E	Number of boreholes
3" 150 lbs/DN80 PN16/10K 80	150 mm (5.91")	160 mm (6.30")	200 mm (7.87")	19 mm (0.75")	45°	8
4" 150 lbs/DN100 PN16/10K 100	175 mm (6.90")	190.5 mm (7.50")	228.6 mm (9.00")	19 mm (0.75")	45°	8
6" 150 lbs/DN150 PN16/10 K 150	240 mm (9.45")	241.3 mm (9.50")	285 mm (11.22")	23 mm (0.91")	45°	8
8" 150 lbs	298.5 mm (11.75")	298.5 mm (11.75")	342.9 mm (13.50")	22.5 mm (0.89")	45°	8
DN200 PN16/10 K 200	290 mm (11.42")	295 mm (11.61")	340 mm (13.39")	23 mm (0.91")	30°	12

3.2 Installation variants

3.2.1 Installation variants LUC-M10, LUC-M20

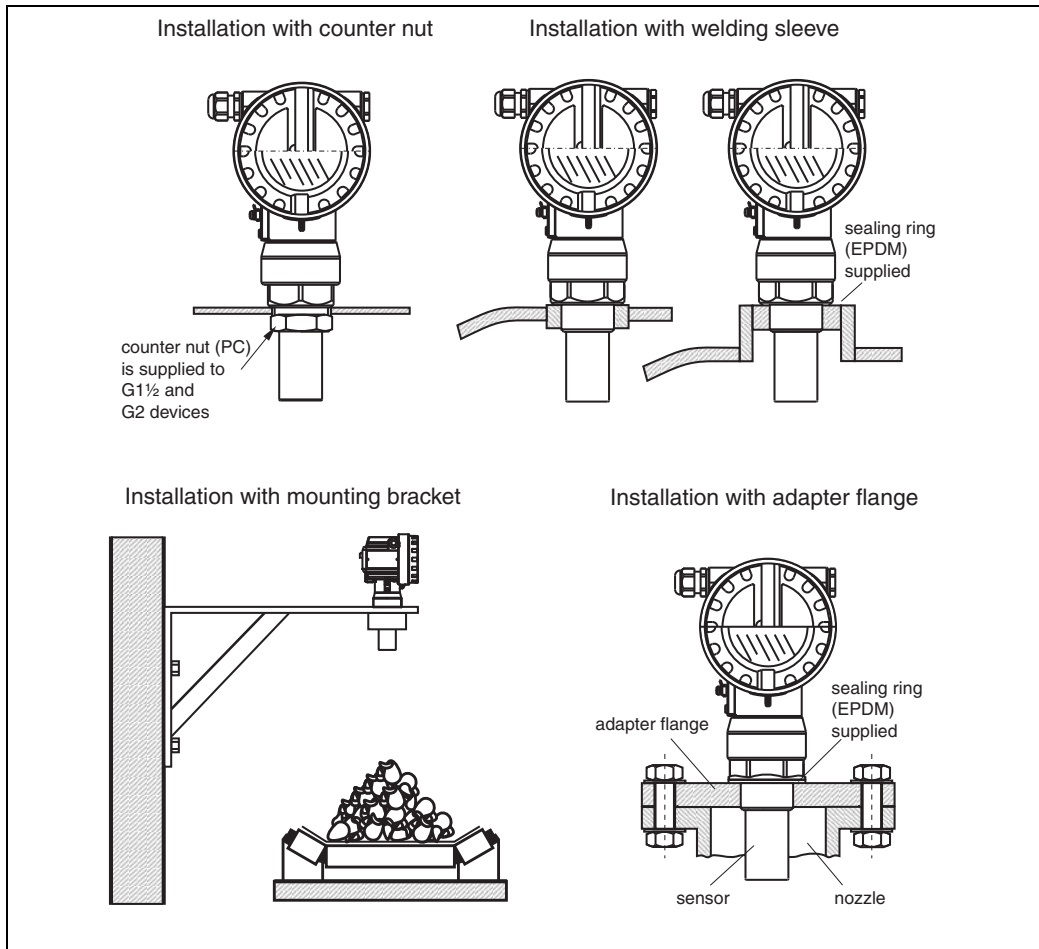

For mounting bracket or adapter flange see section "Accessories"

3.2.2 Installation variants LUC-M30

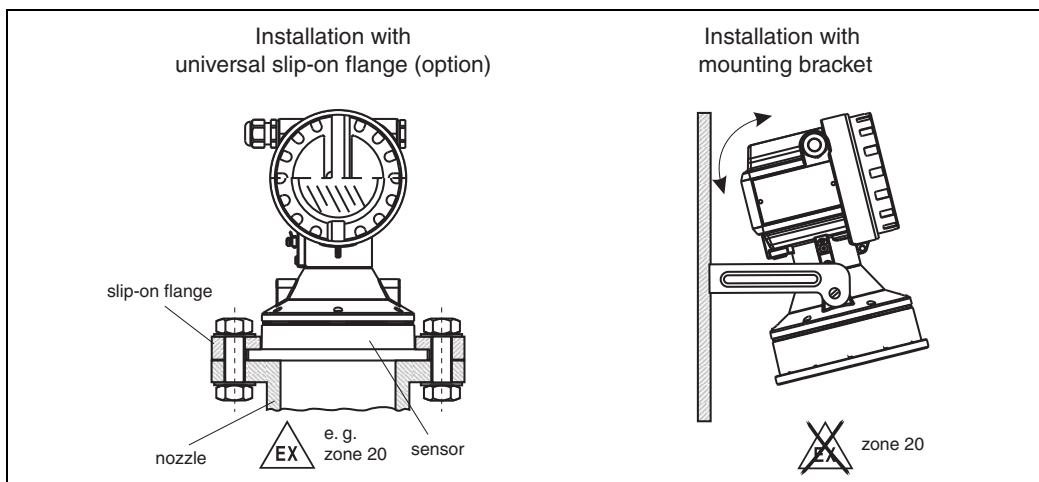

3.2.3 Installation variants LUC-M40

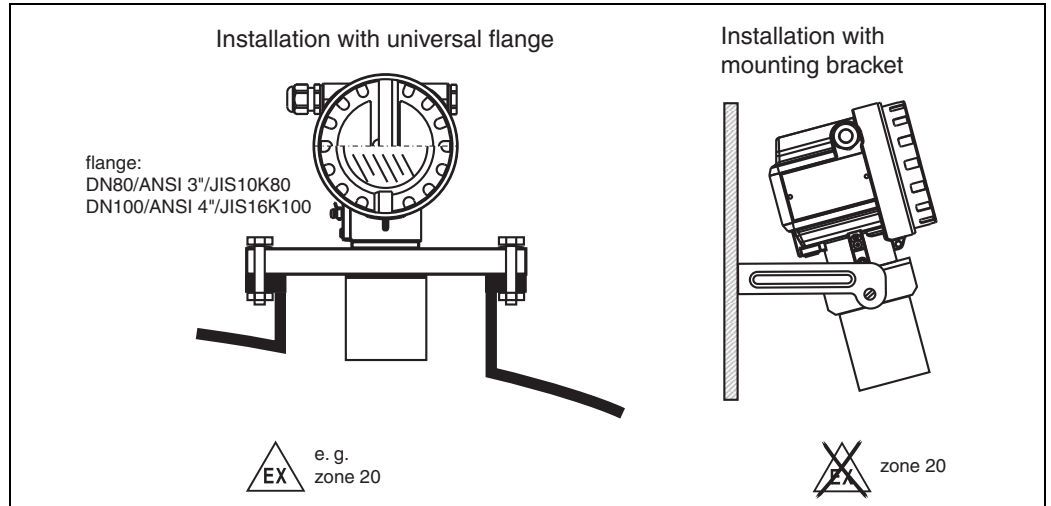

3.3 Installation conditions

3.3.1 Installation conditions for level measurements

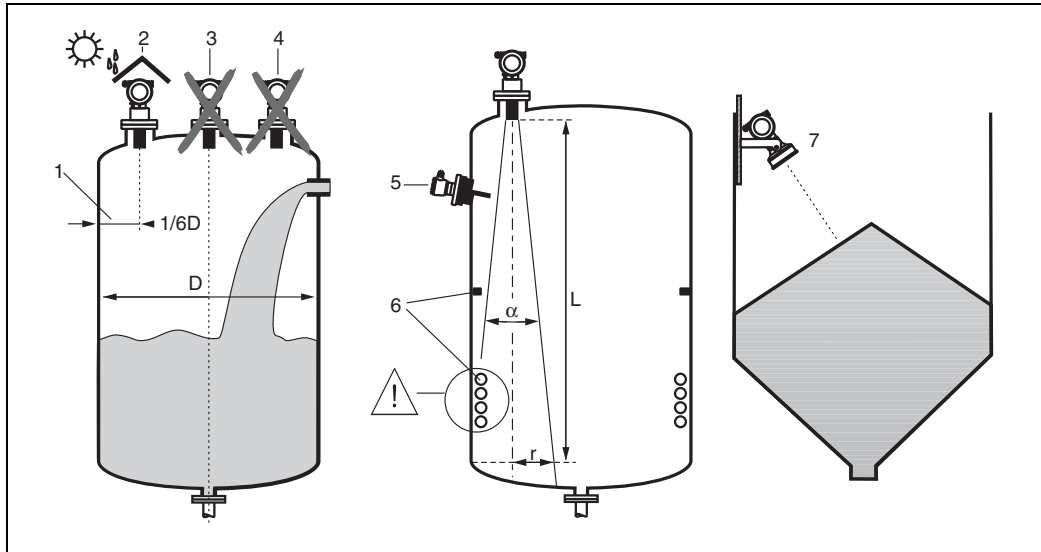

- Do not install the sensor in the middle of the tank (3). We recommend leaving a distance between the sensor and the tank wall (1) measuring 1/6 of the tank diameter.
- Use a protective cover, in order to protect the device from direct sun or rain (2).
- Avoid measurements through the filling curtain (4).
- Make sure that equipment (5) such as limit switches, temperature sensors, etc. are not located within the emitting angle α . In particular, symmetrical equipment (6) such as heating coils, baffles etc. can influence measurement.
- Align the sensor so that it is vertical to the product surface (7).
- Never install two ultrasonic measuring devices in a tank, as the two signals may affect each other.
- To estimate the detection range, use the 3 dB emitting angle α :

Sensor	α	L_{\max}	r_{\max}
LUC-M10	11°	5 m	0.48 m
LUC-M20	11°	8 m	0.77 m
LUC-M30	6°	15 m	0.79 m
LUC-M40	9°	10 m	0.96 m

3.3.2 Installation in narrow shafts

In narrow shafts with strong interference echoes, we recommend using an ultrasound guide pipe (e. g. PE or PVC wastewater pipe) with a minimum diameter of 100 mm.

Make sure that the pipe is not soiled by accumulated dirt. If necessary, clean the pipe at regular intervals.

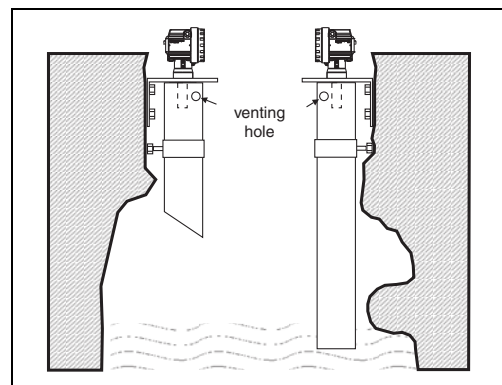

3.3.3 Installation conditions for flow measurements

- Install the LUC-M** at the inflow side, as close above the maximum water level H_{max} as possible (take into account the blocking distance BD).
- Position the LUC-M** in the middle of the channel or weir.
- Align the sensor membrane parallel to the water surface.
- Keep to the installation distance of the channel or weir.
- You can enter the "flow to level" linearisation curve ("Q/h curve") using via the on-site display.

Example: Khafagi-Venturi flume

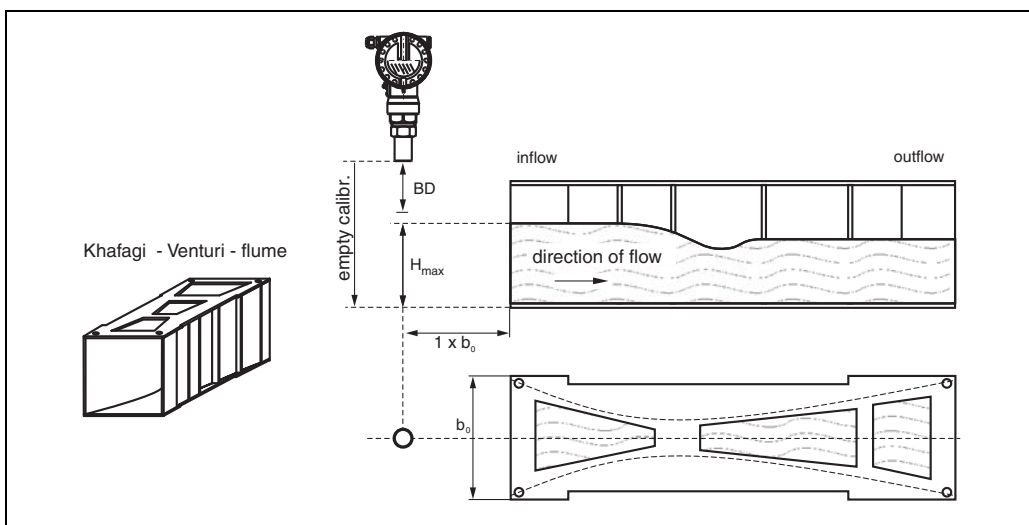

Example: Triangular weir

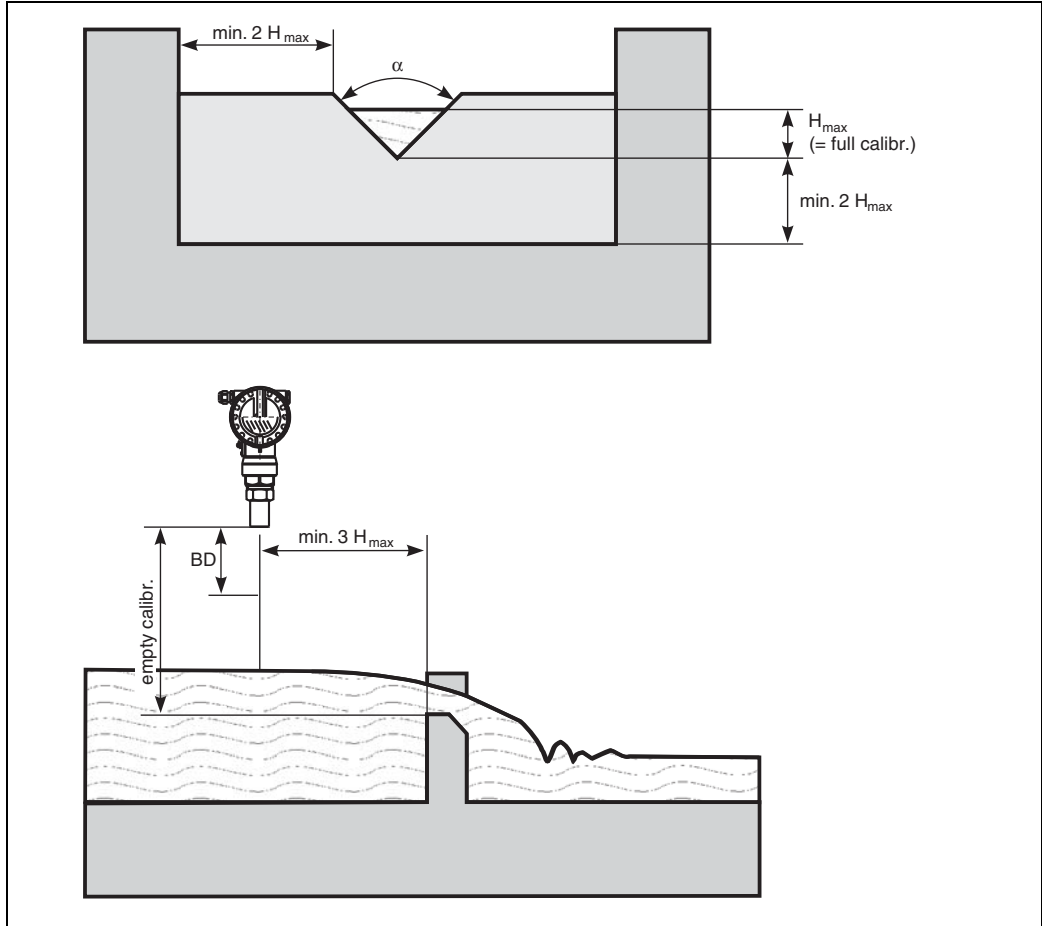

3.4 Measuring range

3.4.1 Blocking distance, nozzle mounting

Install the LUC-M** at a height so that the blocking distance BD is not undershot, even at maximum fill level. Use a pipe nozzle if you cannot maintain the blocking distance in any other way. The interior of the nozzle must be smooth and may not contain any edges or welded joints. In particular, there should be no burr on the inside of the tank side nozzle end. Note the specified limits for nozzle diameter and length. To minimise disturbing factors, we recommend an angled socket edge (ideally 45°).

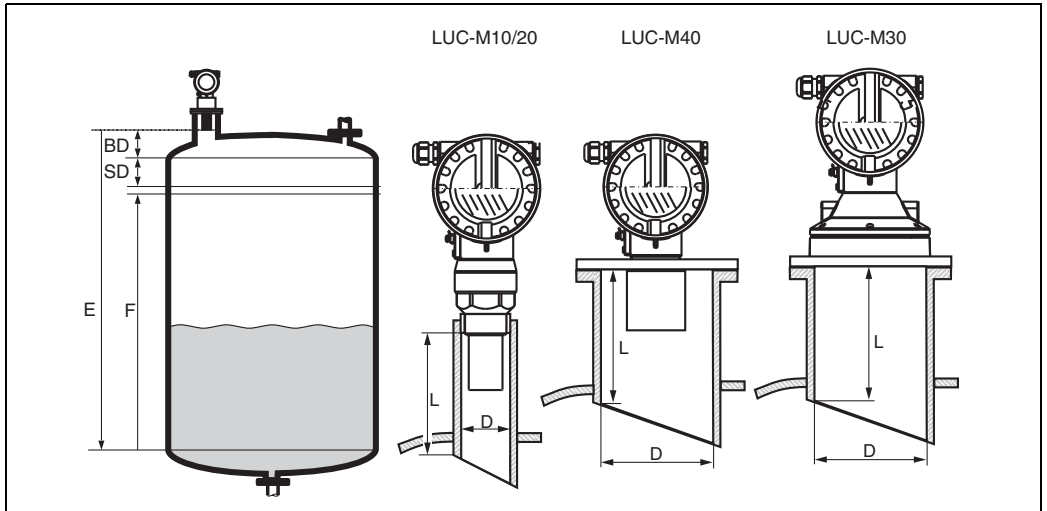

BD: blocking distance; **SD:** safety distance; **E:** empty calibration; **F:** full calibration (span); **D:** nozzle diameter; **L:** nozzle length

Nozzle diameter D	Maximum nozzle length L			
	LUC-M10	LUC-M20	LUC-M30	LUC-M40
DN50/2"	80 mm			
DN80/3"	240 mm	240 mm		250 mm
DN100/4"	300 mm	300 mm	300 mm	300 mm
DN150/6"	400 mm	400 mm	300 mm	400 mm
DN200/8"	400 mm	400 mm	300 mm	400 mm
DN250/10"	400 mm	400 mm	300 mm	400 mm
DN300/12"	400 mm	400 mm	300 mm	400 mm
Emitting angle α	11°	11°	6°	9°
Blocking distance	0.25 m	0.35 m	0.6 m	0.4 m
Max. range in liquids	5 m	8 m	15 m	10 m
Max. range in solids	2 m	3,5 m	7 m	5 m



Caution!

If the blocking distance is undershot, it may cause device malfunction.

3.4.2 Safety distance

If the level rises to the safety distance SD, the device switches to warning or alarm status.

The size of SD can be set freely in the "**Safety distance**" (015) function. The "**in safety distance**" (016) function defines how the device reacts if the level enters the safety distance.

There are three options:

- **Warning:** The device outputs an error message but continues measurement.
- **Alarm:** The device outputs an error message. The output signal assumes the value defined in the "**Output on alarm**" (011) function (MAX, MIN, user-specific value or holds the last value). As soon as the level drops below the safety distance, the device recommences measurement.
- **Self holding:** The device reacts in the same way as for an alarm. However, the alarm condition continues after the level drops below the safety distance. The device only recommences measurement when you cancel the alarm using the "**Ackn. alarm**" (017) function.

3.4.3 Range

The sensor range is dependent on the measuring conditions. Refer to Technical Information TI 365O/98/en for an estimation. The maximum range is shown in the above diagram (valid for good conditions).

Sensor	Maximum range
LUC-M10	5 m
LUC-M20	8 m
LUC-M30	15 m
LUC-M40	10 m

3.5 Installation hint for LUC-M10/20

Screw the LUC-M** at the screw-in piece using an AF60 spanner.

Maximum torque: 20 Nm.

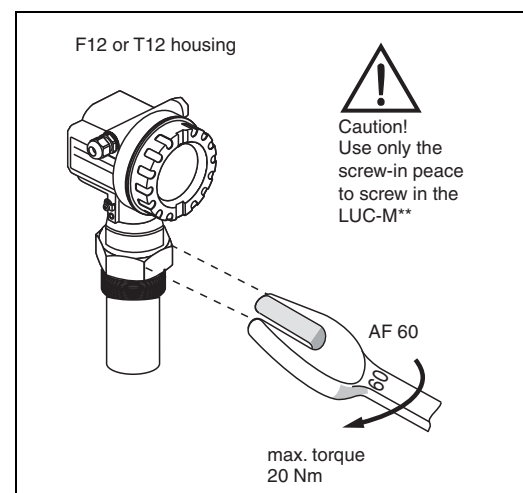

3.6 Turn housing

After mounting, the housing can be turned 350° in order to simplify access to the display and the terminal compartment. Proceed as follows to turn the housing to the required position:

- undo the fixing screws (1)
- turn the housing (2) in the required direction
- tighten up the fixing screws (1). Maximum torque 0.5 Nm
- Loctite can be used for securing the screw.

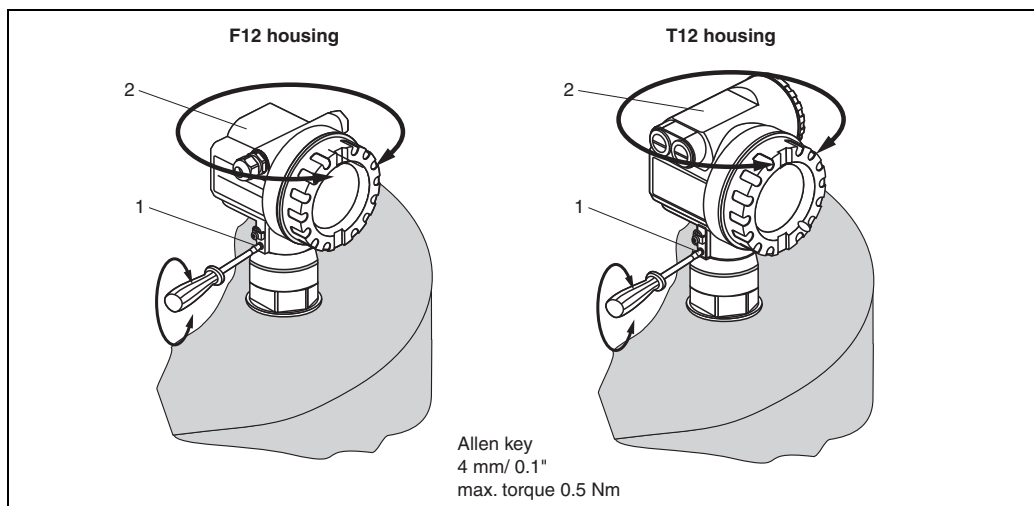

3.7 Installation check

After installing the device, carry out the following checks:

- Is the device damaged (visual inspection)?
- Does the device correspond to the measuring point specifications for process temperature, process pressure, ambient temperature, measuring range etc.
- If available: Are the measuring point number and labelling correct (visual inspection)?
- Is the measuring device sufficiently protected against precipitation and direct sunlight?
- Are the cable glands tightened correctly?
- After aligning the housing, check the process seal at the nozzle or flange.

4 Wiring

4.1 Electrical connection



Caution!

Before connection please note the following:

- The power supply must be identical to the data on the nameplate.
- Switch off power supply before connecting up the instrument.
- Connect equipotential bonding to transmitter ground terminal before connecting up the instrument (s. section "Potential matching")



Warning!

When you use the measuring system in hazardous areas, make sure to comply with national standards and the specifications in the safety instructions (SI). Make sure you use the specified cable gland.

4.1.1 Wiring in the housing F12

1. Unscrew housing cover (1).
2. Remove display (2) if fitted.
3. Remove cover plate (3) from terminal compartment.
4. Pull out terminal module (4) slightly using pulling loop.
5. Insert cable (5) through gland (6).



Caution!

If possible, insert the cable from above and let a draining loop in order to avoid intrusion of humidity.

6. Connect cable screen to the grounding terminal (7) within the terminal compartment.
7. Make connection according to terminal assignment (see below).
8. Re-insert terminal module (4).
9. Tighten cable gland (6).
10. Tighten screws on cover plate (3).
11. Insert display (2) if fitted.
12. Screw on housing cover (1).
13. Switch on power supply.

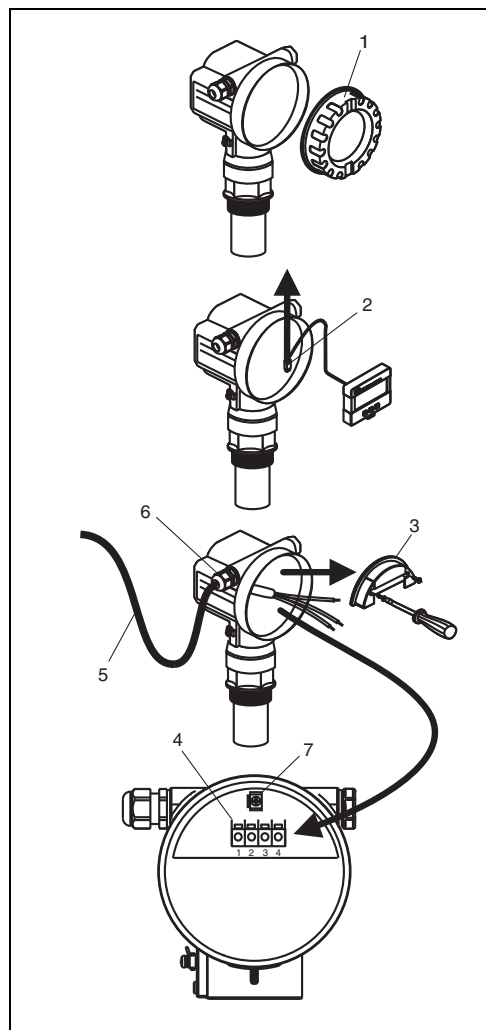

4.1.2 Wiring in the housing T12

1. Unscrew the cover (1) of the separate connection room.
2. Insert cable (2) through gland (3).
-  **Caution!**
If possible, insert the cable from above and let a draining loop in order to avoid intrusion of humidity.
3. Connect cable screen to the grounding terminal (4) within the connection room.
4. Make connection according to the terminal assignment (see below).
5. Tighten cable gland (3).
6. Screw on housing cover (1).
7. Switch on power supply

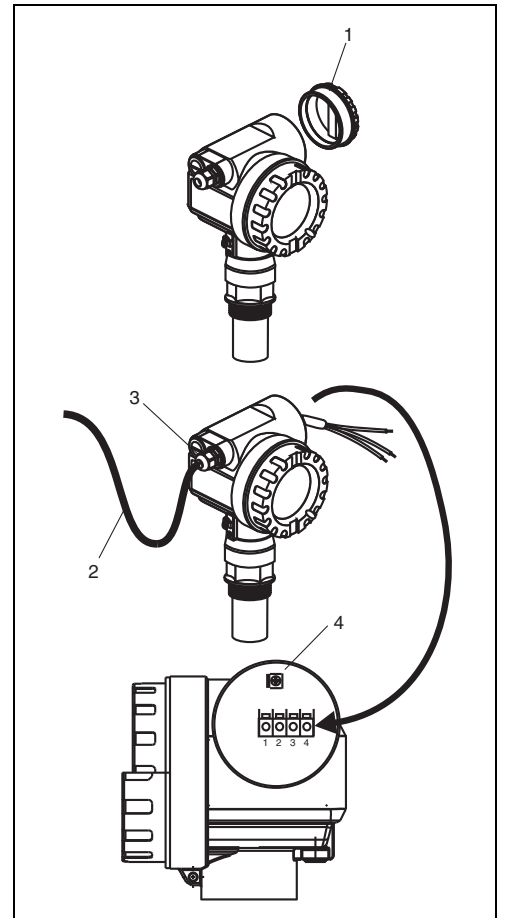

4.2 Terminal assignment

HART, 2-wire version

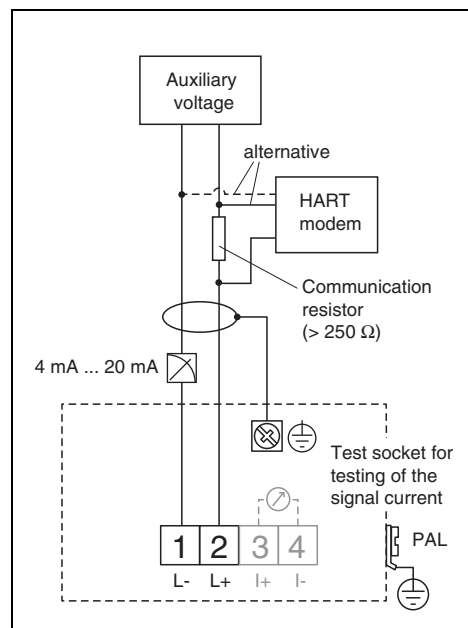

HART, 4-wire version, active

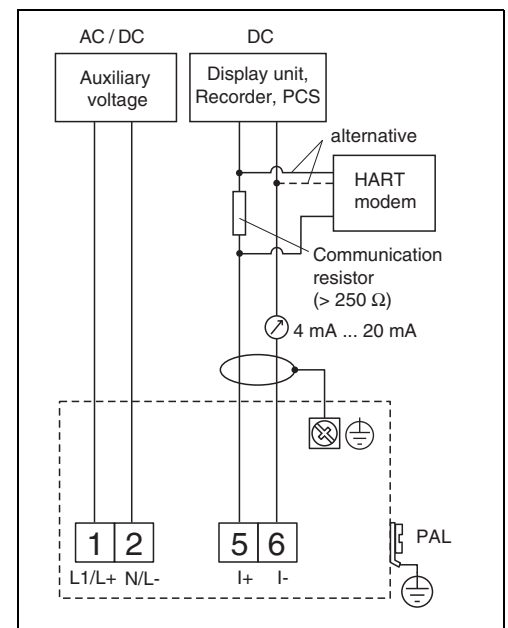

4.3 Supply voltage

4.3.1 HART, 2-wire

The following values are the voltages across the terminals directly at the instrument:

Version		Current consumption	Terminal voltage minimum	Terminal voltage maximum
2-wire HART	standard	4 mA	14 V	36 V
		20 mA	8 V	36 V
	EEx ia	4 mA	14 V	30 V
		20 mA	8 V	30 V
	EEx d	4 mA	14 V	30 V
		20 mA	11 V	30 V
Fixed current, adjustable, e. g. for solar power operation (measured value via HART)	standard	11 mA	10 V	36 V
	EEx ia	11 mA	10 V	30 V
Fixed current for HART multidrop mode	standard	4 mA ¹	14 V	36 V
	EEx ia	4 mA ¹	14 V	30 V

1) Start-up current 11 mA

4.3.2 HART, 4-wire

Version	Voltage	Max. load
DC	10.5 V ... 32 V	600 Ω
AC 50/60 Hz	90 V ... 253 V	600 Ω



Caution!

When using the public powers supply, install an easy accessible power switch in the proximity of the instrument. Mark the power switch as a disconnecter for the instrument (IEC/EN 61010).

4.4 Potential matching

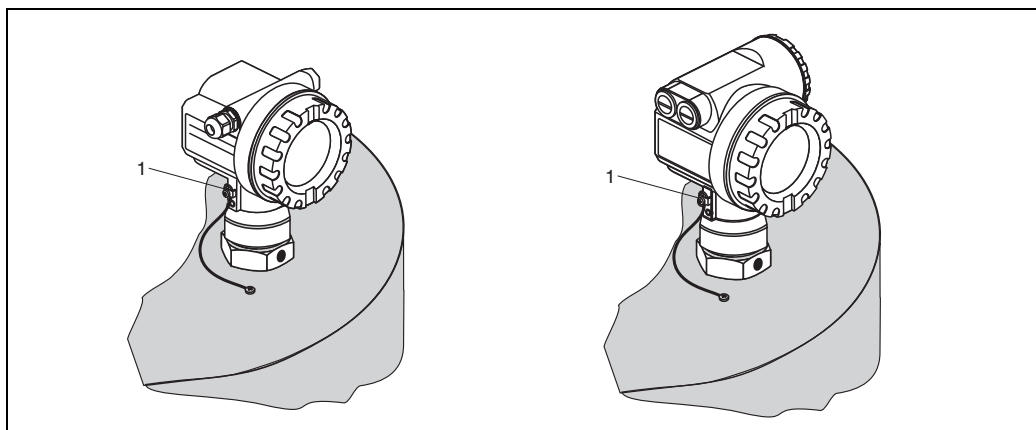

1: external ground terminal of the transmitter

Connect the equipotential bonding to the external ground terminal of the transmitter.



Caution!

In Ex applications, the instrument must only be grounded on the sensor side. Further safety instructions are given in the separate documentation for applications in explosion hazardous areas.



Note!

Since the housing is isolated from the tank by the plastic sensor, interference signals may occur if the potential matching line is not properly connected. For optimum electromagnetic compatibility the potential matching line should be as short as possible and at least 2.5 mm² in cross-section. If increased electromagnetic interference is to be expected due to the installation conditions, we recommend usage of a ground strap.

4.5 Checking the connection

After wiring the device, carry out the following checks:

- Are the terminals correctly assigned?
- Is the cable gland tight?
- Is the housing cover fully screwed on?
- If power supply available: Does a display appear on the display module?

5 Operation

5.1 Display and operating elements

5.1.1 On-site display LUC-Z15

The LCD module LUC-Z15 for display and operation is located beneath the housing cover. The measured value is legible through the glass in the cover. Open the cover to operate the device.

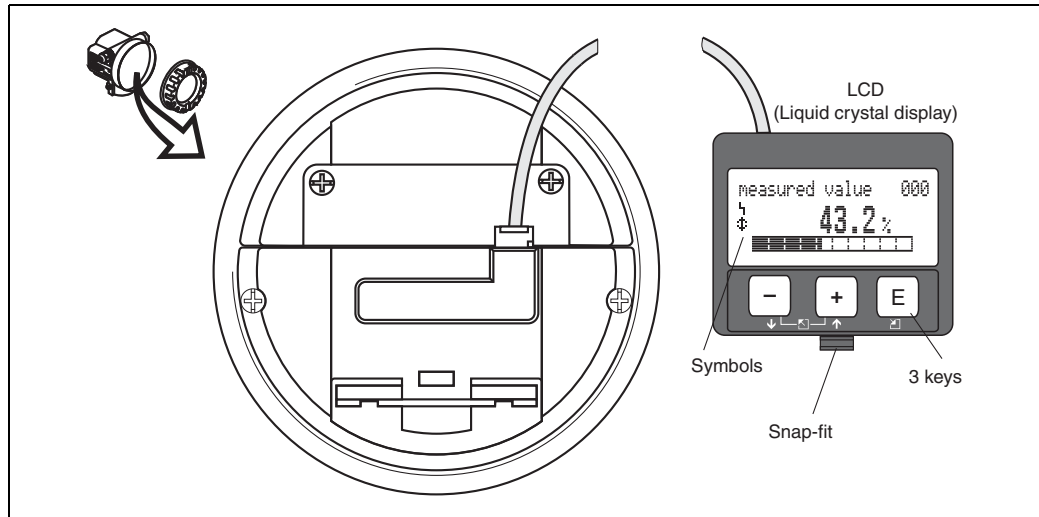

5.1.2 Display appearance

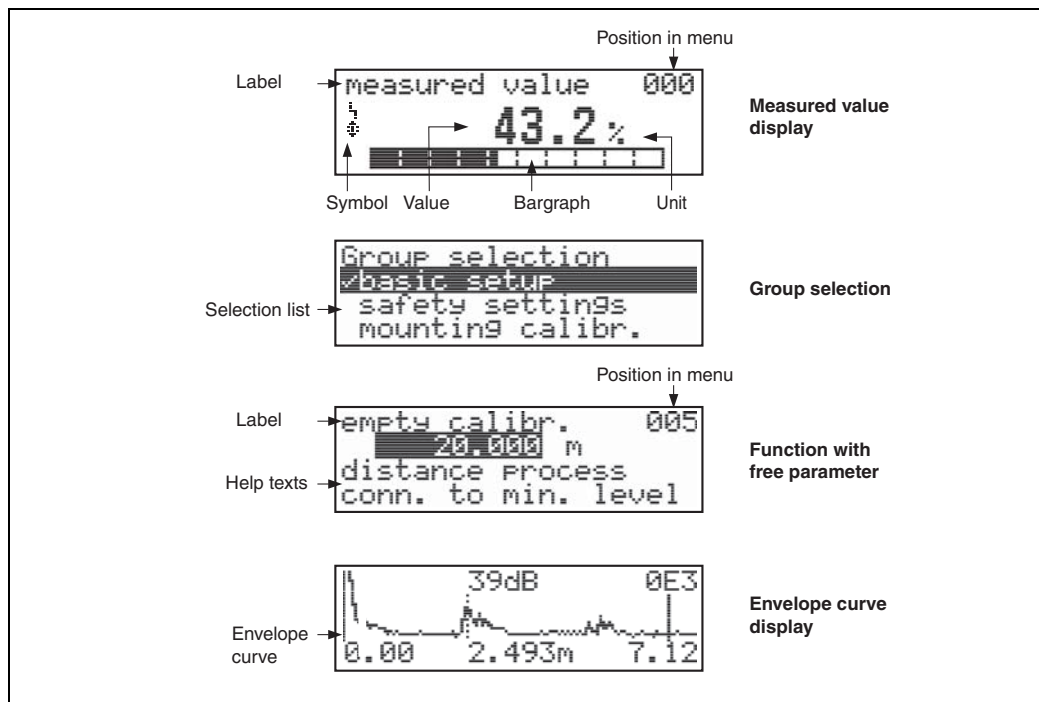



In the measured value display, the bargraph corresponds to the output.















The bargraph is segmented in 10 bars. Each completely filled bar represents a change of 10 % of the adjusted span.

5.1.3 Display symbols

The following table describes the symbols that appear on the liquid crystal display:

Symbol	Meaning
	ALARM_SYMBOL This alarm symbol appears when the instrument is in an alarm state. If the symbol flashes, this indicates a warning.
	LOCK_SYMBOL This lock symbol appears when the instrument is locked, i. e. if no input is possible.
	COM_SYMBOL This communication symbol appears when a data transmission via e. g. HART or PROFIBUS PA is in progress.

5.1.4 Function of the keys

Key(s)	Meaning
 or 	Navigate upwards in the selection list Edit numeric value within a function
 or 	Navigate downwards in the selection list Edit numeric value within a function
 or 	Navigate to the left within a function group
	Navigate to the right within a function group, confirmation
 and  or  and 	Contrast settings of the LCD
 and  and 	Hardware lock/unlock After a hardware lock, an operation of the instrument via display or communication is not possible! The hardware can only be unlocked via the display. An unlock parameter must be entered to do so.

5.2 Function codes

For easy orientation within the function menus, for each function a position is shown on the display.

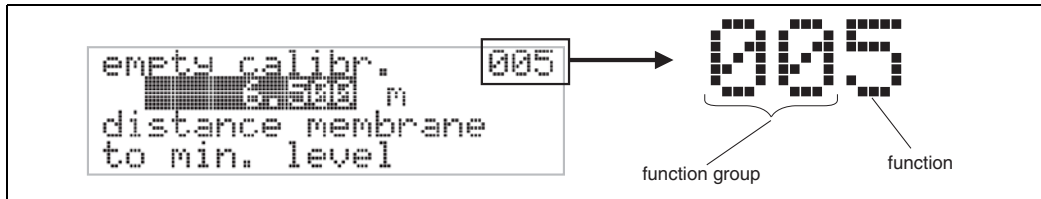

The first two digits identify the function group:

- **basic setup** **00**
- **safety settings** **01**
- **linearisation** **04**
- ...

The third digit numbers the individual functions within the function group:

- **basic setup** **00** →
- **tank shape** **002**
- **medium property** **003**
- **process cond.** **004**
- ...

Hereafter the position is always given in brackets (e. g. "**tank shape**" (**002**)) after the described function.

5.3 Operating options

5.3.1 4 mA ... 20 mA output with HART protocol

The complete measuring system consists of:

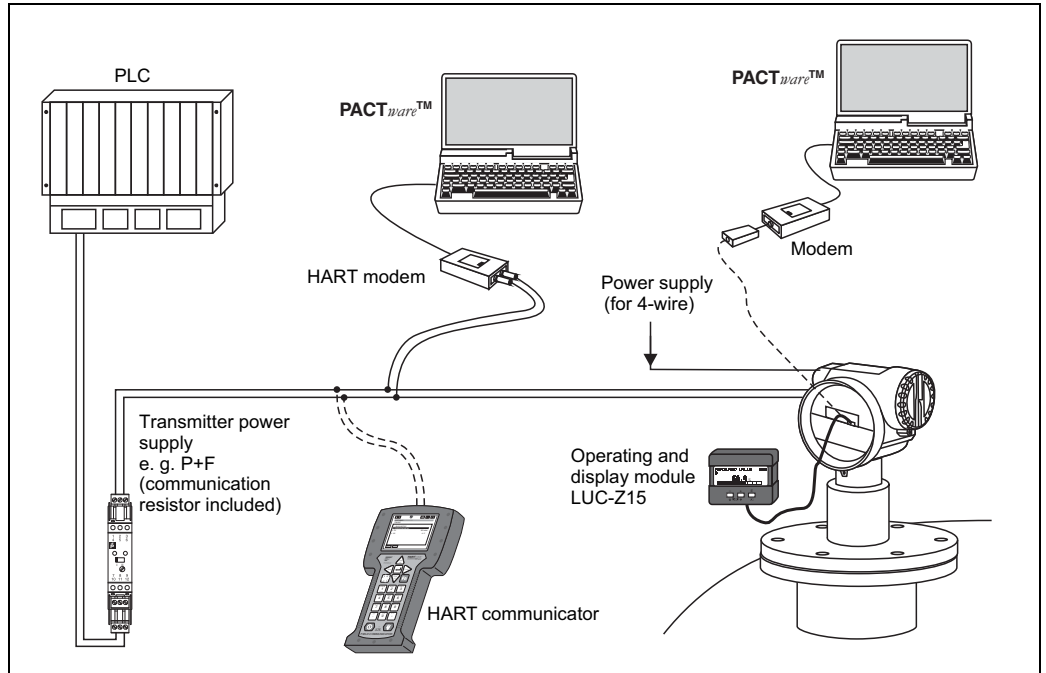

If the HART communication resistor is not built into the supply unit, it is necessary to insert a communication resistor of 250 Ω into the 2-wire line.

5.4 Operation using the on-site display LUC-Z15

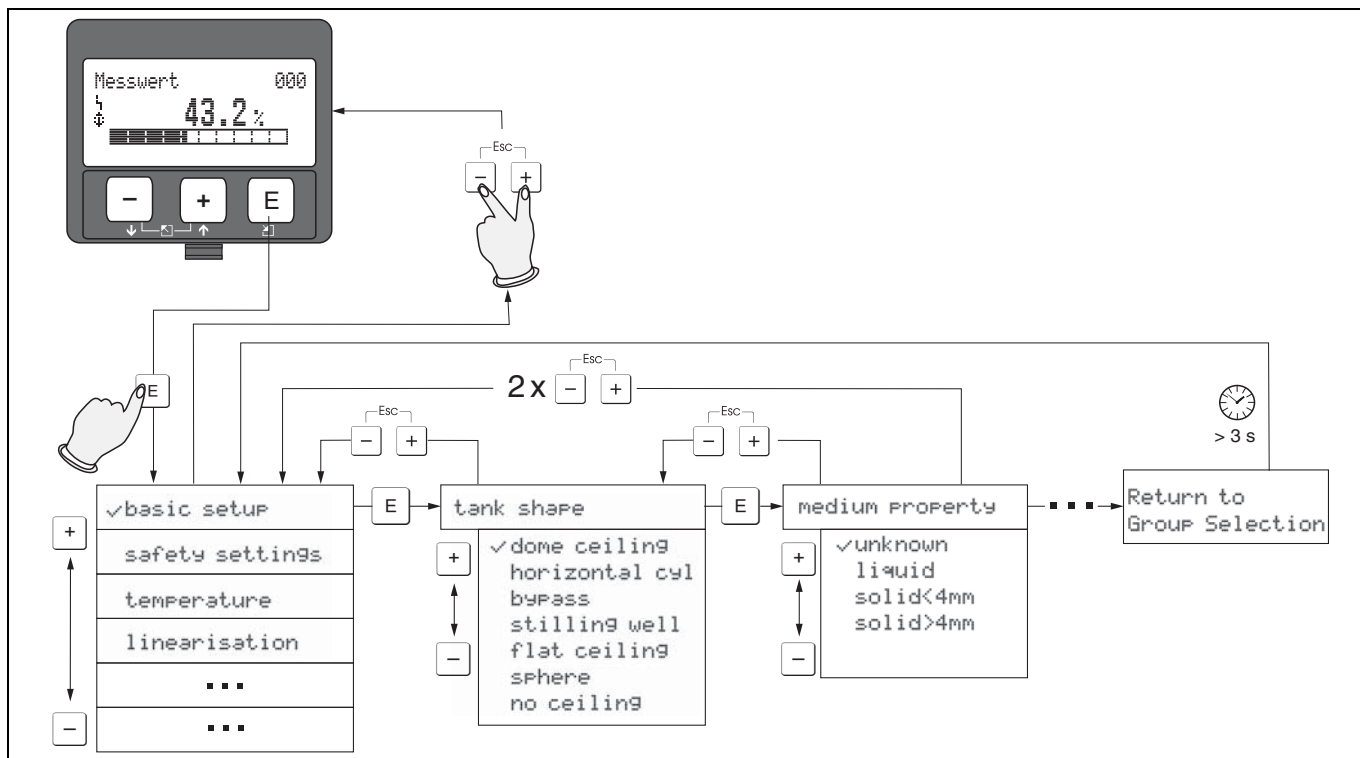

1. Change from Measured Value Display to **Group Selection** by pressing **E**.
2. Press **-** or **+** to select the required **Function Group** and confirm by pressing **E**. The active selection is marked by a ✓ in front of the menu text.
3. Activate Edit mode with **+** or **-**.

Selection menus

- a. Select the required **Parameter** in selected **function** with **-** or **+**.
- b. **E** confirms selection → ✓ appears in front of the selected parameter.
- c. **E** confirms the edited value → system quits edit mode.
- d. **+** and **-** (= **↔**) interrupts selection → system quits edit mode.

Typing in numerals and text

- a. Press **+** or **-** to edit the first character of the **numeral/text**.
 - b. **E** positions the cursor at the next character → continue with a. until you have completed your input.
 - c. If a ↓ symbol appears at the cursor, press **E** to accept the value entered → system quits edit mode.
 - d. If a ← symbol appears at the cursor, press **E** to return to the previous character (e. g. for correction of entries).
 - e. **+** and **-** (= **↔**) interrupts selection; → system quits edit mode.
4. Press **E** to select the next **function**.
 5. Press **+** and **-** (= **↔**) once → return to previous **function**.
Press **+** and **-** (= **↔**) twice → return to **Group Selection**.
 6. Press **+** and **-** (= **↔**) to return to **Measured value display**.

5.5 Operation using PACT^{ware}TM

PACT^{ware}TM is an operating software with graphical support (MS Windows) for intelligent transmitters with the communication protocols HART and PROFIBUS PA.

PACT^{ware}TM supports the following functions:

- Online configuration of transmitters
- Loading and saving of instrument data (Upload/Download)
- Orderly visualisation of measured values and limit values
- Display and recording of measured values with a line recorder

5.5.1 Operation

You make the settings using an operating matrix or via a graphic interface. Envelope curves can not be display in PACT^{ware}TM.

5.5.2 Connection

- HART with HART modem (available as accessory)
- PROFIBUS PA

5.6 Operation using the HART handheld terminal Field Communicator 375

The operating menu of the LUC-M** can be accessed via the HART handheld terminal 375.

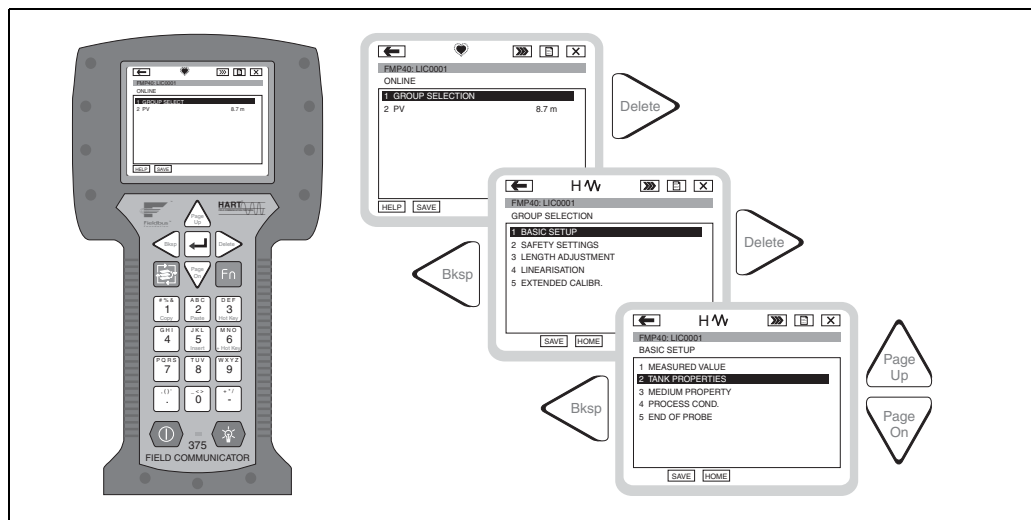

Connect the handheld terminal directly to the HART communication line.

5.7 Lock/unlock configuration

5.7.1 Software security locking

Enter a number $\neq 100$ in the "unlock parameter" (0A4) function in the "diagnostics" (0A) function group.

The  symbol appears on the display. Inputs are no longer possible.

If you try to change a parameter, the device jumps to the "unlock parameter" (0A4) function. Enter "100".

Now change the parameters.

5.7.2 Hardware security locking

Press ,  and  simultaneously.

Inputs are no longer possible.

If you try to change a parameter, the following appears:



```
unlock Parameter 0A4
& Hardware locked
```

Press ,  and  simultaneously. The "unlock parameter" (0A4) function appears. Enter "100"

Now change the parameters.



Note!

A hardware locking can **only** be unlocked again via the display by pressing the ,  and  keys at the same time again. It is **not** possible to unlock the hardware by communication.

5.8 Resetting the customer parameters

It is advisable to reset the customer parameters if you want to use a device with an unknown history.

Effects of resetting:

- All customer parameters are reset to their default values.
- Customer interference echo suppression is **not** deleted.
- Linearisation is switched to "**linear**", but the table values are kept. The table can be switched back on in the "**linearisation**" (04) function group in the "**linearisation**" (041) function.

In order to carry out the reset, enter the number "333" in the "reset" (0A3) function in the "diagnostics" (0A) function group.



Caution!

A reset may lead to impairment of the measurement. As a rule, a basic calibration is required after a reset.



Note!

The default values of each parameter are shown in bold in the menu overview in the appendix.

5.9 Resetting an interference echo suppression (tank map)

It is always advisable to reset the interference echo suppression (tank mapping) when:

- a device with an unknown history is used
- an incorrect suppression was input.

Proceed as follows:

1. Switch to the "**extended calibr.**" (05) function group and to the "**selection**" (050) function.
2. Select "**extended map.**"
3. Then proceed to the "**cust. tank map**" (055) function.
4. Select
 - "**reset**", to delete (reset) the existing interference echo suppression.
 - "**inactive**" to deactivate an existing interference echo suppression. The suppression remains saved.
 - "**active**" to reactivate an existing interference echo suppression.

6.2 Basic calibration

The "**Basic setup**" (00) function group lists all the functions which are required for a standard measurement task to commission the LUC-M**. When you have completed your input for a function, the next function appears automatically. In this way, you are guided through the complete calibration.

6.2.1 Measuring point settings

Function "tank shape" (002)

In this function, select one of the following options:

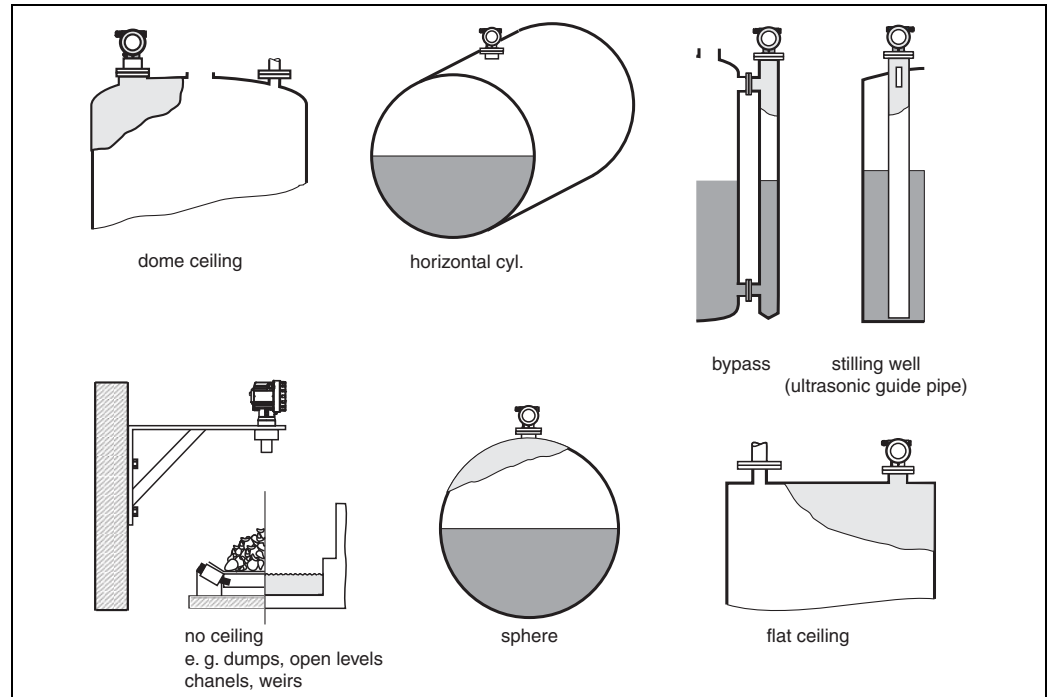

Function "medium property" (003)

Set the medium type in this function.

You have the following options:

- unknown (e. g. pasty media such as greases, creams, gels etc.)
- liquid
- solid, grain size < 4mm (fine)
- solid, grain size > 4mm (coarse)

Function "process conditions" (004)

For this function, you have the following options:

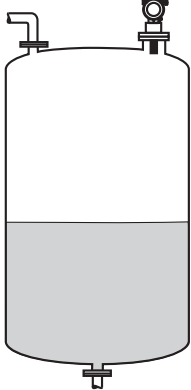
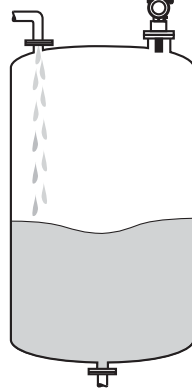
Standard liquids	Calm surface	Turb. surface
For all fluid applications which do not fit in any of the following groups.	Storage tanks with immersion tube or bottom filling	Storage/accumulation tanks with uneven surface due to free filling, mixing nozzles or small bottom stirrers.
		
The filters and output damping are set to average values.	The averaging filters and output damping are set to large values. <ul style="list-style-type: none"> - stable measured value - accurate measurement - slow reaction time 	Special filters for stabilising the input signal are activated. <ul style="list-style-type: none"> - stable measured value - medium reaction time

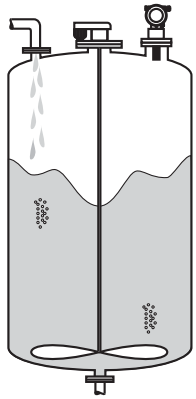
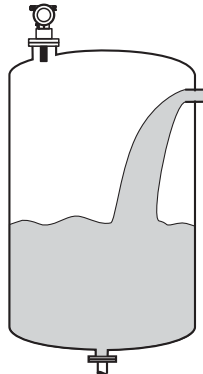
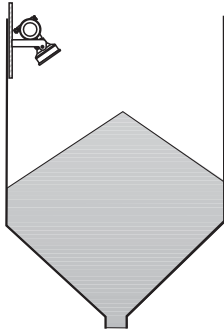
Add. agitator	Fast change	Standard solid
Moving surfaces (poss. with vortex formation) due to agitators	Rapid level change, particularly in small tanks	For all bulk solids applications which do not fit in any of the following groups.
		
Special filters for stabilising the input signal are set to large values. <ul style="list-style-type: none"> - stable measured value - medium reaction time 	The averaging filters are set to small values. <ul style="list-style-type: none"> - rapid reaction time - possibly unstable measured value 	The filter and output damping are set to average values.

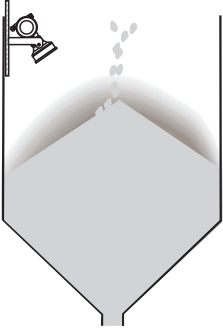
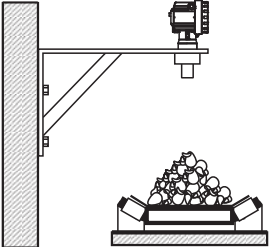
Solid dusty	Conveyor belt	Test:no filter
Dusty bulk solids	Bulk solids with rapid level change	All the filters can be switched off for purposes of service and diagnosis.
		
The filters are set to detect even relatively weak signals.	The averaging filters are set to small values. <ul style="list-style-type: none"> - rapid reaction time - possibly unstable measured value 	All filters off

6.2.2 Empty and full calibration

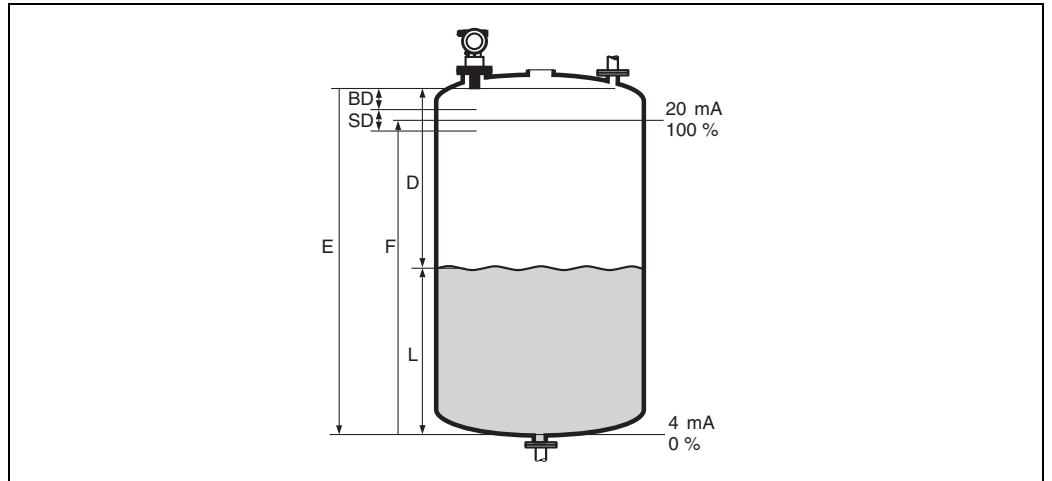

Function "empty calibration" (005)

In this function, enter the distance E from the sensor membrane to the minimum level (zero point).



Caution!

With dished boiler heads or conical outflows, the zero point should not be deeper than the point at which the ultrasonic wave impinges on the tank bottom.

Function "blocking distance" (059)

In this function the blocking distance (BD) of the sensor is displayed.



Caution!

When entering the full calibration (span), please take into account, that the maximum level may not project into the blocking distance (BD).



Note!

After basic calibration, enter a safety distance (SD) in the "**safety distance**" (015) function. If the level is within this safety distance, the LUC-M** signals a warning or an alarm, depending on your selection in the "**in safety distance**" (016) function.

Function "full calibration" (006)

In this function, enter the span F, i. e. the distance from the minimum level to the maximum level.

6.2.3 Interference echo suppression (tank mapping)

Function "dist./meas.value" (008)

In the "dist./meas.value" (008) function, the measured distance D from the sensor membrane to the product surface is displayed together with level L. Check these values.

Function "check distance" (051)

The mapping is initialized by this function.

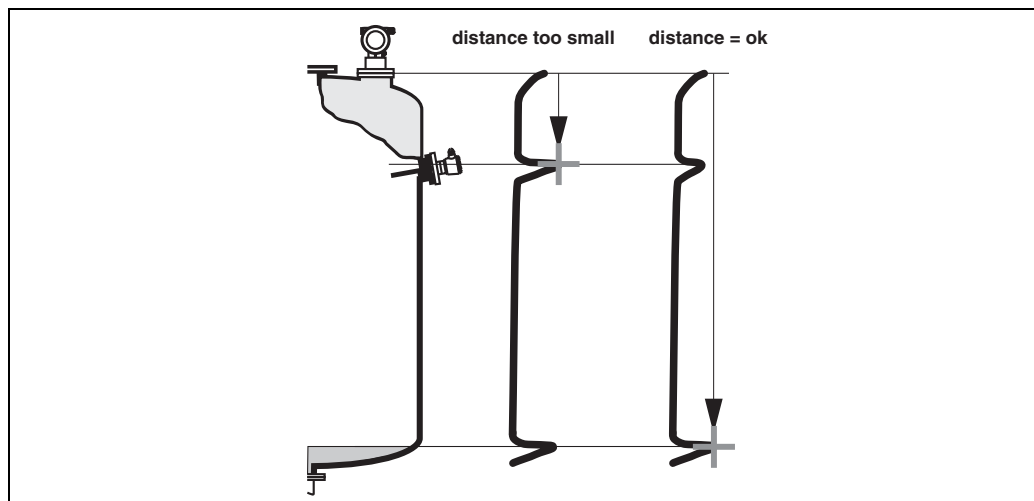

Select

- "**distance=ok**" if the correct distance is displayed. Any echoes closer to the sensor will be suppressed by the following interference echo suppression.
- "**dist. too small**" if the displayed distance is too small. In this case, the signal comes from an interference echo which will be suppressed.
- "**dist. too big**" if the displayed distance is too large. This error cannot be cancelled by suppressing the interference echo. This means that the following two functions are skipped. Check the application parameters "**tank shape**" (002), "**medium property**" (003) and "**process cond.**" (004) and the "**empty calibr.**"(005) in the "**basic setup**" (00) function group.
- "**dist. unknown**" if you do not know the actual distance. This means that the following two functions are skipped.
- "**manual**" if you want to specify the suppression area yourself in the following function.

Function "range of mapping" (052)

The suggested suppression area is displayed in this function. The reference point is always the sensor membrane. You can still edit the value. With manual suppression, the default value is 0 m.



Caution!

The suppression range must end 0.5 m in front of the echo of the actual level. With an empty tank, do not enter E but E – 0.5 m.

Function "start mapping" (053)

You have the following options for this function:

- **off**: nothing is suppressed.
- **on**: starts suppression.



Note!

If a mapping already exists, it will be overwritten up to the distance specified in the "**range of mapping**" (052) function. Beyond this distance the existing mapping remains unchanged.

Function dist./meas.value (008)

After suppression, the measured distance D from the sensor membrane to the product surface is displayed together with the level. Check that the values correspond to the actual level and/or the actual distance.

The following cases may occur:

- Distance correct – Level correct → end of basic calibration.
- Distance incorrect – Level incorrect → an additional interference echo suppression must be carried out. Go back to the "**check distance**" (051) function.
- Distance correct – Level incorrect → check the value of the "**empty calibr.**" (005) function.

Return to group selection

After the interference echo suppression the basic setup is terminated and the device reset automatically into the group selection.

6.3 Envelope curve

After the basic setup, an evaluation of the measurement with the aid of the envelope curve ("**envelope curve**" (0E) function group) is recommended.

6.3.1 Function "plot settings" (0E1)

In this function, select whether you want to display

- just the envelope curve
- the envelope curve and the echo evaluation line FAC
- the envelope curve and interference echo suppression (map)



Note!

The FAC and the interference echo suppression (map) are explained in BA 2400, "Description of instrument functions".

6.3.2 Function "recording curve" (0E2)

In this function, specify whether you want to display

- an individual envelope curve
- the current envelope curve, with cyclical refreshment

6.3.3 Function "envelope curve display" (0E3)

The envelope curve is displayed in this function. You can use it to obtain the following information:

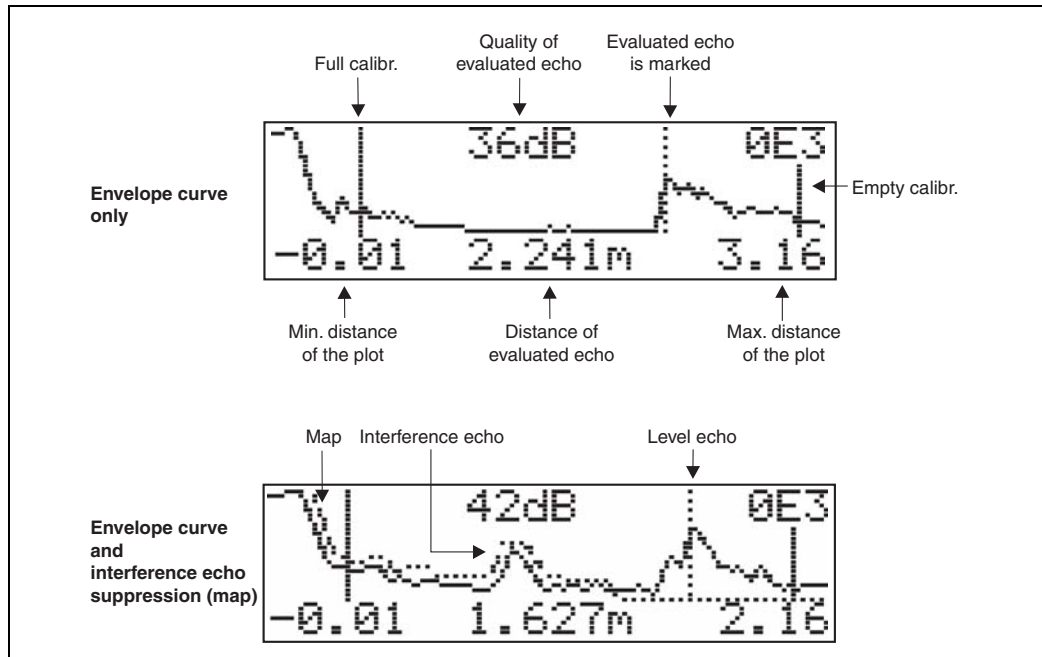

Check that the following conditions are fulfilled:

- The echo quality at the end of measuring range should be at least 10 dB.
- There should be practically no interference echoes in front of the level signal.
- If interference echoes cannot be avoided, they must be below the suppression curve.



Note!

If the cyclical envelope curve display is still active on the display, the measured value is updated at a slower cycle time. We therefore advise you to exit the envelope curve display after optimising the measuring point. To do this, press **E**. (The instrument does not leave the envelope curve display automatically.)

6.3.4 Navigation in the envelope curve display

Using navigation, the envelope curve can be scaled horizontally and vertically and shifted to the left or the right. The active navigation mode is indicated by a symbol in the top left hand corner of the display.

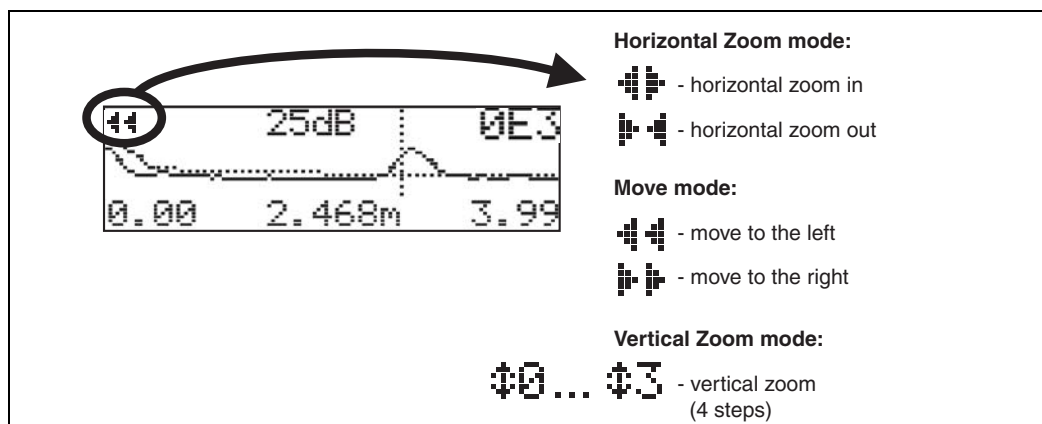

Horizontal zoom mode

Firstly, go into the envelope curve display. Then press $\boxed{+}$ or $\boxed{-}$ to switch to the envelope curve navigation. You are then in Horizontal Zoom mode. Either $\boxed{+}$ or $\boxed{-}$ is displayed.

- $\boxed{+}$ increases the horizontal scale.
- $\boxed{-}$ reduces the horizontal scale.

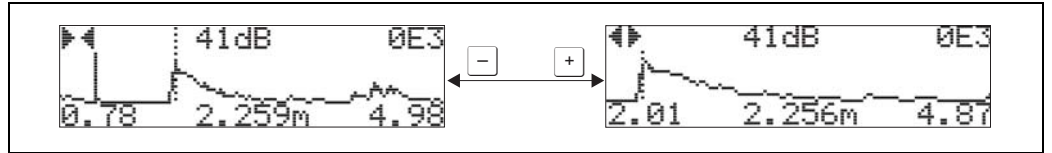

Move mode

Then press \boxed{E} to switch to Move mode. Either $\boxed{+}$ or $\boxed{-}$ is displayed.

- $\boxed{+}$ shifts the curve to the right.
- $\boxed{-}$ shifts the curve to the left.

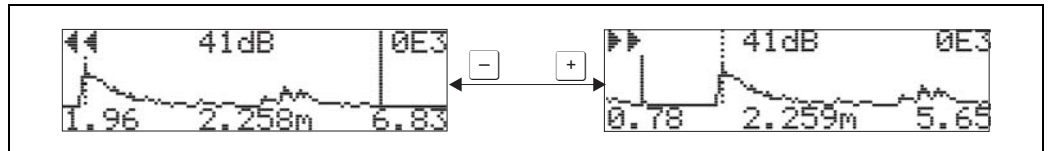

Vertical zoom mode

Press \boxed{E} once more to switch to Vertical Zoom mode. $\boxed{\updownarrow}$ is displayed. You now have the following options.

- $\boxed{+}$ increases the vertical scale.
- $\boxed{-}$ reduces the vertical scale.

The display icon shows the current zoom factor ($\boxed{\updownarrow 0}$ to $\boxed{\updownarrow 3}$).

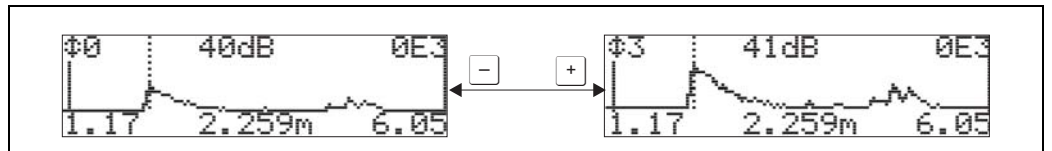

Exiting the navigation



- Press \boxed{E} again to run through the different modes of the envelope curve navigation.
- Press $\boxed{+}$ and $\boxed{-}$ to exit the navigation. The set increases and shifts are retained. Only when you reactivate the "recording curve" (0E2) function the display settings return to their standard values.

7 Troubleshooting

7.1 System error messages

7.1.1 Current error



Errors which the LUC-M** detects during commissioning or operation are displayed:

- In the "measured value" (000) function
- In the "diagnostics" (0A) function group in the "present error" (0A0) function
 Only the highest priority error is displayed; in the case of multiple errors, you can scroll between the different error messages by pressing  or .

7.1.2 Last error

The last error is displayed in the "diagnostics" (0A) function group in the "previous error" (0A1) function. This display can be deleted in the "clear last error" (0A2) function.

7.1.3 Types of error

Type of error	Symbol	Meaning
Alarm (A)	 continuous	The output signal assumes a value which can be set using the "output on alarm" (010) function: - MAX: 110 %, 22 mA - MIN: -10 %, 3.8 mA - Hold: last value is on hold - User-specific value
Warning (W)	 flashing	The device continues measurement. An error message is displayed.
Alarm/warning (E)	You can define whether the error should behave as an alarm or as a warning.	

7.1.4 Error codes

Code	Error description	Action
A102 A110 A152 A160	checksum error	Reset; If alarm still present after reset, replace electronics
W103	initialising	If the message does not disappear after several seconds, replace the electronics
A106	downloading	Wait; message disappears after load sequence
A111 A113 A114 A115 A121 A125 A155 A164 A171	electronics defect	Reset; Check system for EMC, improve as necessary If alarm still present after reset, replace electronics
A116	download error	Check connection; Restart download
W153	initialising	Wait a few seconds; if error is still displayed, switch the power off and on again
A231	sensor defect	Check connection, if necessary replace HF module or electronics
E281	interruption temperature sensor	Exchange sensor
A502	Sensor type not detected	Exchange sensor and/or electronics
A512	recording of mapping	Alarm disappears after a few seconds
A521	new sensor type detected	Reset
W601	linearisation curve not monotone	Correct table (enter monotonously increasing table)
W611	less than 2 linearisation points	Enter additional value pairs
W621	simulation on	Switch simulation mode off [" output " (06) function group, " simulation " (065) function]]
E641	no usable echo	Check basic calibration
E651	level in safety distance - risk of overspill	Error disappears when the level leaves the safety distance. Possibly reset the lock. [" safety settings " (01) function group, " ackn. alarm " (017) function]]
E661	Sensor overtemperature	
A671	Linearisation incomplete	Activate linearisation table
W681	current out of range	Carry out basic calibration; check linearisation
W691	Filling noise detected, level ramp is active	

7.2 Application errors

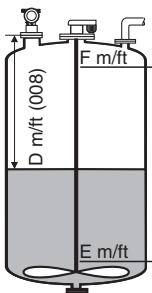
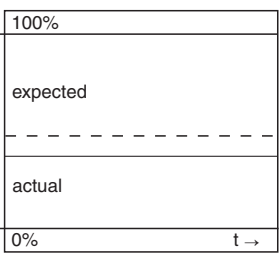
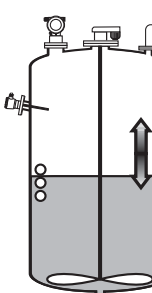
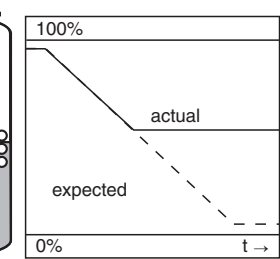
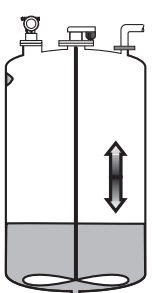
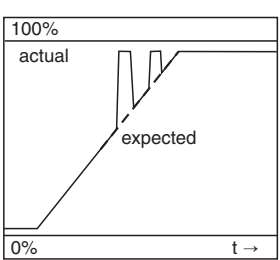
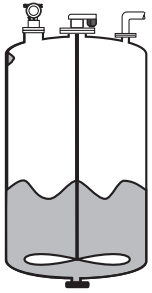
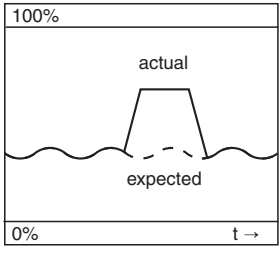
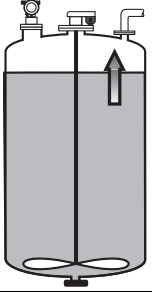
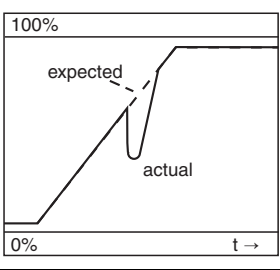
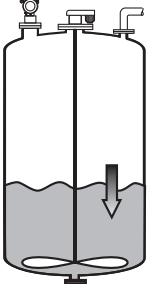
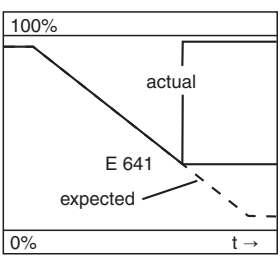
Error	Example	Elimination
"measured value" (000) is incorrect but "measured distance" (008) is correct	 	<ol style="list-style-type: none"> 1. Check "empty calibration" (005) and "full calibration" (006). 2. Check linearisation <ul style="list-style-type: none"> - "level/ullage" (040) - "max. scale" (046) - "diameter vessel" (047) - linearisation table
"measured value" (000) and "measured distance" (008) are incorrect	 	<ol style="list-style-type: none"> 1. For measurements in bypass or stilling well: Select the according option in the "tank shape" (002) function. 2. Carry out interference echo suppression.
No change in measured value on filling/emptying	 	<ol style="list-style-type: none"> 1. Carry out interference echo suppression. 2. Clean sensor if necessary 3. If necessary, select better installation position 4. If necessary due to wide interference echoes, set function "detection window" (0A7) to "off".
With an uneven surface (e. g. filling, emptying, running agitator) the measured value may jump sporadically to higher levels	 	<ol style="list-style-type: none"> 1. Carry out interference echo suppression 2. Set the "process cond." (004) to "calm surface" or "add. agitator" 3. Increase "output damping" (058). 4. If necessary, select a different installation position and/or a larger sensor
On filling/emptying the measured value drops	 	<ol style="list-style-type: none"> 1. Check "tank shape" (002), e. g. "dome ceiling" or "horizontal cyl." 2. If possible, do not select a central installation position 3. Possible user stilling well/echo guide pipe
E641 (echo loss)	 	<ol style="list-style-type: none"> 1. Check application parameters (002), (003) and (004) 2. If necessary, select a different installation position and/or a larger sensor 3. Align the sensor parallel to the product surface (particularly for bulk solids applications)

8 Maintenance and repairs

8.1 Exterior cleaning

When cleaning the exterior, always use cleaning agents that do not attack the surface of the housing and the seals.

8.2 Repairs

The Pepperl+Fuchs repair concept assumes that the measuring devices have a modular design and that customers are able to undertake repairs themselves.

Spare parts are contained in suitable kits. They contain the related replacement instructions.

All the spare parts kits which you can order from Pepperl+Fuchs for repairs are listed with their order numbers in the section "Spare parts".

For more information on service and spare parts, contact the service department at Pepperl+Fuchs.

8.3 Repairs to Ex-approved devices

When carrying out repairs to Ex-approved devices, please note the following:

- Repairs to Ex-approved devices may only be carried out by trained personnel or by Pepperl+Fuchs service.
- Comply with the prevailing standards, national Ex-area regulations, safety instructions (SI) and certificates.
- Only use original spare parts from Pepperl+Fuchs.
- When ordering a spare part, please note the device designation on the nameplate. Only replace parts with identical parts.
- Carry out repairs according to the instructions. On completion of repairs, carry out the specified routine test on the device.
- Only Pepperl+Fuchs service may convert a certified device into a different certified variant.
- Document all repair work and conversions.

8.4 Replacement

After a complete instrument or electronic module has been replaced, the parameters can be downloaded into the instrument again via the communication interface.

Prerequisite to this is that the data were uploaded to the PC beforehand using the **PACT_{ware}**TM. Measurement can continue without having to carry out a new setup. Only a linearisation and a tank map (interference echo suppression) have to be recorded again.

8.5 Spare parts (housing type F12)



Caution!

Only identical, original Pepperl+Fuchs spare parts may be used. The instrument may only be maintained and repaired by qualified personnel. The device documentation, applicable standards and legal requirements as well as any certificates have to be observed!

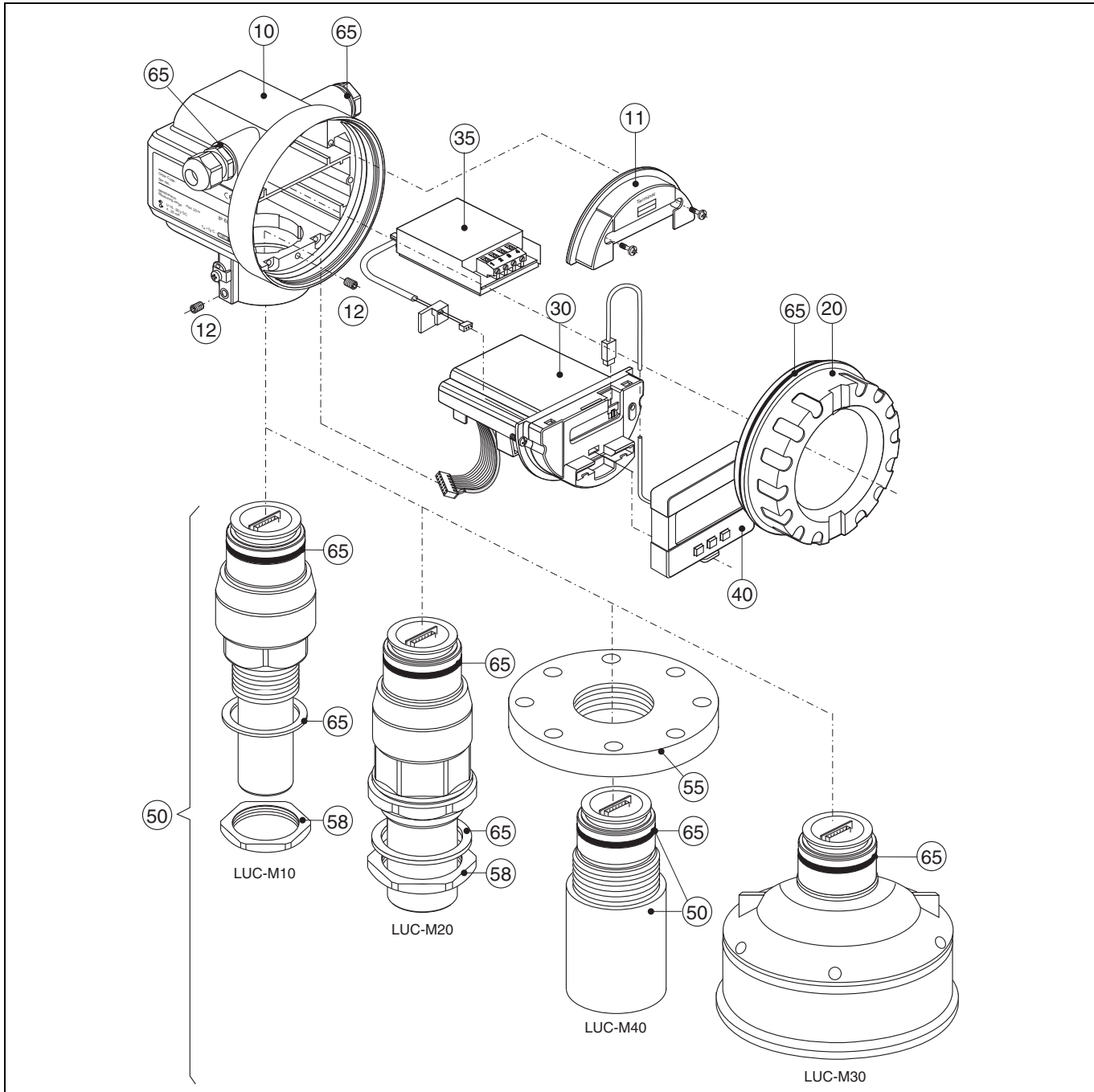

10 – Housing

- Housing F12, aluminium, G $\frac{1}{2}$
- Housing F12, aluminium, $\frac{1}{2}$ NPT
- Housing F12, aluminium, M20
- Housing F12, aluminium, M20, PA connector
- Housing F12, aluminium, coated, M20, 4-wire
- Housing F12, aluminium, coated, M20, metal
- Housing F12, aluminium, coated, G $\frac{1}{2}$, 4-wire
- Housing F12, aluminium, coated, $\frac{1}{2}$ NPT, 4-wire

11 – Hood for terminal compartment

Cover for the connection compartment F12
Cover for the connection compartment F12, remote display and operation

12 – Set of screws

Set of screws for housing F12/T12

20 – Cover

Cover F12/T12 aluminium, inspection glass, seal
Cover F12/T12 aluminium, coated, seal

30 – Electronics

Electronics LUC-M**, Ex, 2-wire, HART
Electronics LUC-M**, Ex, 4-wire, HART
Electronics LUC-M**, Ex, PA, V2.04

35 – Terminal module/power unit

Terminal module 4-pin, HART, 2-wire with connecting cable
Terminal module 4-pin, PROFIBUS PA
Power unit, 10.5 ... 32V DC (housing F12) for electronics, 4-wire
Power unit, 90 ... 250V AC (housing F12) for electronics, 4-wire
Power unit, CSA, 10.5 ... 32V DC (housing F12) for electronics, 4-wire
Power unit, CSA, 90 ... 250V AC (housing F12) for electronics, 4-wire

40 – Display

Display/operating module LUC-Z15

50 – Probe with process connection

Sensor LUC-M10 G1½
Sensor LUC-M10 1½ NPT
Sensor LUC-M20 G2
Sensor LUC-M20 2 NPT
Sensor LUC-M40
Sensor LUC-M30, 4", gasket

55 – Flanges

Flange, Uni-DN80/ANSI 3"/JIS 80A, PP
Flange, Uni-DN80/ANSI 3"/JIS 80A, PVDF
Flange, Uni-DN80/ANSI 3"/JIS 80A, 316L (1.4435)
Flange, Uni-DN100/ANSI 4"/JIS 100A, PP
Flange, Uni-DN100/ANSI 4"/JIS 100A, PVDF

58 – Hexagon nut

Hexagon nut (AF60) G1½, black, PC
Hexagon nut (AF70) G2, black, PC

65 – Sealing kit

Sealing kit LUC-M**

Miscellaneous

Nameplate LUC-M**, modification



Caution!

We are obliged to point out that each time devices with Ex certification have been repaired (replacement of assembly groups), the original condition has to be restored and another device check has to be carried out by authorised personnel.

Spare parts for remote display and operation

Adaption kit housing F12, 2-wire
Adaption kit housing F12, 4-wire
Cable, 20 m

25 – Cover for the connection compartment

Cover T12, aluminium, coated, seal

30 – Electronics

Electronics LUC-M**, Ex, 2-wire, HART
Electronics LUC-M**, Ex, PA, PROFIBUS PA

35 – Terminal module/power unit

Terminal module Ex d, 4-pin, 2-wire, HART
Terminal module Ex d, 2-pin, 2-wire, PROFIBUS PA
Terminal module EEx ia, 4-pin, HART, OVP
Terminal module EEx ia, 4-pin, PROFIBUS PA, OVP

40 – Display

Display/operating module LUC-Z15

50 – Probe with process connection

Sensor LUC-M10 G1½
Sensor LUC-M10 1½ NPT
Sensor LUC-M20 G2
Sensor LUC-M20 2 NPT
Sensor LUC-M40

55 – Flanges

Flange, Uni-DN80/ANSI 3"/JIS 80A, PP
Flange, Uni-DN80/ANSI 3"/JIS 80A, PVDF
Flange, Uni-DN80/ANSI 3"/JIS 80A, 316L (1.4435)
Flange, Uni-DN100/ANSI 4"/JIS 100A, PP
Flange, Uni-DN100/ANSI 4"/JIS 100A, PVDF
Flange, Uni-DN100/ANSI 4"/JIS 100A, 316L (1.4435)

58 – Hexagon nut

Hexagon nut (AF60) G1½, black, PC
Hexagon nut (AF70) G2, black, PC

65 – Sealing kit

Sealing kit LUC-M**

Miscellaneous

Nameplate LUC-M**, modification



Caution!

We are obliged to point out that each time devices with Ex certification have been repaired (replacement of assembly groups), the original condition has to be restored and another device check has to be carried out by authorised personnel.

8.7 Return

The following procedures must be carried out before a transmitter is sent to Pepperl+Fuchs e. g. for repair or calibration:

- Remove all residue which may be present. Pay special attention to the gasket grooves and crevices where fluid may be present. This is especially important if the fluid is dangerous to health, e. g. corrosive, poisonous, carcinogenic, radioactive, etc.
- Always enclose a duly completed "Declaration of contamination" form (a copy of the "Declaration of contamination" is included at the end of this operating manual). Only then can Pepperl+Fuchs transport, examine and repair a returned device.
- Enclose special handling instructions if necessary, for example a safety data sheet as per EN 91/155/EEC.

Additionally specify:

- The chemical and physical characteristics of the product.
- An exact description of the application.
- A short description of the error that occurred (specify error code if possible)
- Operating time of the device.

8.8 Disposal

In case of disposal please separate the different components according to their material consistence.

8.9 Software history

Software version/date	Changes to software	Changes to documentation
V 01.02.00/01.2002 V 01.02.02/03.2003	Original software. Compatible with: - PACT_{ware} TM - HART communicator 375 (from OS 4.6) with Rev. 1, DD 1.	
V 01.02.04/02.2004	LUC-M40 added Compatible with: - HART communicator 375 with Rev. 1, DD 1	LUC-M40 added
V 01.04.00/07.2006	Function "Detection window" added Compatible with: - PACT_{ware} TM - HART communicator 375 with Rev. 1, DD 1	"Detection window" added version: 07.06

8.10 Contact addresses of Pepperl+Fuchs

The addresses of Pepperl+Fuchs are given on the back cover of this operating manual. If you have any questions, please do not hesitate to contact your Pepperl+Fuchs representative.

9 Accessories

9.1 Weather protection cover

A weather protection cover made of stainless steel is recommended for outdoor mounting (LUC-Z16). The shipment includes the protective cover and tension clamp.

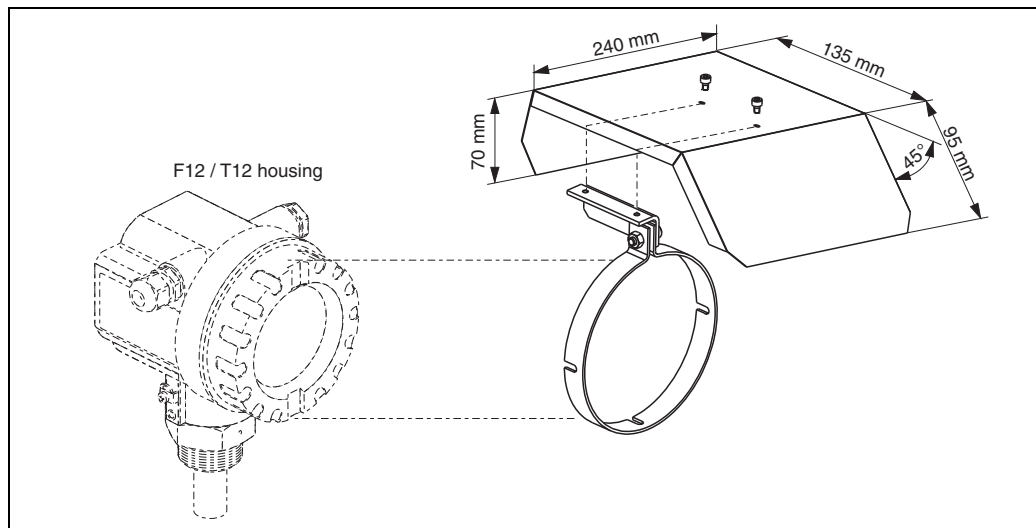

9.2 Mounting bracket for LUC-M10/LUC-M20

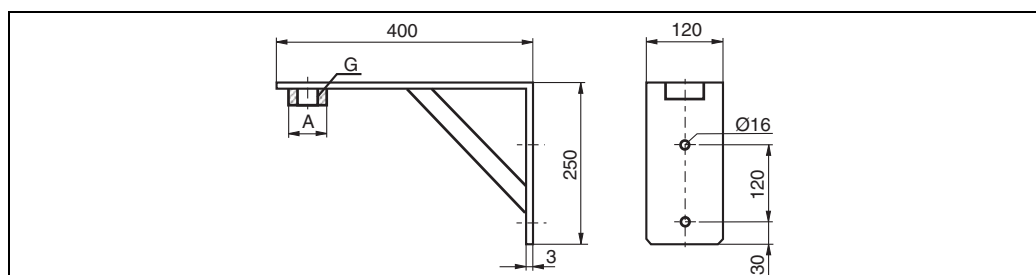

For sensor	Material	Order code
LUC-M10-G5***-***-** (G1½)	stainless steel 1.4301 (304)	LUC-Z18
LUC-M20-G6***-***-** (G2)	stainless steel 1.4301 (304)	LUC-Z19

Suited for NPT 1½" and 2" as well.

9.3 Mounting bracket for LUC-M30/LUC-M40

Mounting bracket for LUC-M30/LUC-M40 (LUC-Z17) mounting.

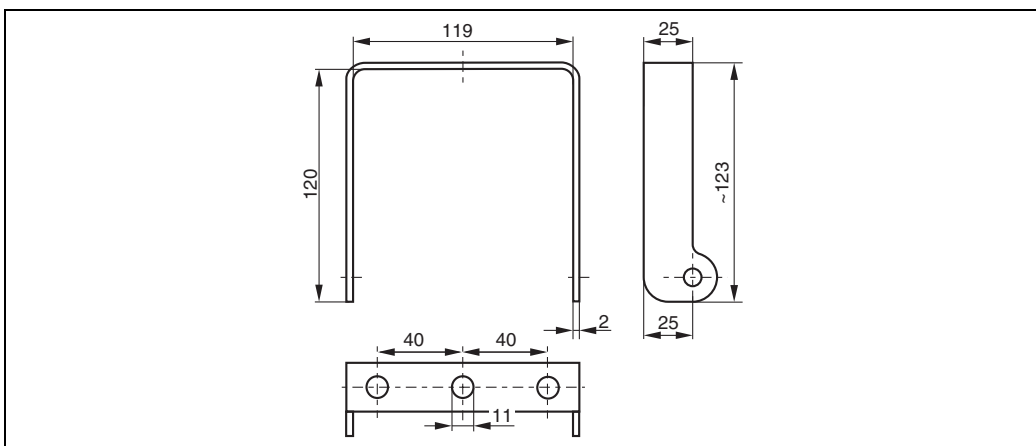

9.4 Cantilever

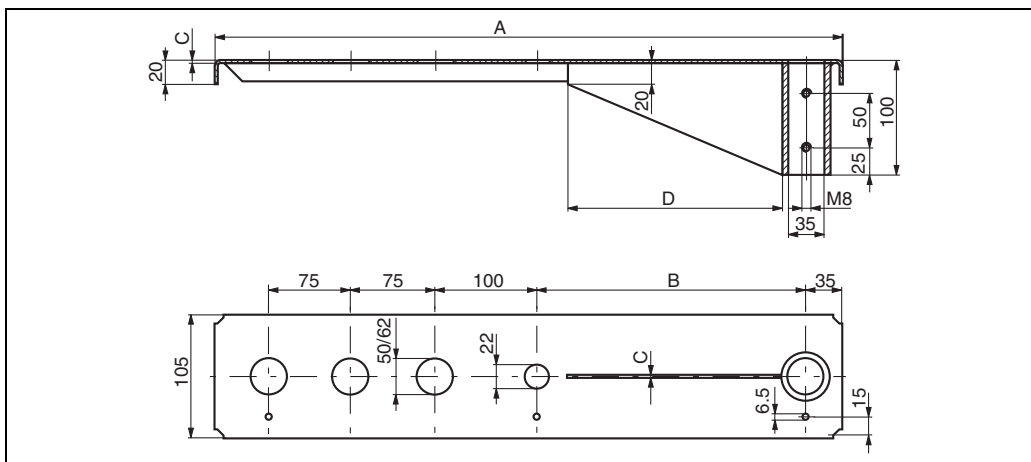

A	B	C	D	For sensor	Material	Order code
585 mm	250 mm	2 mm	200 mm	LUC-M10	stainless steel 1.4571 (316Ti)	LUC-Z20
					galv. steel	LUC-Z21
				LUC-M20	stainless steel 1.4571 (316Ti)	LUC-Z22
					galv. steel	LUC-Z23
1085 mm	750 mm	3 mm	300 mm	LUC-M10	stainless steel 1.4571 (316Ti)	LUC-Z24
					galv. steel	LUC-Z25
				LUC-M20	stainless steel 1.4571 (316Ti)	LUC-Z26
					galv. steel	LUC-Z27

- The 50 mm or 62 mm orifices serve for the mounting of the LUC-M10 or LUC-M20 sensor, respectively.
- The 22 mm orifice may be used for an additional sensor.

For the assembly of the cantilever can be used:

- a mounting frame, see page 51
- a wall bracket, see page 51

9.5 Operating and display module LUC-Z15

LCD display for on-site operation of the LUC-M** (LUC-Z15)

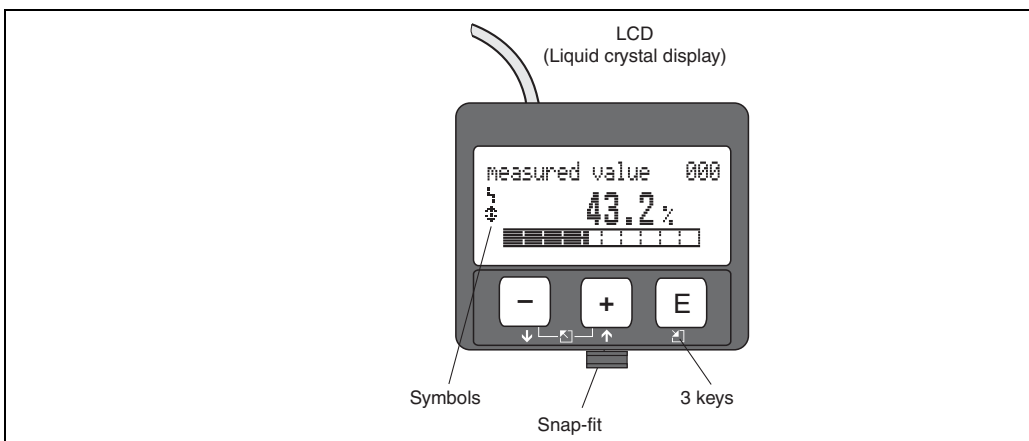

9.6 Mounting frame for cantilever

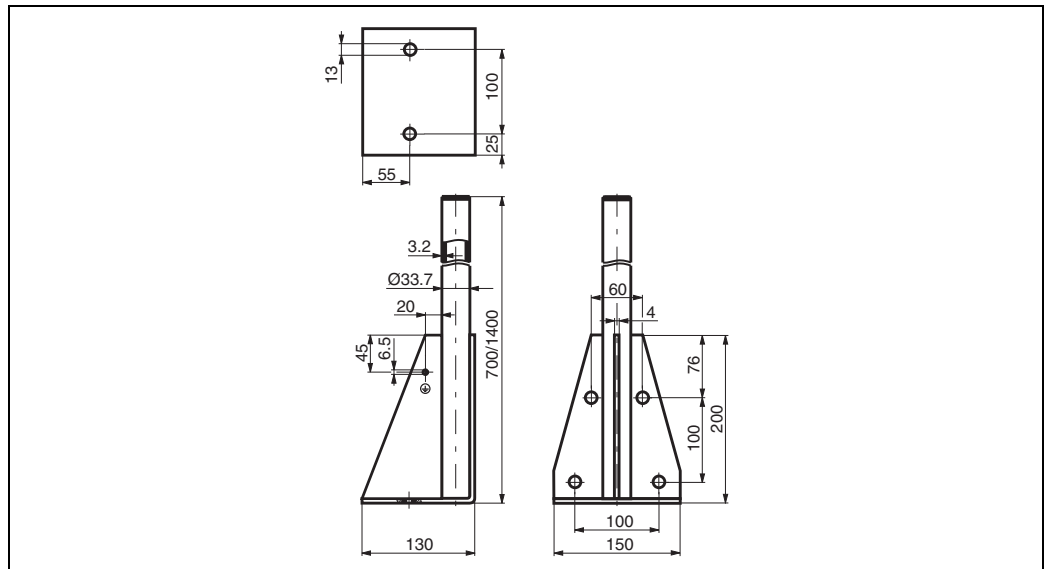

Height	Material	Order code
700 mm	galv. steel	LUC-Z30
700 mm	stainless steel 1.4571 (316Ti)	LUC-Z31
1400 mm	galv. steel	LUC-Z32
1400 mm	stainless steel 1.4571 (316Ti)	LUC-Z33

9.7 Wall bracket for cantilever

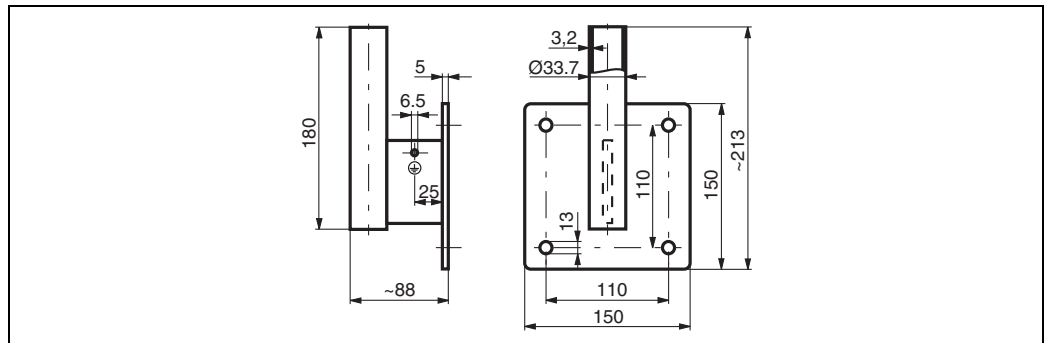

Order code	Material
LUC-Z50	galv. steel
LUC-Z51	stainless steel 1.4571 (316Ti)

9.8 Adapter flange for LUC-M10/LUC-M20

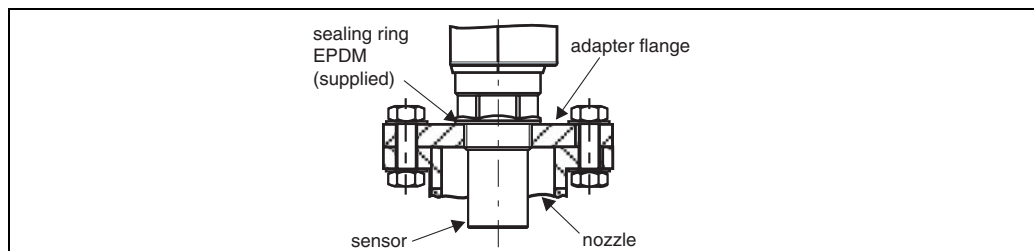

9.8.1 Version with metrical thread

		Process gland	
	F73	DN50 PN16	
	F93	DN80 PN16	
	FA3	DN100 PN16	
	XXX	further process glands	
		Sensor gland	
	G5	G1½, ISO 228	
	G6	G2, ISO 228	
		Material	
	S	stainless steel 1.4435 (316L)	
	P	PPS (Polypropylen)	
LUC-Z-			product designation

9.8.2 Version with conical thread

		Process gland	
	A61	ANSI 2", 150 psi	
	A81	ANSI 3", 150 psi	
	A91	ANSI 4", 150 psi	
	XXX	further process glands	
		Sensor gland	
	N5	1½ NPT	
	N6	2 NPT	
		Material	
	S	stainless steel 1.4435 (316L)	
	P	PPS (Polypropylen)	
LUC-Z-			product designation

9.9 Universal slip-on flange for LUC-M30

	Process gland	
FA3	DN100 PN16	
A91	ANSI 4", 150 psi	
J20	JIS16K100	
	Material	
P	PPS (Polypropylen), max. 1.5 bar abs.	
L	steel, varnished	
S	stainless steel 1.4571 (316Ti)	
LUC-Z-		product designation

9.10 Remote display and operation

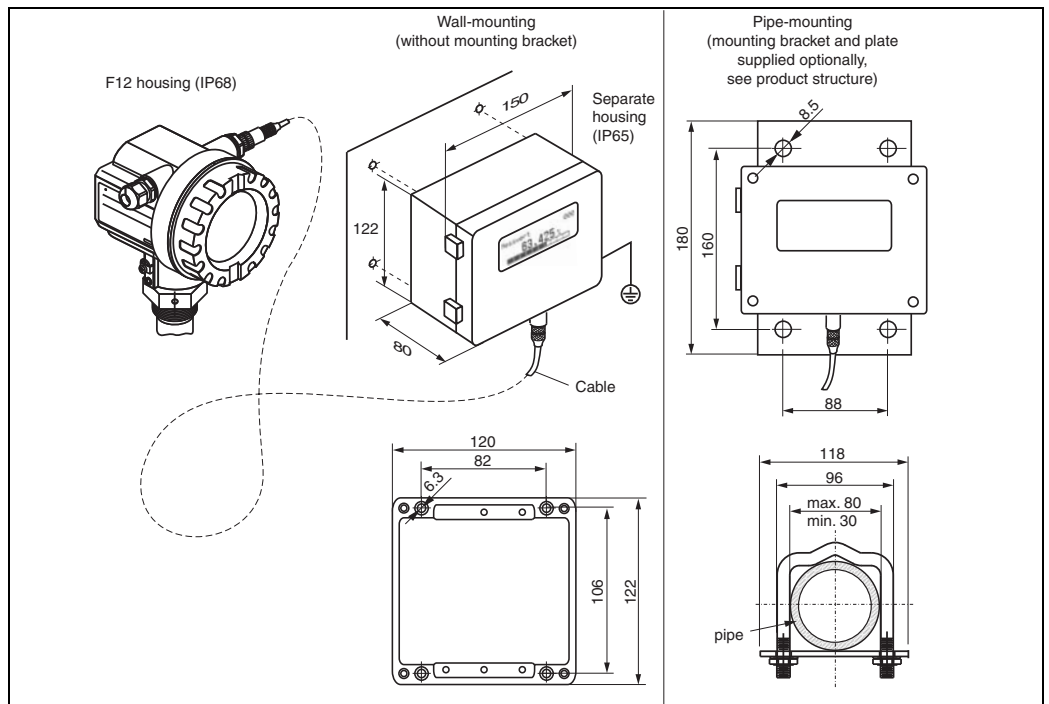

Technical data:

max. cable length	20 m, 65 ft (fixed length with connection plug)
temperature range	-30 °C...+70 °C (243 K ... 343 K)
degree of protection	housing IP65/67, cable IP68 acc. to EN 60529
material	housing: alloy of aluminium ALSi12 cabel gland: brass, nickel-plated
dimensions (H x B x T)	122 mm x 150 mm x 80 mm

Version	Order code
remote display with on-site operation, 20 m cable	LUC-Z40-NA1A
remote display with on-site operation, 20 m cable, with mounting bracket 2"	LUC-Z40-NA1B
remote display with on-site operation, 20 m cable, 2G EEx ia, 3D	LUC-Z40-EX1A
remote display with on-site operation, 20 m cable, with mounting bracket 2", 2G EEx ia, 3D	LUC-Z40-EX1B

10 Technical data

10.1 Input

Measured variable The distance D between the sensor membrane and the product surface is measured. Using the linearisation function, the device uses D to calculate:

- level L in any units
- volume V in any units
- flow Q across measuring weirs or open channels in any units

Maximum range/ blocking distance

Sensor	BD	Max. range in liquids	Max. range in solids
LUC-M10	0.25 m	5 m	2 m
LUC-M20	0.35 m	8 m	3.5 m
LUC-M30	0.6 m	15 m	7 m
LUC-M40	0.4 m	10 m	5 m

The actual range is dependent on the measuring conditions. Refer to technical information TI 365O/98/en for an estimation.

10.2 Output

Output signal 4 mA ... 20 mA with HART protocol

- Signal on alarm**
- Error symbol, error code and plain text description on the on-site display
 - Error code via HART communication
 - Current output (configurable)

10.3 Auxiliary energy

Terminals Cable cross-section: 0.5 mm² ... 2.5 mm² (20 ... 14 AWG)

- Cable entry**
- Cable gland M20 x 1.5 (recommended cable diameter 6 mm ... 10 mm)
 - Cable entry G½ or ½ NPT

- Supply voltage**
- 2-wire HART, loop powered: 14 V ... 36 V (depending on output current)
 - 2-wire fixed current, loop powered: 10 V ... 36 V
 - 4-wire DC: 10.5 VDC ... 32 VDC
 - 4-wire AC: 90 VAC ... 253 VAC

There may be additional restrictions for devices with an explosion protection certificate. Refer to the notes in the appropriate safety instructions (SI).

Power consumption

Version	Power consumption
2-wire	51 mW ... 800 mW
4-wire AC	max. 4 VA
4-wire DC; LUC-M10/20	330 mW ... 830 mW
4-wire DC; LUC-M30/40	600 mW ... 1 W

Load HART min. load for HART communication: 250 Ω

HART ripple 47 Hz ... 125 Hz: $V_{pp} = 200 \text{ mV}$ (measured at 500 Ω)

Max. noise HART 500 Hz ... 10 kHz: $V_{rms} = 2.2 \text{ mV}$ (measured at 500 Ω)

Galvanic isolation With 4-wire devices, the evaluation electronics and mains voltage are galvanically isolated from each other.

10.4 Performance characteristics

Reaction time The reaction time depends on the parameter settings

- 2-wire devices (LUC-M10/LUC-M20/LUC-M40): min. 2 s
- 4-wire devices (LUC-M10/LUC-M20/LUC-M40): min. 0.5 s

Reference operating conditions

- temperature = +20 °C (293 K)
- pressure = 1013 mbar abs.
- humidity = 50 %
- ideal reflective surface (e. g. calm, smooth fluid surface)
- no interference reflections within signal beam
- set application parameters:
 - tank shape = flat ceiling
 - medium property = liquid
 - process conditions = calm surface

Measured value resolution

Sensor	Measured value resolution
LUC-M10	1 mm
LUC-M20	1 mm
LUC-M30	2 mm
LUC-M40	2 mm

Measuring error Typical specifications for reference operating conditions (include linearity, repeatability, and hysteresis):

Sensor	Measuring error
LUC-M10	$\pm 2 \text{ mm}$ or 0.2 % of set measuring range (empty calibration) ¹
LUC-M20	$\pm 2 \text{ mm}$ or 0.2 % of set measuring range (empty calibration) ¹
LUC-M30	$\pm 4 \text{ mm}$ or 0.2 % of set measuring range (empty calibration) ¹
LUC-M40	$\pm 4 \text{ mm}$ or 0.2 % of set measuring range (empty calibration) ¹

¹whichever is greater.

Influence of the vapor pressure The vapor pressure at 20 °C (293 K) gives a hint on the accuracy of the ultrasonic level measurement. If the vapor pressure at 20 °C (293 K) is below 50 mbar, ultrasonic level measurement is possible with a very high accuracy. This is valid for water, aqueous solutions, water-solid-solutions, dilute acids (hydrochloric acid, sulfuric acid, ...), dilute bases (caustic soda, ...), oils, greases, slurries, pastes, ...

High vapor pressures or outgassing media (ethanol, acetone, ammonia, ...) can influence the accuracy. If conditions like these are present, please contact the Pepperl+Fuchs support.

10.5 Ambient conditions

Ambient temperature -40 °C ... +80 °C (233 K ... 353 K)

The functionality of the LC display becomes restricted at $T_u < -20$ °C (253 K) and $T_u > +60$ °C (333 K).

If the device is operated outdoors in strong sunlight, you should use a protective cover.

Storage temperature -40 °C ... +80 °C (233 K ... 353 K)

Climate class EN 60068-2-38 (test Z/AD) DIN/IEC 68 T2-30Db

- Protection degree**
- with closed housing, tested according to
 - IP68, NEMA 6P (24h at 1.83 m under water surface)
 - IP66, NEMA 4x
 - with open housing: IP20, NEMA 1 (also ingress protection of the display)

Vibration resistance EN 60068-2-64/IEC 68-2-64: 20 Hz ... 2000 Hz, 1 (m/s²)/Hz; 3 x 100 min

- Electromagnetic compatibility (EMC)**
- Interference emission to EN 61326, Equipment Class B
 - Interference immunity to EN 61326, Appendix A (Industrial) and NAMUR Recommendation NE 21 (EMC).
 - A standard installation cable is sufficient if only the analogue signal is used. Use a screened cable when working with a superimposed communication signal (HART).

10.6 Process conditions

Process temperature -40°C ... +80°C (233 K ... 353 K)

A temperature sensor is integrated in the sensor for temperature-dependent time-of-flight correction.

- Process pressure**
- LUC-M10/LUC-M20: 0.7 bar ... 3 bar abs.
 - LUC-M30/LUC-M40: 0.7 bar ... 2.5 bar abs.

11 Appendix

11.1 Operating menu

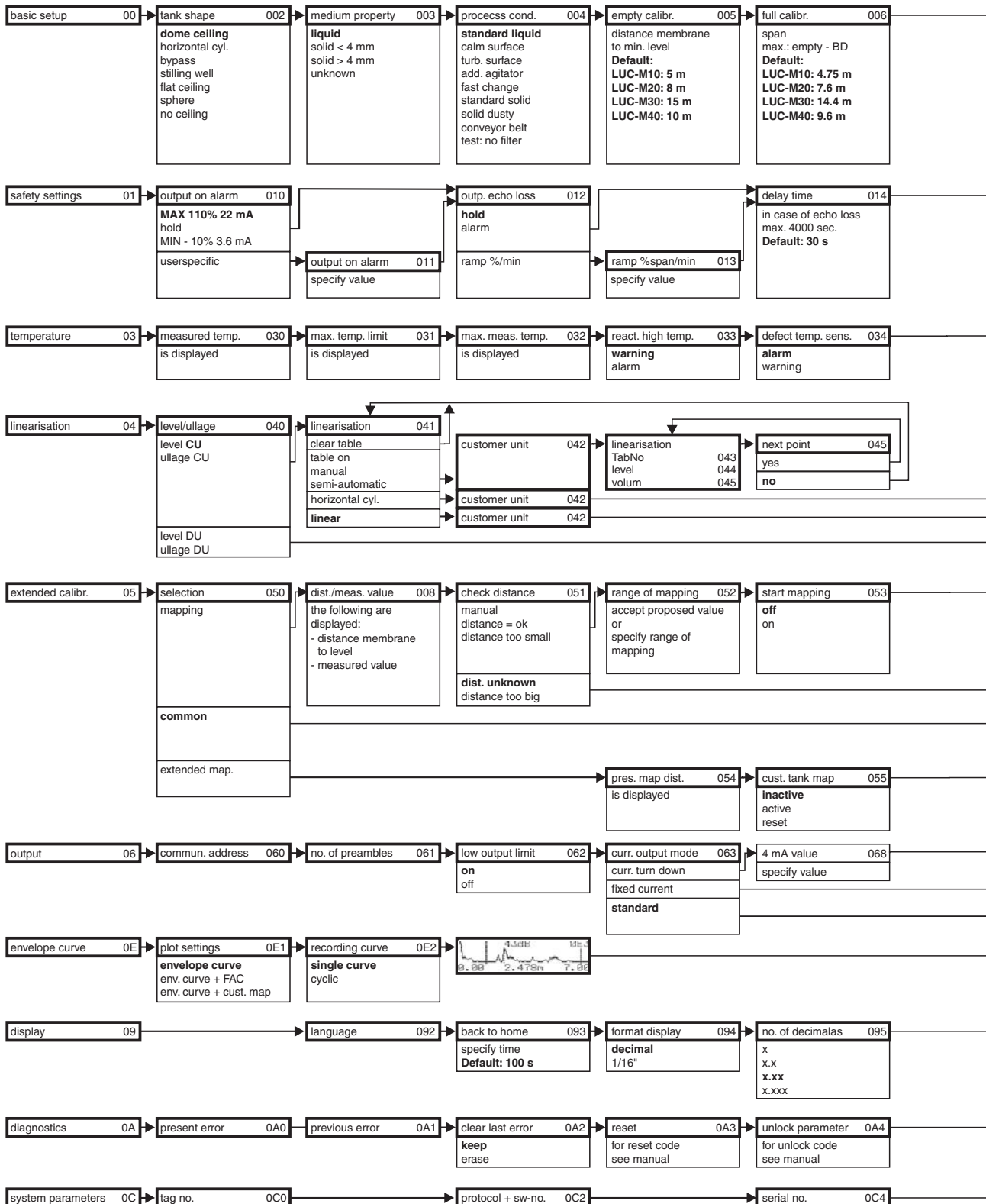

Note: The default values of the parameters are typed in bold face.

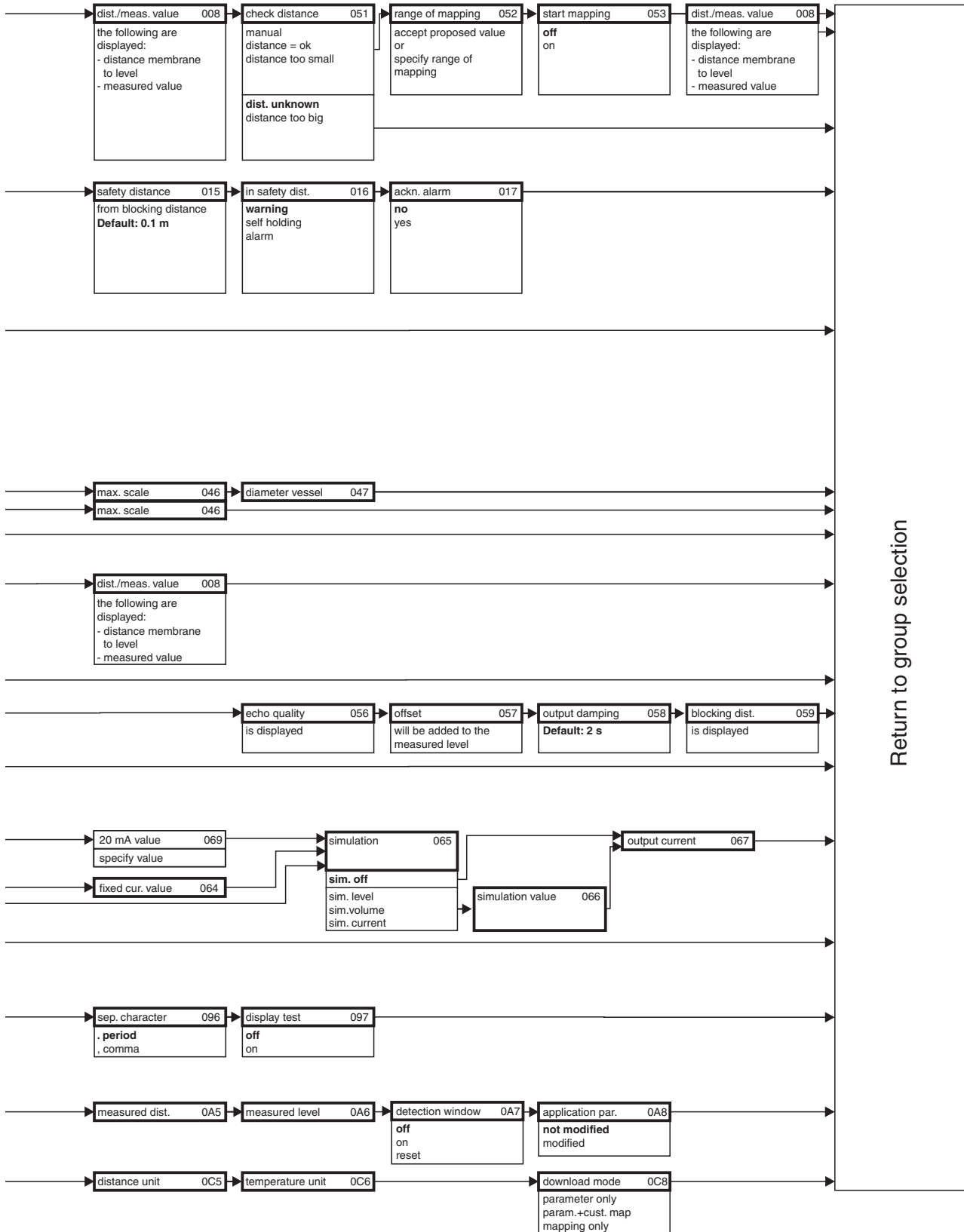

DOCT-0821C 01/2010 185564

11.2 Measuring principle

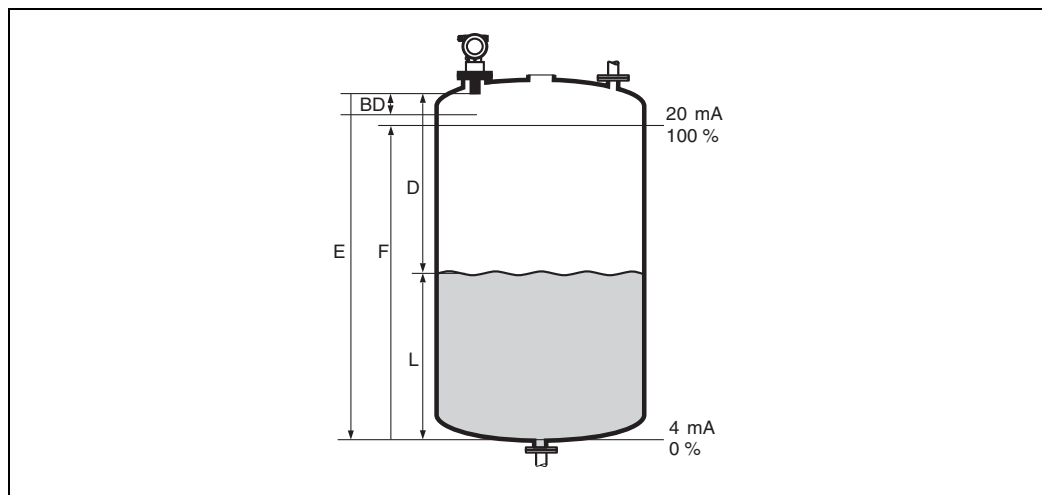

E: Empty distance; **F:** Span (full distance); **D:** Distance from sensor membrane - product surface; **L:** Level; **BD:** Blocking distance

Sensor	BD	Max. range fluids	Max. range bulk materials
LUC-M10	0.25 m	5 m	2 m
LUC-M20	0.35 m	8 m	3.5 m
LUC-M30	0.6 m	15 m	7 m
LUC-M40	0.4 m	10 m	5 m

11.2.1 Time-of-flight method

The sensor of the LUC-M** transmits ultrasonic pulses in the direction of the product surface. There, they are reflected back and received by the sensor. The LUC-M** measures the time t between pulse transmission and reception. The instrument uses the time t (and the velocity of sound c) to calculate the distance D between the sensor membrane and the product surface:

$$D = c \times t/2$$

As the device knows the empty distance E from a user entry, it can calculate the level as follows:

$$L = E - D$$

An integrated temperature sensor compensates for changes in the velocity of sound caused by temperature changes.

11.2.2 Interference echo suppression

The interference echo suppression feature on the LUC-M** ensures that interference echos (e. g. from edges, welded joints and installations) are not interpreted as a level echo.

11.2.3 Calibration

Enter the empty distance E and the span F to calibrate the device.

11.2.4 Blocking distance

Span F may not extend into the blocking distance BD . Level echos from the blocking distance cannot be evaluated due to the transient characteristics of the sensor.

A		N	
Accessories	49	Nameplate	6
Adapter flange	52	Nozzle	17
Alarm	40	O	
Application errors	42	On-site display	28
B		Operating and display module	24, 50
Blocking distance	17, 35	Operating menu	58
C		Operational safety	4
Cantilever	50	P	
CE mark	9	PACT^{ware}™	27, 29, 48
Current error	40	Plot settings	37
D		Process conditions	33
Declaration of conformity	9	Protection degree	56
Declaration of contamination	62	R	
Designated use	4	Range	18
Dimensions	10	Remote display and operation	53
Display appearance	24	Repairs to Ex-approved devices	43
Display symbols	25	Reset	30
E		Return	48
Electrical connection	20	S	
Envelope curve display	38	Safety distance	18
Empty calibration	35	Safety instructions	4
Error codes	41	Safety symbols	5
Error types	40	Shafts	15
Exterior cleaning	43	Software history	48
F		Software security locking	30
Flow measurements	15	Spare parts	44
Full calibration	35	System error messages	40
H		T	
Handheld terminal	27, 29	Tank shape	33
Hardware security locking	30	Technical data	54
HART	22, 27, 29	Terminal assignment	21
HART communicator	27, 29	Triangular weir	16
HART modem	27	U	
Hazardous area	4	Universal slip-on flange	53
I		Unlock parameter	30
Installation variants	12	W	
Interference echo suppression	36	Wall bracket	51
K		Warning	40
Key assignment	25	Weather protection cover	49
Khafagi-Venturi flume	15		
L			
Level measurements	14		
M			
Maintenance	43		
Measuring principle	60		
Measuring range	17		
Medium property	33		
Menu structure	58		
Mounting	14		
Mounting bracket	11, 49		
Mounting frame	51		

Because of legal regulations and for the safety of our employees and operating equipment, we need the "Declaration of Hazardous Material and De-Contamination", with your signature, before your order can be handled. Please make absolutely sure to attach it to the outside of the packaging.

Aufgrund der gesetzlichen Vorschriften und zum Schutz unserer Mitarbeiter und Betriebseinrichtungen, benötigen wir die unterschriebene „Erklärung zur Kontamination und Reinigung“, bevor Ihr Auftrag bearbeitet werden kann. Bringen Sie diese unbedingt außen an der Verpackung an.

Type of instrument/sensor _____ **Serial number** _____
Geräte-/Sensortyp _____ **Seriennummer** _____

Used as SIL device in a Safety Instrumented System/Einsatz als SIL-Gerät in Schutzeinrichtungen

Process data/ Temperature/*Temperatur* _____ [°F] _____ [°C] Pressure/*Druck* _____ [psi] _____ [Pa]
Prozessdaten Conductivity/*Leitfähigkeit* _____ [µS/cm] Viscosity/*Viskosität* _____ [cp] _____ [mm²/s]

Medium and warnings
Warnhinweise zum Medium



	Medium/concentration <i>Medium/Konzentration</i>	Identification <i>CAS No.</i>	flammable <i>entzündlich</i>	toxic <i>giftig</i>	corrosive <i>ätzend</i>	harmful/ irritant <i>gesundheitsschädlich/ reizend</i>	other * <i>sonstiges*</i>	harmless <i>unbedenklich</i>
Process medium <i>Medium im Prozess</i>								
Medium for process cleaning <i>Medium zur Prozessreinigung</i>								
Returned part cleaned with <i>Medium zur Endreinigung</i>								

* explosive; oxidising; dangerous for the environment; biological risk; radioactive
 * *explosiv; brandfördernd; umweltgefährlich; biogefährlich; radioaktiv*

Please tick should one of the above be applicable, include security sheet and, if necessary, special handling instructions.
Zutreffendes ankreuzen; trifft einer der Warnhinweise zu, Sicherheitsdatenblatt und ggf. spezielle Handhabungsvorschriften beilegen.

Description of failure/Fehlerbeschreibung _____

Company data/Angaben zum Absender

Company/ <i>Firma</i> _____	Contact person/ <i>Ansprechpartner</i> _____
Address/ <i>Adresse</i> _____	Phone number/ <i>Telefon-Nr.</i> _____
_____	Fax/ <i>E-Mail</i> _____
_____	Your order No./ <i>Ihre Auftragsnr.</i> _____

We hereby certify that this declaration is filled out truthfully and completely to the best of our knowledge. We further certify that the returned parts have been carefully cleaned. To the best of our knowledge they are free of any residues in dangerous quantities.
Wir bestätigen, die vorliegende Erklärung nach unserem besten Wissen wahrheitsgetreu und vollständig ausgefüllt zu haben. Wir bestätigen weiter, dass die zurückgesandten Teile sorgfältig gereinigt wurden und nach unserem besten Wissen frei von Rückständen in gefahrbringender Menge sind.

(Place, date/Ort, Datum)

Name, department/Abteilung (please print/bitte Druckschrift)

Signature/Unterschrift

With regard to the supply of products, the current issue of the following document is applicable: The General Terms of Delivery for Products and Services of the Electrical Industry, published by the Central Association of the "Elektrotechnik und Elektroindustrie (ZVEI) e.V." including the supplementary clause: "Erweiterter Eigentumsvorbehalt".

We at Pepperl+Fuchs recognise a duty to make a contribution to the future,
For this reason, this printed matter is produced on paper bleached without the use of chlorine.

PROCESS AUTOMATION – PROTECTING YOUR PROCESS



Worldwide Headquarters

Pepperl+Fuchs GmbH
68307 Mannheim · Germany
Tel. +49 621 776-0
E-mail: info@de.pepperl-fuchs.com

USA Headquarters

Pepperl+Fuchs Inc.
Twinsburg, Ohio 44087 · USA
Tel. +1 330 4253555
E-mail: sales@us.pepperl-fuchs.com

Asia Pacific Headquarters

Pepperl+Fuchs Pte Ltd.
Company Registration No. 199003130E
Singapore 139942
Tel. +65 67799091
E-mail: sales@sg.pepperl-fuchs.com

www.pepperl-fuchs.com

Subject to modifications
Copyright PEPPERL+FUCHS • Printed in Germany



52027986

BA2370/98/en/01.10
FM7.0

 **PEPPERL+FUCHS**
PROTECTING YOUR PROCESS

DOCT-0821C

185564
01/2010