

LB Remote I/O System Hardware

Manual



Your automation, our passion.

 **PEPPERL+FUCHS**

With regard to the supply of products, the current issue of the following document is applicable:
The General Terms of Delivery for Products and Services of the Electrical Industry, published
by the Central Association of the Electrical Industry (Zentralverband Elektrotechnik und Elek-
troindustrie (ZVEI) e.V.) in its most recent version as well as the supplementary clause:
"Expanded reservation of proprietorship"

Worldwide

Pepperl+Fuchs Group
Lilienthalstr. 200
68307 Mannheim
Germany
Phone: +49 621 776 - 0
E-mail: info@de.pepperl-fuchs.com

North American Headquarters

Pepperl+Fuchs Inc.
1600 Enterprise Parkway
Twinsburg, Ohio 44087
USA
Phone: +1 330 425-3555
E-mail: sales@us.pepperl-fuchs.com

Asia Headquarters

Pepperl+Fuchs Pte. Ltd.
P+F Building
18 Ayer Rajah Crescent
Singapore 139942
Phone: +65 6779-9091
E-mail: sales@sg.pepperl-fuchs.com
<https://www.pepperl-fuchs.com>

1	Introduction.....	5
1.1	Content of this Document.....	5
1.2	Target Group, Personnel	5
1.3	Symbols Used	6
2	Product Specifications.....	7
2.1	Prerequisites for Operating the Remote I/O Unit.....	7
2.2	Introduction.....	7
2.3	System Components	8
2.4	Backplanes.....	9
2.4.1	Function.....	9
2.4.2	Design and Dimensions.....	9
2.4.3	Backplane Combinations.....	12
2.4.4	Backplane and Module Compatibility	13
2.4.5	Scope of Delivery	13
2.5	I/O Modules, Gateways, Com Units, and Power Supplies.....	14
2.5.1	Function.....	14
2.5.2	Design and Dimensions.....	15
2.6	Accessories.....	16
2.6.1	Bus Connection for RS-485-based Fieldbusses	16
2.6.2	Field Wiring.....	17
2.6.3	Separation between Intrinsically Safe and Non-Intrinsically Safe I/O Modules	21
2.6.4	Switch Protection Cover LB9181	21
3	Installation.....	22
3.1	Surrounding Enclosure	22
3.2	Mounting the Backplane	22
3.3	Connections	22
3.3.1	Backplanes LB9022* to LB9029*(except LB9022S, LB9024S, LB9022BP22320.1, LB9024BP24300.1)23	
3.3.2	Backplanes LB9022S, LB9024S, LB9022BP22320.1, LB9024BP24300.1	27
3.3.3	LB9035A.....	31
3.4	Inserting and Removing Modules	35
3.5	Installing the Separation Wall.....	36
3.6	Field Wiring	39
3.7	Coding.....	41
3.8	Line Fault Detection.....	42
3.9	Cold Junctions in Thermocouples	43
3.10	Line Resistance in Resistance Thermometers	44
3.11	Strain Gauge Measurement.....	45

3.12	Status Monitoring of the Output Switch-off	46
3.13	Redundancy for PROFIBUS Communication	46
3.13.1	Basic Principles	46
3.13.2	Media Redundancy	47
3.13.3	Application Redundancy	47
3.14	Connection of RS-485-based Fieldbuses	48
3.14.1	Potential Equalization and Shielding	50
3.14.2	Wiring of the Signal Lines	50
3.14.3	Shielding and Earthing (Grounding)	51
3.14.3.1	Grounding of the Cable Shield with High-Quality Equipotential Bonding Between Safe and Hazardous Areas	53
3.14.3.2	Single-Sided Grounding of the Fieldbus Shield with Low-Quality Equipotential Bonding Between Safe and Hazardous Areas	55
3.14.3.3	Double-Sided Grounding of the Fieldbus Shield with Low-Quality Equipotential Bonding Between Safe and Hazardous Areas	57
3.14.3.4	Double-Sided Grounding of the Fieldbus Shield in Ethernet Bus Systems	58
3.14.4	System Expansion	59
3.15	Connection Ethernet-based Fieldbuses	59
4	Commissioning	62
4.1	Commissioning of RS 485 based Fieldbuses	62
4.1.1	Electrical Testing of Connections	62
4.1.2	Configuration	64
4.1.3	Startup Phase	65
4.2	Commissioning of Ethernet based Fieldbuses	65
5	Operation	66
6	Troubleshooting	67
6.1	Troubleshooting of RS 485 based fieldbuses	67
6.2	Troubleshooting of Ethernet based fieldbuses	68

1 Introduction

1.1 Content of this Document

This document contains information required to use the finished device or system in the relevant phases of the product life cycle. This may include information on the following:

- Product identification
- Delivery, transport, and storage
- Mounting and installation
- Commissioning and operation
- Maintenance and repair
- Troubleshooting
- Dismounting
- Disposal



Note

This document does not replace the instruction manuals for the components in use.

The safety information for the components in use determines the specific safety instructions that apply to the system. The instruction manuals for the components in use must have been read and understood.



Note

For complete information about the components in use, refer to the instruction manuals and further documentation available online at www.pepperl-fuchs.com.

The documentation comprises the following parts:

- This hardware manual
- Software manual for the gateways or com units in use
- Instruction manuals for the components in use
- Datasheets for the components in use

In addition, the documentation may comprise the following parts, if applicable:

- EC-type-examination certificate
- EU declaration of conformity
- Attestation of conformity
- Certificates
- Control drawings
- Other documents

1.2 Target Group, Personnel

Responsibility for planning, assembly, commissioning, operation, maintenance, and dismantling lies with the plant operator.

Only appropriately trained and qualified personnel may carry out mounting, installation, commissioning, operation, maintenance, and dismantling of the product. The personnel must have read and understood the instruction manual and the further documentation.

Ensure that you are familiar with the system and its components before use. Read the documentation carefully.

1.3 Symbols Used

This document contains symbols for the identification of warning messages and of informative messages.

Warning Messages

You will find warning messages, whenever dangers may arise from your actions. It is mandatory that you observe these warning messages for your personal safety and in order to avoid property damage.

Depending on the risk level, the warning messages are displayed in descending order as follows:



Danger!

This symbol indicates an imminent danger.

Non-observance will result in personal injury or death.



Warning!

This symbol indicates a possible fault or danger.

Non-observance may cause personal injury or serious property damage.



Caution!

This symbol indicates a possible fault.

Non-observance could interrupt the device and any connected systems and plants, or result in their complete failure.

Informative Symbols



Note

This symbol brings important information to your attention.



Action

1. This symbol indicates a paragraph with instructions. You are prompted to perform an action or a sequence of actions.

2 Product Specifications

2.1 Prerequisites for Operating the Remote I/O Unit



Note

Requirements for Equipment Protection Level Gc

The LB remote I/O system must only be installed and operated if installed in a surrounding enclosure

- that complies with the requirements for surrounding enclosures in accordance with IEC/EN 60079-0 and that
 - is designed with IP54 protection in accordance with IEC/EN 60529.
-



Note

Requirements for Non-Hazardous Areas

The LB remote I/O system must only be installed and operated if installed in a surrounding enclosure

- that complies with the requirements for surrounding enclosures in accordance with IEC/EN 60079-0 and that
- is designed with IP54 protection in accordance with IEC/EN 60529.

Alternatively, installation and operation of the system is permitted in a controlled environment where pollution degree 2 in accordance with IEC/EN 60664-1 is ensured.

2.2 Introduction

Remote I/O stations are signal modification devices that act as an interface for signals between field devices and process control systems. The individual components, i.e., the I/O modules, gateway resp. com units, and power supplies, are plugged into the slots on the backplane. Gateway resp. com units are available for various standard buses and form the interface between the I/O modules and the process control system. Power supplies are used to power the gateway resp. com units and I/O modules.

The bus systems detailed below are supported.

Bus system	Gateway/Com unit
PROFINET	LB8122A.1.EL
PROFIBUS DP/DP-V1	LB8106*, LB8109*
MODBUS RTU	LB8107*
MODBUS TCP	LB8111*
FOUNDATION fieldbus H1	LB8110*

This manual sets out how to work with the hardware. For information on how to configure the gateway resp. com units and I/O modules, refer to the software manual for the relevant gateway resp. com unit in use.

2.3 System Components

System Overview

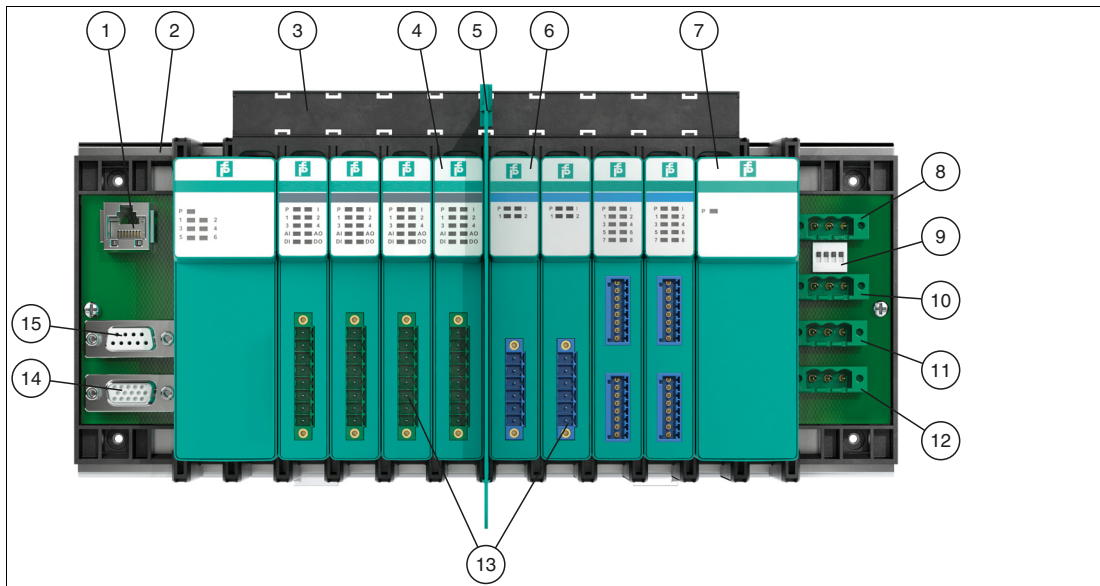

Figure 2.1 LB remote I/O system components

- 1 Fieldbus Connection
- 2 Backplane
- 3 Label carrier
- 4 I/O module
- 5 Separation wall
- 6 I/O modules with intrinsically safe circuits
- 7 Power supply
- 8 Booster connection
Connection for a 24 VDC auxiliary energy for 4-channel digital outputs LB6*10* ...
LB6*15*
- 9 Function switch
- 10 Bus-independent deactivation of the I/O modules
- 11 Redundant 24 V power supply
- 12 24 V power supply
- 13 Field connections
- 14 Extension connection
- 15 Service bus connection

2.4 Backplanes

2.4.1 Function

Backplanes are used to hold gateways resp. com units, power supplies, and I/O modules. Fixed slots are reserved on the backplane for gateways resp. com units and power supplies. Slots for I/O modules have equal status, meaning functions can be arranged side by side as required.

2.4.2 Design and Dimensions

LB9022BP22320.1

- Base backplane with slots for redundant com units
- Slots for max. 22 single-width or 11 dual-width I/O modules
- Version with bus-independent deactivation of the I/O modules is available

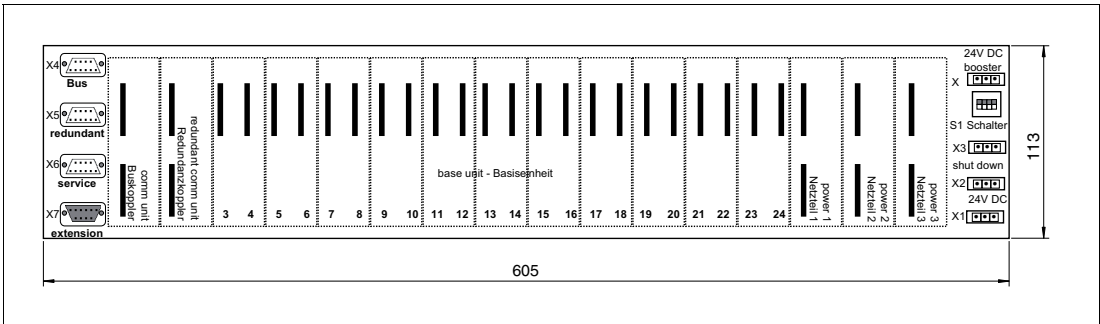

Figure 2.2 Dimensions of the LB9022BP22320.1

LB9023BP08110.1

- Base backplane
- Slots for max. 8 single-width or 4 dual-width I/O modules

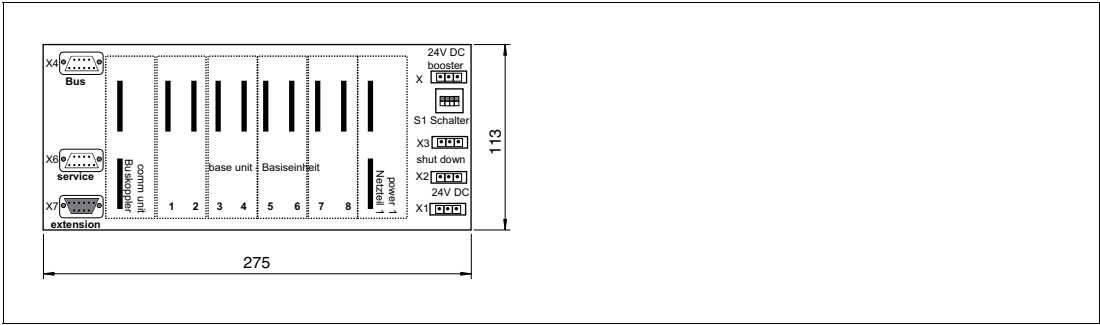

Figure 2.3 Dimensions of the LB9023BP08110.1

LB9024BP24300.1

- Extension backplane
- Slots for max. 24 single-width or 12 dual-width I/O modules
- Bus-independent deactivation of the I/O modules

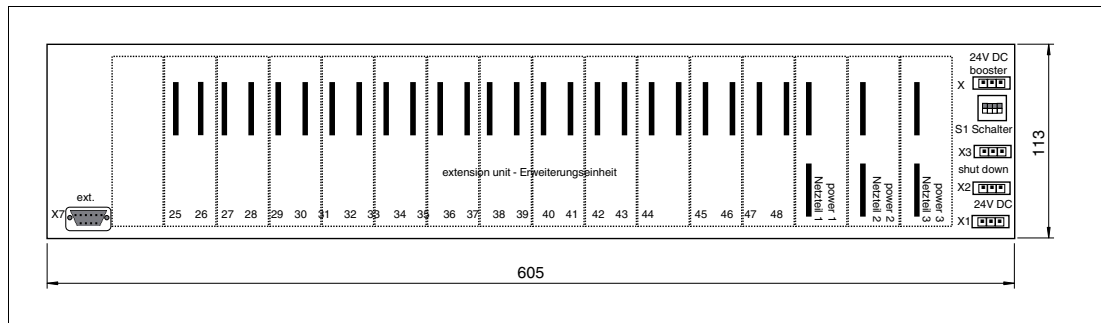

Figure 2.4 Dimensions of the LB9024BP24300.1

LB9025BP08100.1

- Extension backplane
- Slots for max. 8 single-width or 4 dual-width I/O modules

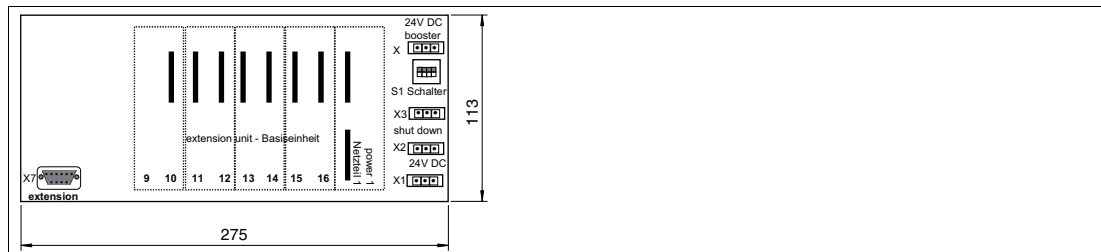

Figure 2.5 Dimensions of the LB9025BP08100.1

LB9026BP16210.1

- Base backplane
- Slots for max. 16 single-width or 8 dual-width I/O modules

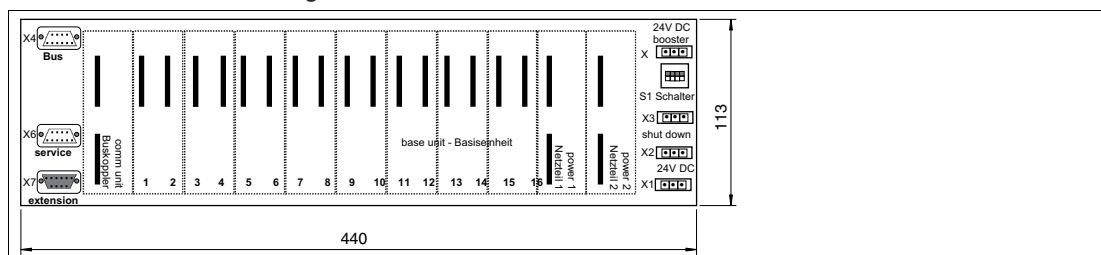

Figure 2.6 Dimensions of the LB9026BP16210.1

LB9027BP16200.1

- Extension backplane
- Slots for max. 16 single-width or 8 dual-width I/O modules

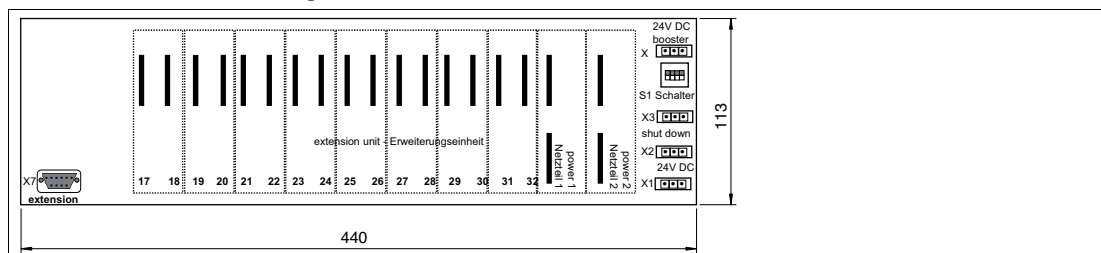

Figure 2.7 Dimensions of the LB9027BP16200.1

LB9029BP12320.1

- Base backplane with slots for redundant com units
- Slots for max. 12 single-width or 6 dual-width I/O modules

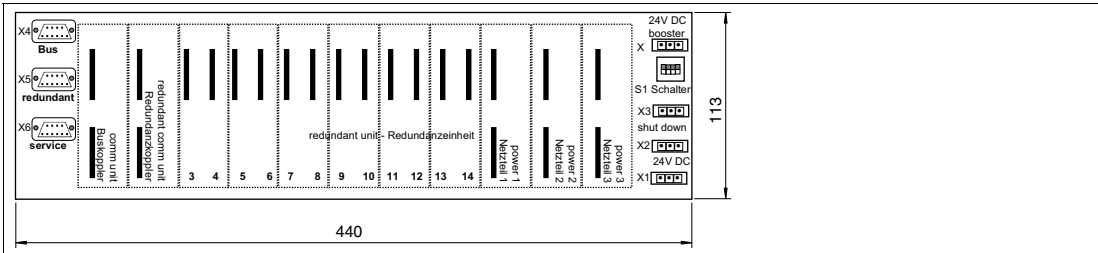

Figure 2.8 Dimensions of the LB9029A



Note

This backplane cannot be extended.

LB9035A

- Base backplane
- Slots for 5 double-width I/O modules

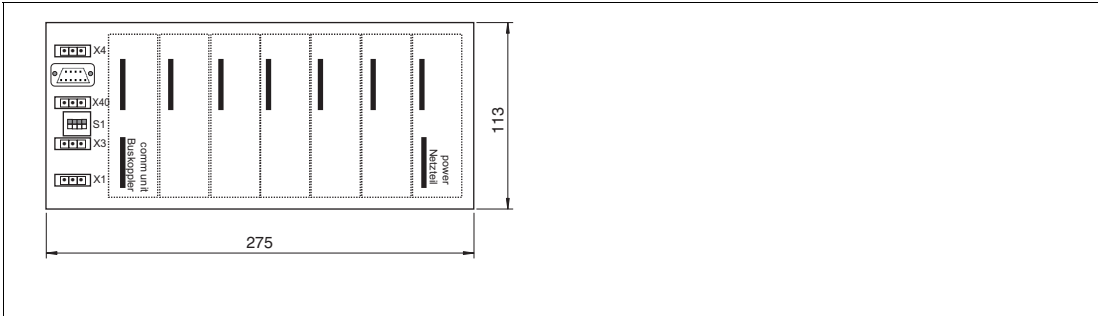

Figure 2.9 Dimensions of the LB9035A



Note

This backplane cannot be extended.

Side view with separation wall

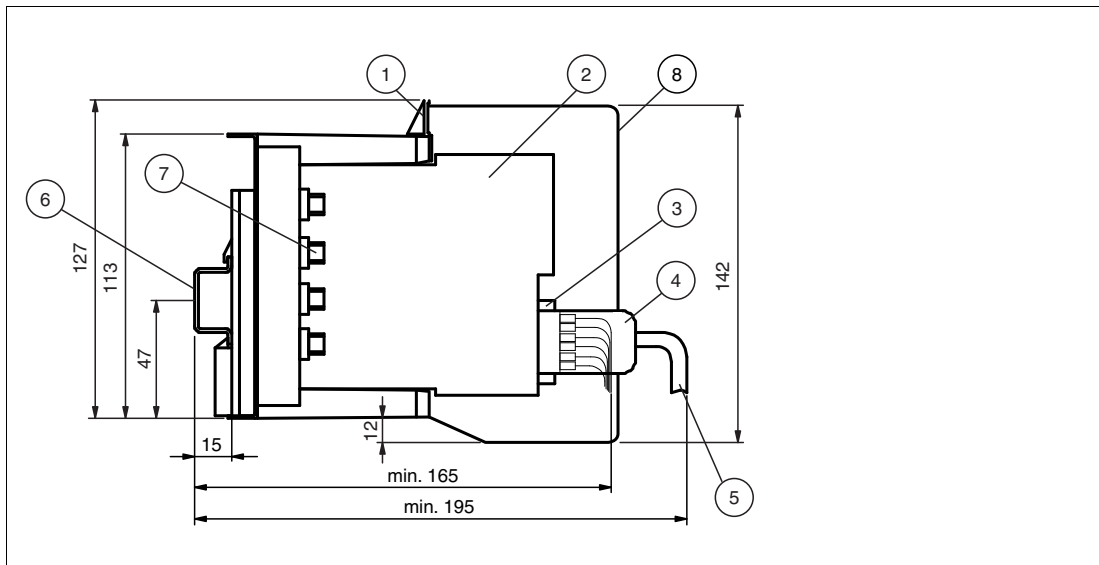

Figure 2.10 Side view of a populated backplane

- 1 Label carrier
- 2 I/O module
- 3 Front connector
- 4 Front connector with protective cover
- 5 Field cable
- 6 NS 35/15 DIN mounting rail
- 7 Fieldbus connection (number of bus connections varies depending on backplane)
- 8 Separation wall LB9182A

2.4.3 Backplane Combinations

Base backplanes can be extended using an extension backplane. The I/O modules on the extension backplane are controlled via the com units on the base backplane. The power supply for the additional I/O modules is provided by additional power supplies on the extension backplane.

The following table describes the base/extension backplane combinations according to the base backplane types. For the exact designations of the possible combinations, see the data sheets of the base backplanes.

Base backplane	Extension backplane
LB9022*	LB9024*
LB9023*	LB9025*
LB9026*	LB9027*
LB9029*	Cannot be extended

Other combinations are not provided.

2.4.4 Backplane and Module Compatibility

In principle, LB backplanes are compatible with all LB modules. Single-width I/O modules occupy one slot, while double-width I/O modules occupy two slots. However, please be aware of the following restrictions.

LB9035A

Only use this backplane with the following I/O modules:

- Digital input: LB1*08*
- Digital output: LB6005*, LB6006*, LB6*08*, LB6*10* ... LB6*15*
- Analog input: LB3*05*, LB5*04*, LB5*05*
- Analog output: LB4*05*

2.4.5 Scope of Delivery

Base backplanes are not delivered with any accessories.

Extension backplanes are delivered with a 1-m-long double-ended cordset (LB9140A). The double-ended cordset establishes the connection to the base backplane.

2.5 I/O Modules, Gateways, Com Units, and Power Supplies

2.5.1 Function

I/O modules are signal conditioning devices. Field signals from a hazardous area are conditioned for controllers or process control systems in a safe area. The slots for the I/O modules on the backplane have equal status, meaning functions can be arranged side by side as required.

Gateways and com units form the interface between the I/O modules and the process control system. A gateway or com unit can control up to 46 I/O modules and transfer their signals across various standard buses. The gateway and the com unit convert the protocol of the bus integrated in the backplane to the communication protocol of the higher-level bus system.

The slots for gateways and com units are mechanically coded on the backplane and marked accordingly. Up to two power supplies provide power to the I/O modules and their gateways and com units on a backplane.



Danger!

Explosion hazard due to excessive power or power dissipation

Excessive consumption of the power supplies can cause the power supplies to overload, which can jeopardize the proper operation of the power supplies from the point of view of explosion protection.

Excessive power dissipation within the surrounding enclosure can cause the maximum permissible surface temperature of the enclosure to be exceeded.

For these two reasons, perform a power consumption and power dissipation calculation for each I/O module and gateway / com unit with respect to your application, as described below. Please also note that a maximum of two power supplies per backplane can be used for power calculation. If a third power supply is installed on the backplane, it serves only as a redundancy feature that can compensate for the failure of another power supply, and does not increase performance. This is also an aspect of explosion protection.

Power consumption of the I/O modules

The power consumption of the I/O modules and gateways / com units can be found in the relevant data sheets. Add these values according to the positioning of the modules on the backplane and compare the total value with the maximum output power of the power supply on the backplane. The power output of the power supply (data sheet specification) must not be exceeded and a maximum of 2 power supplies are permitted for performance analysis.

Some LB611* I/O modules have a booster connection for additional auxiliary energy. For this reason, these modules are only taken into account with a relatively small value when considering the performance of the LB power supplies, which can also be found in the datasheet.

Power dissipation of the I/O modules

The power dissipation of the individual I/O modules, the gateway / com unit, and the power supply can be found in the corresponding datasheets. There is a calculation formula for the power supply.

If a power dissipation value is not specified for an I/O module or gateway / com unit, you can also use the power consumption value. Add these values and compare the total value with the maximum permissible power dissipation of the surrounding enclosure.

If additional loads (no remote I/O) are installed in the cabinet, their power dissipation must also be included in the calculation.

2.5.2 Design and Dimensions

Both single-width and dual-width modules are available. Gateways, com units and power supplies are always dual-width. I/O modules are single-width or dual-width depending on the model.

Both the I/O modules and the gateways, com units and power supplies are equipped with LEDs on the front that display the device status.

The I/O modules have connections on the front to which the relevant field devices are connected.

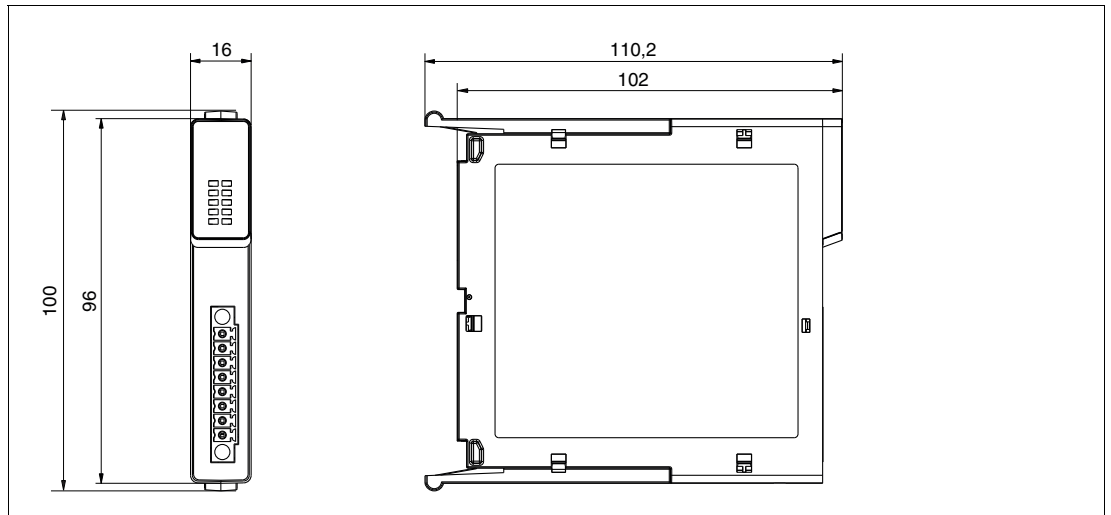

Figure 2.11 Single-width I/O module dimensions

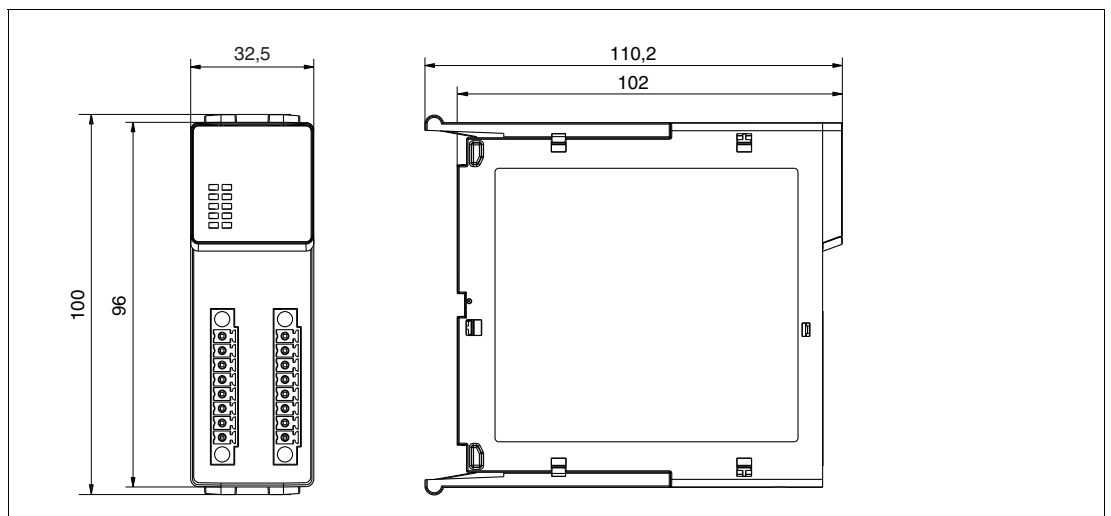

Figure 2.12 Dual-width I/O module dimensions

2.6 Accessories

2.6.1 Bus Connection for RS-485-based Fieldbuses

The following accessories are available for bus connections.

The service bus connection is provided via a 9-pin sub-D connector for all backplanes. The way in which the fieldbus is connected depends on the bus system.

Bus system	Fieldbus connection
PROFIBUS DP/DP-V1	9-pin sub-D connector
MODBUS RTU	
FOUNDATION fieldbus H1	
MODBUS TCP	RJ-45 socket

LB9001A

- Cable inlet at 35
- With connectible terminator
- With connection for a bus monitor or a class 2 master

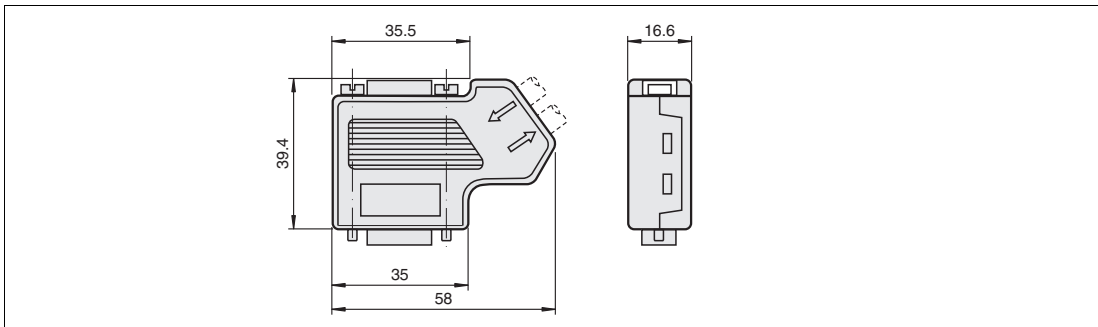

Figure 2.13 Dimensions of the LB9001A

LB9002A

- Axial cable inlet
- With connectible terminator

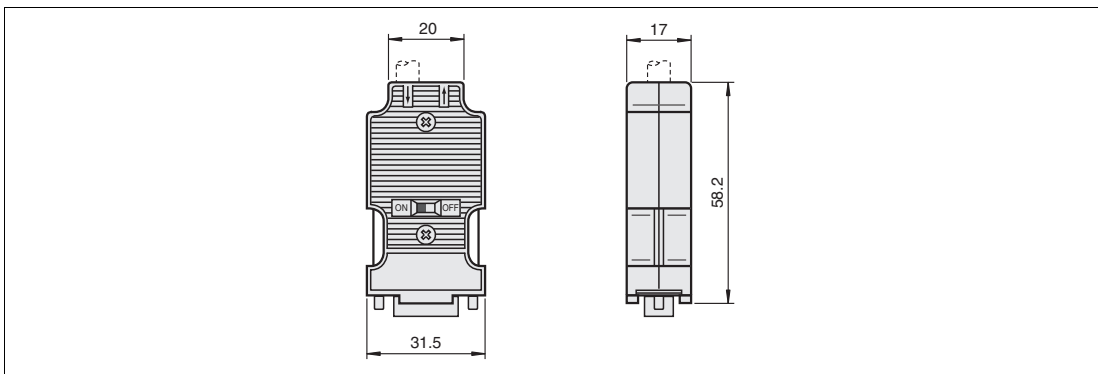

Figure 2.14 Dimensions of the LB9002A

LB9003A

- Cable inlet at 90°
- With connectible terminator
- With connection for a bus monitor or a class 2 master

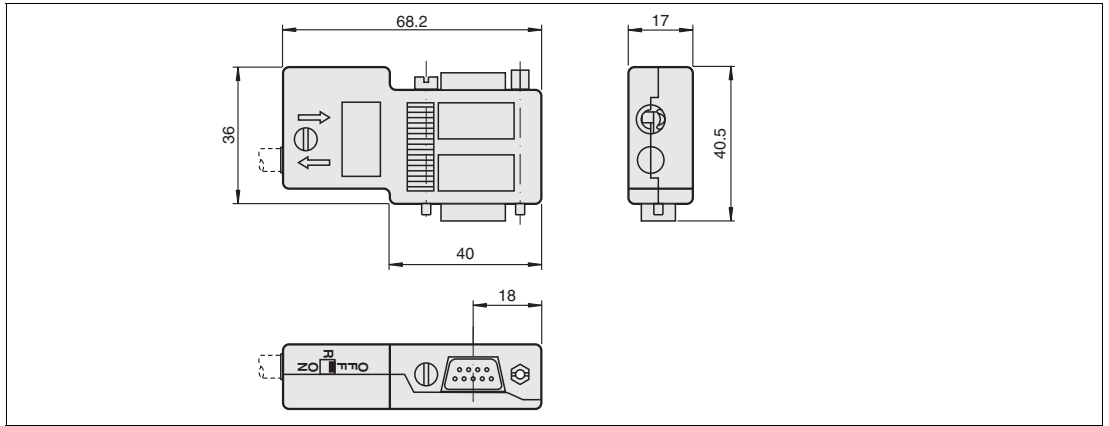

Figure 2.15 Dimensions of the LB9003A

2.6.2 Field Wiring

The following accessories are available for field wiring.

Terminal Blocks

Terminal blocks are wired to the field devices, attached to the front sockets of the I/O modules, and tightened using the side screws. Terminal blocks can come in the form of screw terminals, front screw terminals, or spring terminals. All versions are available in green and blue. Use green terminal blocks for non-intrinsically safe circuits and blue terminal blocks for intrinsically safe circuits.

Because on devices green sockets are used for circuits with the type of protection Ex ic, we recommend to use green plugs with an attached intrinsically safety mark Ex ic.

- **Screw terminals**
 - green: LB9007A, LB9013A, LB9014A
 - blue: LB9107A, LB9113A, LB9124A, LB9125A
- **Front screw terminals**
 - green: LB9017A, LB9018A, LB9019A
 - blue: LB9117A, LB9118A, LB9119A, LB9127A
- **Spring terminals**
 - green: LB9009A, LB9015A, LB9016A
 - blue: LB9107P, LB9115A, LB9116A, LB9126A, LB9130A, LB9131A

Screw Terminals

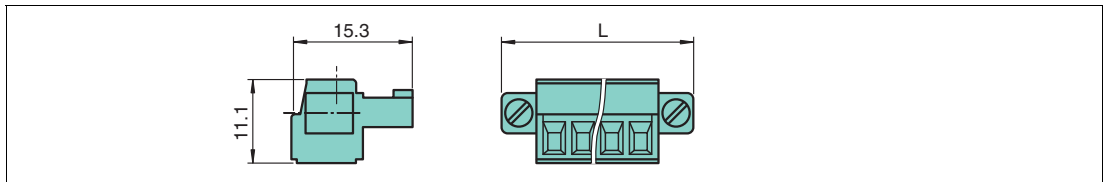

Figure 2.16 Screw terminal dimensions
L = 33.3 mm for 6-pin terminal and 40.9 mm for 8-pin terminal

Front Screw Terminals

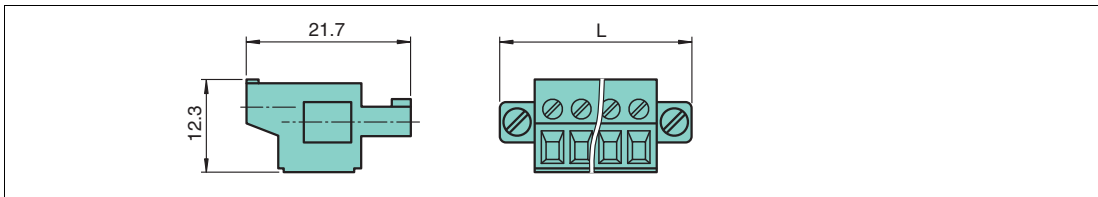

Figure 2.17 Front screw terminal dimensions
 L = 33.3 mm for 6-pin terminal and 40.9 mm for 8-pin terminal

Spring Terminals

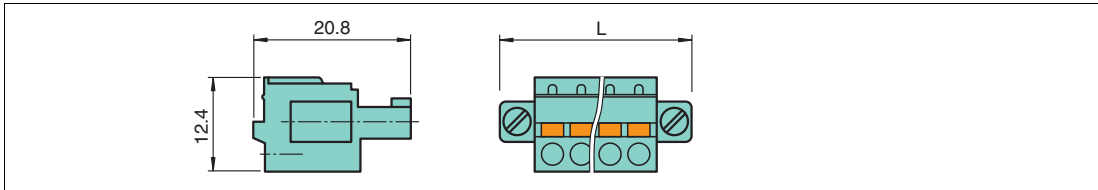

Figure 2.18 Spring terminal dimensions
 L = 33.3 mm for 6-pin terminal and 40.9 mm for 8-pin terminal

Spring Terminals for Single-Width I/O Modules with 2x8 Connections

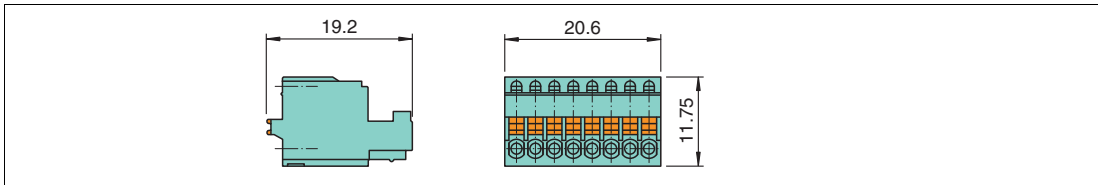

Figure 2.19 Spring terminal dimensions

Protective Covers

Protective covers are used to protect the wiring to the terminal blocks, so that no bare conductive parts are exposed. Protective covers are available in green and blue. Use green protective covers for non-intrinsically safe circuits and blue protective covers for intrinsically safe circuits.

Because on devices green sockets are used for circuits with the type of protection Ex ic, we recommend to use green protective covers with an attached intrinsically safety mark Ex ic.

- **Protective covers**
 - green: LB9008A, LB9010A
 - blue: LB9108A, LB9120A

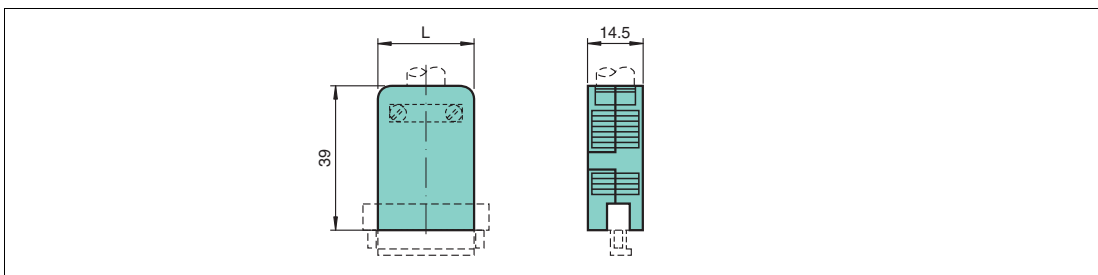

Figure 2.20 Protective cover dimensions
 L = 25.25 mm for protective covers for 6-pin terminals and 32.87 mm for protective covers for 8-pin terminals

Cold Junctions

Cold junctions have a prewired Pt100 thermocouple on plug openings 1 and 2 for numerically correcting the thermoelectric voltage. Cold junctions are available in green and blue. Use green cold junctions for non-intrinsically safe circuits and blue cold junctions for intrinsically safe circuits.

Because on devices green sockets are used for circuits with the type of protection Ex ic, we recommend to use green cold junctions with an attached intrinsically safety mark Ex ic.

- **Cold junctions**
 - blue: LB9112A
- **Cold junctions with a protective cover**
 - green: LB9011A
 - blue: LB9111A

Cold Junction

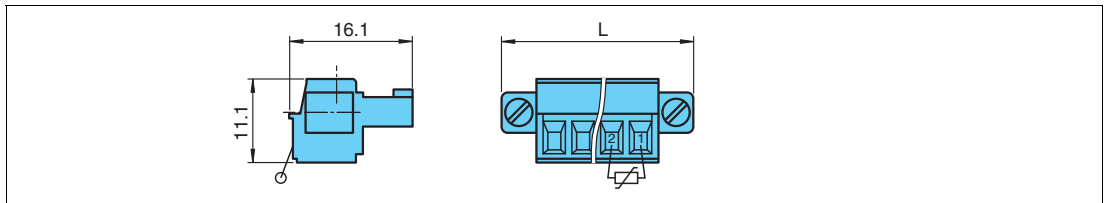

Figure 2.21 Cold junction dimensions
L = 33.3 mm for 6-pin terminal

Cold Junction with a Protective Cover

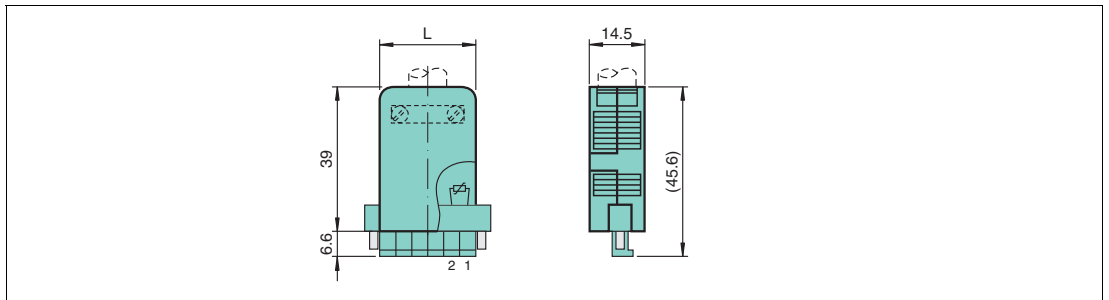

Figure 2.22 Dimensions of a cold junction with a protective cover
L = 33.3 mm for 6-pin terminal

Coding Pins

Coding pins provide a unique assignment between I/O modules and terminal blocks or the associated field devices. To do this, the coding pins are pushed into the grooves provided in the front sockets of the I/O modules. This prevents terminal blocks from being accidentally plugged into another I/O module.

- **Coding pins**
 - KF-CP for LB9007A, LB9009A, LB9013A ... LB9019A, LB9107A, LB9107P, LB9113A, LB9115A ... LB9119A, LB9124A ... LB9127A, LB9130A, LB9131A
 - CP-MC 0.5 (Phoenix Contact order number 1881435) for LB9130A, LB9131A

KF-CP

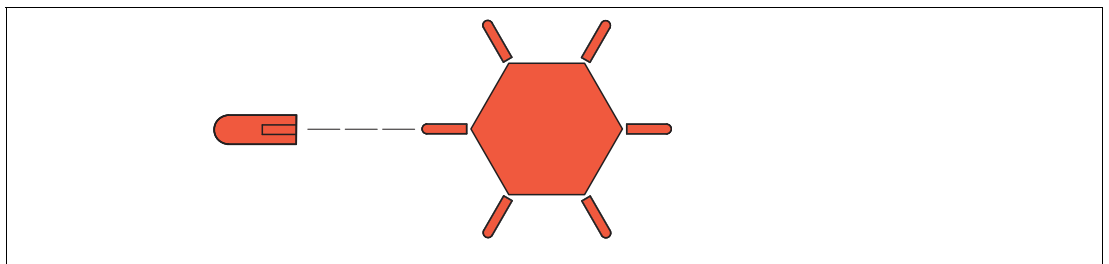

Figure 2.23 KF-CP coding pins

Watchdog Plugs

The watchdog plug is used with digital outputs with a feedback input (LB2101A ... LB2113E). The watchdog plug sends the output signal from the I/O module back to its input channel, making it possible to check the function of the I/O module, as well as the communication between the process control system and the I/O module.

LB9180A

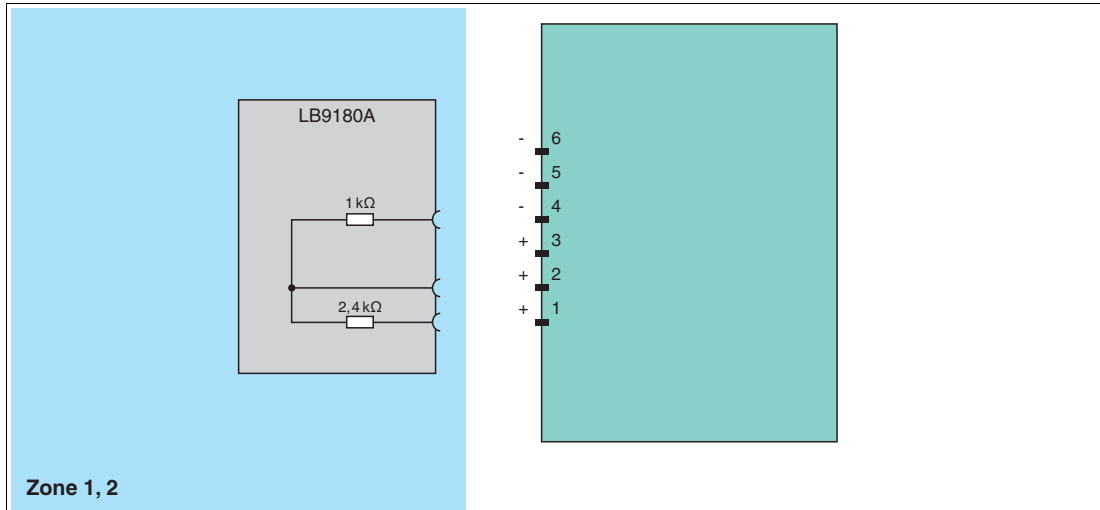

Figure 2.24 Block diagram for the LB9180A

Resistor Network

If binary I/O modules are used, for example, with a mechanical contact, an additional resistor network must be installed to ensure that the line fault detection function can work correctly. Using the additional resistor network, the electronics can distinguish between a closed switch and a short circuit.

F-NR2-Ex1

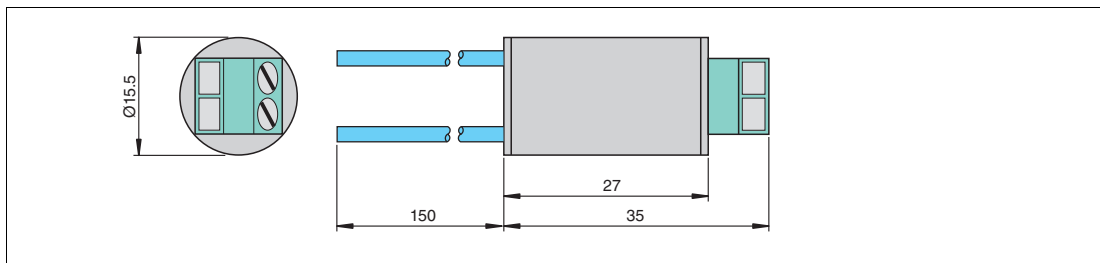

Figure 2.25 Dimensions of the F-NR2-Ex1 resistor network

The resistor network should be installed as close as possible to the sensor to ensure that the line is monitored.

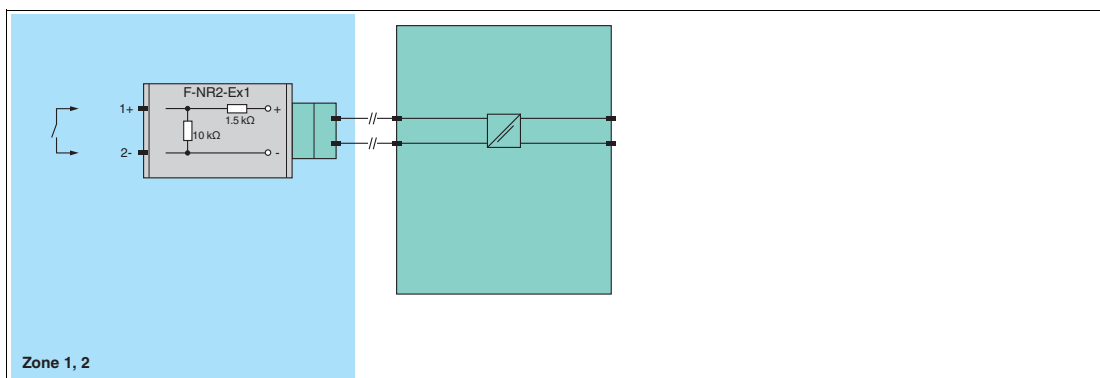

Figure 2.26 Block diagram of the F-NR2-Ex1 resistor network

2024-03

2.6.3 Separation between Intrinsically Safe and Non-Intrinsically Safe I/O Modules

The separation wall is attached to the backplane between I/O modules with intrinsically safe circuits and I/O modules with non-intrinsically safe circuits to ensure a clearance of 50 mm between intrinsically safe circuits and other circuits. The separation wall can be installed on both backplanes with and without a label carrier, see chapter 3.5.

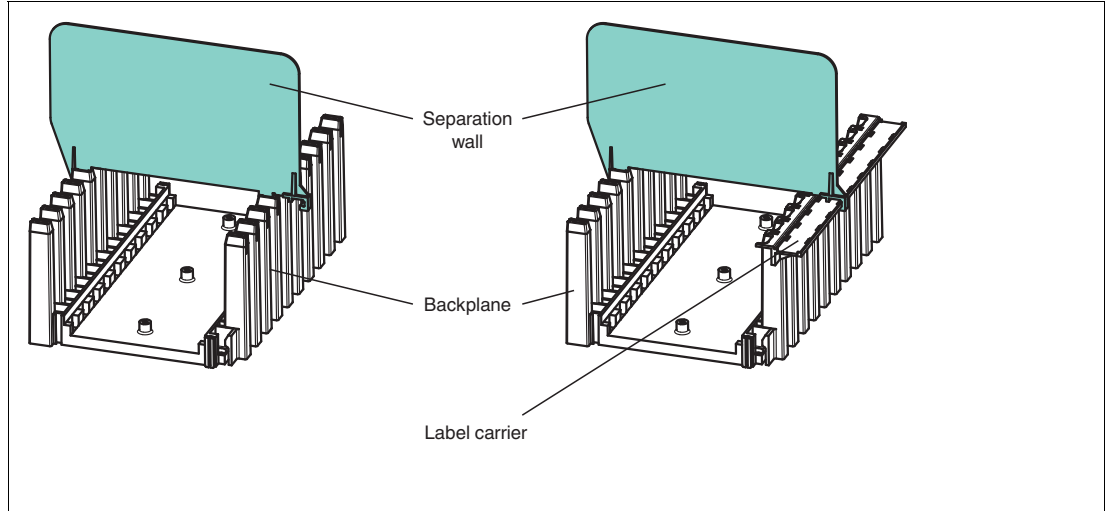

Figure 2.27 Separation wall on the LB9182A

2.6.4 Switch Protection Cover LB9181

The switch protection cover protects the switches, plugs and wiring on the backplane against inadvertent intervention.

The switch protection cover is plugged over the connections on the right side of the backplane and screwed tight using the two screws.

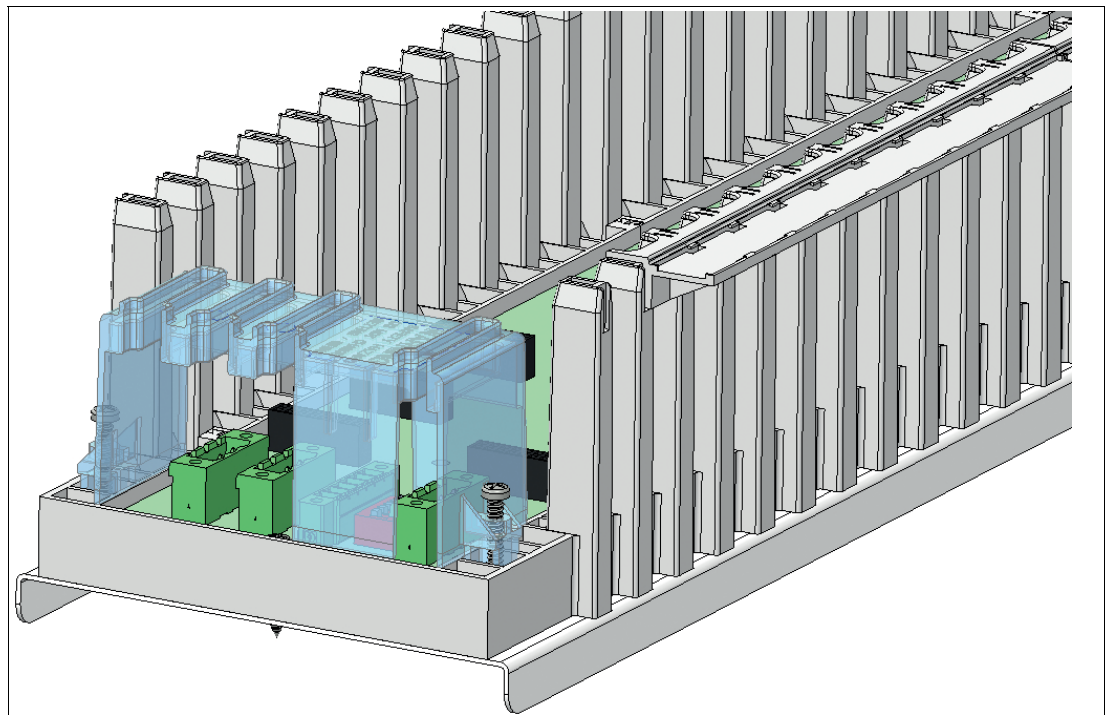

Figure 2.28 Switch protection cover

3 Installation

3.1 Surrounding Enclosure

**Warning!**

Requirements for Equipment Protection Level Gc

The device must be installed and operated only in surrounding enclosures that

- comply with the requirements for surrounding enclosures according to IEC/EN 60079-0,
- are rated with the degree of protection IP54 according to IEC/EN 60529.

**Warning!**

Requirements for Non-Hazardous Areas

The device must be installed and operated only in surrounding enclosures that

- comply with the requirements for surrounding enclosures according to IEC/EN 60079-0,
- are rated with the degree of protection IP54 according to IEC/EN 60529.

Alternatively, it is permitted to install and operate the device in a controlled environment that ensures a pollution degree 2 according to IEC/EN 60664-1.

3.2 Mounting the Backplane

**Mounting the Backplane**

1. Mount the backplane horizontally, if possible, on a NS 35/15 DIN mounting rail.
2. If you install the backplane vertically, arrange the power supplies at the top to achieve a favorable heat distribution. Make sure that the maximum ambient temperature for the components used is not exceeded in this case.

3.3 Connections

At 24 V DC (SELV/PELV) 4 A T fuses are required.

**Warning!**

Danger to life from electric shock.

Absent or insufficient insulation can result in electric shock.

Prevent access to the terminals. Use the switch protection cover as described in the Accessories chapter.

**Caution!**

Property damage due to high voltage

Equipment can be damaged by voltages that are too high, e.g., in temporary faulty operation.

Ensure that the supply voltage of the power supplies used in Zone 2 and safe area does not exceed 32 VDC (SELV/PELV).

3.3.1 Backplanes LB9022* to LB9029* (except LB9022S, LB9024S, LB9022BP22320.1, LB9024BP24300.1)



Danger!

Risk of explosion

Accessories such as plugs and terminators that do not meet the requirements for use in hazardous areas can cause explosive mixtures to ignite.

Only use accessories approved for use in the respective environment.



Danger!

Explosion hazard from live wiring of non-intrinsically safe circuits

If you connect or disconnect energized non-intrinsically safe circuits in a potentially explosive atmosphere, sparks can ignite the surrounding atmosphere.

Only connect or disconnect energized non-intrinsically safe circuits in the absence of a potentially explosive atmosphere.



Danger!

Explosion hazard from sparking when using operating elements

Using operating elements in a potentially explosive atmosphere can cause sparks that can ignite the surrounding atmosphere.

Only use operating elements (e. g., switch, slider, button, etc.) in the absence of a potentially explosive atmosphere.

Backplane Connections on the Left-hand Side (Communication Interface)

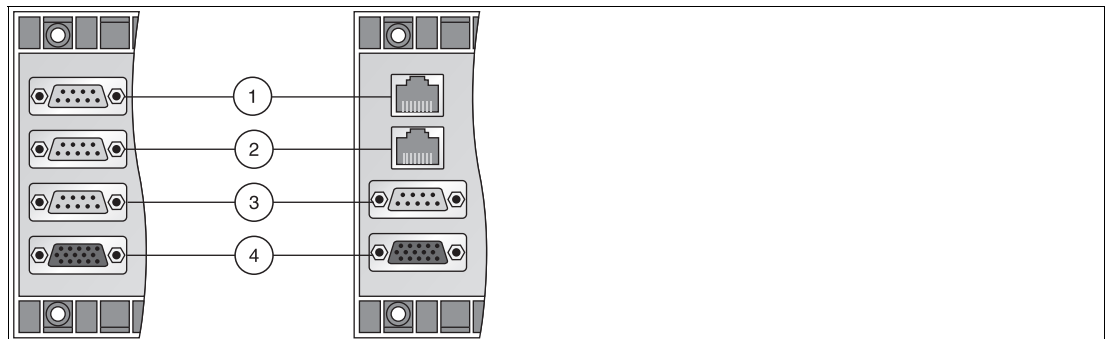

Figure 3.1 Connections on the left-hand side

- 1 **X4:** fieldbus connection
Not present for extension backplanes LB9025A and LB9027A
- 2 **X5:** redundant fieldbus connection
Only present for LB9022E and LB9029A
- 3 **X6:** service bus connection
Not present for extension backplanes LB9025A and LB9027A
- 4 **X7:** extension connection
Not present for backplane LB9029A

Pinning on Sub-D Plugs



Pin 1 -

Pin 2 -

Pin 3 (B) RxD/TxD-P (+) receive/send data P

Pin 4 Optional control signal P

Pin 5 GND reference potential

Pin 6 + 5 V, only at the end of the line

Pin 7 -

Pin 8 (A) RxD/TxD-N (-) receive/send data N

Pin 9 Optional control signal N

When installing, make sure that the transmitting and receiving lines at pin 3 and pin 8 have not been swapped. If the lines have been swapped, the remote I/O station cannot be reached via the fieldbus. If the lines were swapped when looping through, all nodes after this point cannot be reached via the fieldbus.



Activating Bus Termination for RS-485-based Fieldbuses

The fieldbus must have exactly two terminators per segment, one at the start and one at the end. A segment usually starts at the master, while the last remote I/O unit is taken to be the end of the segment.

1. Insert a terminator into the last remote I/O unit of each bus line. We recommend using sub-D plugs with an integrated, connectible terminator. See chapter 2.6.1

Backplane Connections on the Right-hand Side (Supply Circuit and Function Circuit)

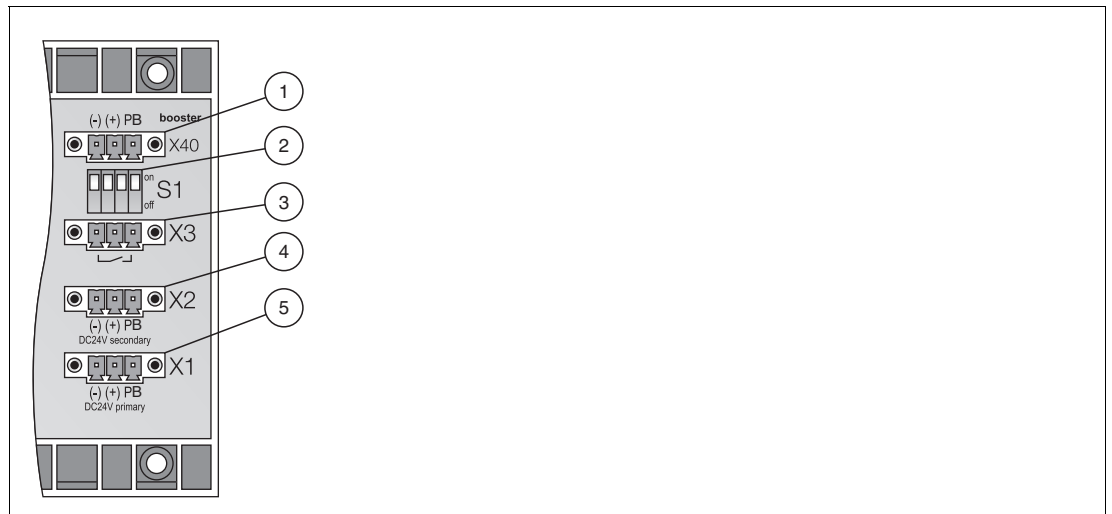

Figure 3.2 Connections on the right-hand side

- 1 **X40:** booster connection
- 2 **S1:** function switch
- 3 **X3:** bus-independent deactivation of the I/O modules
- 4 **X2:** 24 VDC redundant power supply (SELV/PELV)
- 5 **X1:** 24 VDC power supply (SELV/PELV)

X40 Terminal Assignment

Auxiliary energy for 4-channel digital outputs LB6*10* ... LB6*15* can be connected via the booster connection.

- X40.1 = 0 V
- X40.2 = + 24 VDC (SELV/PELV)
- X40.3 = PB (Equipotential bonding)

S1 Switch Positions and X3 Terminal Assignment

The S1 switch and X3 terminal control the bus-independent deactivation of the I/O modules.

The bus-independent deactivation of the I/O modules only works for I/O modules equipped with a shutdown input. I/O modules with and without a shutdown input can be installed on the same backplane; however, only the I/O modules that are equipped with a shutdown input are controlled by the bus-independent deactivation.

If I/O modules equipped with a shutdown input are installed on the backplane, the individual areas can be deactivated using an external switch.



Caution!

Damage to Equipment

Handling the connections improperly can damage the backplane.

- Never supply a control voltage to X3.2
- Only operate multiple adjacent backplanes using a common contact to avoid equalizing currents.

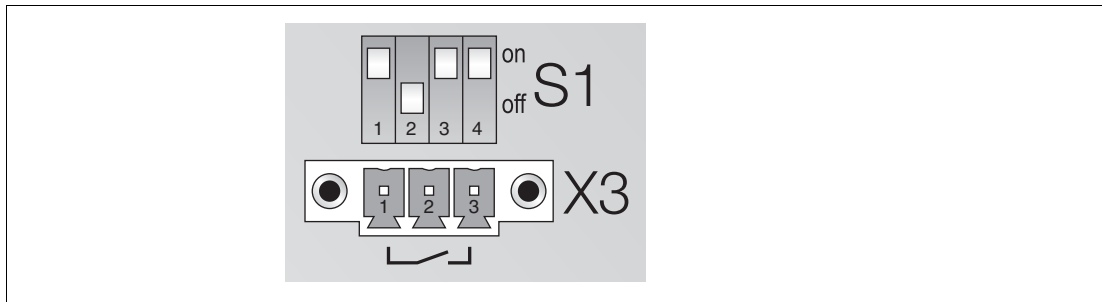

Figure 3.3 X3 terminals and S1 function switches

S1.1	S1.2	S1.3	S1.4	
ON	ON	ON	ON	The shutdown of the I/O modules is deactivated.
ON	OFF	ON	ON	The switch-off of the I/O modules with switch-off input is controlled by the volt-free contact at X3.

- X3.1 = 0 V
Control terminal for all I/O modules with switch-off input.
- X3.1 to X3.3 for external, volt-free contact, galvanic isolated from other contacts and potentials
→ see Figure 3.4 on page 26, position 1.

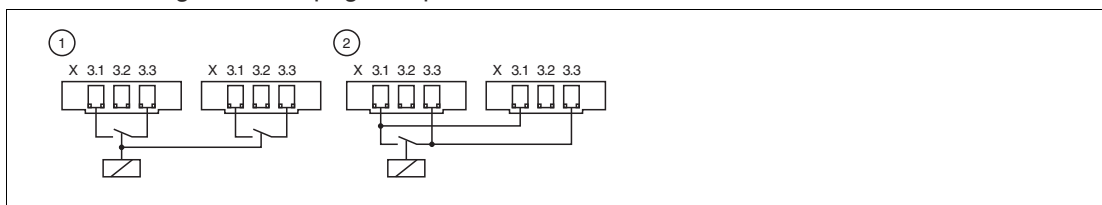

Figure 3.4 Control input X3

- 1 Control for 2 backplanes
- 2 Control for 2 backplanes with common contact
 - Base and expansion backplane can be controlled by either 1 or 2.
 - 2 backplanes with a larger distance can only be controlled by 1.

X2 Terminal Assignment

- X2.1 = 0 V
- X2.2 = + 24 VDC (SELV/PELV)
- X2.3 = PB (Equipotential bonding)

X1 Terminal Assignment

- X1.1 = 0 V
- X1.2 = + 24 VDC (SELV/PELV)
- X1.3 = PB (Equipotential bonding)

3.3.2 Backplanes LB9022S, LB9024S, LB9022BP22320.1, LB9024BP24300.1



Danger!

Risk of explosion

Accessories such as plugs and terminators that do not meet the requirements for use in hazardous areas can cause explosive mixtures to ignite.

Only use accessories approved for use in the respective environment.



Danger!

Explosion hazard from live wiring of circuits

If you connect or disconnect energized circuits in a potentially explosive atmosphere, sparks can ignite the surrounding atmosphere.

Only connect or disconnect energized circuits in the absence of a potentially explosive atmosphere.



Danger!

Explosion hazard from sparking when using operating elements

Using operating elements in a potentially explosive atmosphere can cause sparks that can ignite the surrounding atmosphere.

Only use operating elements (e. g., switch, slider, button, etc.) in the absence of a potentially explosive atmosphere.

Backplane Connections on the Left-hand Side (Communication Interface)

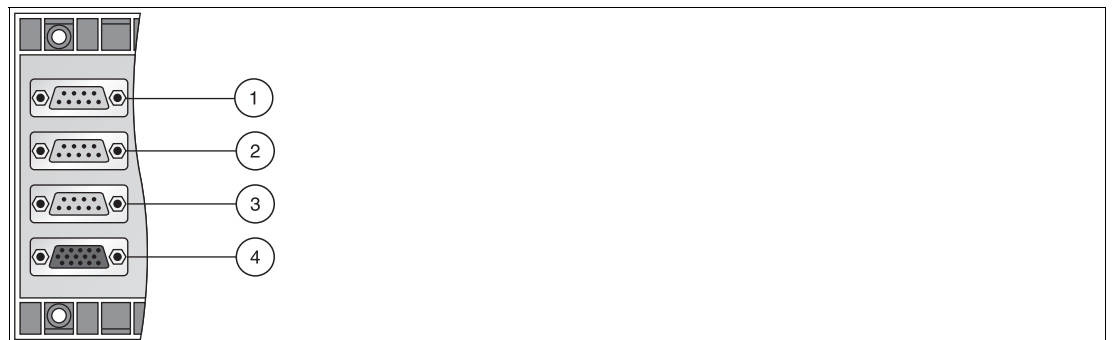
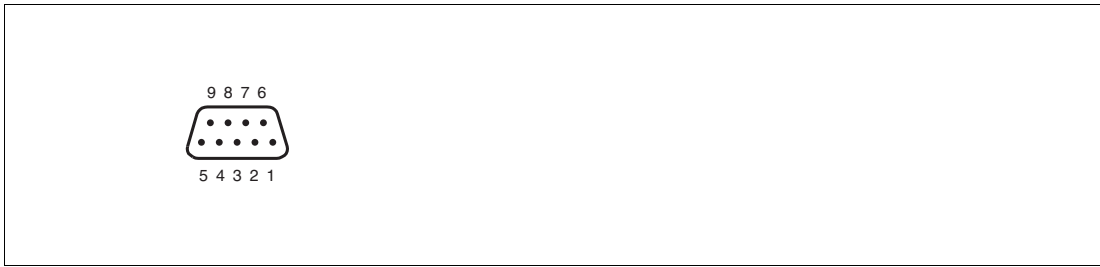

Figure 3.5 Connections on the left-hand side

- 1 **X4:** fieldbus connection
Not present on extension backplane LB9024S
- 2 **X5:** redundant fieldbus connection
Not present on extension backplane LB9024S
- 3 **X6:** service bus connection
Not present on extension backplane LB9024S
- 4 **X7:** extension connection

Pinning on Sub-D Plugs



Pin 1 -

Pin 2 -

Pin 3 (B) RxD/TxD-P (+) receive/send data P

Pin 4 Optional control signal P

Pin 5 GND reference potential

Pin 6 + 5 V, only at the end of the line

Pin 7 -

Pin 8 (A) RxD/TxD-N (-) receive/send data N

Pin 9 Optional control signal N

When installing, make sure that the transmitting and receiving lines at pin 3 and pin 8 have not been swapped. If the lines have been swapped, the remote I/O station cannot be reached via the fieldbus. If the lines were swapped when looping through, all nodes after this point cannot be reached via the fieldbus.



Activating Bus Termination for RS-485-based Fieldbuses

The fieldbus must have exactly two terminators per segment, one at the start and one at the end. A segment usually starts at the master, while the last remote I/O unit is taken to be the end of the segment.

1. Insert a terminator into the last remote I/O unit of each bus line. We recommend using sub-D plugs with an integrated, connectible terminator. See chapter 2.6.1

Backplane Connections on the Right-hand Side (Supply Circuit and Function Circuit)



Figure 3.6 Connections on the right-hand side

- 1 **X40:** booster connection
- 2 **S1:** function switch
- 3 **X3:** bus-independent deactivation of the I/O modules
- 4 **X2:** 24 VDC redundant power supply (SELV/PELV)
- 5 **X1:** 24 VDC power supply (SELV/PELV)

X40 Terminal Assignment

Auxiliary energy for 4-channel digital outputs LB6*10* ... LB6*15* can be connected via the booster connection.

- X40.1 = 0 V
- X40.2 = + 24 VDC (SELV/PELV)
- X40.3 = PB (Equipotential bonding)

S1 Switch Positions and X3 Terminal Assignment

The S1 switch and X3 terminal control the bus-independent deactivation of the I/O modules.

The bus-independent deactivation of the I/O modules only works for I/O modules equipped with a shutdown input. I/O modules with and without a shutdown input can be installed on the same backplane; however, only the I/O modules that are equipped with a shutdown input are controlled by the bus-independent deactivation. The backplanes are divided into five areas. Each area monitors different slots on the backplane.

If I/O modules equipped with a shutdown input are installed on the backplane, the individual areas can be deactivated using an external switch.



Caution!

Damage to Equipment

Handling the connections improperly can damage the backplane.

- Never supply a control voltage to X3.1 ... X3.5. On backplanes LB9022S and LB9024S, bus-independent deactivation of the I/O modules can be controlled by a volt-free contact only.
- Only operate multiple adjacent backplanes using a common contact to avoid equalizing currents.

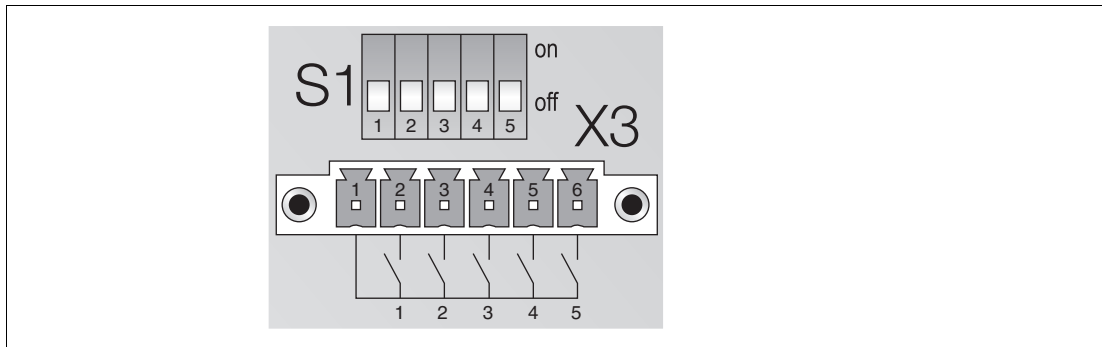

Figure 3.7 Control input X3 and DIP switch S1.1 ... S1.5

Section	1	2	3	4	5
Slots LB9022S	3 ... 5	6 ... 10	11 ... 15	16 ... 20	21 ... 24
Slots LB9024S	25 ... 29	30 ... 34	35 ... 39	40 ... 44	45 ... 48
S1 switch	S1.1	S1.2	S1.3	S1.4	S1.5
X3 switch	X3.2	X3.3	X3.4	X3.5	X3.6

S1.1 ... S1.5	Impact
S1.x = ON	The shutdown of the I/O modules in the corresponding area is deactivated.
S1.x = OFF	The switch-off is controlled in the associated area by the associated X3 contact. If the X3 contact is open (X3.x = OFF), the I/O modules with switch-off input are switched off for the associated range.

X2 Terminal Assignment

- X2.1 = 0 V
- X2.2 = + 24 VDC (SELV/PELV)
- X2.3 = PB (Equipotential bonding)

X1 Terminal Assignment

- X1.1 = 0 V
- X1.2 = + 24 VDC (SELV/PELV)
- X1.3 = PB (Equipotential bonding)

3.3.3 LB9035A



Danger!

Risk of explosion

Accessories such as plugs and terminators that do not meet the requirements for use in hazardous areas can cause explosive mixtures to ignite.

Only use accessories approved for use in the respective environment.



Danger!

Explosion hazard from live wiring of circuits

If you connect or disconnect energized circuits in a potentially explosive atmosphere, sparks can ignite the surrounding atmosphere.

Only connect or disconnect energized circuits in the absence of a potentially explosive atmosphere.



Danger!

Explosion hazard from sparking when using operating elements

Using operating elements in a potentially explosive atmosphere can cause sparks that can ignite the surrounding atmosphere.

Only use operating elements (e. g., switch, slider, button, etc.) in the absence of a potentially explosive atmosphere.



Figure 3.8 Connections

- 1 X4: fieldbus connection
- 2 X6: service bus connection
- 3 X40: booster connection
- 4 S1: function switch
- 5 X3: bus-independent deactivation of the I/O modules
- 6 X1: 24 VDC power supply (SELV/PELV)

X4 Terminal Assignment

- X4.1 = - FF H1
- X4.2 = shield
- X4.3 = + FF H1

The grounding of the shield depends on the position of switch S1.

S1.3	
ON	The shield is connected directly to PB (Equipotential bonding).
OFF	The shield is connected to PB (Equipotential bonding) via capacitive means.

Pinning on Sub-D Plugs

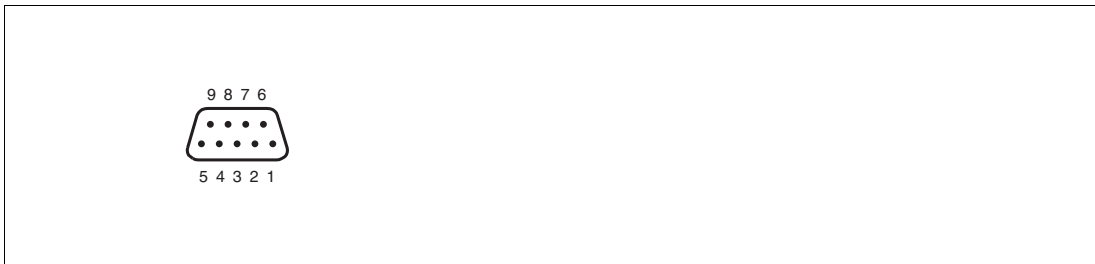

Pin 1 -

Pin 2 -

Pin 3 (B) RxD/TxD-P (+) receive/send data P

Pin 4 Optional control signal P

Pin 5 GND reference potential

Pin 6 + 5 V, only at the end of the line

Pin 7 -

Pin 8 (A) RxD/TxD-N (-) receive/send data N

Pin 9 Optional control signal N

When installing, make sure that the transmitting and receiving lines at pin 3 and pin 8 have not been swapped. If the lines have been swapped, the remote I/O station cannot be reached via the fieldbus. If the lines were swapped when looping through, all nodes after this point cannot be reached via the fieldbus.

X40 Terminal Assignment

Auxiliary energy for 4-channel digital outputs LB6*10* ... LB6*15* can be connected via the booster connection.

- X40.1 = 0 V
- X40.2 = + 24 VDC (SELV/PELV)
- X40.3 = PB (Equipotential bonding)

S1 Switch Positions and X3 Terminal Assignment

The S1 switch and X3 terminal control the bus-independent deactivation of the I/O modules. The terminator on the X4 fieldbus connection can also be activated and deactivated using the S1 switch.

S1.4	
ON	The terminator on the X4 fieldbus connection is activated.
OFF	The terminator on the X4 fieldbus connection is deactivated.

The bus-independent deactivation of the I/O modules only works for I/O modules equipped with a shutdown input. I/O modules with and without a shutdown input can be installed on the same backplane; however, only the I/O modules that are equipped with a shutdown input are controlled by the bus-independent deactivation.

If I/O modules equipped with a shutdown input are installed on the backplane, these modules can be deactivated, for example, using an external switch.



Caution!

Damage to Equipment

Handling the connections improperly can damage the backplane.

- Never supply a control voltage to X3.2 when the S1 switch is closed (S1.x = ON).
- Only operate multiple adjacent backplanes using a common control voltage or a common contact to avoid equalizing currents.

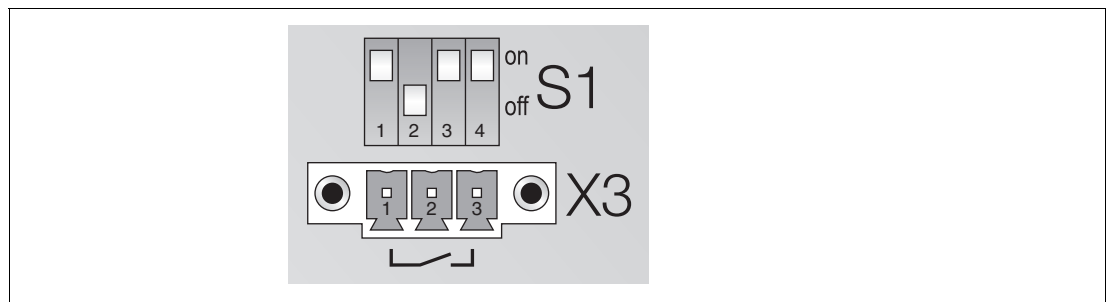

Figure 3.9 X3 terminals and S1 function switches

S1.1	S1.2	
ON	ON	Deactivation of the I/O modules is disabled.
OFF	OFF	Deactivation of the I/O modules equipped with a shutdown input is controlled by a control voltage at X3.
ON	OFF	Deactivation of the I/O modules equipped with a shutdown input is controlled by a voltage-free contact at X3.

- X3.1 = 0 V
- X3.2 = 12 ... 24 V DC galvanically isolated control voltage (SELV/PELV), → see Figure 3.4 on page 26, item 1
Control current = n x voltage / 5,6 kΩ (where n = number of I/O modules equipped with a shutdown input)
- X3.1 to X3.3 for external, volt-free contact, galvanically isolated from other contacts and potentials, → see Figure 3.4 on page 26, item 2. This separation also applies to other contacts from other backplanes, unless this involves interconnecting the base backplane and the extension backplane, → see Figure 3.4 on page 26, item 3. The status information for the external contact can be read, for example, in using the LB1*08* I/O module.

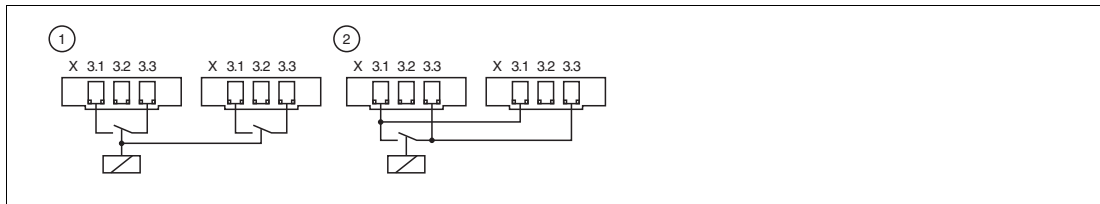

Figure 3.10 Control input X3

- 1 Control for 2 backplanes
- 2 Control for 2 backplanes with common contact
 - Base and expansion backplane can be controlled by either 1 or 2.
 - 2 backplanes with a larger distance can only be controlled by 1.

X1 Terminal Assignment

- X1.1 = 0 V
- X1.2 = + 24 VDC (SELV/PELV)
- X1.3 = PB (Equipotential bonding)

3.4 Inserting and Removing Modules

Fixed slots are reserved on the backplane for gateways, com units and power supplies. Gateways resp. com units are equipped with mechanical coding pins on the underside of the enclosure to prevent these modules from being accidentally plugged into the slot of an I/O module.

Slots for I/O modules have equal status, meaning functions can be arranged side by side as required. I/O modules with intrinsically safe circuits and I/O modules with non-intrinsically safe circuits can also be arranged side by side. Please note that a clearance of 50 mm must always be maintained between intrinsically safe and non-intrinsically safe circuits. To ensure this clearance is maintained, fit a separation wall between modules with intrinsically safe circuits and modules with non-intrinsically safe circuits.

Unused slots can be left empty or covered using place-holder modules LB9099 and LB9199A.



Note

Only remove I/O modules, gateways, com units and power supplies, in the proven absence of a potentially explosive atmosphere.



Installing I/O Modules

1. Push the I/O module into a vacant slot on the backplane.
2. Separate I/O modules with intrinsically safe circuits and I/O modules with non-intrinsically safe circuits using a separation wall. See chapter 3.5
3. Make a note of the types of module used or other identification codes, if any, on the label carrier above the I/O modules.



Removing I/O Modules

1. Remove the modules by positioning your thumb and index finger on the top and bottom of the module and pulling.

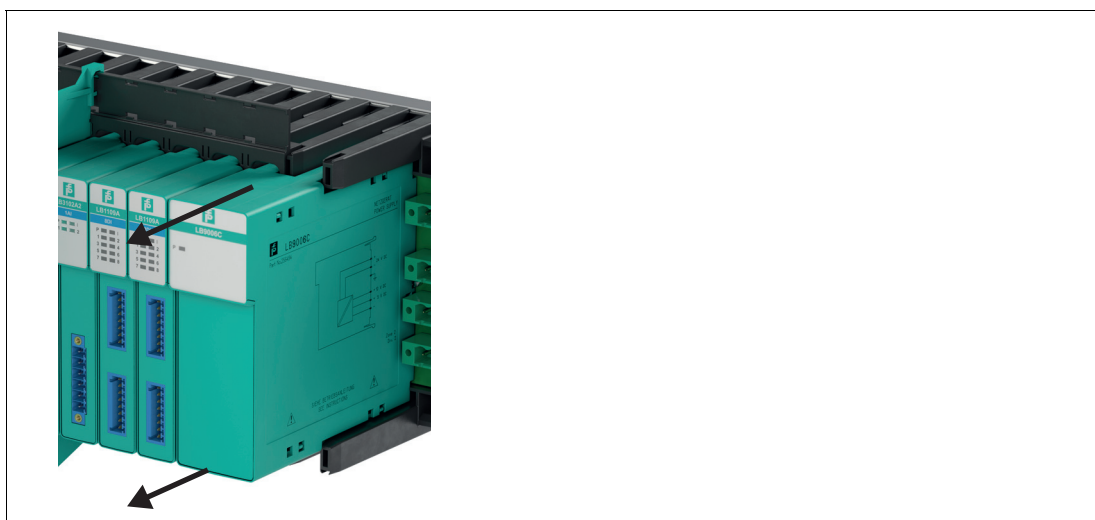

Figure 3.11 Removing modules

2. If necessary, adjust the information on the label carrier above the I/O modules.

3.5 Installing the Separation Wall

The separation wall is attached to the backplane between I/O modules with intrinsically safe circuits and I/O modules with non-intrinsically safe circuits to ensure a clearance of 50 mm between intrinsically safe circuits and other circuits.



Mounting on a Backplane without a Label Carrier

1. Position the pins on the separation wall over the plastic holders on the backplane.

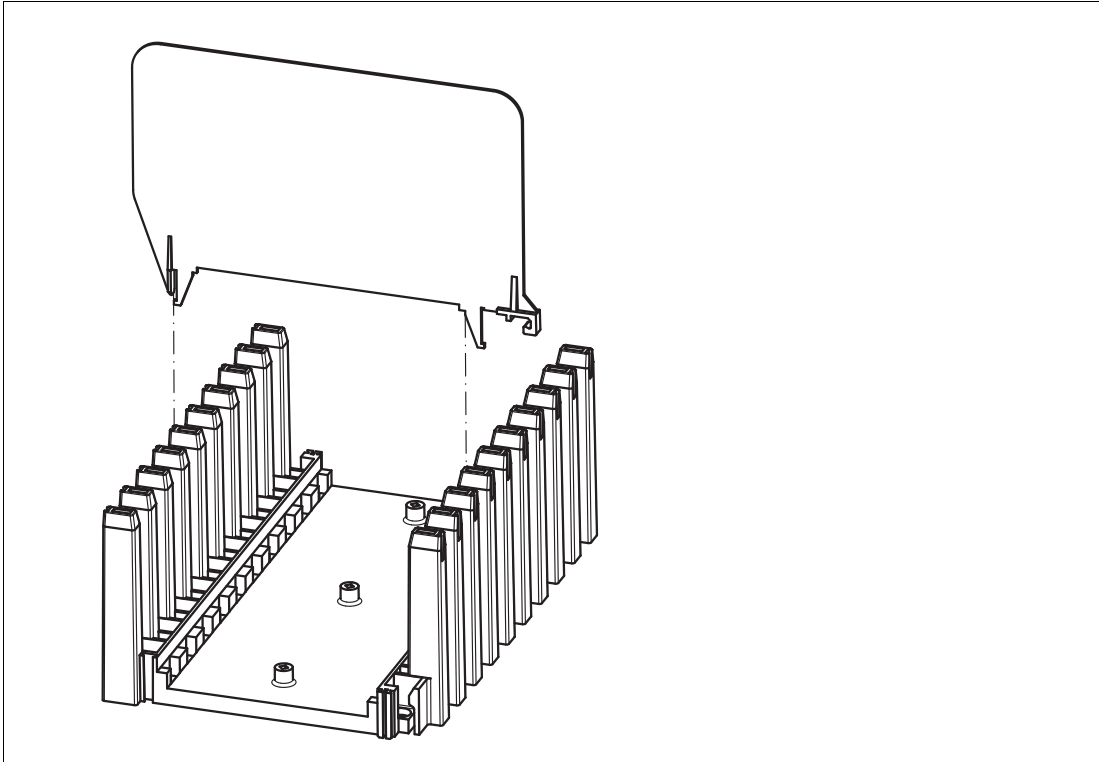

2. Insert the pins on the separation wall into the plastic holders on the backplane, ensuring the pins snap into place.

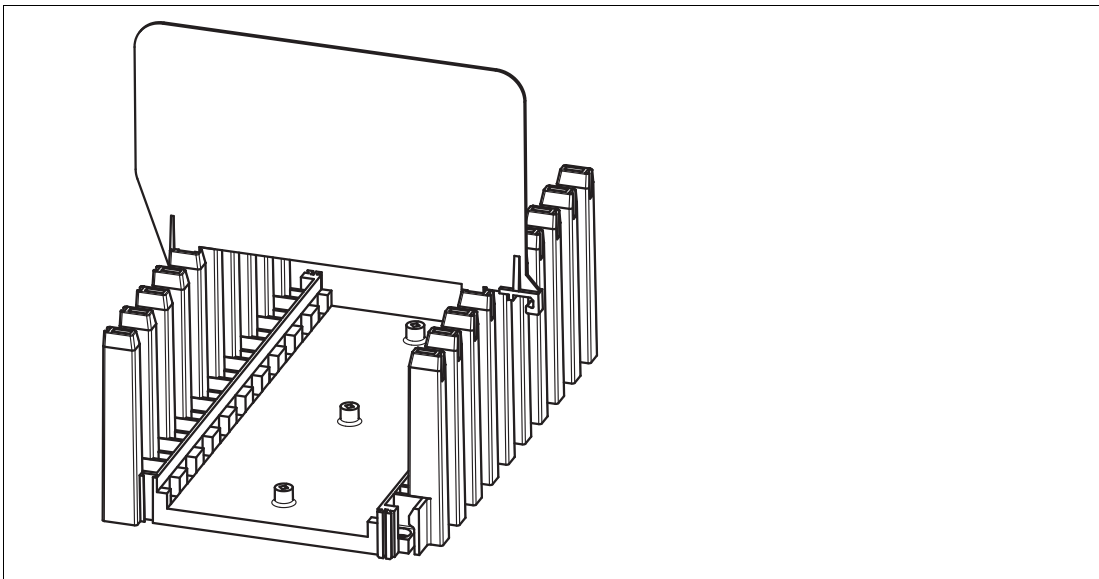

2024-03



Mounting on a Backplane with a Label Carrier

1. Cut off the pin that is located near the catch on the separation wall.

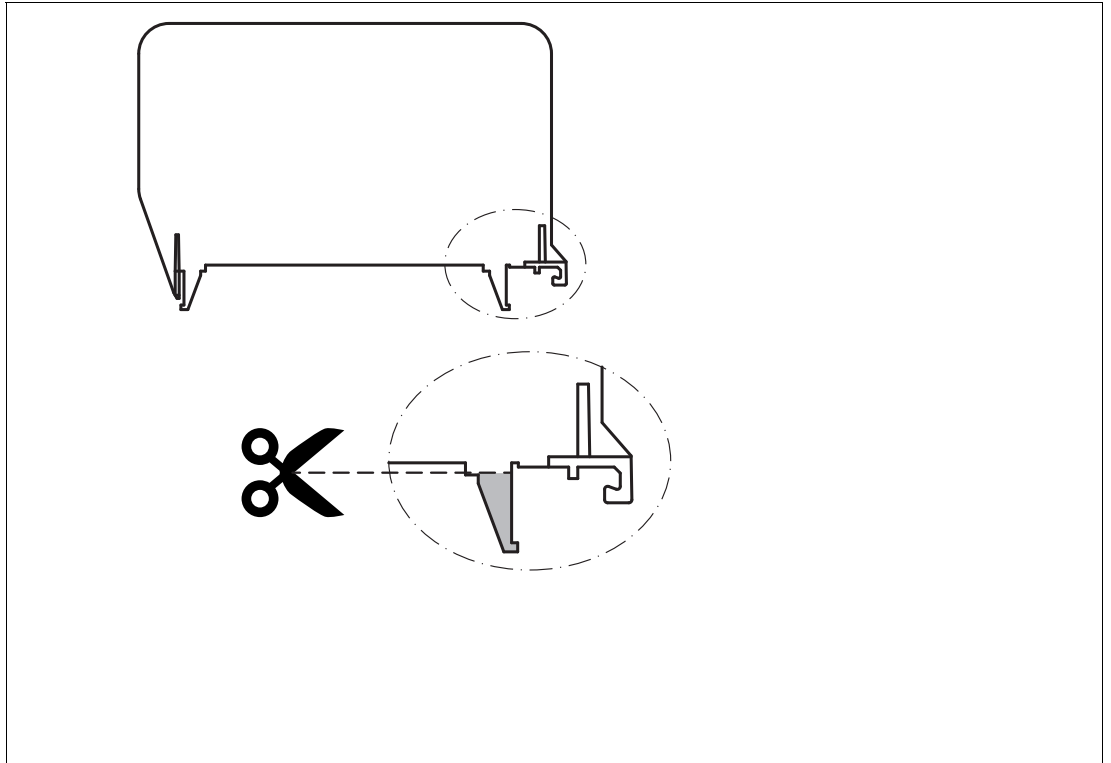

2. Hook the catch into the label carrier.

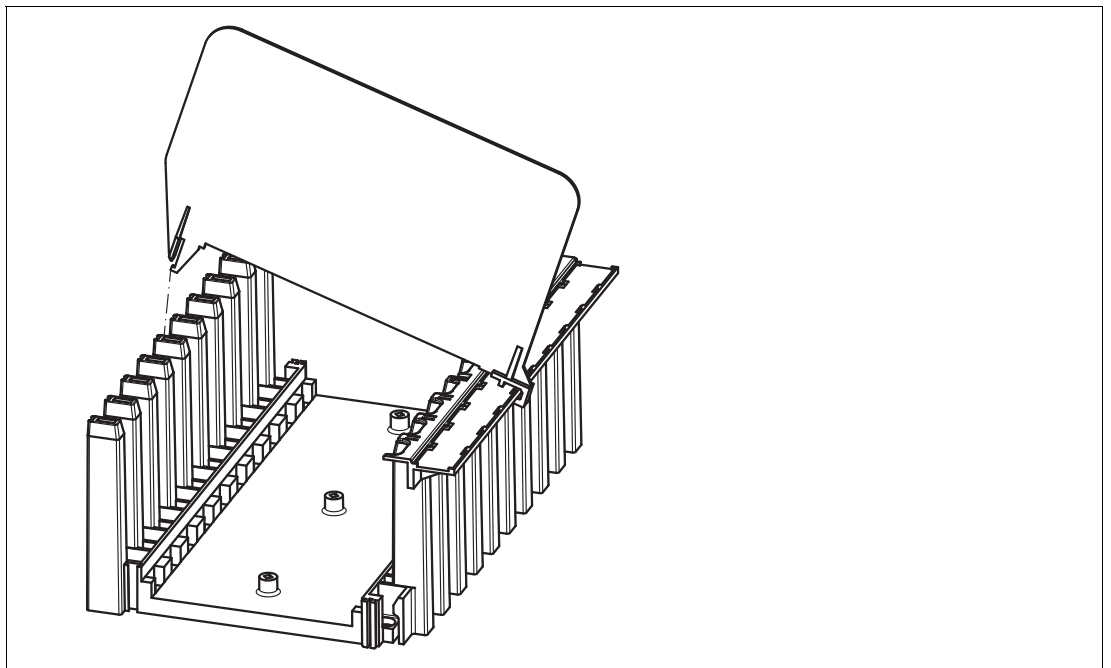

3. Insert the pin on the separation wall into the plastic holders on the backplane, ensuring the pin snaps into place.

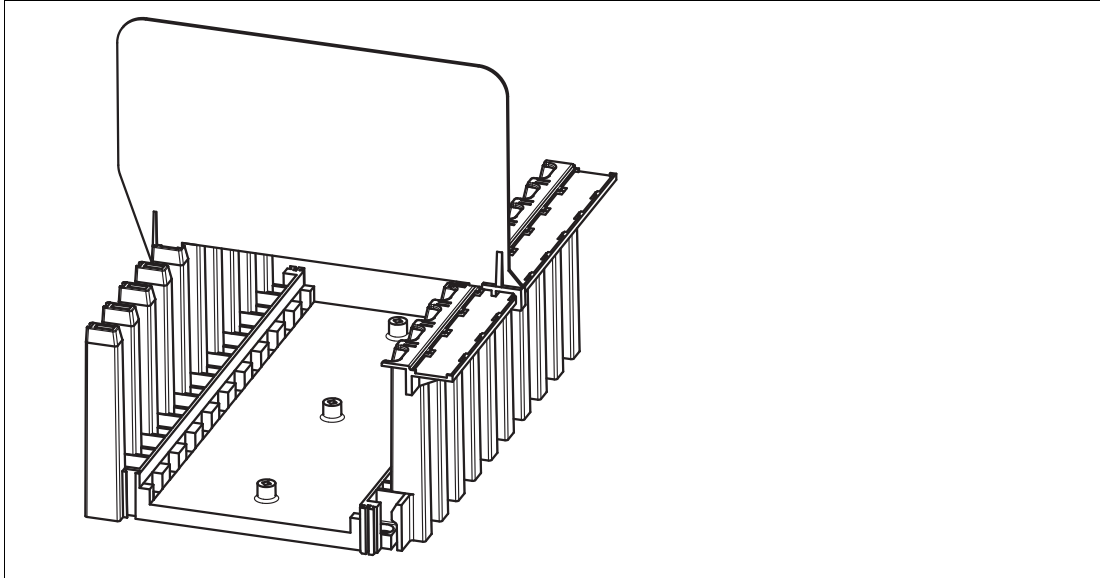

3.6 Field Wiring



Danger!

Risk of explosion

Measuring instruments that do not meet the requirements for use in hazardous areas can cause explosive mixtures to ignite.

Only use accessories and devices that are approved for use in the respective environment.



Danger!

Explosion hazard from loss of intrinsic safety

Circuits with the Ex i type of protection that have been operated with non-intrinsically safe circuits must no longer be used as circuits with Ex i type of protection.

Use only Ex i-certified measuring instruments in conjunction with Ex i-certified I/O modules.

Field connections can be made to the I/O modules using screw terminals, front screw terminals, or spring terminals. Use the terminal blocks from the range of accessories. See chapter 2.6.2

Front screw terminals or spring terminals are ideal for performing extensions at a later point or for changing individual field connections, as the plug can remain in the front socket of the I/O module during wiring. These terminals offer a test plug socket for measuring individual current circuits.

The following connection data applies in conjunction with the terminal blocks listed here: LB9007A, LB9009A, LB9013A ... LB9019A, LB9107A, LB9107P, LB9113A, LB9115A ... LB9119A, LB9124A ... LB9127A, LB9130A, LB9131A.

Connection data for front screw terminals, screw terminals, and spring terminals	
Rigid conductor cross-section	0.14 mm ² ... 1.5 mm ²
Flexible conductor cross-section	0.14 mm ² ... 1.5 mm ²
Flexible conductor cross-section with wire end ferrule with no plastic sleeve	0.25 mm ² ... 1.5 mm ²
Flexible conductor cross-section with wire end ferrule with plastic sleeve	0.25 mm ² ... 0.5 mm ²

The following connection data applies in conjunction with terminal blocks LB9130A and LB9131A.

Connection data for spring terminals for single-width I/O modules with 2x8 connections	
Rigid conductor cross-section	0.14 mm ² ... 0.5 mm ²
Flexible conductor cross-section	0.14 mm ² ... 0.5 mm ²
Flexible conductor cross-section with wire end ferrule with no plastic sleeve	0.25 mm ² ... 0.5 mm ²
Flexible conductor cross-section with wire end ferrule with plastic sleeve	0.25 mm ² ... 0.5 mm ²



Installing Field Wiring



Danger!

Risk of Explosion

Front connections that are improperly wired can result in dangerous mistakes being made and cause potentially explosive mixtures to ignite.

1. The I/O modules are wired differently depending on the model and function. Wire the terminal blocks to the field devices in accordance with the information in the data sheets for the I/O modules used.
2. Pay attention to the conductor cross sections. We recommend that you do not exceed a conductor cross section of 0.75 mm².
3. Make sure that conductors are insulated all the way up to the terminal.
4. If you use stranded conductors, make sure that these are equipped with wire end ferrules. We recommend using wire end ferrules approved according to DIN 46228-4.
5. Use green terminal blocks/protective covers for non-intrinsically safe circuits and blue terminal blocks/protective covers for intrinsically safe circuits.



Tip

Because on devices green sockets are used for circuits with the type of protection Ex ic, we recommend to use green terminal blocks/protective covers with an attached intrinsically safety mark Ex ic.

6. Maintain a minimum clearance of 50 mm between the intrinsically safe and non-intrinsically safe circuits.
7. When modules with intrinsically safe circuit and non-intrinsically safe circuits are directly adjacent, a separation wall must be used. This also applies to cases of an empty slot in between. Insert a separation wall (see chapter 3.5).
8. Plug the terminals into the front sockets of the corresponding I/O modules and tighten the terminals using the side screws, if provided.
9. Fit the cables for intrinsically safe circuits such that they are separate from non-intrinsically safe circuits. Secure all cables using cable ties.
10. Connect unused cables to terminals or ensure that unused cables are fixed securely and insulated.

3.7 Coding

You can code the front sockets of the I/O modules and terminals so that the terminals and the associated field devices can be assigned to exactly one front socket.

Use the KF-CP coding pins for the following terminal blocks: LB9007A, LB9009A, LB9013A ... LB9019A, LB9107A, LB9107P, LB9113A, LB9115A ... LB9119A, LB9124A ... LB9127A, LB9130A, LB9131A. Use the CP-MC 0.5 coding pins (Phoenix Contact order number 1881435) for the LB9130A and LB9131A terminal blocks.



Coding Connections



Caution!

Danger of incorrect connections

If the coding is not unique, terminals can be accidentally swapped.

Establish a unique coding so that every terminal fits exactly one front socket.

1. To code the front socket of an I/O module, insert one or more coding pins into the corresponding grooves on the front socket.
2. In order to code the terminal to match the front socket, cut off the plastic lugs from the terminal from those points where coding pins are located in the front socket.

Note that the coding in example 1 and example 2 is not unique. The terminal from example 1 could be accidentally connected to the front socket in example 2. In contrast, the coding in example 1 and example 3 is unique.

	Example 1	Example 2	Example 3
Terminal			
Front socket			

3.8 Line Fault Detection

Most I/O modules have a line fault detection function that can recognize a lead breakage or a short circuit.

If digital I/O modules are used, for example with a mechanical contact, an additional resistor circuit must be installed to ensure that the line fault detection function can work correctly. Using the additional resistor circuit, the electronics can distinguish between a closed switch and a short circuit. See chapter 2.6.2

- LB1*03*

If you are using rotational direction detection, connect this input to a resistor circuit. The rotational direction input is ignored for devices without rotational direction detection.

- LB1007*, LB1*08*, LB1*09*

24 V and 5 V inputs can only be used when line fault detection is disabled.

- LB2*

The valve control circuit is monitored by a current pulse. This current pulse is brief enough not to operate a connected valve. If the I/O module is being used with indicator lights or sounders, you can switch off the current pulse for each channel. It is not always possible to monitor the valve circuit when booster valves are used because these valves have a storage capacitor that behaves like a short circuit when the valve is switched off.

When booster valves are used, depending on the valve, a 10 k Ω parallel resistor can be connected for line fault detection. If line fault detection is still detected when the valve is off, disable the line fault detection function.

- LB3*, LB4*, LB7*

If the current interface of 4 mA ... 20 mA is used, the saved current and the minimum current of 4 mA will ensure the recognition of a lead breakage or a short circuit without further measures.

For more information, refer to the software manual for the gateway resp. com unit used.

3.9 Cold Junctions in Thermocouples

When measuring thermocouples, a thermoelectric voltage is generated at the material transition between the thermocouple and the copper connection point, which distorts the measurement result. The compensation is done by means of an internal or external cold junction. The temperature at the material transition is determined and the effect of the additional thermoelectric emf in the transmitter is compensated. The external reference junction is located remotely from the transmitter and is connected to the transmitter via copper connecting cables. The temperature of the material transition is either determined with a resistance temperature detector or, in case the external cold junctions were removed, kept at a constant temperature (typically 50 °C, 60 °C) by a thermostat. Both methods can be used with the thermocouple transmitters of the LB system (LB5102* and LB5105*) and can be set accordingly in the configuration tools.

In general, the material transition of an internal cold junction is located in the transmitter or directly at the terminals of the transmitter. The internal reference junction is implemented differently in the transmitters of the LB system. In the LB5102* by a separate plug connector attachment (LB9111A see also accessories) and in the LB5105* directly in the device without further accessories.

Cold junctions are available as accessories. See chapter 2.6.2



Figure 3.12 Cold junction for thermocouple measurements

1. Protective cover
2. Cold junction consisting of a terminal block and a Pt100 thermocouple on terminal openings 1 and 2

The LB9111A connector attachment can also be used as an external cold junction for the LB5102* by using the connected Pt100 to determine the temperature at the material transition. However, the line resistance between transmitter and reference junction falsifies the measurement result due to the transfer in 2-wire technology. Therefore, the line resistance must be specified in the configuration tool for compensation. In the field, it is typically set beforehand to a total value of, e.g., 20 Ohm ... 50 Ohm by connecting a potentiometer in series.

3.10 Line Resistance in Resistance Thermometers

If you operate the LB5*01* and LB5*04* I/O modules in a 2-wire configuration, the line resistance amounts to that of a resistor connected in series to the sensor and affects the measurement result. In order to avoid measurement errors, the line resistance must be measured and compensated for in this configuration. Two options are available here:



Pt100 Short Circuit

1. Short circuit the Pt100 sensor.
2. In the configuration software, set the measuring input of the I/O module to resistance measurement.
For more information, refer to the software manual for the gateway resp. com unit used.
3. Call up the measured value display for the I/O module and make a note of the measured value.
4. In the configuration software, set the measuring input of the I/O module to 2-wire measurement with Pt100 sensor.
5. Enter the measured resistance in the **Line resistance** field. The maximum permissible line resistance is 50 Ω .



Use a Calibrating Resistor

1. Use a calibrating terminal with an integrated calibrating resistor in the sensor supply line.
2. In the configuration software, set the measuring input of the I/O module to 2-wire measurement with Pt100 sensor.
For more information, refer to the software manual for the gateways resp. com unit used.
3. In the configuration software, set the line resistance to 20 Ω .
4. Replace the Pt100 sensor at the measuring point with a 100- Ω measurement resistor.
5. To measure the resistance, call up the measured value display for the corresponding measuring point.
6. Set the displayed value to 0 °C using the calibration potentiometer.
7. Then reconnect the Pt100 sensor.

3.11 Strain Gauge Measurement

I/O modules LB4101* and LB5*02 can be interconnected for strain gauge measurements. Use analog output LB4101* to create a constant current, and the measuring input for temperature input LB5*02* to process the millivolt signal for the resulting bridge voltage.

A constant current of 20 mA is sufficient to power a 350-Ω bridge. A bridge voltage of 7 V is produced. With a bridge sensitivity of 2 mV/V, a voltage of 14 mV results at full load.



Configuring I/O Modules for Strain Gauge Measurement

1. Either set the LB4101* analog output operating mode to **simulation** and select 20 mA as the simulation value, or set a fixed value of 20 mA via the fieldbus.
2. Set the LB5*02* temperature input to a millivolt measurement **mV**.
3. Deactivate the cold junction of temperature input LB5*02* by setting the thermostat temperature for the external cold junction to **0 °C**.

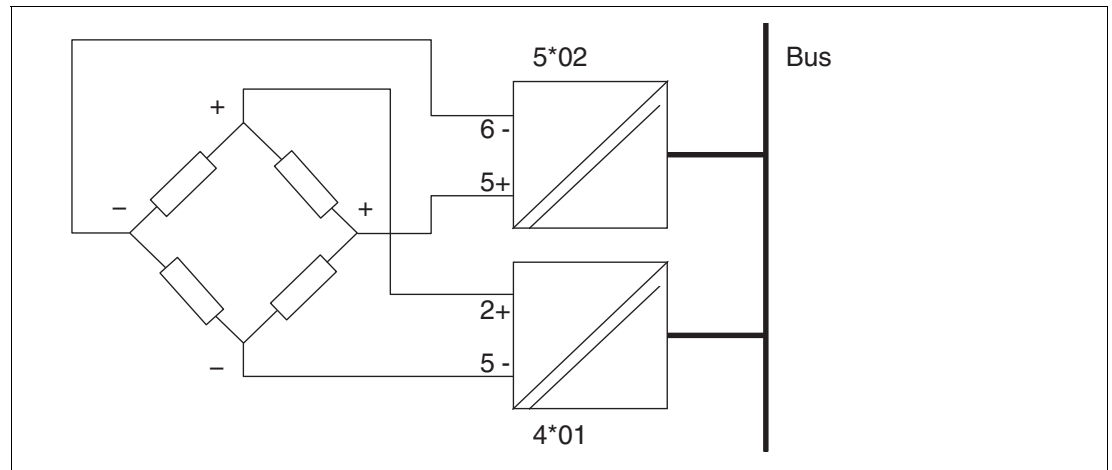

Figure 3.13 Example of a strain gauge bridge

3.12 Status Monitoring of the Output Switch-off

The I/O modules LB1001* and LB1008A enable status monitoring of the output shutdown.



Configuring I/O modules for status monitoring

1. Configure the I/O module as passive voltage input. Deactivate the channel supply. See to the "LB Remote I/O System - Software" manual..



Danger!

Explosion hazard from incorrect connection!

Incorrect installation and configuration of the device may cause sparks and other hazards in potentially explosive atmospheres that could ignite the surrounding atmospheres.

- If you use the I/O module for status monitoring, configure the module as a passive voltage input. Deactivate the channel supply.
- The circuit for the output switch-off is a (non-intrinsically safe) SELV circuit. Disconnect this circuit from other circuits according to explosion protection and electrical safety requirements.
- Keep the isolation distances between the non-intrinsically safe circuit and the intrinsically safe circuits.
- Note that the module loses its suitability for the intrinsic safety type of protection if you connect at least one channel of the module to a non-intrinsically safe circuit.

3.13 Redundancy for PROFIBUS Communication

3.13.1 Basic Principles

Redundancy is used when it is necessary to guarantee operation of a remote I/O station despite one or more components having failed.

To build a redundant system, use backplanes LB9022* and LB9029A and equip these with two com units for com unit redundancy and three power supplies for power supply redundancy. Two power supplies are used to supply the entire backplane. The third power supply is a redundant power supply that can compensate for the failure of another power supply.

It is possible to tell which com unit is active by looking at the operating mode LED. If the operating mode LED is flashing, the com unit is active. If the operating mode LED is not lit, the com unit is passive. For more information about the status LEDs, refer to the data sheet for the relevant com unit in use.

As a general rule, a distinction is made between media redundancy and application redundancy. Com units can be set to media redundancy or application redundancy using the configuration software. For more information, refer to the software manual for the com unit used.

Note

Note that both com units in a redundant system must have the same firmware.



3.13.2 Media Redundancy

As an active switch, a voter converts two redundant PROFIBUS-DP lines into one PROFIBUS-DP line. The voter monitors the activities and the error status of the connected fieldbus lines and decides, depending on the error status, to transmit on one of the two redundant lines. The bus coupler, which then communicates with the master on the basis of this selection, is active and controls the I/O modules on the backplane. The other Bus Coupler is passive, but reads the data traffic on the backplane as well. If the voter now switches to the previously passive Bus Coupler, the latter automatically takes over control of the connected I/O modules on the backplane, and the other Bus Coupler becomes the passive Bus Coupler.

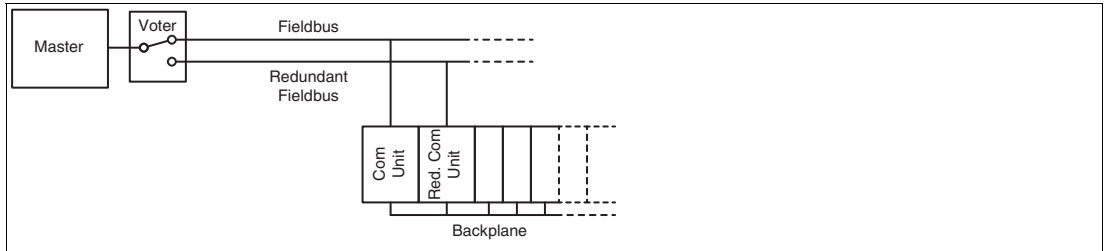

Figure 3.14 Line redundancy

If the master is also redundant, this is known as extended media redundancy.

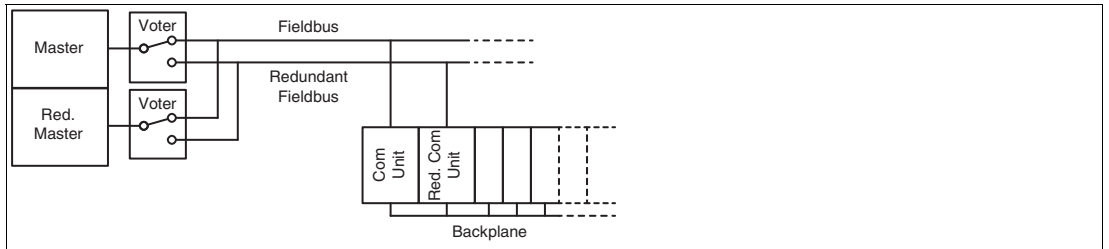

Figure 3.15 Extended media redundancy

3.13.3 Application Redundancy

The application redundancy consists of two complete lines, each containing master, fieldbus and bus coupler. If one fieldbus line or Bus Coupler fails, the master switches over to the redundant fieldbus line. The Bus Coupler, which then communicates with the master on the basis of this selection, is active and controls the I/O modules on the backplane. The other Bus Coupler is passive, but reads the data traffic on the backplane as well. If the master now switches back to the line of the previous passive Bus Coupler, it automatically takes over control of the connected I/O modules on the backplane, and the other Bus Coupler becomes the passive Bus Coupler.

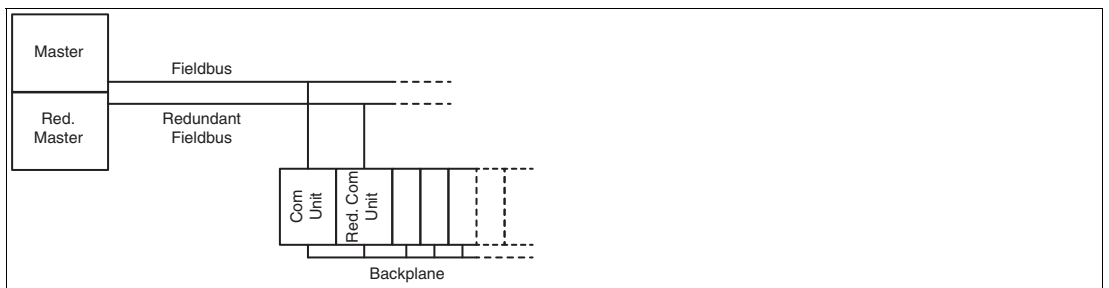

Figure 3.16 Application Redundancy

3.14 Connection of RS-485-based Fieldbuses



Danger!

Risk of explosion

Improperly installed fieldbuses can cause explosive mixtures to ignite.

Observe the wiring specifications set out in IEC/EN 60079-14 for laying lines in a hazardous area.



Danger!

Risk of explosion

Accessories that do not meet the requirements for use in hazardous areas can cause explosive mixtures to ignite.

Only use accessories and devices that are approved for use in the respective environment.

Connection

When possible, use plugs from the range of accessories. See chapter 2.6.1

Cable Lengths

Com units can be configured for various transfer rates. The desired transfer rate and the bus system used dictate the maximum cable length.

For standard applications, the technical data for cable type A in accordance with DIN EN 61158 and DIN EN 61784 applies. The following table relates to standard applications.

Bus system	Transfer rate	Max. cable length
MODBUS	1.2 kbit/s ... 9.6 kbit/s	1200 m
	19.2 kbit/s	1200 m
	38.4 kbit/s	1200 m
	115.2 kbit/s	1000 m
PROFIBUS DP	9.6 kbit/s	1200 m
	19.2 kbit/s	1200 m
	93.75 kbit/s	1200 m
	187.5 kbit/s	1000 m
	500 kbit/s	400 m
	1.5 Mbit/s	200 m
PROFIBUS PA	31.25 kbit/s	1900 m
FOUNDATION fieldbus H1	31.25 kbit/s	1900 m
Service bus	9600 bit/s	1200 m

Repeaters or fiber optic cables such as FOL7250* can be used to extend the cable length.

In accordance with DIN EN 61158 and DIN EN 61784, the following principles apply:

- Linear bus structure without branches, consisting of a cable with terminators
- Length of the spur to the node < 0.3 m
- Total length of all spurs < 6 m
- Data transfer via shielded twisted pair cable
- Terminator resistance 100 Ω ... 130 Ω
- Core cross-section > 0.22 mm², approx. 60 pF/m
- Max. cable length 1200 m, depending on the transfer rate
- Max. 32 active or passive nodes including repeaters
- Max. 3 repeaters between 2 nodes



Example

The following trip values result at rates below 93.75 kBit/s and with the cables connected in series:

- 0 repeaters
 - Max. cable length: 1200 m
 - 1 master + 31 remote I/O stations, each with 48 I/O modules = 1488 I/O modules
- 1 repeater
 - Max. cable length: 2400 m
 - 1 master + 61 remote I/O stations, each with 48 I/O modules = 2928 I/O modules

Terminators

The fieldbus must have exactly two terminators per segment, one at the start and one at the end. A segment usually starts at the master, while the last remote I/O station is taken to be the end of the segment. A segment also ends or begins at a repeater or a fiber optic cable.

A bus with 3 segments, 1 master, a fiber optic cable transfer path, 4 nodes, and 1 repeater has 6 terminators (T).

Master(T) — Node — (T)Fiber optic cable(T) — Node — (T)Repeater(T) — Node — (T)Node

The terminator depends on the line type, as specified in DIN EN 61158 and DIN EN 61784. A distinction is made between:

- R = 220 Ω for line type A (< 12 MBaud)
- R = 150 Ω for line type B (< 0.5 KBaud). Where possible, line type B should no longer be used.
- R = 120 Ω for service bus

Interference

Electromagnetic fields can interfere with the communication path.

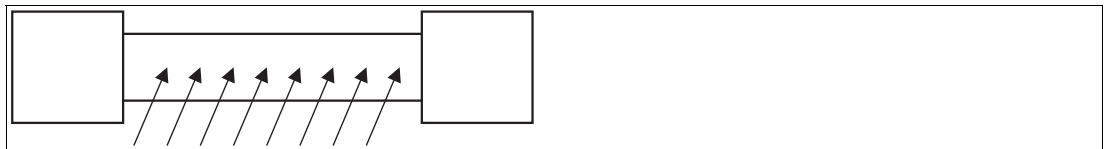

Figure 3.17 Interfering signals caused by induction in parallel conductors

Twisted-pair cables significantly reduce the influence of these interference fields, particularly when compared to cables with parallel strands. The direction of the recorded interference field in a twisted-pair cable reverses over short intervals. This means that the induced interference is practically canceled out, while in parallel strands the interference is active across the entire area.

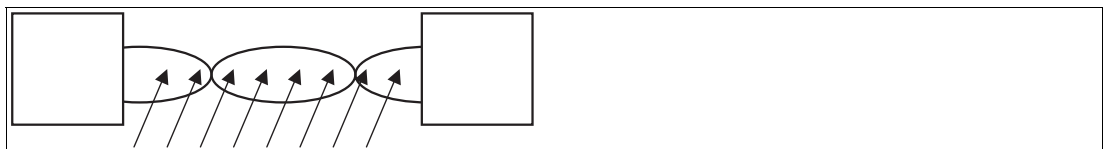

Figure 3.18 Reduced admission of interfering signals in twisted-pair cable

3.14.1 Potential Equalization and Shielding



Note

The following subchapters cannot provide the reader with a complete picture of all requirements in terms of grounding, shielding, and lightning protection. More information on this topic can be found in the technical literature and the applicable standards.

3.14.2 Wiring of the Signal Lines



Danger!

Explosion hazard due to improper installation

Improperly installed wiring can cause explosive mixtures to ignite.

Observe the wiring specifications set out in IEC/EN 60079-14 for laying lines in a hazardous area.

Lay the signal lines such that they are separate from the power cables. Please note that AC voltages and current spikes can induce stray voltages in neighboring lines. Use shielded cables in all cases.

Field wiring (intrinsically safe)

For functional reasons, it may be necessary to connect the cable and line shields to the earth at both ends of the cable. To do this, the system must be designed and maintained in such a way that a high equipotential bonding between the two ends of the circuit, i.e., between the hazardous and the less hazardous area, is ensured.

Under certain conditions, it is even possible to establish the connection to the earth at several intermediate points. The requirements for double-sided or multiple grounding are described in IEC/EN 60079-14, Chapter 16.2.2.3.

Fieldbus Connection

If grounding on both sides of the shield is required for functional reasons, observe the rules of IEC/EN 60079-14, Chapter 6.4.1/9.6.3. If the fieldbus cable is mounted on a grounded metallic cable carrier, a unidirectional grounding can also be sufficient, and is also preferable from the point of view of explosion protection. In addition, observe the rules of IEC/EN 60079-14, Chapter 6.4.1/9.6.3.



Eliminating noise

The following measures can improve power.

1. Fit line filters in power supply lines.
Please make sure that supply cables leading to line filters are laid separately from other cables to ensure that any filtered interference is not picked up again.
2. Fit surge protection filters in signal lines.
3. Change to galvanically isolated circuits.

3.14.3 Shielding and Earthing (Grounding)

For devices in potentially explosive atmospheres, special requirements apply to earthing (grounding), shielding and equipotential bonding, which are described in EN/IEC 60079-14. However national or local regulations may apply in addition to this standard.

To clarify the matter, the two terms protective earthing (grounding) conductor (PE) and equipotential bonding of the hazardous area (PB) need to be distinguished.

Protective earthing (grounding) conductor (PE)

The protective earthing (grounding) conductor provides a protective mechanism against electric shock by diverting electrical currents in the event of a fault, and by triggering an overcurrent protection device or a RCD (residual current device).

However, special regulations for protective earthing (grounding) must be observed in potentially explosive atmospheres. The protective earthing (grounding) is not allowed to be routed via metallic cables that are also used for other functions such as potential equalization in the hazardous location.

Equipotential bonding (PB)

Equipotential bonding is an important part of explosion protection. It ensures that all metallic parts in a hazardous location share the same reference point. In hazardous locations, low-voltage applications shall have an equipotential bonding free of external voltages. Otherwise, sparks or thermal hazards may occur during operation. This can be achieved by separating the equipotential bonding conductor (PB) and the protective earthing (grounding) conductor (PE), as this prevents a possible transfer of dangerous voltages and currents to the equipotential bonding conductor. The equipotential bonding conductor (PB) and the protective earthing (grounding) conductor (PE) must only be connected with each other at a CEP (central earthing (grounding) point). The safety risk in hazardous location is minimized by complying with the installation regulations and using suitable materials and connection methods.

Central earthing (grounding) point (CEP)

A central earthing (grounding) point (CEP) is the gathering point for all protective earthing (grounding) conductors (PE) and equipotential bonding conductors (PB) in the system. It is directly connected to the site earth (ground) electrode in an industrial facility.

The CEP must be rated with a sufficient cross-section in accordance with national or local regulations.



Note

Ensure that no connection between protective earthing (grounding) (PE) and equipotential bonding (PB) is established by other or unintentional means.

1. For example by mounting a device with a metal housing and protective earthing (grounding) (PE) connection in the junction cabinet. Insulated mounting is then required here.
2. Ensure that there is no connection between protective earthing (grounding) (PE) and equipotential bonding (PB) via the shield of the wiring towards the PLC. This is explained below as an example.
3. Note that the PB terminals were historically labeled PE on backplanes delivered in the past. However, they are technically to be handled as PB terminals as defined in this document.

This means a connection between this potential equalization (PB) and a protective earth (grounding) conductor (PE) - as shown in some examples in this document - must also be prevented.

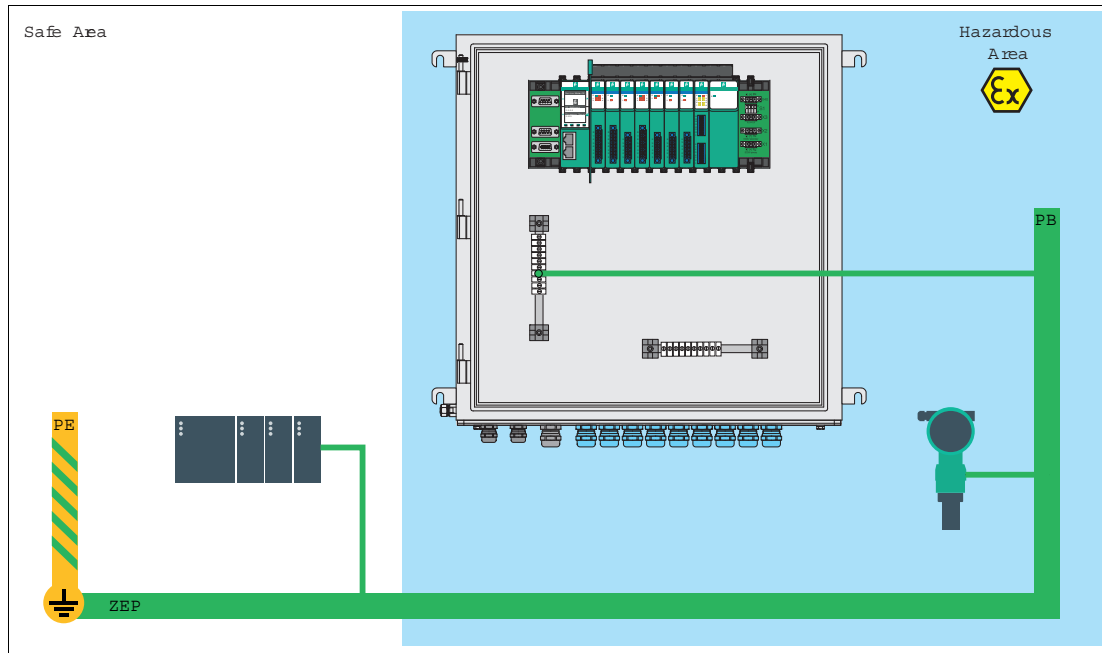

Figure 3.19 Schematic diagram of ZEP, PB, and PE

When using a cable shield, it is generally not permissible to connect the shield directly to protective earthing conductors (PE) in the safe area and directly to equipotential bonding conductors (PB) in the hazardous area simultaneously, due to possible spark generation by high equalization currents.

The connection of the cable shield to protective earthing conductors (PE) in the safe area and to equipotential bonding conductors (PB) in the hazardous area is only permitted if the system is designed and maintained in such a way that a high-quality equipotential bonding between the two areas is ensured. The requirements for grounding the shield on both sides are described in Chapter 16.2.2.3 of the IEC/EN 60079-14 standard. If you want to ground the cable shield on both sides, you must observe the regulations in Chapter 6.4.1/9.6.3 of the IEC/EN 60079-14 standard.

If a system is designed as described above, it is referred to in this document as "high-quality equipotential bonding."

3.14.3.1 Grounding of the Cable Shield with High-Quality Equipotential Bonding Between Safe and Hazardous Areas



Laying the cable shield for serial bus systems

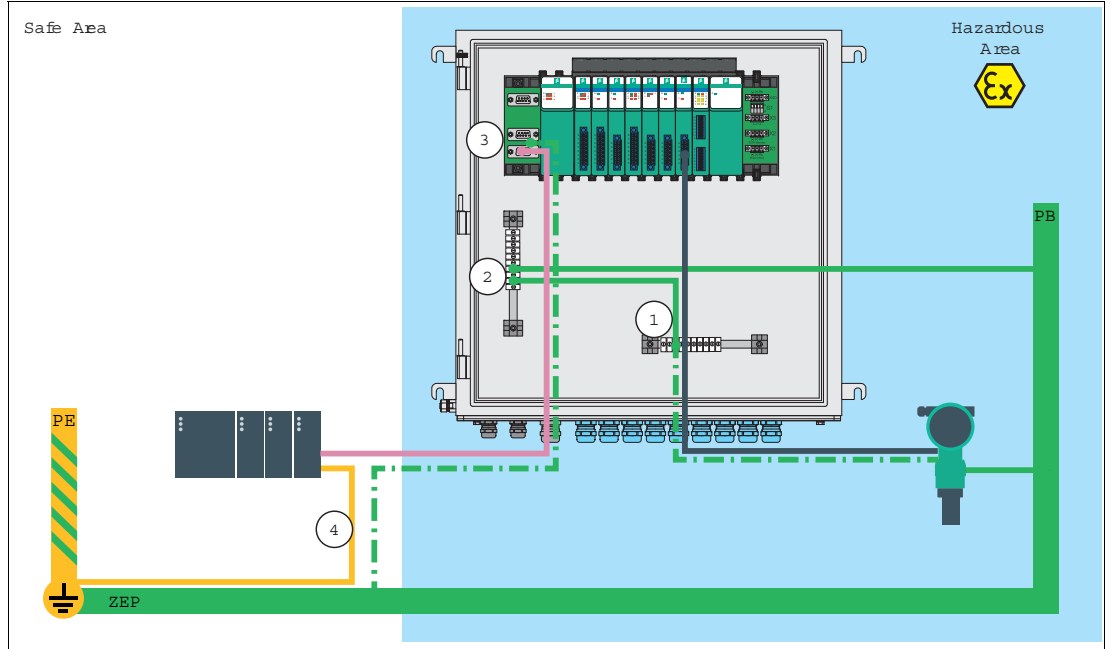

Figure 3.20 Schematic diagram

1. Connect the PB terminals of the backplane to the PB rail (2).



Note

In the case of previously supplied backplanes, the PB terminals are marked with PE, but are technically equivalent and therefore treated as PB terminals in the following.

Alternatively, the connection to the equipotential bonding (PB) can also be made via the DIN mounting rail under the backplane. In this case, however, it must be ensured that the DIN rail is connected to the equipotential bonding (PB) to a sufficient standard.

2. Connect the field signal shield bar (1) to the PB rail (2).
3. Connect the communication cable with the pre-assembled D-Sub connector in the metal housing to the backplane (3).
 - ↳ The conductive connection of the shield to the plug housing establishes a connection to the equipotential bonding (PB) via the D-Sub socket on the backplane.
4. Connect the shield in the non-hazardous area (4) to the standard of equipotential bonding conductor.
5. Disconnect the shield from the protective grounding (PE) in the safe area using suitable terminals or other additional equipment. Make sure that this equipment meets the requirements of the system, including rated voltage, clearance and creepage distances, and high voltage resistance.



Note

Make sure that there is no connection between the protective grounding (PE) and the equipotential bonding (PB) via the PLC.



Laying the cable shield for Ethernet bus systems

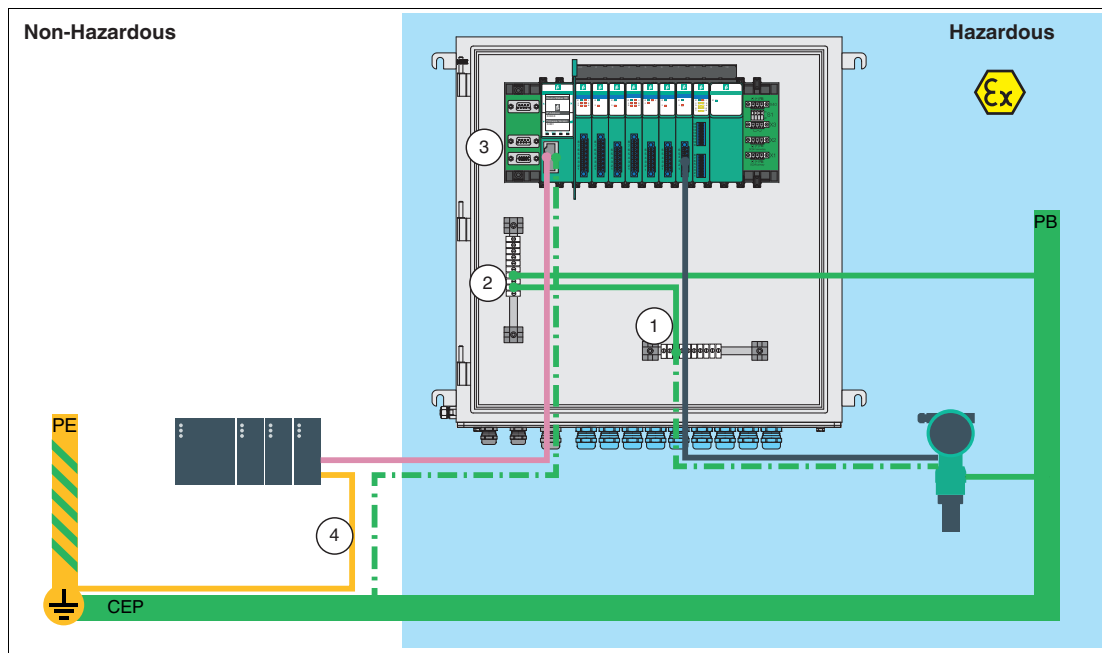

Figure 3.21 Principle representation

1. Connect the PB terminals of the backplane to the PB rail (2).



Note

In the case of previously supplied backplanes, the PB terminals are marked with PE, but are technically equivalent and therefore treated as PB terminals in the following.

Alternatively, the connection to the equipotential bonding (PB) can also be made via the DIN mounting rail under the backplane. In this case, however, it must be ensured that the DIN rail is connected to the equipotential bonding (PB) to a sufficient standard.

2. Connect the field signal shield bar (1) to the PB rail (2).
3. Connect the communication cable to the gateway using the pre-assembled RJ45 plug.
↳ The connection of the shield to the equipotential bonding (PB) of the backplane is made via the RJ45 socket of the gateway.
4. Connect the shield in the non-hazardous area (4) to the standard of equipotential bonding conductor.
5. In the non-hazardous area, disconnect the shield from the protective grounding (PE) using suitable terminals or other additional equipment. Make sure that this equipment meets the requirements of the system, including rated voltage, clearance and creepage distances, and high voltage resistance.



Note

Make sure that there is no connection between the protective grounding (PE) and the equipotential bonding (PB) via the PLC.

3.14.3.2

Single-Sided Grounding of the Fieldbus Shield with Low-Quality Equipotential Bonding Between Safe and Hazardous Areas

If there is **no** high-quality equipotential bonding between safe and hazardous areas in the system, as described in the previous chapter (see chapter 3.14.3.1), at least one single-sided grounding of the fieldbus shield can be implemented to improve electromagnetic compatibility (EMC).

**Laying the cable shield for serial bus systems (single-sided grounding)**

Figure 3.22 Schematic diagram

1. Connect the PB terminals of the backplane to the PB rail (2).

**Note**

In the case of previously supplied backplanes, the PB terminals are marked with PE, but are technically equivalent and therefore treated as PB terminals in the following.

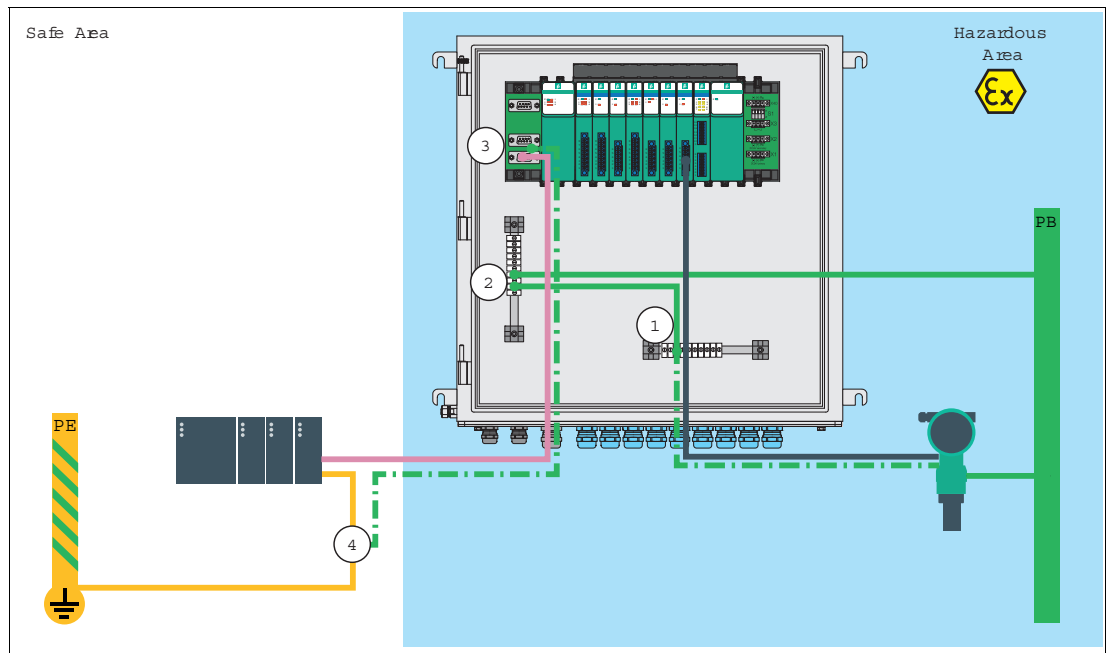
2. Connect the field signal shield bar (1) to the PB rail (2).
3. Connect the communication cable with the pre-assembled D-Sub connector in the metal housing to the backplane (3).
 - ↳ The conductive connection of the shield to the plug housing establishes a connection to the equipotential bonding (PB) via the D-Sub socket on the backplane.
4. In the non-hazardous area (4), disconnect the shield from the protective grounding (PE) using suitable terminals or other additional equipment. Make sure that this equipment meets the requirements of the system, including rated voltage, clearance and creepage distances, and high voltage resistance.

**Note**

Make sure that there is no connection between the protective grounding (PE) and the equipotential bonding (PB) via the PLC.



Laying the cable shield for Ethernet bus systems

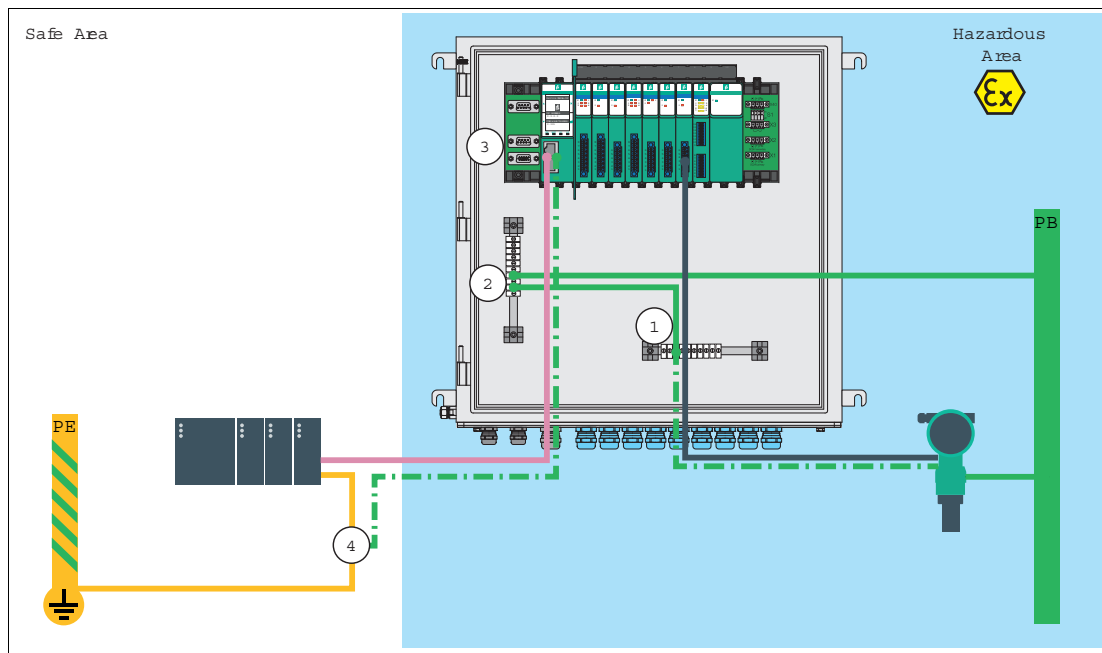

Figure 3.23 Schematic diagram

1. Connect the PB terminals of the backplane to the PB rail (2).



Note

In the case of previously supplied backplanes, the PB terminals are marked with PE, but are technically equivalent and therefore treated as PB terminals in the following.

2. Connect the field signal shield bar (1) to the PB rail (2).
3. Connect the communication cable to the gateway using the pre-assembled RJ45 plug.
↳ The connection of the shield to the equipotential bonding (PB) of the backplane is made via the RJ45 socket of the gateway.
4. In the non-hazardous area (4), disconnect the shield from the protective grounding (PE) using suitable terminals or other additional equipment (e.g., Ethernet network insulator). Make sure that this equipment meets the requirements of the system, including rated voltage, clearance and creepage distances, and high voltage resistance.



Note

Make sure that there is no connection between the protective grounding (PE) and the equipotential bonding (PB) via the PLC.

3.14.3.3

Double-Sided Grounding of the Fieldbus Shield with Low-Quality Equipotential Bonding Between Safe and Hazardous Areas

An alternative option for preventing the direct connection between protective grounding (PE) and equipotential bonding (PB) in accordance with step 4 in Chapter (see chapter 3.14.3.2) is to use a capacitive coupling of the shield with protective earthing (PE) in the non-hazardous area. This can be achieved by using a Y2 capacitor as additional equipment.

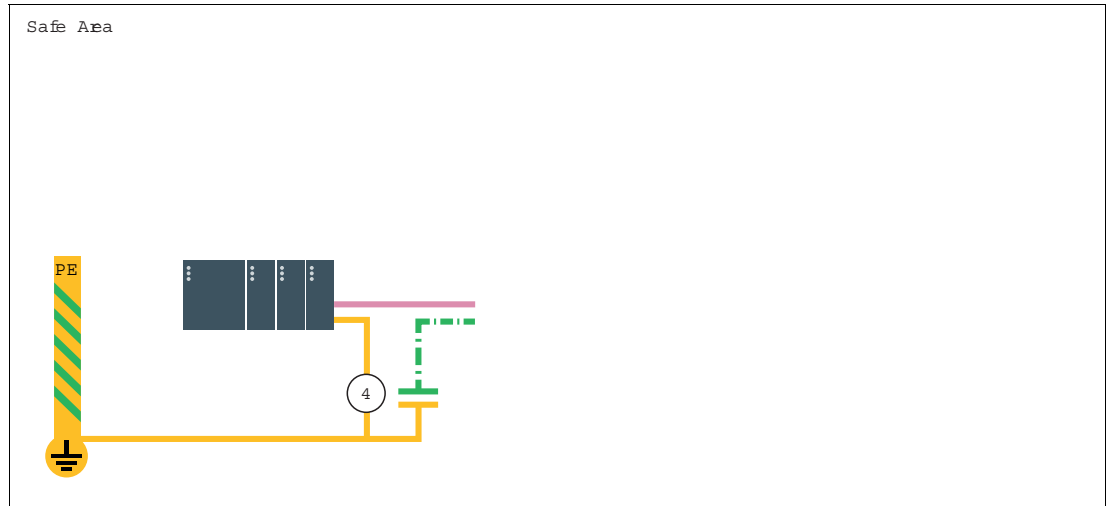

Figure 3.24 Schematic diagram

**Note**

Make sure that there is no connection between the protective grounding (PE) and the equipotential bonding (PB) via the PLC.

From the perspective of electromagnetic compatibility (EMC), this type of grounding acts as a grounding on both sides, since the high-frequency part of the interference is dissipated via the capacitor. However, from the point of view of explosion protection, this installation method behaves like the examples described for the respective bus system in step 4 in Chapter (see chapter 3.14.3.2). Therefore, all the requirements listed therein must be met. In particular, the capacitor must be considered as additional equipment that must meet the requirements of the system, such as nominal voltage, air and creepage distances, high voltage strength, etc.

**Note**

In addition, confirmation from a qualified person for the hazardous area must be obtained for this type of installation **in each individual case**.

3.14.3.4 Double-Sided Grounding of the Fieldbus Shield in Ethernet Bus Systems

For Ethernet gateways of type LB812*, capacitor Y2 is already included in the gateway and can therefore be used for the capacitive isolation of protective grounding (PE) and equipotential bonding (PB), as already described in the previous chapter (see chapter 3.14.3.3).



Laying the cable shield for Ethernet bus systems

1. Connect the PB terminals of the backplane to the PB rail (2).



Note

In the case of previously supplied backplanes, the PB terminals are marked with PE, but are technically equivalent and therefore treated as PB terminals in the following.

2. Connect the field signal shield bar (1) to the PB rail (2).
3. Connect the communication cable to the gateway using the pre-assembled RJ45 plug.

↳ The cable shield is therefore connected via the RJ45 socket to capacitor Y2 in the gateway and to the equipotential bonding (PB) on the backplane (for Y2 capacitor, see position 4 in the figure below).

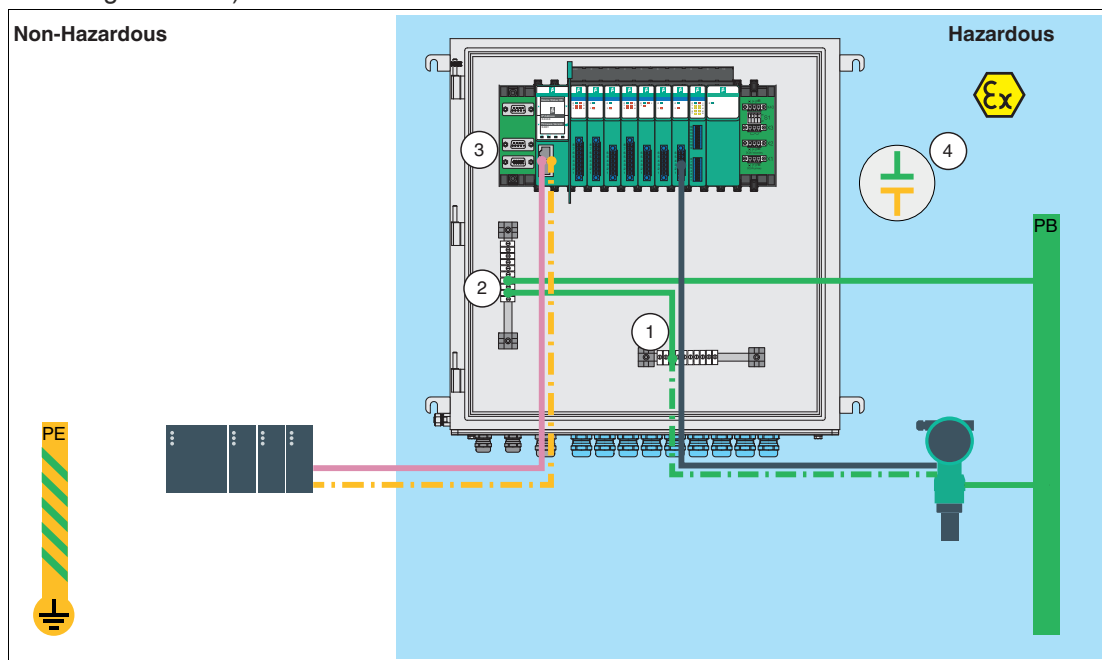

Figure 3.25 Principle representation

3.14.4 System Expansion

Adding I/O Modules

By adding an I/O-module, input or output data will be transferred to a slot that was previously empty. To do this, the configuration of the com unit must be adapted. Changes to the configuration of the com unit usually result in the function being interrupted due to a fieldbus restart.

To avoid this, you can activate Hot Configuration in Run (HCiR) in the com unit. If HCiR is active, a new configuration can be transferred to the com unit in the form of a passive data record. In this way, the master still has access to the old configuration in its existing form. As soon as the new configuration in the master matches the new configuration in the com unit, the new configuration in the com unit is activated and the old configuration is deleted. For more information, refer to the software manual for the com unit used.

Alternatively, you can use the Unicom com unit LB8109*. Using the Unicom com unit, you can configure the slots on the backplane in such a way that they can later be used with different I/O modules. For more information, refer to the software manual for Unicom com unit LB8109*.

Extending the Fieldbus

In order to extend the fieldbus cable, the terminator must be removed. In this case, operation can only be maintained using a redundant system.

3.15 Connection Ethernet-based Fieldbuses



Danger!

Explosion hazard from improper installation

Improperly installed fieldbuses can cause explosive mixtures to ignite.

Observe the wiring specifications set out in IEC/EN 60079-14 for laying lines in a hazardous area.



Danger!

Explosion hazard from impermissible accessories

Accessories that do not meet the requirements for use in hazardous areas can cause explosive mixtures to ignite.

Only use accessories and devices that are approved for use in the respective environment.

Connection type	RJ45 , via front socket
Transfer rate	10BASE-T, 100BASE-TX 100 MBit/s
Cable type	SFTP according to ISO/IEC 11801 for Cat-5e or better
Bus length	max. 100 m per link

Assembling the RJ45 connector

If you do not have a ready-made cable with the right length for your installation conditions, you can also customize the cable yourself by using a ready-made RJ45 connector.

The Pepperl+Fuchs type **V45-G** is suitable for this purpose. You can also choose from a wide range of suitable connectors from other manufacturers.

When assembling, pull off a piece of the outer sheath at the end of the cable by making a flat cut in the sheath with a suitable tool (e.g. cutter). Then move the cutter around the cable so that the jacket can be easily pushed off. This will expose twisted cables, each in a different colour or colour combination.

Insert the wires into the RJ45 connector and make sure they stay aligned and each color goes into the correct channel.

Use a professional tool to crimp the RJ45 connector to the cable by pressing the sheath and the cable into the connector.

System Information

The gateway can only be installed with the following backplanes in zone 2 or outside the explosion-hazardous area.

Type designation	Function	Slots for I/O modules	Slots for power supply units
LB9023BP08110.1	Basis backplane	8	1
LB9029BP12320.1	Basis backplane	12	3
LB9026BP16210.1	Basis backplane	16	2
LB9022BP22320.1	Basis backplane	22	3
LB9025BP08100.1	Extension Backplane	8	1
LB9027BP16200.1	Extension Backplane	16	2
LB9024BP24300.1	Extension Backplane	24	3



Note

Separation Wall Between Ethernet based Gateways and I/O Modules

Note that a clearance of 50 mm must always be maintained between intrinsically safe and non-intrinsically safe circuits. Therefore the separating wall (LB9182A) must be installed between the gateway (LB81xxA.1.EL) and the I/O modules. If only non-intrinsically safe circuits with Ex ic modules are used and the LB module is marked accordingly, e.g., by deleting Ex ic on the module markings, the partition is not necessary.

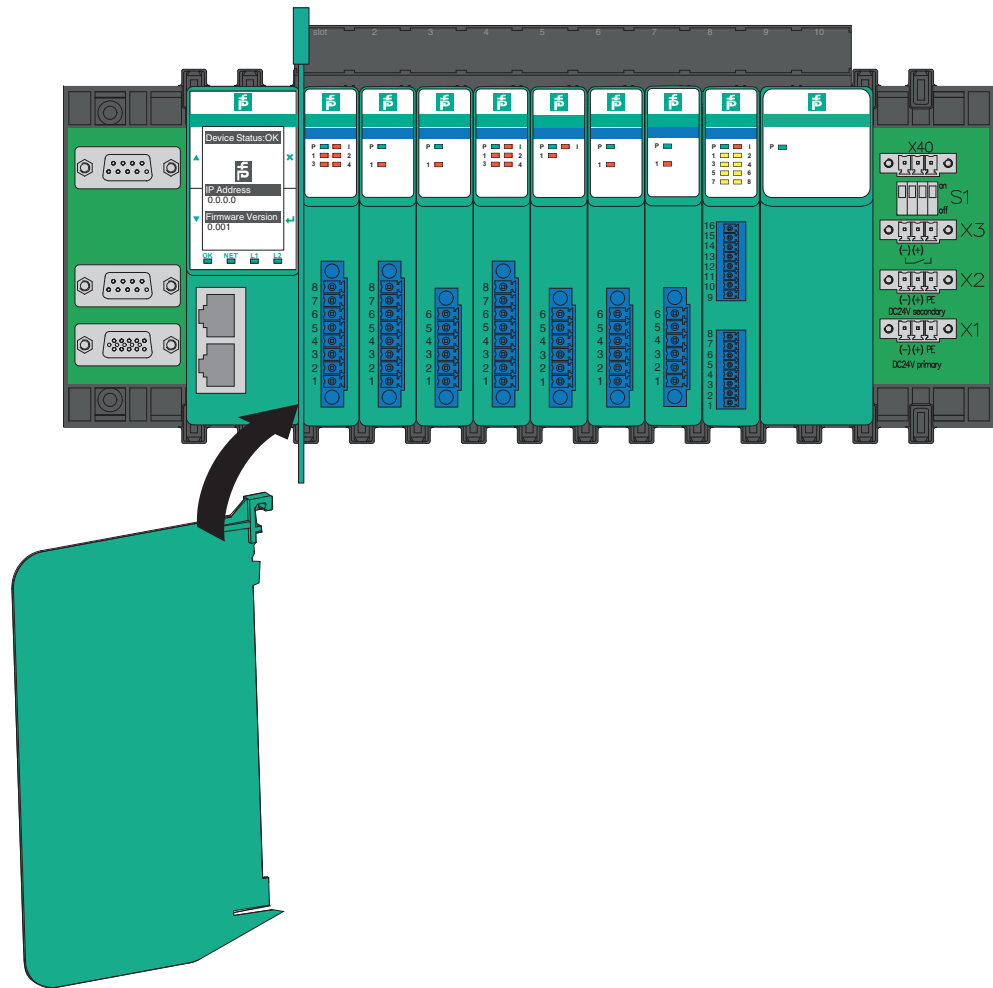

Figure 3.26 Separation wall

For the use of the module in explosion-hazardous areas (e.g., Zone 2 or Div. 2) a suitable enclosure is required. For further details, refer to the EC-Type Examination Certificates, Statements of Conformity, Declarations of Conformity, Certificates of Conformity and Operating Instructions. This information can be found at www.pepperl-fuchs.com.

4 Commissioning

4.1 Commissioning of RS 485 based Fieldbuses



Danger!

Explosion hazard

When work is performed on the remote I/O unit in explosion-hazardous areas, there is a risk of explosion from spark formation.

Work must be performed with a hot work permit only, in other words when there is no potentially explosive atmosphere.

4.1.1 Electrical Testing of Connections

Make sure that the terminators have been properly fitted to the fieldbus and the service bus.



Test of Physical Connection Right to the End of the Segment



Tip

Perform the measurements from the control room.

1. Disconnect the bus connector from the master.
2. Deactivate the terminator on the bus connector (bus start).
3. Measure the voltage at the bus connector between A (pin 3) and B (pin 8).
 - ↳ A voltage of $U = 220 \Omega / (220 \Omega + 2 * 390 \Omega) * 5 \text{ V} = 1.1 \text{ V}$ must be present between A and B. This voltage comes from the field-side terminator.
 - If the 1.1 V voltage is not present, there is either no terminator connected at the end, the cable is faulty, or there is no terminating voltage at the remote I/O station.
4. Measure the current at the bus connector between A (pin 3) and B (pin 8).
 - ↳ It must be possible to measure a current of $I = 5 \text{ V} / (2 * 390 \Omega) \approx 6.4 \text{ mA}$ between A and B.
 - If the current is significantly higher, by a factor of 2 or more, the bus is terminated using more than one terminator.
 - If the current is $I \approx 0 \text{ mA}$, then either there is no terminator present, the cable is faulty, or there is no terminating voltage. In this case, a resistance of 220Ω should be measured between A and B.
 - If no current or resistance can be measured, the terminator at the end of the bus is missing or the cable is faulty.
5. Activate the terminator on the bus connector for the master.
6. Plug the bus connector back into the master.



Test of Physical Remote I/O Station Connection



Danger!

Risk of explosion

When taking measurements in hazardous areas, there is a risk of explosion from sparks forming.

Take measurements on the terminal connections of a remote I/O station, with a hot work permit only, in other words when there is no potentially explosive atmosphere.

1. Disconnect the bus connector from the master.
2. Deactivate the terminator on the bus connector (bus start).
3. Measure the voltage between A (pin 3) and B (pin 8) on the bus connection of each remote I/O station.
↳ A voltage of $U = 1.1 \text{ V}$ must be present between A and B on each remote I/O station.
4. Activate the terminator on the bus connector for the master.
5. Plug the bus connector back into the master.

4.1.2 Configuration

The entire remote I/O station is configured via the com unit. Communication with the com unit can be set up via either the fieldbus or the service bus.



Note

The LB8107* com unit can be configured via the service bus only.

For more information, refer to the software manual for the com unit used.

Service Bus Connection via RS-232



Danger!

Explosion hazard

When work is performed on the remote I/O unit in explosion-hazardous areas, there is a risk of explosion from spark formation.

Work must be performed with a hot work permit only, in other words when there is no potentially explosive atmosphere.

The W&T; RS-232-RS-485 interface converter can be connected to the remote I/O unit using either a preassembled or self-made cable. You can order the preassembled cable together with the W&T; RS-232-RS-485 interface converter from Pepperl+Fuchs.

Use the following wiring diagram if you intend to make your own cable.

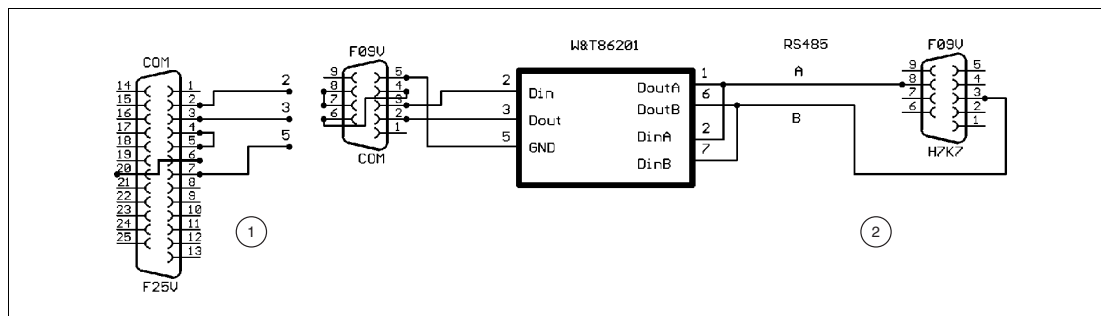

Figure 4.1 Wiring diagram for W&T; RS-232-RS-485 interface converter

- 1 Connection side PC
- 2 Connection side Remote I/O

Service Bus Connection via USB



Connecting the USB Converter to the PC

1. Install the driver that accompanies the USB-RS-485 converter.
2. Connect the USB converter to any USB port on the PC.

↳ The hardware wizard automatically detects and installs a new USB device. The converter is listed under connections in the hardware manager COM port list. The COM port to which the converter was assigned can be seen in this list. The COM port in use can be modified via the same entry in the device manager if required (**Properties** context menu).

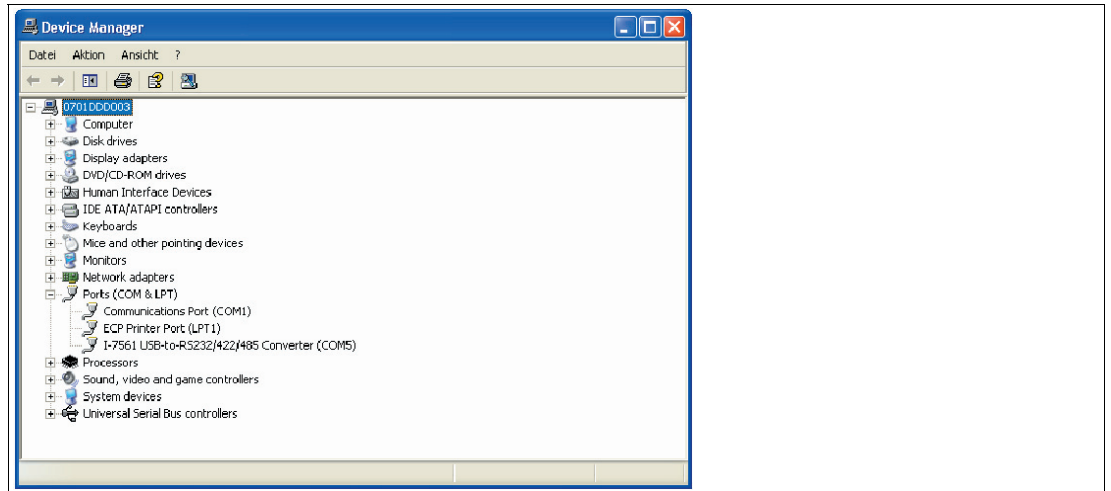

Figure 4.2 USB converter in device manager

4.1.3 Startup Phase

Do not start to operate all the remote I/O stations simultaneously; instead, connect each remote I/O station to the master in succession.

Ensure that the master read cycle and the com unit watchdog are coordinated with one another. The duration for the transition to substitute values must be longer than the duration of a bus cycle.

For the purposes of fault analysis, we recommend using a bus monitor that is capable of passively monitoring data telegrams on the fieldbus.

4.2 Commissioning of Ethernet based Fieldbuses

A commissioning includes the integration of the LB-Remote-I/O-System into a communication network. For commissioning you need the IP address and the name of the gateway. After assigning the name via the configuration software, the gateway is addressable for a controller.

For further details refer to the software manual for the corresponding bus protocol.

5

Operation



Danger!

Risk of explosion

If I/O modules are hot swapped, there is a risk of explosion due to sparks forming, since the connections on the backplane are not intrinsically safe.

Before replacing I/O modules, make sure that the atmosphere is not potentially explosive, e.g., by obtaining a hot work permit.

During operation, you can access up-to-date measured values and diagnostic information for the I/O modules via the gateway resp. com unit. For more information, refer to the software manual for the gateways resp. com unit used.

In addition, you can read off basic information about supply and communication from the LEDs on the I/O modules and com units/gateways. For more information about the LEDs, refer to the data sheets for the I/O modules and com units/gateways used.

6 Troubleshooting

6.1 Troubleshooting of RS 485 based fieldbuses



Danger!

Risk of explosion

When work is performed on the remote I/O unit in hazardous areas, there is a risk of explosion from spark formation.

Before starting any work on the remote I/O unit, familiarize yourself with the instruction manuals for the components and their relevant certificates.

Communication Errors

Error	Remedy
Communication error on the fieldbus	<ul style="list-style-type: none"> • Check that the cables are connected. • Check that the transmitting and receiving lines are wired correctly and have not been swapped. • Check that the nodes are positioned in linear form and without branches. A star-shaped layout is not permitted. • Check that the terminator has been activated. The fieldbus must have exactly two terminators per segment, one at the start and one at the end. • In the configuration software, check that the selected address is the same as the remote I/O station address. • In the configuration software, check whether the master read cycle and the com unit watchdog are coordinated with one another.
Communication error on the service bus	<ul style="list-style-type: none"> • Check that the cables are connected. • Check that the nodes are positioned in linear form and without branches. A star-shaped layout is not permitted. • Check that the terminator has been activated. The service bus must have exactly two terminators per segment, one at the start and one at the end. • In the configuration software, check that the selected address is the same as the remote I/O station address. • Check that the correct interface is preset in the configuration software.
Communication error on the service bus after successfully establishing a connection	<ul style="list-style-type: none"> • Check that the service bus is galvanically isolated. • If you are using a laptop, operate the laptop using a battery. • Use a standard interface converter (RS-232 to RS-485 converter or USB to RS-485 converter) with automatic detection of the baud rate and transmission direction.
A new remote I/O station will not work on a bus if other remote I/O stations are already operating on the bus.	<ul style="list-style-type: none"> • Check that the terminators are still on the start and end of the bus after expansion.
The software cannot locate a com unit when establishing the connection	<ul style="list-style-type: none"> • Check that the com unit is plugged in correctly.

Redundancy Faults

Fault	Remedy
Continuous redundancy switchover	<ul style="list-style-type: none"> Check that the correct type of redundancy is selected (media redundancy or application redundancy). In the configuration software, check whether the master read cycle and the com unit watchdog are coordinated with one another. Check that the process control system is set to the correct type of redundancy.
No redundancy switchover when a com unit is removed	<ul style="list-style-type: none"> Check that redundancy has been configured at the com unit. Check that there is an electrical connection between the two com units. If not, establish a connection.
I/O modules are continuously changing the data	<ul style="list-style-type: none"> Check whether one of the com units has not been configured for redundancy mode. If this is the case, both com units actively try to access the I/O modules and interfere with one another.

Signal Faults

Fault	Remedy
Faulty signal	<ul style="list-style-type: none"> Check whether the I/O module is in simulation mode or whether it is working with substitute values. Check if there is a short circuit or lead breakage within the circuit. Check that the field devices and sensors are working properly. Check the communication path to the I/O module. If necessary, replace the I/O module.
All signals for a station are faulty	<ul style="list-style-type: none"> Check that the power supply is working properly. Check the bus connection. Check the bus communication using a bus monitor.
The output module switches off	<p>Communication with the com unit is interrupted.</p> <ul style="list-style-type: none"> Check that the I/O module is plugged into the backplane properly. If necessary, switch off the status bits for analog outputs in the configuration software.
Input module sporadically delivers no measured values	<p>Communication with the com unit is interrupted.</p> <ul style="list-style-type: none"> Check that the I/O module is plugged into the backplane properly.
Measured values occasionally incorrect	<ul style="list-style-type: none"> Check whether the measured value is being distorted by external influences. Check that the shielding is intact.
I/O module reported to be faulty	<ul style="list-style-type: none"> Check that the correct I/O module is plugged in. Check that the green LED on the I/O module is lit and that the I/O module is correctly plugged in.

6.2 Troubleshooting of Ethernet based fieldbuses

A suitable cable must be used, see chapter 3.15.

Check that the cable connections are intact and that all communication components including the gateway are correctly plugged in and supplied with sufficient power.

Check the communication status using the gateway LEDs. Please refer to the software manual of the corresponding bus protocol for the further procedure.

Your automation, our passion.

Explosion Protection

- Intrinsic Safety Barriers
- Signal Conditioners
- FieldConnex® Fieldbus
- Remote I/O Systems
- Electrical Ex Equipment
- Purge and Pressurization
- Industrial HMI
- Mobile Computing and Communications
- HART Interface Solutions
- Surge Protection
- Wireless Solutions
- Level Measurement

Industrial Sensors

- Proximity Sensors
- Photoelectric Sensors
- Industrial Vision
- Ultrasonic Sensors
- Rotary Encoders
- Positioning Systems
- Inclination and Acceleration Sensors
- Fieldbus Modules
- AS-Interface
- Identification Systems
- Displays and Signal Processing
- Connectivity

Pepperl+Fuchs Quality

Download our latest policy here:

www.pepperl-fuchs.com/quality

