

INSTRUCTION MANUAL

Ultrasonic Double Sheet Metal Monitor

UDCM-30GM-085-...

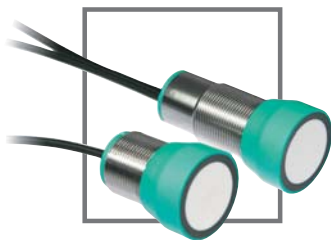

CE

1	Description of the sensor functions.....	3
2	Principle of operation	3
3	Measuring system.....	4
4	Installation and alignment.....	4
4.1	Avoidance of multiple reflections.....	5
4.2	Using a number of UDCM.....	6
5	Commissioning and parameter assignment.....	7
5.1	Connections.....	7
5.2	Normal operation.....	7
5.3	Output pulse expansion	8
5.4	Display mode.....	8
5.5	Parameter assignment.....	8
5.5.1	Programs.....	9
5.5.2	Parameter assignment procedure	9
5.6	Modes.....	10
5.6.1	Alignment aid.....	10
5.6.2	Program selection.....	10
6	Notes:	11
7	Technical data	12
7.1	Electrical connection.....	13
7.2	Dimensions.....	14
8	Accessories	15
9	Notes	16

Hints

These operating instructions provide information on how to use the product properly. They must be read and observed by all persons who use or work with this product. This product is only able to perform the functions for which it was designed if it is used and operated in accordance with information provided by Pepperl+Fuchs.

The warranty assumed by Pepperl+Fuchs for this product is null and void if it is not used and operated in accordance with its proper use as described by Pepperl+Fuchs

Changes to the devices or components and the use of defective or incomplete devices or components are not permitted. Repairs to devices or components may only be performed by Pepperl+Fuchs or authorized work shops. These work shops are responsible for acquiring the latest technical information about

Pepperl+Fuchs devices and components. Repair tasks made on the product that are not performed by Pepperl+Fuchs are not subject to influence on the part of Pepperl+Fuchs. Our liability is thus limited to repair tasks that are performed by Pepperl+Fuchs.

The preceding information does not change information regarding warranty and liability in the terms and conditions of sale and delivery of Pepperl+Fuchs.

Subject to technical modifications.

Symbols used

This manual uses symbols to present important information on operating and working safely with the ultrasonic double sheet detection. The meaning of these symbols is as follows:



Note

Recommendation for the user

Observing this information will make it easier to place the ultrasonic double sheet detection in operation and work with it.



Attention

This symbol warns the user of possible improper functionality. Failure to heed this warning may result in complete failure of the equipment or other devices that are connected.

1 Description of the sensor functions

The ultrasonic double sheet detection sensor is used wherever the automatic distinction has to be made between the presence of a single or double sheet, in order to protect machinery and/or to avoid scrap. The double sheet control is based on the ultrasonic through-beam principle. The beam detects either:

- No sheet, i.e. air,
- a single sheet,
- or a double sheet or multiple sheets, where it is not possible to distinguish the number of sheets.

The evaluation is made using a microprocessor system. The corresponding switch outputs are set as a consequence of this evaluation. Changing ambient conditions, such as temperature and humidity, are compensated automatically.

2 Principle of operation

The principle on which double sheet detection is based is the measurement of the amplitude of the sound passing through the sheet. When no sheet is present, no sound is absorbed - and the received signal reaches a maximum. With two sheets lying one on top of the other, the multiple reflection of the sound between the two layers causes nearly all the sound energy to be absorbed and the amplitude of the received signal falls to a minimum. In principle, the thicker and/or denser the sheets, the lower is the proportion of sound that is transmitted. It is for this reason that the function of double sheet detection of different types of sheet is restricted to a specific range. If the sheets are too thin, too much sound is able to pass through them, so that the difference compared to the passage of the sound through air is too small and on the other hand, if the sheets are too thick, the attenuation of the sound is so great, that the amplitude for a single sheet lies in the same range as that for two sheets.

In fact 4 programs are available to the user for the various material spectra, with which he can optimally adjust the sensor to his particular application. The procedure of teaching in the single sheet can be completely dispensed with. This increases the user-friendliness of the device. Fluttering of the sheet does not affect the reliable function of the UDCM.

3 Measuring system

The complete device comprises an ultrasonic transmitter unit and a receiver and evaluation unit. The sensor heads are optimally adjusted to each other before they leave the factory and therefore must not be used separately or replaced with other devices of the same type. The plug connection on the transmitter/receiver connection cable merely serves the purpose of simplifying installation.

4 Installation and alignment

The perfect function of the sensor is only guaranteed if the centerlines of the transmitter and receiver are aligned exactly with each other. This is assured by using the mounting accessory MH-UDB-02 (see section 8 "Accessories" on page 15) (see Chapter 8 "Accessories" on page 15). In addition, the UDCM-30GM-085-... offers an electronic alignment aid (see section 5.6.1 "Alignment aid" on page 10) (see Chapter 5.6.1 "Alignment aid" on page 10), which is not a substitute, however, for the precise mechanical alignment of the sensor heads.

Recommended separation
between the sensor heads:

$$d = 50 \text{ mm} \dots 150 \text{ mm}$$

Angular misalignment:

$$\alpha < \pm 1^\circ$$

Maximum offset:

$$s < \pm 1 \text{ mm}$$

(see fig. 4.1 and fig. 4.2)

Recommended distances

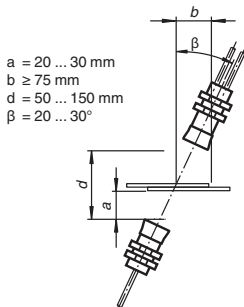
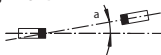

Fig. 4.1: Recommended separations and angular adjustments

Angular misalignment

$a < \pm 1^\circ$



Sensor offset

$s < \pm 1 \text{ mm}$



Fig. 4.2: Max. permissible misalignment of the sensor heads

To function correctly in double sheet detection the sensor heads must be aligned at right angles to the surface of the sheet - see fig. 4.1.

The sheet should pass above the sensor and at a distance of $a = 20 \text{ mm} \dots 30 \text{ mm}$ above it - see fig. 4.1.

To avoid the accumulation of dust deposits the transmitter is mounted underneath the sheet, so that the transmitter always transmits upwards. A self-cleaning effect is provided by the ultrasonic signal. The sensor head itself is secured with the nuts provided.

The sound cone must be completely covered by the sheet. This means that the sensor heads must be mounted at least $b = 75 \text{ mm}$ from the edge of the sheet (see fig. 4.1). The direction of transit of the sheet is of no significance.

4.1 Avoidance of multiple reflections

The ultrasonic double sheet detection operates at high sound levels. This is necessary for the reliable detection of sheets of various thickness up to approx. 3 mm. However, this feature presents the possibility of indirect sound propagation. When installing the UDCM, care should be taken that the ultrasonic signal cannot pass around the sheet that is to be detected, due to multiple reflections. This is a possibility if large surfaces causing reflection of the sound are present at right angles to the direction of propagation of the sound. This can be the case if unsuitable fixing devices are in use - see fig. 4.3 or if assemblies presenting a large surface area are a feature of the plant or machine in the application - see fig. 4.4. In the case of reflecting assemblies, these must either be covered with sound-absorbing material or an alternative mounting location must be found for the UDCM.

A ideal method of mounting is provided by the mounting accessory MH-UDB-02.

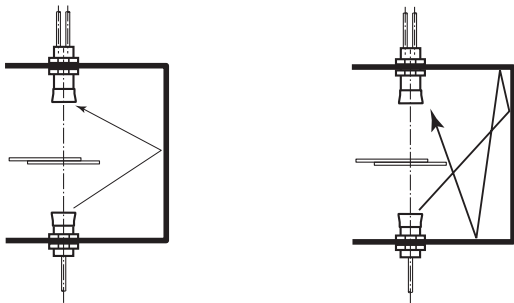

Fig. 4.3: Indirect sound propagation due to reflection on the mounting bracket

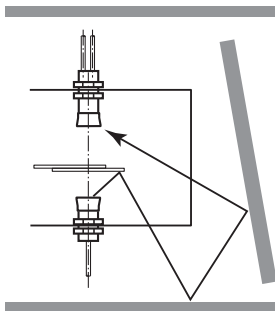

Fig. 4.4: Indirect sound propagation due to reflection on plant components

4.2 Using a number of UDCM

If a number of UDCM are to be operated in close proximity to each other, then acoustic isolation should be provided to avoid mutual interference. This can be provided, for example, by appropriately positioned isolating panels.

5 Commissioning and parameter assignment

5.1 Connections

The sensor has 6 connections. The functions of the connections are listed in the following table. The function input (core color pink, PK) is used to align the sensor and assign parameters to it. The following functions are available:

- Alignment aid
- Program selection
- Output pulse expansion

During operation the function input must always be securely connected to $+U_B$ or $-U_B$, so that any faults or error functions are avoided.

Color	Connection	Remarks
BN	$+U_B$	
WH	Switch output - Single sheet	Pulse width corresponding to the event
BK	Switch output - Double sheet	Pulse width corresponding to the event
GY	Switch output - Air	Pulse width corresponding to the event
PK	$-U_B/+U_B$	Function input for parameter assignment/pulse expansion
BU	$-U_B$	

5.2 Normal operation

The sensor operates in normal mode when the function input (PK) is connected to $-U_B$ or $+U_B$ when the supply voltage is applied (Power-On) - see corresponding table - Output pulse expansion (see section 5.3 "Output pulse expansion" on page 8).

Displays:

Yellow LED: Air detected

Green LED: Single sheet detected

Red LED: Double sheet detected

Switch outputs:

The switch outputs are only active in normal operation!

White: WH output -single sheet

Black: BK output - double sheet

Grey: GY output - air

5.3 Output pulse expansion

By connecting the function input (PK) to $-U_B$ or $+U_B$ a minimum pulse width of 120 ms can be selected for all output pulses of the three switch outputs.

Connection (PK)	Switch behavior (after Power-On)
$-U_B$	No output pulse expansion at the switch outputs
$+U_B$	Output pulse expansion at all switch outputs to at least 120 ms



Note

Depending on the time wise sequence of the application, the use of the output pulse expansion function can lead to the situation, in which more than one switch output is switched through.

5.4 Display mode

The default parameter assignment of the sensor can be displayed by switching the function input (PK) voltage-free during normal operation. The green LED displays the program number (number of flash pulses (1 ... 4) = Program number).

The outputs are inactive during this period.

If on application of the supply voltage (Power-On) the function input (PK) is switched voltage-free, then the sensor also operates in the display mode (the green LED flashes).

If during operation the function input (PK) is switched voltage-free due a fault (cable breakage, or cable loosened due to vibration), then the display mode provides a fault indication (the green LED flashes).

5.5 Parameter assignment

The sensor has 4 programs for different applications. This enables a wide range of materials to be detected. The user is able to select the program suitable for his application.

The standard setting program 1 has been selected such that for the majority of applications no adjustment is necessary.

5.5.1 Programs

Programmnumber	Remarks
1	Standard setting. Covers a wide spectrum of materials
2	Thickness, thick sheets
3	Thin sheets
4	Thinnest sheets, metal foils

5.5.2 Parameter assignment procedure

The other modes can be selected by cycling from the display mode:

- Alignment aid mode-->
- Program selection mode-->
- Alignment aid mode-->

Mode changeover is achieved by first connecting the function input (PK) to $-U_B$ (for > 500 ms). The next program step is selected within the "Program selection" mode by connecting the function input (PK) to $+U_B$ (for > 500 ms).

The current mode is exited with the selected program change by disconnecting the supply voltage.

The switch outputs are inactive during the parameter assignment of the sensor!

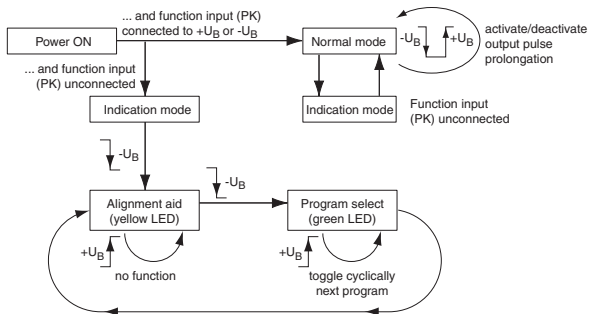

Fig. 5.1: Parameter assignment

5.6 Modes

5.6.1 Alignment aid

When installing the sensor the UDCM is able to provide an aid to secure the optimum alignment of the transmitter relative to the receiver.

If the sensor detects air (yellow LED lights), then after 3 seconds the UDCM starts to display the strength of the measured amplitude signal:

If there is a weak signal the yellow LED flashes at low frequency.

As the signal strength increases, so does the flashing frequency.

When optimum alignment is achieved (maximum signal strength) the yellow LED lights continuously.

The single sheet function (green LED) and double sheet function (red LED) are active from now on. The correct function of the double sheet detection can be verified in this way.



The use of the alignment aid function does not replace the correct mechanical alignment of the sensor heads.

The correct mechanical alignment of the sensor heads is indispensable for the reliable functioning of the UDCM!

5.6.2 Program selection

In the program selection mode the current program number is displayed by the green LED (number of flash pulses = program number). The next program in the cycle is selected by connecting PK to +U_B (for > 500 ms) (Program 1 switches to Program 4).

6 Notes:



Note

This sensor is not suitable for the detection of joint positions or labels. Pepperl+Fuchs is able to provide devices specially developed for these tasks.



Note

We recommend the use of the mounting accessory MH-UDB-02 for the correct alignment of the sensor heads.



Note

Very thin metal foils and perforated sheets are not always suitable for double sheet detection, due to their physical characteristics. Other materials that have to be excluded are those which themselves represent a double sheet, e.g. sheets welded together and folded or crimped over sheets.



Note

Due to the great variety of types of sheet, we strongly recommend that the type of application and the range of materials to be detected should be carefully investigated in the context of an approval procedure before the actual use of the sensor, so as to ensure optimum reliability of detection.



Attention

During operation the sheets must not come into contact with the sensor heads.

The installation, commissioning and maintenance of the devices must only be undertaken by qualified specialist personnel. The sensor heads must be carefully mounted. If the device is not used for its intended purpose the reliable operation of the double sheet detection cannot be guaranteed.

Intervention in and/or modification to the device itself are not permitted.

7 Technical data

General data	
Detection range	50 ... 150 mm, optimum separation: 80 mm
Transformer frequency	85 kHz
Displays/operating elements	
Green LED	Display: Single sheet detected
Yellow LED	Display: No sheet detected (Air)
Red LED	Display: Double sheet detected
Electrical data	
Operating voltage	18 ... 30 V DC , Ripple 10 %SS
No-load current I_0	< 200 mA
Input	
Input type	Function input 0 level: $-U_B \dots -U_B + 1V$ 1 level: $+U_B - 1V \dots +U_B$
Pulse duration	≥ 100 ms
Impedance	≥ 4 k Ω
Output	
Output type	UDCM-30GM-085-3E0: 3 Switch outputs npn, N.O. UDCM-30GM-085-3E1: 3 Switch outputs npn, N.C. UDCM-30GM-085-3E2: 3 Switch outputs pnp, N.O. UDCM-30GM-085-3E3: 3 Switch outputs pnp, N.C.
Rated operating current I_e	3 x 100 mA , short-circuit/overload proof
Voltage drop U_d	≥ 3 V
Switch-on delay t_{on}	approx. 30 ms
Switch-off delay t_{off}	approx. 30 ms
Ambient conditions	
Ambient temperature	0 ... 50 °C (273 ... 323 K)
Storage temperature	-40 ... 70 °C (233 ... 343 K)
Mechanical data	
Protection class	IP65
Connection	2 m, PVC cable 0.14 mm ²
Material	
Housing	Brass, nickel plated, plastic parts PBT
Transducer	Epoxy resin/hollow glass sphere mixture; Polyurethane foam
Mass	300 g

Tabelle 7.1: Technical data

7.1 Electrical connection

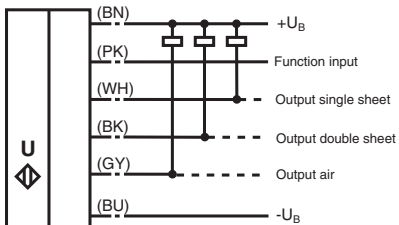

Fig. 7.1: Electrical connection, versions ...-3E0 and ...-3E1

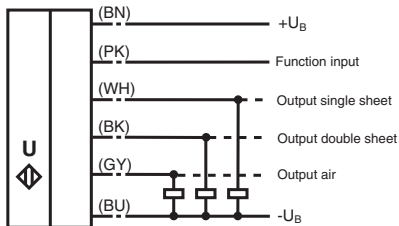

Fig. 7.2: Electrical connection, versions ...-3E2 and ...-3E3

7.2 Dimensions

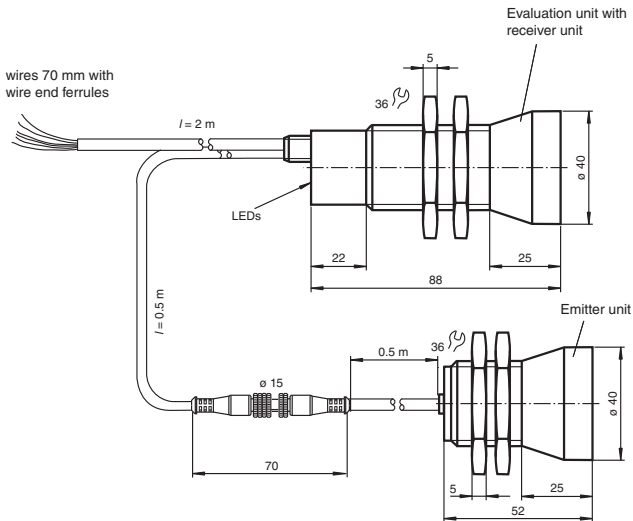

Fig. 7.3: Dimensions

8 Accessories

Mounting accessory: MH-UDB-02

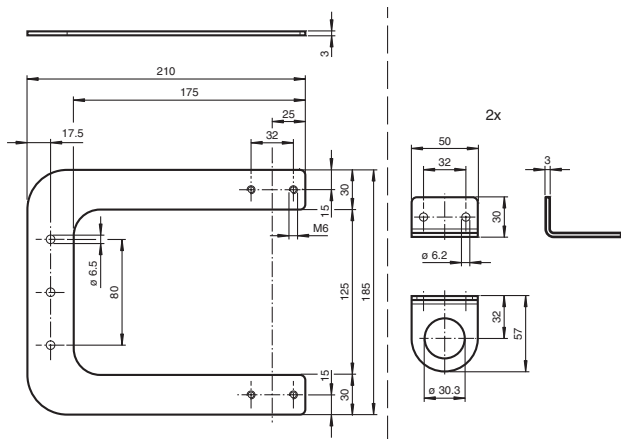

Fig. 8.1: Dimensions - Installation device MH-UDB-02

Extension cable, 1m: UDB-Cable-1m

Extension cable 2m: UDB-Cable-2m

9 Notes



Document No. DOCT-1185A

Part No. 199172

Issue date: 2012/03/19

FACTORY AUTOMATION – SENSING YOUR NEEDS



Worldwide Headquarters

Pepperl+Fuchs GmbH
68307 Mannheim · Germany
Tel. +49 621 776-0
E-mail: info@de.pepperl-fuchs.com

USA Headquarters

Pepperl+Fuchs Inc.
Twinsburg, Ohio 44087 · USA
Tel. +1 330 4253555
E-mail: sales@us.pepperl-fuchs.com

Asia Pacific Headquarters

Pepperl+Fuchs Pte Ltd.
Company Registration No. 199003130E
Singapore 139942
Tel. +65 67799091
E-mail: sales@sg.pepperl-fuchs.com

www.pepperl-fuchs.com

 **PEPPERL+FUCHS**
SENSING YOUR NEEDS