

MANUAL

**MODULAR SEGMENT
PROTECTOR
RM-SP***

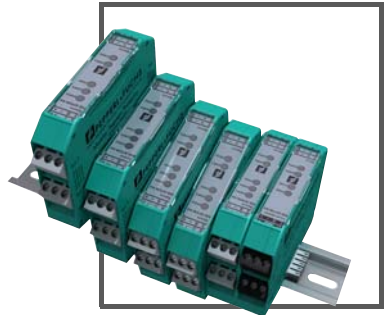

With regard to the supply of products, the current issue of the following document is applicable: The General Terms of Delivery for Products and Services of the Electrical Industry, published by the Central Association of the Electrical Industry (Zentralverband Elektrotechnik und Elektroindustrie (ZVEI) e.V.) in its most recent version as well as the supplementary clause: "Expanded reservation of proprietorship"

1	Safety	4
1.1	Validity	4
1.2	Symbols used	4
1.3	System Operator and Personnel	4
1.4	Pertinent Laws, Standards, Directives, and further Documentation	5
1.5	Delivery, Transport and Storage	5
1.6	Marking	5
1.7	Intended Use	5
1.8	Installation and Commissioning	6
1.8.1	Segment Protectors Special Mounting Requirements	6
1.8.2	Requirements Zone 2	6
1.8.3	Ex nL	6
1.9	Housing	7
1.10	Repair and Maintenance	7
1.11	Disposal	7
2	Product Specifications	8
2.1	Functional description	8
2.2	Device Component Overview	9
2.2.1	Status and error messages	9
2.3	Technical Data	10
3	Installation and Commissioning	11
3.1	Mounting	11
3.2	Demounting	13
3.3	RM-SPTM-N2 Connection Layout	14
3.4	RM-SPEM-N4 Connection Layout	15
3.5	Grounding / Shielding of Fieldbus Transmission Lines	16
3.6	Series Connection and Termination	17
4	Appendix	18
4.1	Ordering Information	18
4.2	Electromagnetic Compatibility Verification in Accordance with EC Council Legislation Directive 2004/108/EC	18
4.3	Referenced Documents	19

1 Safety

1.1 Validity

Specific process and instructions in this document require special precautions to guarantee the safety of personnel.

1.2 Symbols used

This document contains information that you must read for your own personal safety and to avoid property damage. The warning signs are displayed in descending order depending on the hazard category, as follows:

Safety-relevant symbols



Danger!

This symbol indicates a warning about a possible danger.

In case of ignoring the consequences may range from personal injury to death.



Warning!

This symbol indicates a warning about a possible fault or danger.

In case of ignoring the consequences may cause personal injury or heaviest property damage.



Caution!

This symbol warns of a possible fault.

In case of ignoring the devices and any connected facilities or systems may be interrupted or fail completely.

Informative symbols



Note!

This symbol brings important information to your attention.



Action

This symbol marks an acting paragraph.

1.3 System Operator and Personnel

The plant owner is responsible for its planning, installation, commissioning, operation, maintenance and disassembly.

Mounting, commissioning, operation, maintenance and dismantling of any devices may only be carried out by trained, qualified personnel. The instruction manual must be read and understood.

1.4 Pertinent Laws, Standards, Directives, and further Documentation

Laws, standards, or directives applicable to the intended use must be observed. In relation to hazardous areas, Directive 1999/92/EC must be observed.

The corresponding data sheets, declarations of conformity, EC Type-examination certificates, certificates and Control Drawings if applicable (see data sheet) are an integral part of this document. You can find this information under www.pepperl-fuchs.com.

1.5 Delivery, Transport and Storage

Check the packaging and contents for damage.



Check if you have received every item and if the items received are the ones you ordered.

Keep the original packaging. Always store and transport the device in the original packaging.

Always store the device in a clean and dry environment. The permitted storage temperature (see data sheet) must be considered.

1.6 Marking

The modules are product-specifically marked with:

RM-SPTM-N2	RM-SPEM-N4
Pepperl+Fuchs GmbH	Pepperl+Fuchs GmbH
68301 Mannheim/Germany	68301 Mannheim/Germany
Trunk Module	Extension Module
RM-SPTM-N2	RM-SPEM-N4
TÜV 11 ATEX 081152 X	TÜV 11 ATEX 081152 X
 II 3 G Ex nA [nL] IIC T4	 II 3 G Ex nA [nL] IIC T4

1.7 Intended Use

The RM-SP-N* Segment Protectors are couplers for fieldbus according to IEC 61158-2 to connect field devices through spurs to the trunk of a fieldbus segment. Each spur individually limits the current in case of a failure ensuring that the remaining segment is not affected.

The Segment Protector provides a certified Ex nL energy limitation at each spur connection.

The devices are only approved for appropriate and intended use. Ignoring these instructions will void any warranty and absolve the manufacturer from any liability.

The device must only be operated in the ambient temperature range and at the relative humidity (non-condensing) specified.

1.8 Installation and Commissioning

1.8.1 Segment Protectors Special Mounting Requirements

The device is designed for installation on a 35 mm DIN mounting rail in accordance with DIN EN 60715.

Take the cable parameters to be used from the installation instructions of the corresponding Fieldbus system and from the Statement of Conformity.

During installation of Segment Protectors, the following parameters must be strictly followed:

- The permissible core cross-section is 0.2 mm² to 2.5 mm².
- The insulation stripping length of strands is 7 mm.
- Whenever finely stranded conductors must be used, the strand ends must be protected from fraying, for example by using end splices.

The following identifying values must be observed when connecting Fieldbus transmission lines:

- Tightening torque for the screw terminals should be 0.5 ... 0.6 Nm.

The connectors are qualified for pulling and plugging at temperatures higher than -40 °C.

Within a segment, the physically last Segment Protector has to be equipped with a fieldbus terminator type M-FT.

1.8.2 Requirements Zone 2

Connection or disconnection of energized non-intrinsically-safe circuits is only permitted in the absence of a hazardous atmosphere.

The devices may only be installed and operated in zone 2 if they have been mounted in an enclosure with degree of protection IP 54 according to IEC/EN 60529. The enclosure must have a declaration of conformity according to 94/9/EC for at least category 3G.

Segment Protectors Zone 2 Special Requirements

Special care must be taken if power supply modules are to be used in conjunction with Pepperl+Fuchs segment protectors for energy limited Ex nL field wiring. A check must be made to ensure that the correct type of power supply module is used in relation to its output values. For example, the output voltage must be equal or less than the maximum voltage of the connected field devices.

Requirements for all used fieldbus products in Zone 2 installations are summarized in the manual: "Using Pepperl+Fuchs fieldbus equipment in Zone 2 hazardous area environment". This document is available separately.

1.8.3 Ex nL

Circuits of type of protection " Ex nL " (limited energy) that are operated with circuits of other type of protections must not be used as "Ex nL" circuits afterwards.

1.9 Housing

If additional housings are needed for installation in hazardous areas, the following points must be considered / evaluated:

- Degree of protection as per IEC/EN 60529
- Light resistance as per IEC/EN 60079-0
- Impact strength as per IEC/EN 60079-0
- Chemical resistance as per IEC/EN 60079-0
- Heat resistance as per IEC/EN 60079-0
- Electrostatics as per IEC/EN 60079-0

To ensure the IP degree of protection:

- all seals must be undamaged and correctly fitted
- all screws of the housing / housing cover must be tightened with the appropriate torque
- only cable of the appropriate size must be used in the cable glands
- all cable glands must be tightened with the appropriate torque
- all empty cable glands must be sealed with sealing plugs

1.10 Repair and Maintenance

The devices must not be repaired, changed or manipulated. If there is a defect, the product must always be replaced with an original device.

1.11 Disposal

Disposing of devices, packaging material, and possibly contained batteries must be in compliance with the applicable laws and guidelines of the respective country.

2 Product Specifications

2.1 Functional description

The Modular Segment Protector is a smart wiring interface for fieldbus distribution with short circuit protection at each output. It is designed for fieldbus systems according to IEC 61158-2 such as FOUNDATION Fieldbus H1 or PROFIBUS PA. Communication and power distribution share the same two-wire cable using Manchester Bus Powered (MBP) coding.

The modules of the Segment Protector can be snapped side-by-side on the DIN rail. A system plug which clips on the DIN-Rail interconnects individual modules. The fieldbus trunk is connected to the Trunk Module RM-SPTM-N2. It also provides two outputs for field devices named spurs. Extension Modules RM-SPEM-N4 add four spur connections each to the Trunk Module. Tailored solutions can easily be engineered and built. Segment extension is possible for a total of 26 Spurs per Trunk Module.

The Segment Protector is specifically suited for control cabinet installation. Any grounding and shielding concept is supported allowing optimal segment design. The Segment Protector is certified for installation in Zone 2.

Segment Protectors in conjunction with power supplies such as the basic power supply KLD2-FBPS-1.25.360 implement the High-Power Trunk concept. This concept enables maximum cable lengths and highest number of devices in any explosive area: The Segment Protector provides Ex nL energy limitation at each spur connection. Utilizing Segment Protectors, field devices can be installed in Zone 2 and maintained while the system is energized.

Field instrumentation is connected one per spur connection. Each spur is equipped with short-circuit current limitation at 58 mA. If a short circuit or overload should occur at a spur, the fieldbus trunk and all other field devices remain in operation. When the fault is repaired, the Segment Protector automatically resumes operation of the spur. This feature and the over voltage protection at 39 V make fieldbus segments extremely reliable.

A fieldbus terminator with high-availability circuitry is included with each Trunk Module. There is a well-defined place, the open trunk output connector at the last module on the segment where the terminator is installed. Termination is clearly visible to installation personnel. This design further increases availability of fieldbus in two ways: The connection is secured by screws; and proper termination resulting in good quality signal levels is ensured.

One LED each indicates bus communication activity, yellow and flashing – and power on the trunk, green. Each output is equipped with a red LED for indication of a short-circuit condition or fault at the spur. The Modular Segment Protector is best suited for cabinet installation and applications where frequent changes and modifications are expected. It protects fieldbus segments from short-circuit conditions at each spur and features energy limitation for hazardous area Zone 2. Electronic design further contributes to superior plant availability.

2.2 Device Component Overview

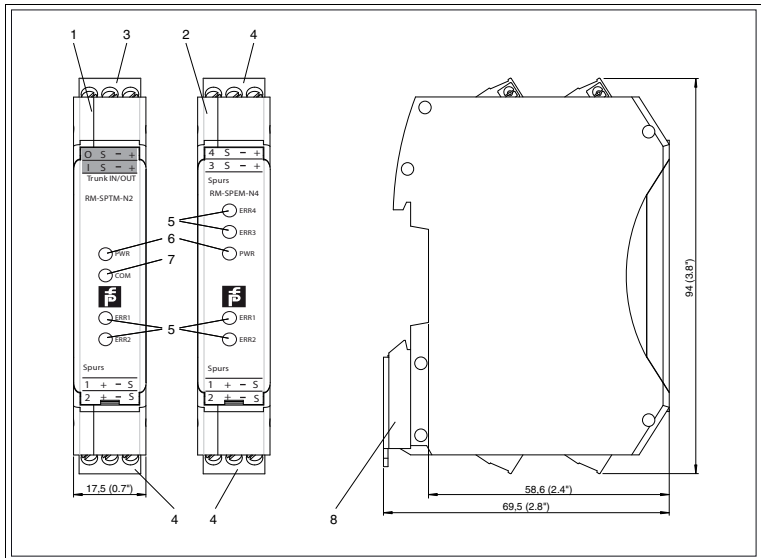

- 1 Trunk Module RM-SPTM-N2
- 2 Extension Module RM-SPEM-N4
- 3 Trunk connection
- 4 Spur connection
- 5 LED Spur (Error)
- 6 LED PWR (Power)
- 7 LED COM (Communication)
- 8 Fixing strap

All dimensions in millimeters (mm) and inch (") without tolerance indication

2.2.1 Status and error messages

LED ERR	Red, short-circuit
LED COM	Yellow flashing, bus activity
LED PWR	Green, Fieldbus Power present

2.3

Technical Data

	RM-SPTM-N2	RM-SPEM-N4
Fieldbus Interface		
Power loss typ.	0.2 W	0.1 W
Trunk:		
Rated Voltage	9...31 VDC	
Rated Current	≤ 4.5 A	
Spurs:		
Rated Voltage	31 VDC	
Rated Current	≤ 43 mA	
Short-circuit current	≤ 58 mA	
Current consumption typ.	7 mA	3.5 mA
Voltage drop trunk/spurs	≤ 1.3 V	
Terminator	100 Ohm external	
Surge protection:	Trunk overvoltage protection typ. 39 V, max. 41 V	
Ambient conditions	-40...70 °C (233...343 K)	
Operating temperature		
Storage temperature	-40...85 °C (233...358 K)	
Mechanical Data	Screw terminals, removable	
Connection type		
Core cross-section	≤ 2.5 mm ²	



Note!

For characteristic values in conjunction with hazardous areas, please refer to the data sheet



Note!

Calculations for Total System Values

Total power loss = 0.2 W + n * 0.1 W

Total current consumption = 7 mA + n * 3.5 mA

n = number of Extension Modules RM-SPEM-N4

3 Installation and Commissioning



Note!

Read chapter Safety see chapter 1, especially all relevant sections for your kind of use before performing any work.

3.1 Mounting

The mounting of the Modular Segment Protector is performed in two steps:

1. Preparing and mounting of the Bus Connector Modules.
2. Mounting of one Trunk Module and the several Extension Modules



Preparing and Mounting the RM-BP Bus Connector Module

1. Plug the Bus Connector Modules together.

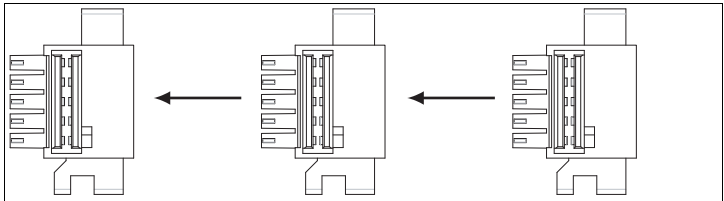

↳ Each Trunk and Extension Module requires one Bus Connector Module.

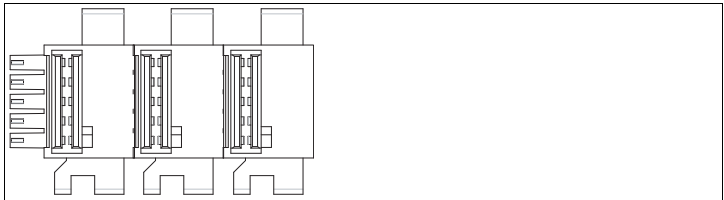

2. Attach the connected Bus Connector Modules to the DIN rail.

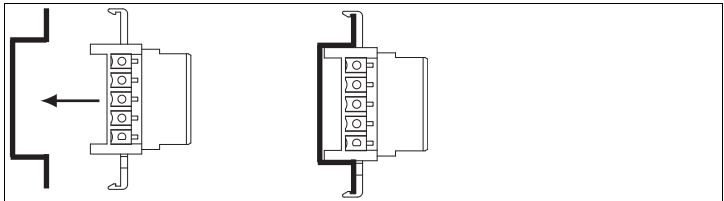

Dismounting is performed in the reverse order.

3.2

Demounting



Demounting the RM-SP*

1. Use a screw driver to loose the fixing trap and remove the module from the DIN rail.

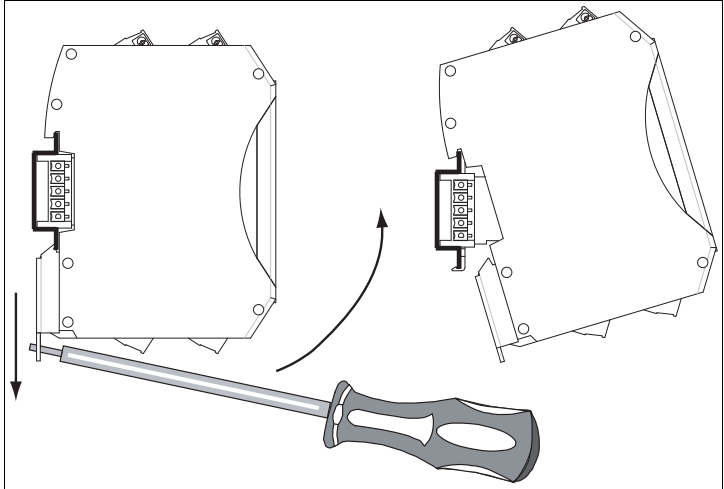

2. Repeat step 1 with all modules.



Demounting the RM-BP

Push the combined Bus Connector Moduls sideways out of the DIN rail.

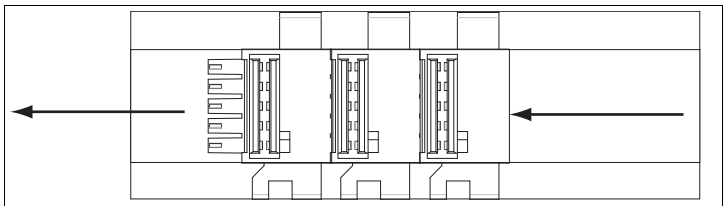

3.3 RM-SPTM-N2 Connection Layout

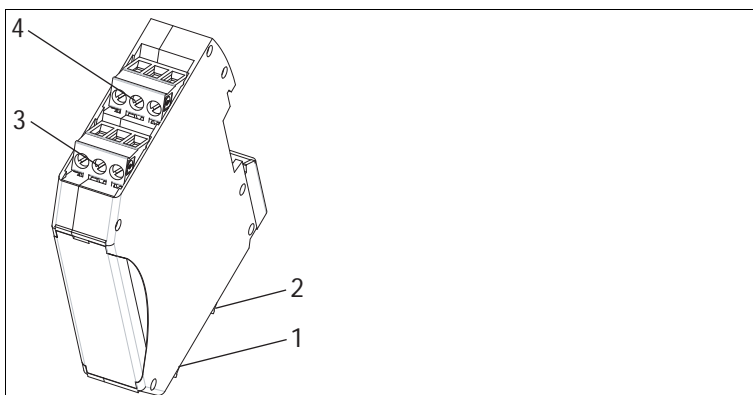

- 1 Spur Connection 1
- 2 Spur Connection 2
- 3 Trunk In Connection
- 4 Trunk Out Connection

Terminal Assignment

- S Shield connection
- Channel -
- + Channel +

3.4 RM-SPEM-N4 Connection Layout

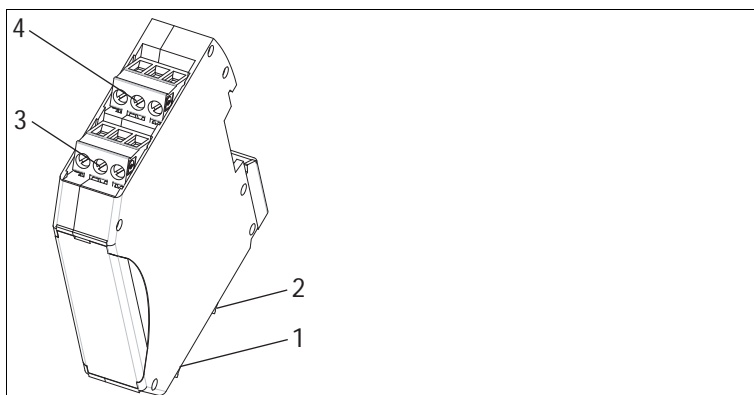

- 1 Spur Connection 1
- 2 Spur Connection 2
- 3 Spur Connection 3
- 4 Spur Connection 4

Terminal Assignment

- S Shield connection
- Channel -
- + Channel +

3.5 Grounding / Shielding of Fieldbus Transmission Lines

All shields of the Fieldbus transmission lines (trunks and spurs) are connected together inside the Segment Protector, they have no connection to ground/DIN rail.



Warning!

Wrong Wiring Practice

Connection of signal poles of the spur lines to the earth potential or the cable shield may cause major damage.

Do not connect any signal poles of spur lines to earth potential or cable shield.

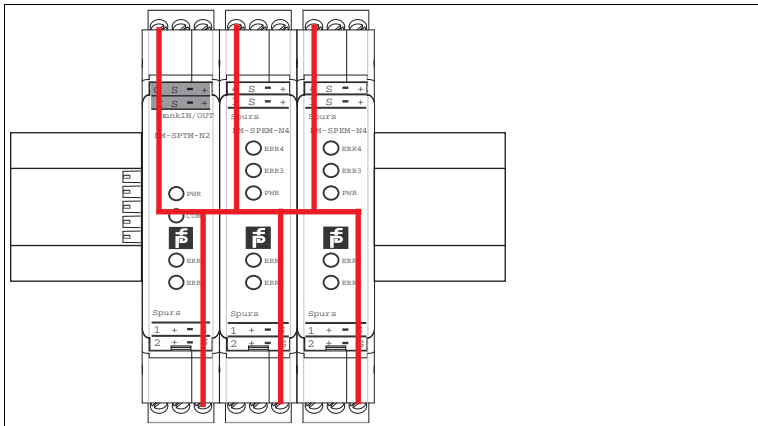

Figure 3.1: Stylized composition of the shield lines within the Segment Protector

If the shield of the trunk or of the spurs of a Fieldbus transmission line is grounded due to EMC considerations, the EN 60079-14 and the corresponding sections of the PROFIBUS PA User and Installation Guideline, or of the FOUNDATION Fieldbus Application Guides, should be closely observed.

3.6 Series Connection and Termination

The RM-SPTM-N2 Trunk Module offers two Trunk connection terminals on the devices' top side (Trunk in and Trunk out). This two connectors can be used to realize a series connection of several Segment Protector groups by connecting the Trunk line from one Trunk Module to the next one.

For good Termination practice a Fieldbus Terminator comes with each RM-SPTM-N2 Trunk Module which fits into a free Trunk terminal (mostly on the last Segment Protector within the row).

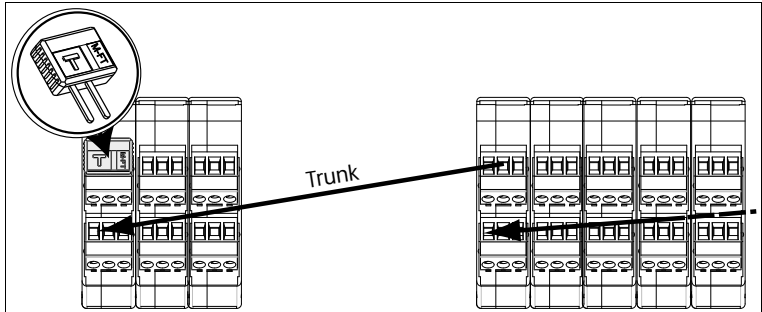

Figure 3.2: Stylized series connection and termination



Note!

As wrong termination may cause communication problems make sure that each trunk is terminated with exactly two Terminators.

4 Appendix

4.1 Ordering Information

Designation	Description
RM-SPTM-N2	Trunk Module
RM-SPEM-N4	Expansion Module
RM-BP	Bus Connector Module, (packaging unit = 3 pieces) One RM-BP comes with each Trunk Module RM-SPTM-N2 and Expansion Module RM-SPEM-N4
M-FT	Fieldbus Terminator M-FT, (packaging unit = 3 pieces) One Terminator comes with each Trunk Module RM-SPTM-N2

4.2 Electromagnetic Compatibility Verification in Accordance with EC Council Legislation Directive 2004/108/EC

Compatibility in accordance with EN61326-1:2006 and Namur NE21:2006 recommendation.

The electromagnetic compatibility – EMC – requirements applicable for electrical equipment for measurement, control and laboratory use in general are anchored in the European Standard EN 61326. Three different performance criteria are distinguished in this standard:

A category **A** device operates as intended during the test. This device can withstand the immunity tests without any noticeable performance degradations within the specification limits of the manufacturer.

A category **B** device operates as intended after the test. The device shows temporary degradation or loss of function of performance during the test but self-recovers from that state when the exposures are ceased.

A category **C** device has loss of function, may need manual restoration. During the test a temporary loss of function is allowed as long as an operator can restore the device back to operation.

The requirements of the association for standard and control and regulations of the German chemical industries, defined in the NE21 recommendation, are partly higher compared to the test levels and failure criteria defined in EN61326-1. For the product qualification, failure criteria and test levels have been selected, representing always the worst case conditions.

EN61000-4, as a generic standard, defines the test setups for the specific required test for EN61326-1 and NE21.

Applied standards:

- CE-Conformity 2004/108/EC
- EN61000-4, July 2007
- EN61326-1, October 2006
- EN55011, March 2007
- NE21, Mai 2006

Conducted EMC tests:

Immunity

Standard	Type	Test Level	Category
EN 61000-4-2	Electrostatic discharge, direct contact	6 kV	A
	Electrostatic discharge, indirect, air	8 kV	A
EN 61000-4-3	Electromagnetic field radiated, radio frequency	10 V/m	A
EN 61000-4-4	Fast transients burst on signal lines	1 kV	A
	Fast transients burst on power lines	2 kV	A
EN 61000-4-5	Slow transient surge on signal lines	1 kV	B
	Slow transient surge on shielded lines	2 kV	B
EN 61000-4-6	Conducted immunity, radio frequency	10 V	A
EN 55011	RF conducted emission	Class A	–
	RF radiated emission	Class A	–

4.3

Referenced Documents

- Manual: "Using Pepperl+Fuchs fieldbus equipment in Zone 2 hazardous area environment"

PROCESS AUTOMATION – PROTECTING YOUR PROCESS



Worldwide Headquarters

Pepperl+Fuchs GmbH
68307 Mannheim · Germany
Tel. +49 621 776-0
E-mail: info@de.pepperl-fuchs.com

For the Pepperl+Fuchs representative
closest to you check www.pepperl-fuchs.com/pfcontact

www.pepperl-fuchs.com

Subject to modifications
Copyright PEPPERL+FUCHS • Printed in Germany

 **PEPPERL+FUCHS**
PROTECTING YOUR PROCESS
200059 TDOCT-1215D_ENG

04/2010