

Guide for Selecting Flexible and Robust Glass Fiber Optics

Due to its own design and production, Pepperl+Fuchs is capable of providing you with the ideal fiber optics to suit your application. Choosing the perfect fiber optic takes only four simple steps! Please follow the guide.

Glass fiber optics from Pepperl+Fuchs for the VL18LL basic device start with the following designation in the type code:

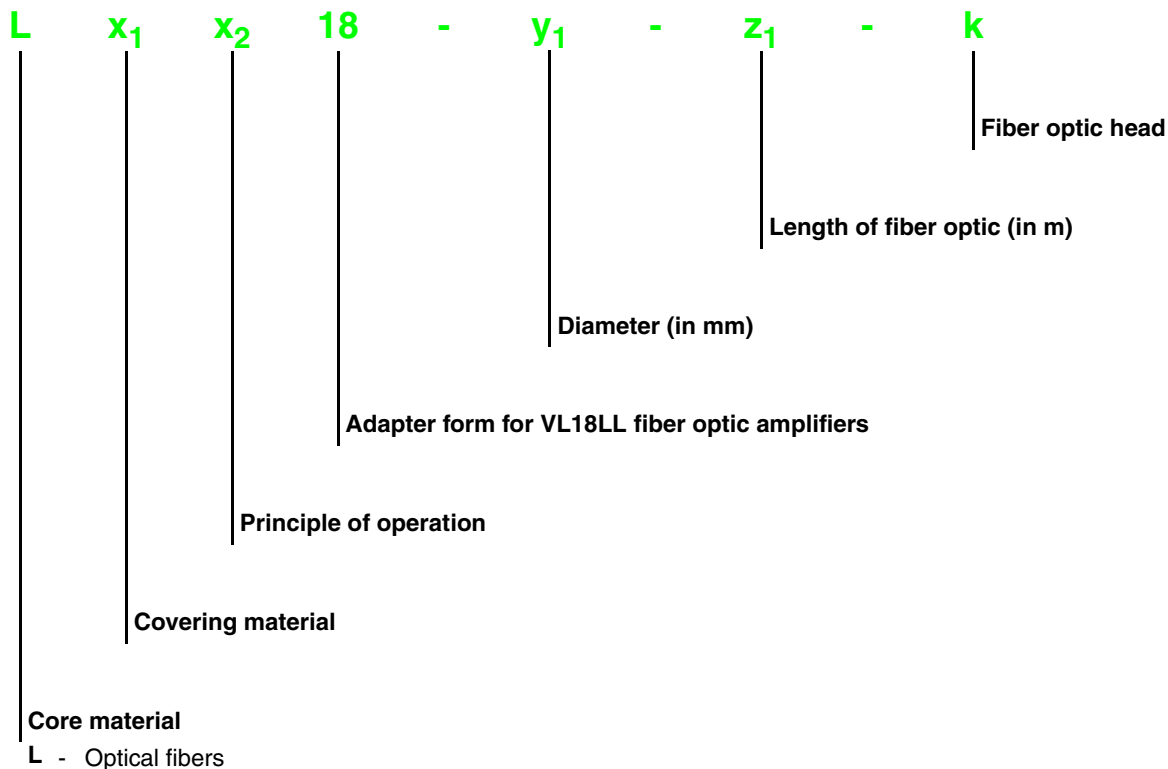

Step 1: Selecting the Principle of Operation **x₂**

Select the principle of operation and enter it for **x₂**.

- E** Thru-beam glass fiber optic for high ranges
- R** Diffuse glass fiber optic for easy mounting

e.g.:

L x₁ R 18 - y₁ - z₁ - k

Step 2: Selecting the Covering Material **x₁**

The given ambient temperatures and the required bending radii determine the preferred covering material. Select your required covering material and enter it for **x₁**.

Covering material	x₁	Max. temperature range	Min. bending radius
PVC	C	-20 °C ... 85 °C	10 ... 15 mm
Silicone	S	-40 °C ... 180 °C	15 ... 20 mm
Metal-silicone	L	-40 °C ... 180 °C	20 mm
Metal	M	-50 °C ... 200 °C	20 mm

e.g.:

LCE 18 - y₁ - z₁ - k

Step 3: Selecting the Required Range **y₁, z₁**

Please select the detection range you require.

There are differences between thru-beam glass fiber optic and diffuse fiber optic. Chose the principle of operation first. Your required detection range is used as the basis for calculating the values for the diameter **y₁** and length of fiber optic **z₁**.

z₁ Select the required length of fiber optic and enter it into the model number.

y₁ Determine the required fiber cross-section and enter it into the model number.

e.g.:

LCE 18 - 1.1 - 1.0 - k

Thru-Beam Principle of Operation:

Max. detection range when using the VL18LL fiber optic basic device:

		Max. detection range [mm]*			
		$Z_1 = 0.5 \text{ m}$	$Z_1 = 1 \text{ m}$	$Z_1 = 2 \text{ m}$	$Z_1 = 3 \text{ m}$
y_1	1.1	55	52	47	45
	1.6	100	95	92	90
	1.9	220	205	200	190
	2.3	300	296	292	285

Diffusion Principle of Operation:

Max. detection range when using the VL18LL fiber optic basic device:

		Max. detection range [mm]*			
		$Z_1 = 0.5 \text{ m}$	$Z_1 = 1 \text{ m}$	$Z_1 = 2 \text{ m}$	$Z_1 = 3 \text{ m}$
	0.8	variable	variable	variable	variable
y_1	1.1	7	6	5	5
	1.6	35	32	30	27
	1.9	variable	variable	variable	variable
	2.3	70	64	59	55

* Detection range measured on white



Note!

A diffuse mode fiber optic cable has a transmitter and receiver each fiber bundle.
 At a fiber bundle cross-section of 2.3 mm resulting in an total fiber bundle cross-section of 3.2 mm.
 At a fiber bundle cross-section of 1,9 mm resulting in an total fiber bundle cross-section of 2,7 mm.
 At a fiber bundle cross-section of 1,6 mm resulting in an total fiber bundle cross-section of 2,3 mm.

Step 4: Selecting the Fiber Optic Head_k

Select the desired design of the fiber optic head k , check the availability of the head with relation to the diameter y_1 and enter it into the model number.

e.g.:

LCE 18 - 1.1 - 1.0 - K3

Standard heads with thread:

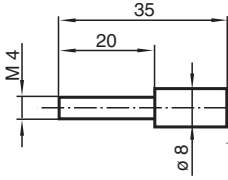
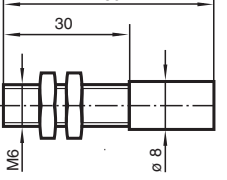
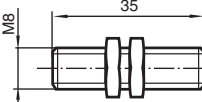
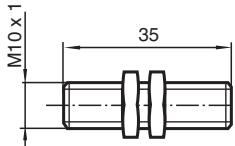
				
	M4 thread	M6 thread	M8 thread	M10 thread
K	K3	G	K5	K4
y_1	1.1	1.1	1.1	1.1
	1.6	1.9	1.9	1.9
	1.9 (thru-beam only)	2.3	2.3	2.3

Standard heads, cylindrical:

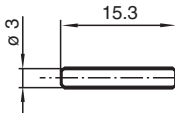
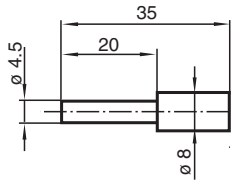
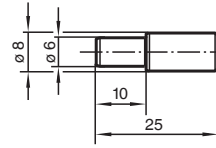
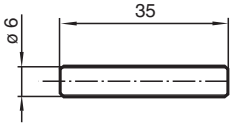
				
	Diameter 3 mm	Diameter 4.5 mm	Diameter 6/8 mm	Diameter 6 mm
K	15C3	K1	Z1	K7
y₁	1.1	1.1	1.1	1.1
	1.3 (thru-beam only)	1.6	1.6	1.6
	-	-	1.9	1.9
	-	2.3	2.3	2.3

* Available with silicone covering only

Standard heads with smooth right angle / thread:

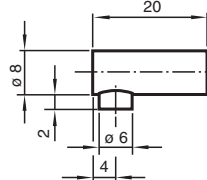
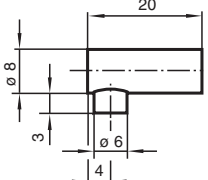
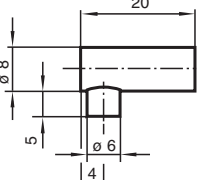
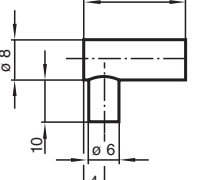
				
	Bar 2 mm	Bar 3 mm	Bar 5 mm	Bar 10/6 mm
K	WC2	WC3	WC5	WC10
y₁	1.1	1.1	1.1	1.1
	1.6	1.6	1.6	1.6*
	2.3	2.3	2.3	2.3

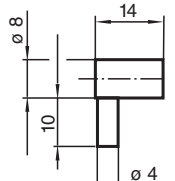
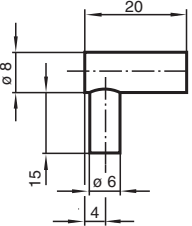
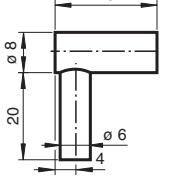
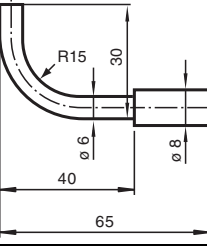
				
	Bar 10/4 mm	Bar 15 mm	Bar 20 mm	Radius 15 mm
K	K9	WC15	WC20	WR
y₁	1.1	1.1	1.1	1.1
	1.6	1.6	1.6	1.6
	-	1.9	1.9	1.9
	2.3 (thru-beam only)	2.3	2.3	2.3

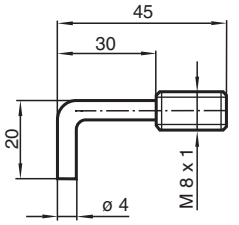
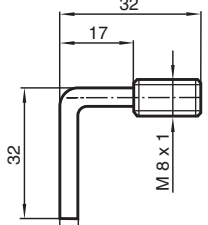
		
	Bar 20 mm / M8 x 1	Bar 32 mm / M8 x 1
K	K11	K12
y₁	1.1	1.1
	1.6	1.6
	2.3 (thru-beam only)	2.3 (thru-beam only)

Date of issue: 13.10.2011 DOCT-1524

Subject to modifications without notice

Pepperl+Fuchs Group
www.pepperl-fuchs.com

USA: +1 330 486 0001
fa-info@us.pepperl-fuchs.com

Germany: +49 621 776-4411
fa-info@pepperl-fuchs.com

Copyright Pepperl+Fuchs

Singapore: +65 6779 9091
fa-info@sg.pepperl-fuchs.com

Standard heads with flexible tip:

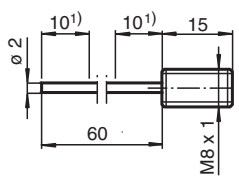
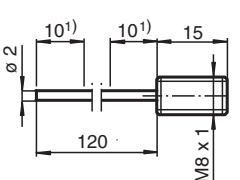
		
	60 mm tip	120 mm tip
K	K13	K14
y₁	0.8	0.8
	1.1 (thru-beam only)	1.1 (thru-beam only)

Standard heads with lateral light exit:

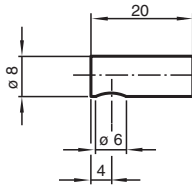
	
K	WC0
y₁	1.1
	1.6
	1.9
	2.3

This results, e.g. in the following complete model number:
e.g.:

LCE 18 - 1.1 - 1.0 - K3

If you fail to find what you are looking for in our comprehensive standard product range, you can ask one of our experts!

Additional accessories such as focussing lenses for increasing the detection range and sensing ranges are available on the Internet.

Order form for your fiber optics selection:

L x₁ x₂ 18 - y₁ - z₁ - k

Core material	Covering material x₁	Principle of operation x₂	Adapter	Diameter y₁	Length of fiber optic z₁	Fiber optic head k	Quantity
L			18				
L			18				
L			18				
L			18				
L			18				
L			18				
L			18				