

MANUAL

VISION SENSOR

VOS302 / 312



CE



With regard to the supply of products, the current issue of the following document is applicable: The General Terms of Delivery for Products and Services of the Electrical Industry, published by the Central Association of the Electrical Industry (Zentralverband Elektrotechnik und Elektroindustrie (ZVEI) e.V.) in its most recent version as well as the supplementary clause: "Expanded reservation of proprietorship"

1	Introduction	7
2	Declaration of conformity.....	8
3	Safety	9
3.1	Symbols relevant to safety	9
3.2	Intended use	9
3.3	General safety instructions	9
4	Product description	10
4.1	Use and application	10
4.2	Displays and controls	11
4.3	Interfaces and connections.....	11
4.3.1	Digital inputs/outputs	13
4.3.2	Serial RS 422 interface	14
4.4	Network interface	14
4.5	Delivery package	14
4.6	Accessories	15
4.6.1	Connecting additional illumination VOL300.....	15
5	Installation	16
5.1	Preparation.....	16
5.2	Mounting	16
5.3	Network configuration	17
5.3.1	Assigning an IP address to a network connection using Windows XP.....	17
5.4	Connection.....	19
5.5	Storage and transport.....	19
6	Commissioning	20

6.1	Function	20
6.1.1	Operating mode	20
6.1.2	Methods	20
6.1.3	Position correction	21
6.1.4	Functional process.....	21
6.2	Image capture	23
6.3	Position correction	24
6.4	Checks	24
6.4.1	Method.....	25
6.4.2	Working area	25
6.4.3	Teaching in patterns	26
6.4.4	Evaluating the checks	27
6.4.5	Sensor configuration	27
7	PC software	28
7.1	Minimum system requirements for VOS3-Config	28
7.2	Installation	28
7.3	User levels	28
7.3.1	User level selection.....	29
7.3.2	Administrator level	30
7.3.3	User level.....	31
7.4	Notes on operation	32
7.4.1	Numerical input fields.....	32
7.4.2	Tool tips	32
7.4.3	Program options.....	33
7.4.4	Operating modes	34
7.5	Buttons	34
7.5.1	Connection options	35
7.6	Image display	39
7.7	Display results	40
7.8	Status bar	40

7.9	General settings	41
7.9.1	Image capture	41
7.9.2	Recorder page.....	42
7.9.3	Common.....	43
7.10	Test functions.....	44
7.10.1	Single test.....	44
7.10.2	Complete test runs	45
7.11	Job manager	47
7.12	Position detection and correction	52
7.12.1	Pattern	53
7.12.2	Blob	56
7.12.3	Edge detection	57
7.12.4	Contour.....	59
7.12.5	Notes on using position correction	64
7.13	Attribute evaluations ("Checks")	66
7.13.1	Pattern	66
7.13.2	Contrast.....	69
7.13.3	Grayscale value.....	69
7.13.4	Contour.....	71
7.13.5	Gradient.....	76
7.13.6	Position check	77
7.14	Password manager.....	80
8	Telegrams for communication via serial and network interfaces	81
8.1	Telegrams for sensor	82
8.2	Telegrams from the sensor	84
9	Maintenance and repair	95
9.1	Maintenance.....	95
9.2	Repair	95



- 10 Troubleshooting 96**
- 10.1 What to do in the event of an error 96

- 11 Appendix 97**
- 11.1 Dimensions 97
- 11.1.1 Sensor VOS302/VOS312 97
- 11.1.2 OMH-VOS300-K01 97
- 11.1.3 OMH-VOS300-01 97

1 Introduction

Congratulations

You have chosen a device manufactured by Pepperl+Fuchs. Pepperl+Fuchs develops, produces and distributes electronic sensors and interface modules for the market of automation technology on a worldwide scale.

Before you install this device and put it into operation, please read the operating instructions thoroughly. The instructions and notes contained in this operating manual will guide you step-by-step through the installation and commissioning procedures to ensure trouble-free use of this product. By doing so, you:

- guarantee safe operation of the device
- can utilize the entire range of device functions
- avoid faulty operation and the associated errors
- reduce costs from downtimes and incidental repairs
- increase the effectiveness and operating efficiency of your plant.

Store this operating manual somewhere safe in order to have it available for future work on the device.

Directly after opening the packaging, please ensure that the device is intact and that the package is complete.

Contact

If you have any questions about the device, its functions, or accessories, please contact us at:

Pepperl+Fuchs GmbH
Lilienthalstraße 200
68307 Mannheim
Telephone: +49 621 776-4411
Fax: +49 621 776-274411
E-Mail: fa-info@pepperl-fuchs.com

2 Declaration of conformity

This product was developed and manufactured under observance of the applicable European standards and guidelines.



Note!

A Declaration of Conformity can be requested from the manufacturer.

The product manufacturer, Pepperl+Fuchs GmbH, D-68307 Mannheim, has a certified quality assurance system that conforms to ISO 9001.



3 Safety

3.1 Symbols relevant to safety



Danger!

This symbol indicates a warning about a possible danger.

In the event the warning is ignored, the consequences may range from personal injury to death.



Warning!

This symbol indicates a warning about a possible fault or danger.

In the event the warning is ignored, the consequences may course personal injury or heaviest property damage.



Caution!

This symbol warns of a possible fault.

Failure to observe the instructions given in this warning may result in the devices and any connected facilities or systems develop a fault or fail completely.

3.2 Intended use

Vision Sensors VOS302 and VOS312

A maximum of 16 configurations (so-called "Jobs") can be stored on 300 series Vision Sensors. Each job in the VOS302 consists of a check with position correction, whereas on the VOS312 it consists of 6 checks with position correction.

Of this maximum number of 16 stored jobs, only one can be active at any given time. This job is then executed by the sensor in Automatic mode or can be parameterized in Setup mode.

You can only modify, load or save characteristic checks using VOS3-Config parameterization software installed on a PC.

3.3 General safety instructions

Only instructed specialist staff may operate the device in accordance with the operating manual.

Independent interventions and separate modifications are dangerous and will void the warranty and exclude the manufacturer from any liability. If serious faults occur, stop using the device. Secure the device against inadvertent operation. In the event of repairs, send the device to Pepperl+Fuchs.

The vision sensors are not safety components as specified in EU machinery directives and using them in applications where personal safety depends on device functions is not permitted.

The operating company bears responsibility for observing locally applicable safety regulations.

Store the not used device in the original packaging. This offers the device optimal protection against impact and moisture.



Note!

Electronic waste is hazardous waste. Observe local disposal regulations.

4 Product description

4.1 Use and application

Vision sensors VOS3*

Vision Sensor VOS3* are optical sensors based on image processing technology. Due to their flexible configuration options and evaluation methods, the devices can be used for a wide variety of automation tasks, e.g., part detection and checking, position detection, etc.

All the components required for operating an image processing system, e.g., image capture chip, projection lens, illumination and evaluation computer with interfaces are fitted inside the compact housing of the device. The sensors are genuine stand-alone devices; a PC is only required for setup and maintenance.

A maximum of 16 configurations (so-called "Jobs") can be stored on VOS3* Vision Sensors. Each job in the VOS302 consists of a check with position correction, whereas on the VOS312 it consists of 6 checks with position correction. You can only modify, load or save characteristic checks using VOS3-Config parameterization software installed on a PC.

Of this maximum number of 16 stored jobs, only one can be active at any given time. This job is then executed by the sensor in Automatic mode or can be parameterized in Setup mode.

In addition, either the serial port (RS 422) or the Ethernet port can be used for data output.



4.2 Displays and controls

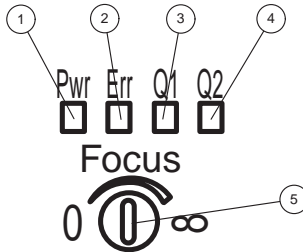

Figure 4.1: **Rear of VOS300 sensor**

- 1 Pwr. (green): Operating voltage
- 2 Err. (red): Fault
- 3 Q1 (yellow): Result 1 (checks OK)
- 4 Q2 (yellow): Result 2 (position OK)
- 5 Focus adjustment screw

4.3 Interfaces and connections

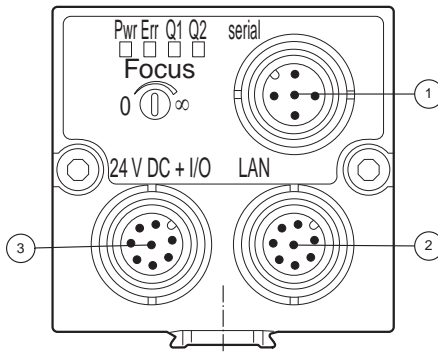

Figure 4.2: **VOS300 output and input signals**

1. Serial interface (5-pin M12 connector)
2. Network (8-pin M12 connector)
3. Power supply, inputs and outputs (8-pin M12 connector)

Power supply

There is an 8-pin M12 plug on the rear of the sensor housing for connecting the power supply and the inputs and outputs. The signals RESULT and POSITION are used to transfer the test results to a control or control element such as a solenoid valve.

The following diagram shows the pin assignment:

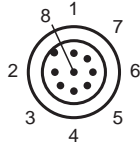

Figure 4.3: Connection layout for supply voltage and inputs and outputs

- 1 Trigger input (IN1)
- 2 24 V supply to device
- 3 Output RESULT (OUT3)
- 4 Output READY (OUT2)
- 5 Input 2 (IN2)
- 6 Output EXT_ILL (OUT1)
- 7 Device ground (GND)
- 8 Output POSITION (OUT4)

Network

There is an 8-pin M12 connector on the rear of the sensor housing for connecting to the network. The following diagram shows the pin assignment:

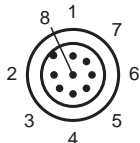

Figure 4.4: Network connection layout

- 4 Transmit Data (-)
- 5 Receive Data (+)
- 6 Transmit Data (+)
- 8 Receive Data (-)

Serial interface

There is a 5-pin M12 connector on the rear of the sensor housing for connecting an RS 422 interface. The following diagram shows the pin assignment:

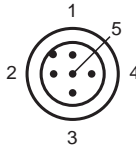

Figure 4.5: Serial interface connection layout

- 1 Receive Data (+)
- 2 Receive Data (-)
- 3 Transmit Data (+)
- 4 Transmit Data (-)
- 5 GND

The factory default settings are configured for triggered sensor operation, i.e., the TRIGGER input signal and the READY output signal are used to synchronize the sensor and the transmission of results with the process under test and the control.

In the simplest case, only the RESULT output signal is used to transmit the test result to a control. In this case, the sensor has to be configured to operate autonomously so that it carries out continuous tests automatically.

4.3.1 Digital inputs/outputs

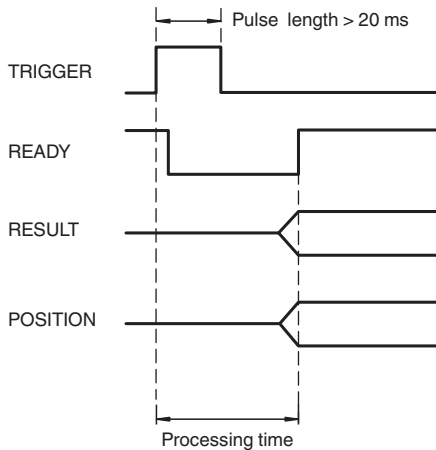

Figure 4.6: Impulse diagram

4.3.2 Serial RS 422 interface

The transfer parameters of the serial RS 422 interface (connector J2) are:

Data bits:	8
Stop bits:	1
Parity:	None
Baud rate:	9600 to 115200

The baud rate is preset using VOS3-Config:

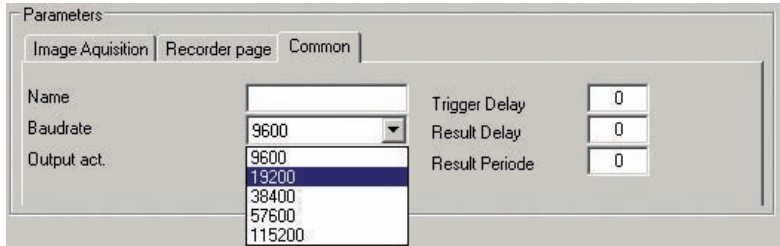

Figure 4.7: Interface tab

4.4 Network interface

The TCP/IP network interfaces output the result protocol via port 2005 after every check. The sensor commands are sent via the same port. Refer to the following sections for more information: see chapter 5.3 and see chapter 8.

4.5 Delivery package

The delivery package contains:

- Vision sensor
- CD with PC configuration program VOS3-Config and operating instructions
- Dovetail clip
- Allen key, screwdriver

4.6 Accessories

Item	Designation	Note
1	V19-G-3M-PUR ABG	Connecting cable for 24 V and inputs/outputs 3 m, M12 socket, 8-pin, shielded, other side open
2	V19-G-3M-PUR ABG-V45X-G	Ethernet cross-over cable, for parameter assignment with PC; 3 m, M12 socket, 8-pin/RJ 45, shielded
3	V19-G-3M-PUR ABG-V45-G	Ethernet cable, for direct connection to a network; 3 m, M12 socket, 8-pin/RJ 45, shielded
4	V15-G-5M-PUR	Cable for RS 422 serial interface; 5 m, M12 socket, 5-pin
5	V19-G-0.5M-PUR ABG-V19-G	Illumination cable, 0.5 m, 2x M12 socket, 8-pin
6	OMH-VOS300-K01	Dovetail terminal block
7	OMH-VOS300-01	Mounting bracket
8	VOL300-FL45-WH	Rectangular external illumination, white
9	VOL300-FL45-RT	Rectangular external illumination, red

4.6.1 Connecting additional illumination VOL300

Optional additional illumination units for the Vision Sensors VOS302/VOS312 and connection cables (V19-G-0.5M-PUR ABG-V19-G) are available for these illuminations. They are connected as follows:

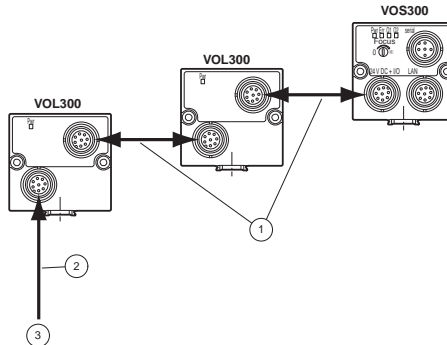

- 1 2x V19-G-0.5M-PUR ABG-V19-G
- 2 V19-G-3M-PUR ABG
- 3 Power supply + I/O signals

The illumination is looped into the power supply and I/O cable using the cable V19-G-0.5M-PUR ABG-V19-G. The OUT connector on the illumination unit is connected to the 24VDC+IO connector on the sensor via the cable V19-G-0.5M-PUR ABG-V19-G. Power is supplied and the input/output signals are connected to the IN connector of the illumination via the cable V19-G-3M-PUR ABG.

A maximum of 4 red and 2 white VOL300 additional illuminations can be connected using this method.

5 Installation

5.1 Preparation



Unpacking the unit

1. Check that all package contents are present and undamaged.
If anything is damaged, inform the shipper and contact the supplier.
2. Check that all items are present and correct based on your order and the shipping documents.
If you have any questions, please contact Pepperl+Fuchs.
3. Keep the original packing material in case you need to store or ship the unit at a later time.

5.2 Mounting

The vision sensor must be attached using the dovetail clip in such a way that the field of vision is in the desired position. The size of the field of vision depends on the operating distance:

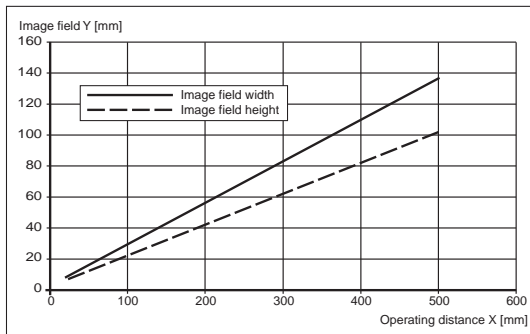

Figure 5.1: Installation instruction - operating distance

An additional illumination may be required for operating distances greater than 100 mm.

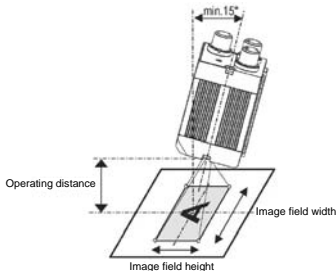

Figure 5.2: Installation instruction - Angle

The final mechanical alignment can only take place after the electrical connections have been made because the captured images can then be displayed on the PC using the operating software.

5.3 Network configuration

Communication with the sensor is carried out via a free Ethernet interface on the PC. It is usually an integrated LAN interface.

This interface must be assigned an address (IP address) so that it can establish a connection with the sensor.

The various stations in a TCP/IP network are identified via IP addresses. Each IP address must only be used once within a subnet. IP addresses are made up of 4 blocks, each with a three-digit number between 0 and 255 (8 bit), e.g., 192.168.0.65.

Example: IP address 192.168.100.100 with subnet mask 255.255.255.0

A device with these settings can establish direct communication with any IP address between 192.168.100.0 and 192.168.100.255. (The first three blocks must match.)

In TCP/IP networks, fixed IP addresses can be set on the device or they can be assigned dynamically by a DHCP server.

VOS302/VOS312 Vision Sensors do not support DHCP, i.e., only fixed IP addresses can be used.

The Ethernet interface used on the PC to communicate with the vision sensor must be configured in line with the vision sensor settings. The factory defaults for the VOS302/312 are IP number 192.168.100.100 and subnet mask 255.255.255.0. Therefore, an IP number between 192.168.100.0 and 192.168.100.255 must be set on the PC, **however, not 192.168.100.100**. To establish communication with the sensor, the port must also be defined independently of the IP. The communication port on the VOS3* is **2005**.

Example:	IP 192.168.100.100	Subnet mask
Sensor setting:	IP 192.168.100.90	255.255.255.0
LAN interface on the PC:		Subnet mask
		255.255.255.0

5.3.1 Assigning an IP address to a network connection using Windows XP

To assign an IP address to a network connection using Windows XP, proceed as follows.



1. First select **Network connections**:

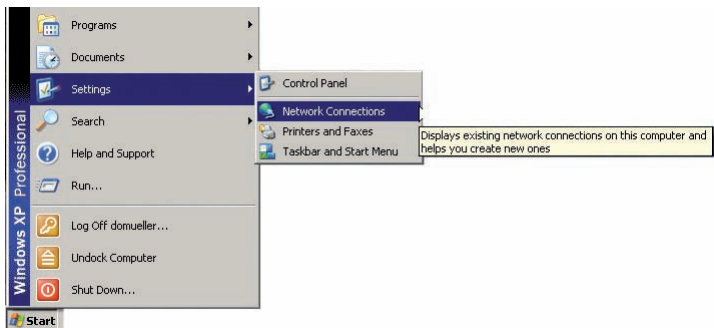

2. Open the required connection by double clicking it.

The Properties dialog box for the relevant connection will open.

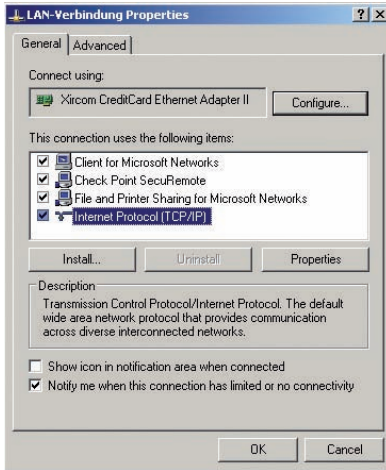

3. Select the **Internet Protocol (TCP/IP)** element from the Properties dialog box by double clicking it.

The TCP/IP properties dialog box will open.

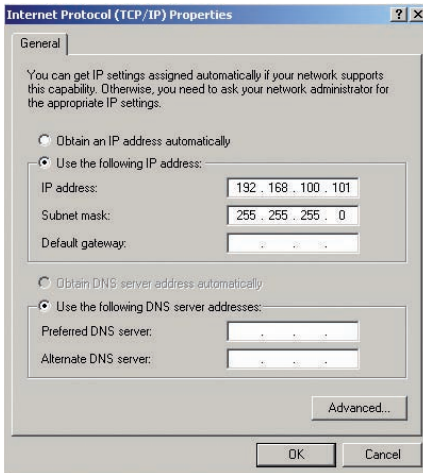

4. In the TCP/IP properties dialog box, select **Use the following IP address**.
5. Enter an IP address that only differs from the sensor IP address in the very last segment.
6. Enter 255.255.255.0 as the subnet mask.
7. Then confirm your entries on the TCP/IP properties page and the LAN connection properties page by clicking **OK** and **Close**.

This completes the network configuration and the sensor can be used.

5.4 Connection



Connecting the power supply

To supply power to the sensor, proceed as follows:

1. Plug the 8-pin M12 socket into the connector provided for this purpose on the back of the housing. See view Figure 4.5 on page 13 for the connector assignment.
2. Screw the cap nut as far as it will go over the connector.

This ensures that the power cable cannot be inadvertently pulled out.



Note!

Record the network configuration

The sensor communicates with the connected machine control system using the TCP/IP protocol. To ensure communication works correctly, you must note all the changes you make to the network configuration.



Note!

Network cabling

Use a crossover network cable to connect the sensor directly to a PC. If the sensor is being operated within a network, use a twisted-pair network cable to connect it to the network.



Establishing a network connection

To establish a network connection, proceed as follows.

1. If you are using a network cable with an RJ45 network plug at one end and an 8-pin M12 socket at the other, insert the 8-pin M12 socket in the connector on the back of the sensor.
2. When delivered, the sensor has a fixed IP address (192.168.100.100). To facilitate communication within the network, you must configure your network. The configuration data can be found in the network configuration overview.



Connecting the serial interface

To connect the serial interface to a computer, proceed as follows:

Plug the 5-pin M12 socket into the connector provided for this purpose on the back of the housing. See view Figure 4.5 on page 13 for the connector assignment.



Note!

The protective caps included in the delivery must be plugged into the unused M12 connectors (serial and LAN) before the sensor is operated. Ignoring this instruction may result in malfunctions.

5.5 Storage and transport

For storage and transport purposes, package the unit using shockproof packaging material and protect it against moisture. The best method of protection is to package the unit using the original packaging. Furthermore, ensure that the ambient conditions are within allowable range.

6 Commissioning

6.1 Function

A vision sensor consists of a camera with illumination and an evaluation computer. Attributes are calculated and evaluated ("checks") within the selected ranges of the camera field of view. Both the size and the position of the evaluation range within the field of view can be selected as required.

The VOS302 offers one check and the VOS312 a maximum of 6 checks.

6.1.1 Operating mode

The sensor has two operating modes: **Automatic** and **Setup**.

Automatic: The device is completely automatic. The network interface can be used to transmit test results, but a connection to a PC is not essential.

Setup: **Setup** operating mode is used to parameterize the sensor using the VOS3-Config software. A connection to a PC is essential, however.

Automatic mode is always active when the sensor switches on. When the VOS3-Config software is started and a connection with the sensor is established, the sensor operating mode switches to **Setup**. The parameterization data is saved permanently in the sensor, i.e., it remains intact even when the power supply is switched off. The sensor returns to Automatic mode when VOS3-Config is closed.

6.1.2 Methods

5 different methods are available for characteristic checks:

- **Gray value:** Checks whether the brightness of the image ("gray value") in the working range matches the specified value.
Used for checking presence on homogeneous background, for example.
- **Gradient:** Checks whether the specified number of light/dark or dark/light transitions is found within the working range.
Use to differentiate differently structured labels, for example.
- **Contrast:** Checks whether the contrast in the working range matches the specified value.
Used for checking imprints on homogeneous background (expiration date), for example.
- **Pattern:** Checks whether there is a taught pattern within the working range. The position of the pattern within the image is also checked.
Used to identify/verify imprints or labels, for example.
- **Contour:** Checks whether there is a taught contour within the working range. The position of the contour within the image is also checked.
Used for position detection in feed devices, for example.

6.1.3 Position correction

Mechanical tolerances on the test component feed system, inaccurate trigger signals or other interfering influences may mean that the evaluated object is not always located in exactly same position that the sensor recorded in the image.

This may result in large inaccuracies during the identification of attributes, especially with the gray value, contrast and gradient methods.

The position can be corrected in the image before the actual characteristic check is performed to compensate for these influences. This merely determines the position of the object in the image in relation to the position during setup. An attribute evaluation is not yet carried out, however.

Several procedures are available for position correction:

- **Blob:** The center of gravity of the biggest dark or light object is determined within a search area.
- **Edge detection:** A search for the first light/dark or dark/light edge is run in each of two search areas (horizontal and vertical) and its position defined. The search directions (left to right / right to left or top to bottom / bottom to top) can be selected.
- **Pattern:** The position of a taught pattern is determined.
- **Contour:** The position of a taught contour is determined.

When the position is corrected, the working areas move and the checks start at the positions taught into the system. It is possible to define movements using the methods **blob**, **edge detection**, **pattern** and **contour**.

6.1.4 Functional process

During automatic operation, the following steps are executed in sequence:

- Image capture
- Position correction (optional)
- Check 1
- Check 2 to check 6 (only for VOS312)
- Result generation

Image capture

The first step is the image capture, which can be performed independently or synchronized via the TRIGGER input ("triggered").

Independent means that the sensor keeps capturing and processing images automatically.

With a triggered image capture, each positive impulse at the TRIGGER input triggers and processes an image.

Checks

After the position is determined, up to 6 characteristic checks are carried out; the gray value, contrast, gradient, pattern and contour methods are available for each check.

The checks are carried out separately with each check providing 2 binary results:

- **Check OK** or **Check not OK**: The characteristic allocated to the check is either fulfilled or not fulfilled.
- **Position OK** or **Position not OK**: With the "pattern comparison" and "contour comparison" methods, it is possible to check whether the position of the pattern found is within a predefined target area.

Result generation

The overall (binary) results for "Check" and "Position" are formed using AND combinations and the binary results from the individual checks. The outputs RESULT (Checks) and POSITION (Positions) are set to "High" (=good) or "Low" (=bad) depending on these results:

All checks OK:	Output RESULT = High
One (or more) checks not OK:	Output RESULT = Low
All position checks OK:	Output POSITION = High
One (or more) position checks not OK:	Output POSITION = Low

The output READY is set by the trigger impulse **Low**. As soon as the results are valid, READY is set to **High** (see chapter 4.3.1).

The exact functionality and parameterization of the individual functional blocks is explained in detail in see chapter 7.

6.2 Image capture



Step 1: Parameterizing image capture

The first step in setting up the Vision Sensor is the parameterization of the image capture. If the factory defaults have to be adjusted for the selected application, only the trigger mode and the shutter time are usually affected.

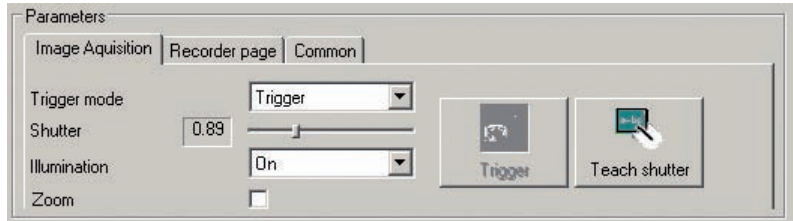

The trigger mode is preset to "Triggered," i.e., the image capture of the sensor is triggered by an external trigger signal. The "Trigger" button in triggered image capture is used to trigger an image manually for test purposes.

Alternatively, the sensor can also work in continuous operation and automatically keep capturing images.

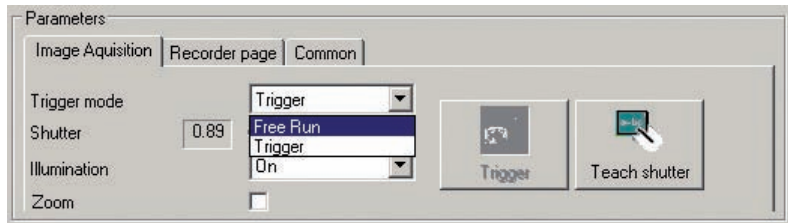

1. The shutter time (exposure time) sets the image brightness. The image must be neither overexposed (too bright) nor underexposed (too dark).
2. Pressing "Teach shutter" teaches the shutter time automatically.
3. The setting can be selected manually using the "Shutter" slider. A number indicating the preset time is displayed next to the slider.



The other setup options for image capture are explained in see chapter 7.9.1.

6.3 Position correction

Step 2: Selecting and setting the position correction process

In the simplest case, no position correction is used, i.e., the subsequent checks work directly on the image. This is also the default setting.

For the gray value, gradient and contour check methods it is, however, often necessary to correct the working areas in the image. Position correction is provided for such cases.

The position correction function is used to locate the object to be inspected (or parts thereof) in the image window. The subsequent checks build on the position correction, i.e., their working areas are moved according to the calculated position.

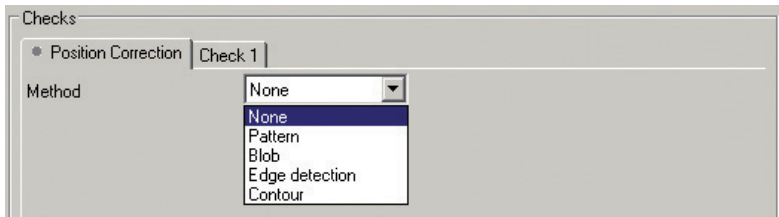

Figure 6.1: Position correction tab

The different methods and their parameterization are explained in detail in view Figure 6.1 on page 24.

6.4 Checks



Step 3: Selecting and setting a minimum of one check

As the third step of commissioning, one or more characteristic checks are positioned and adjusted in the image. The checks are the actual inspection functions of the sensor. One check can be activated on the VOS302 and a max. of 6 checks can act on the sensor image on the VOS312.

In addition to the "Position correction" tab, there is a tab for each check:

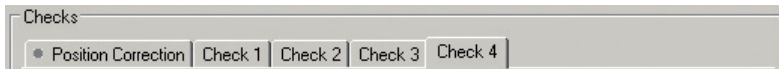

1. Press the "Add check" button to add characteristic checks on the VOS312.
2. Press the "Del. check" button to remove characteristic checks on the VOS312.



6.4.1 Method

For each check, there are 5 different evaluation methods available for selection:

- Pattern
- Contrast
- Gray value
- Contour
- Gradient

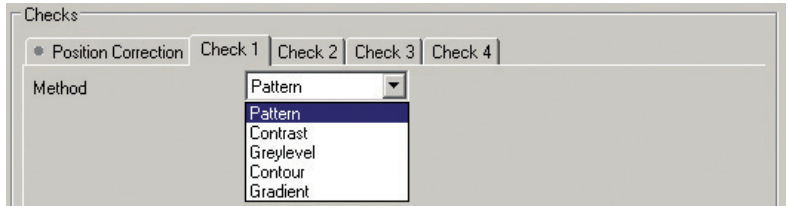

The "Pattern" method is the default setting for all checks, because it is easiest to configure. Representative for the setup of the methods, this chapter briefly describes how to teach in a pattern.

The individual methods and their different setup options are described in detail in chapter 7.13.

6.4.2 Working area

At the start of the setup procedure, a working area is defined for each method. The working areas are shown in the image display at the top right of the screen as yellow rectangles. The check associated with the working area is shown in the top left corner of the yellow rectangle. If the tab of the corresponding sensor is selected, the working area is marked and can be moved or resized in the image.

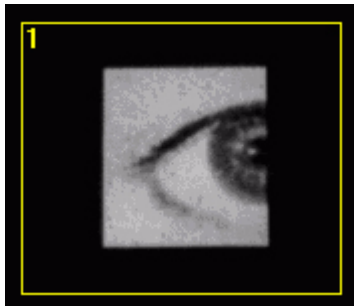

6.4.3 Teaching in patterns



Teaching in a pattern

With the **pattern** method, a red rectangle can be seen in the image display in addition to the yellow working area rectangle. The black dotted marking can be moved from the yellow working area rectangle to the red pattern rectangle by double-clicking the red rectangle. The red rectangle can then be moved and varied in size. The red rectangle must always be within the yellow working area.

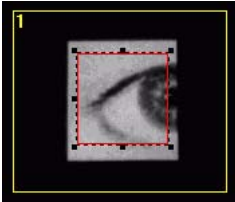

1. Place the red rectangle around the pattern you wish to teach in.
2. Press the **Teach** button.



The taught pattern then appears on the tab of the check:

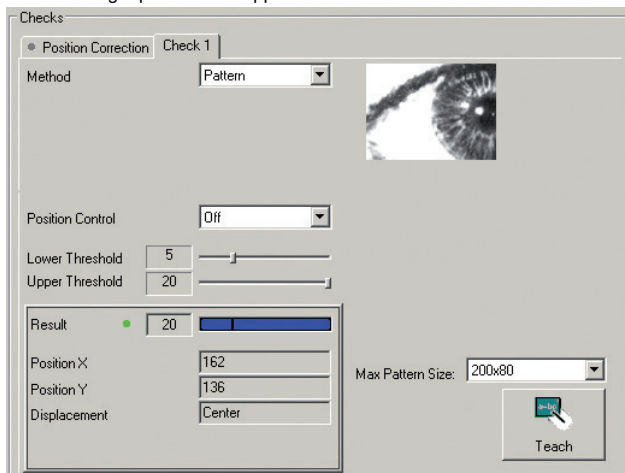

3. Pattern detections can be carried out using the **Single test** button. The degree of match is displayed under **Result** on the check tab above the **Single test** button.



6.4.4 Evaluating the checks

Every evaluation method has a result value. For this value, a good range is set using a lower and upper threshold (gray value, gradient, contrast, pattern methods) or only a single threshold value (contour method).

As long as the result value is within the good range, the test result of the check is "good," otherwise it is "bad."

After pressing the "Single test" button, the check is executed with the set values and the result displayed as a bar graph below the threshold value sliders.



6.4.5 Sensor configuration

After setting the threshold values, the setup of the check is complete. The function of the vision sensors can be monitored after pressing the **Run job** button. The numbers of the checks carried out and the good and bad results of the individual checks can be viewed in the result display area.

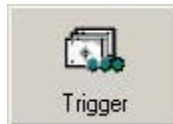

Caution!

With triggered image capture, the sensor still only captures images after a trigger signal, even in test mode. If necessary, trigger signals can be simulated by pressing the "Trigger" button.

The test operation continues until the **Stop** button is pressed.

7 PC software

This chapter describes in detail the PC program VOS3-Config that is used to parameterize Vision Sensors VOS302/VOS312 as well as all existing value settings.

7.1 Minimum system requirements for VOS3-Config

Processor:	Pentium 4 or equivalent processor
Pulse frequency:	1 GHz
Memory:	256 MB RAM
Free hard disk capacity:	20 MB
Screen resolution:	1024 x 768 pixels
Operating system:	Windows2000, WindowsXP or Windows Vista

7.2 Installation

The sensor is accompanied by a CD that either starts automatically when inserted in the CD drive or is started by running the "start.exe" program on the CD. **Software installation** can be selected once the language is specified.

Alternatively, VOS3-Config can be installed directly by opening the setup file in the **Software** directory on the VOS300 CD.

A directory called VOS3-Config is created during the installation, into which all required files are then copied. A subdirectory containing sample images called "Simulation" is also created. A P+F icon for starting the VOS3-Config program is added to the desktop and the start menu.



Note!

The installation does not require administrator rights.

7.3 User levels

VOS3-Config can be opened in 2 different user levels:

- User level **User**
- Administrator level **Admin**



Note!

The **Admin** level is password-protected. During installation this password is "PF". To modify the password, open the password manager passm.exe (see chapter 7.14).

7.3.1 User level selection

When VOS3-Config starts, the user level must be selected first of all:

- The **User** level can be accessed without entering a password, whereas the **Admin** level can only be accessed by correctly entering the password created in the password manager.
- In the **User** level, the image capture from the sensor can be checked and files containing sensor settings can be loaded to the sensor and saved to files. However, sensor parameters cannot be modified. This is reserved for the **Admin** level.



Note!

When the sensor is switched on for the first time, it must initially be configured in the **Admin** administrator level.



7.3.2 Administrator level

The administrator level screen appears as follows:

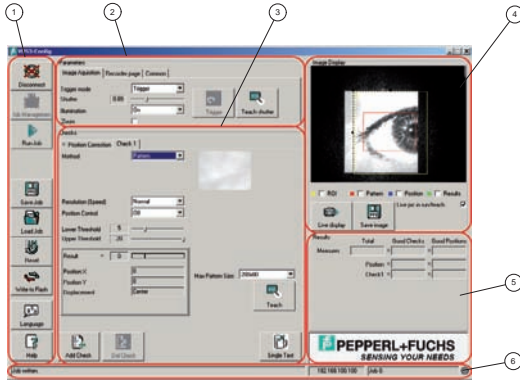

Figure 7.1: Layout and elements on the **Admin** user level

- 1 Buttons (see chapter 7.5)
- 2 General settings (see chapter 7.9)
- 3 Configuration of position correction and checks (see chapter 7.12 and see chapter 7.13)
- 4 Image display (see chapter 7.6)
- 5 Result display (see chapter 7.7)
- 6 Status bar (see chapter 7.8)

7.3.3 User level

The display and controls in the user level are available to a limited extent:

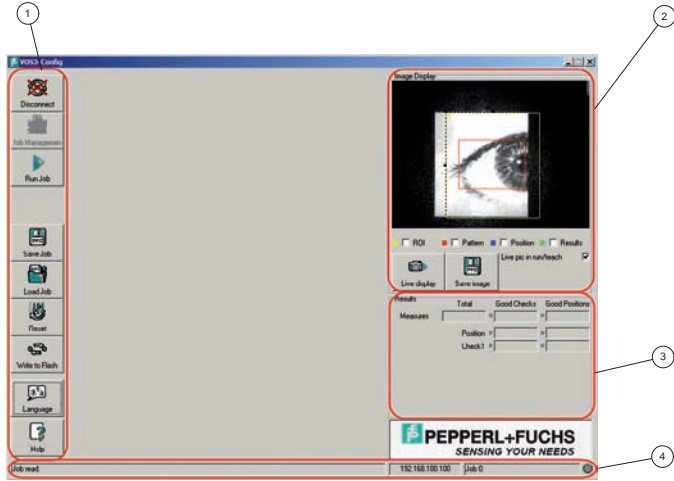

Figure 7.2: Layout and elements on the **User** user level

- 1 Buttons (see chapter 7.5)
- 2 Image display (see chapter 7.6)
- 3 Result display (see chapter 7.7)
- 4 Status bar (see chapter 7.8)



7.4 Notes on operation

7.4.1 Numerical input fields

A number indicating the slider setting is displayed next to each slider. A numerical input mask for entering slider value settings can be opened by clicking in these fields:

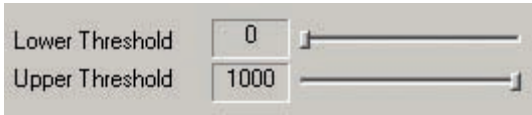

Figure 7.3: Numerical display next to the sliders

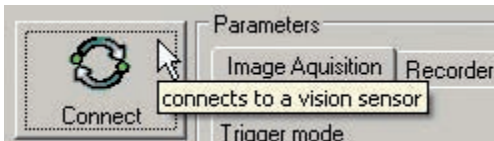

Figure 7.4: Numerical display next to the sliders and input field for numerical values

In the German version, a comma (",") is always used as a decimal delimiter.

7.4.2 Tool tips

A brief explanatory text ("Tool tip") appears next to all control elements when the mouse pointer is moved across the corresponding element:



7.4.3 Program options

When clicking on the P+F Logo in the upper left corner of the VOS3-Config window, the following menu appears displaying various options relating to the execution of VOS3-Config:

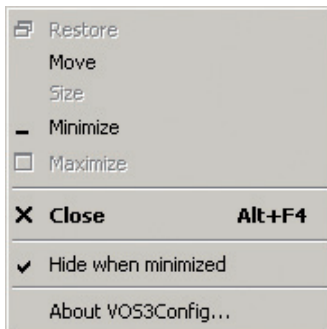
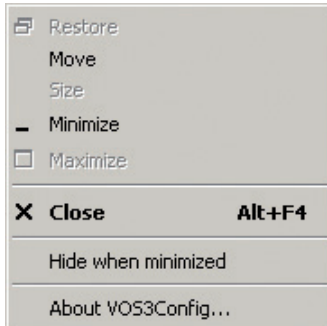

Move, **Minimize** and **Close** are standard Windows options.

When the option "Hide when minimized" (shown by a checkmark) is selected, VOS3-Config is only shown in the tray when the program window is minimized, not in the task bar.

After clicking **About VOS3-Config**, the version of VOS3-Config.exe is displayed above the copyright notice:



7.4.4 Operating modes

VOS3-Config can be operated in 2 different ways: with a VOS3xx sensor connected or in simulation mode.

With a VOS3xx sensor connected, images are captured by the sensor and displayed on the screen. All settings are transferred to the sensor and stored there.

In simulation mode, the VOS3-Config program works with the image files stored on the PC. A sensor is not required. With **Start test**, the selected image files are loaded and processed automatically or consecutively when the "Trigger" button is pressed, depending on the preset trigger mode. In simulation mode, job files can be loaded and saved again. Job files created in this way can also be loaded to a real sensor.

7.5 Buttons

The buttons control the operating modes of the sensor and the PC user interface. After opening VOS3-Config only the **Connect** button is enabled initially and all other buttons can only be used if a sensor is connected. The first step after opening the program is to establish a connection by pressing **Connect**.



Connect / Disconnect: Establishing or severing the network connection with the sensor or loading image files for the simulation mode. The successful connection is indicated in the status bar ("Status: connected to 192.168.100.100").
The various connection options are explained in see chapter 7.5.1.



Job manager: Managing individual jobs.



Start / stop test: Starting or stopping the automatic test mode. In simulation mode, the images captured by the sensor are transferred to the PC and displayed there. The result area further displays how many good or bad tests were carried out.



Save job: Saves the current sensor setting in a file on the PC. The sensor data are saved in a *.pfc file.



Load job: Loads a setting saved in a *.pfc file on the PC to the sensor. The previous setting on the sensor is overwritten.



Reset:The connected sensor is reset to the factory default settings. A security prompt appears before this is carried out.
Caution: All settings on the sensor will be lost during a reset.



Write to Flash: The current setting is stored permanently in the sensor. When working with VOS3-Config, parameter changes are made exclusively in the RAM memory of the sensor and are only written to the permanent sensor memory when the connection between VOS3-Config and the sensor is severed or after pressing the **Write to Flash** button.



Language: Changes the user guidance from German to English. When the language is changed, VOS3-Config must be closed and restarted before the new setting can take effect.



Help: Displays this document as a help file.

7.5.1 Connection options

Because several sensors can be active within the network, the sensor (i.e. IP number) used to establish the connection must be selected first of all.

The Vision Sensors VOS302/VOS312 have both Flash-ROM and RAM memories.

When the VOS3-Config software is connected to a sensor, the sensor configuration is read from the permanent Flash-ROM memory and transferred. When working with VOS3-Config, parameter changes are made in the RAM memory of the sensor and only written to the permanent sensor memory after exiting VOS3-Config or after pressing the button "Write to Flash."

The content of the Flash-ROM memory remains stored even after the power supply is switched off, whereas the RAM memory is deleted when switched off.

Alternatively, it is possible to work without sensors and only with saved images (offline simulation).

After pressing "Connect," the following options are available:

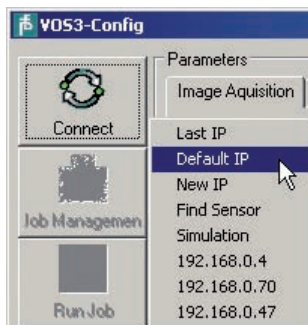

The last 4 IP numbers that were used appear in the last four lines, "**Last IP**" selects the IP used for the last active connection. The number of the "**Standard IP**" is 192.168.100.100. "**New IP**" is used to enter a new IP:

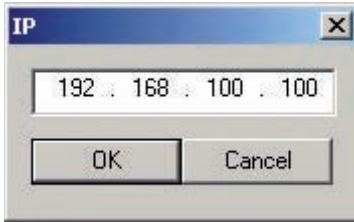

Caution!

Connections

Connections to sensors can only be established in the subnet area of the Ethernet connection used on the PC (see chapter 5.3).



Searching for sensors

If the IP of the connected sensor is unknown, the network can be searched for sensors. Proceed as follows:

1. Click the connection option "**Search for sensors**".

The "**Sensor search**" dialog box appears.

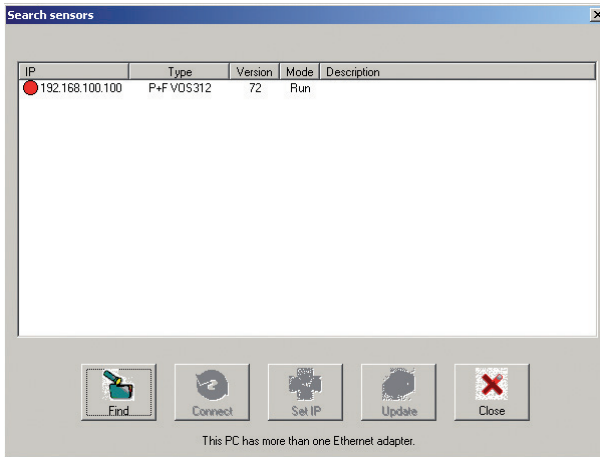

2. Click on "**Search**":

An IP area is searched and all located sensors as well as the sensor type, software version and current operating mode (normally "Automatic") are listed. Type "**P+F VOS302**" or "**P+F VOS312**" can be selected from this list.

3. Click "**Connect**":

A connection to the sensor is established. The sensor operating mode changes from "Automatic" to "**Setup**" after a security prompt is confirmed:

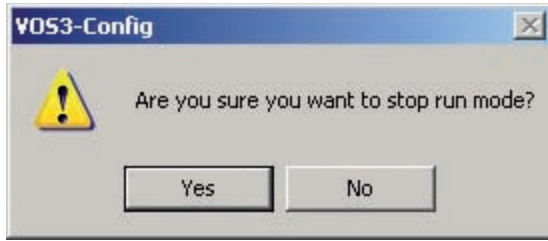

4. Click "**Set IP**".

The option "Modify IP" allows you to modify the IP number of a located sensor.

5. Click "**Update**".

Software installed on the sensor can be updated using the "Update" option. A valid update file is required.

Simulation

When the connection option "**Simulation**" is selected, a connection is not established to a sensor, instead images are loaded from the hard drive on the PC "Offline mode". To select the images, the simulation dialog is displayed containing a list of image files. At the start, the list is initially empty:

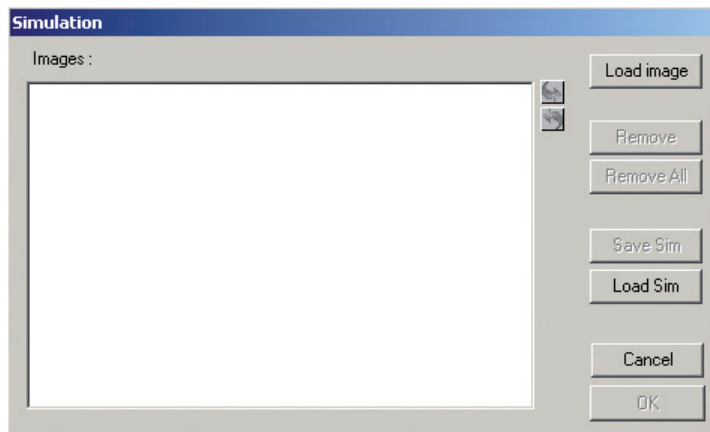

With **"Load image"**, a dialog opens for selecting image files from the PC hard drive. It is possible to select several files to run consecutively in the simulation.

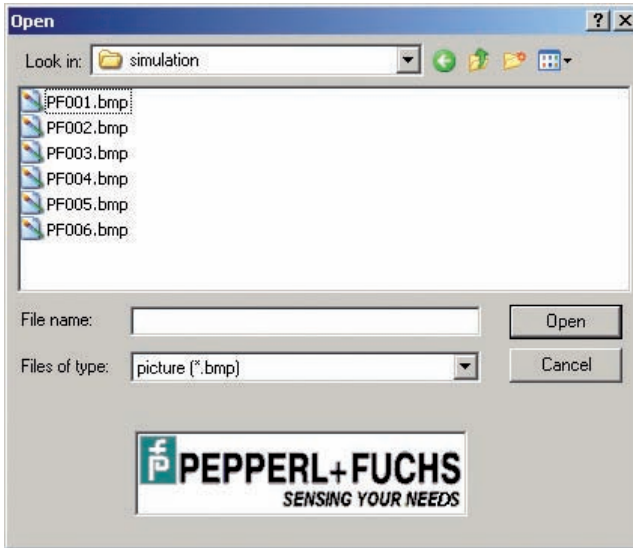

The selected files then appear in the simulation dialog list.

With **"Deselect"** and **"Deselect all"**, individual images or all images can be removed from the list.

With **Save sim**, this kind of simulation list can be saved in a *.sim file on the PC hard drive.

An existing simulation list can be loaded with **"Load sim"**.

"OK" closes the simulation dialog. The selected images are then processed as if they had just been captured by a sensor.

7.6 Image display

In the image display, images captured by the sensor are displayed at a reduced size. These may include images captured and edited in test mode or the (unedited) live image from the sensor.

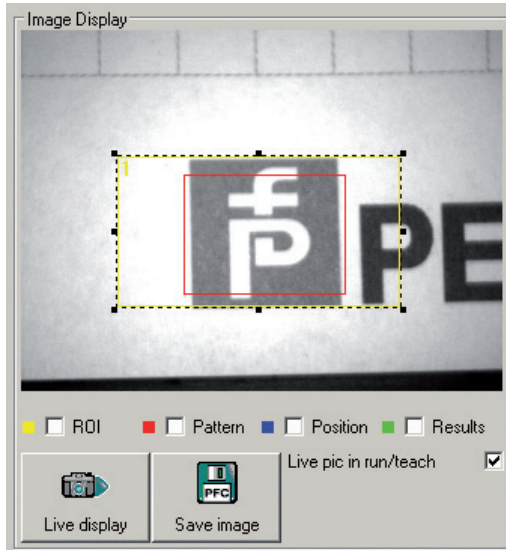

With **Live display**, an independent image capture is initiated. The sensor will then continue to capture images until "Live display" is stopped.

With **Save image**, the currently displayed image can be saved to a file on the PC hard drive. The areas shown in color can also be saved, if required.

The elements visible in the image window have the following meanings:

- **Yellow rectangle:** Working area: The number of the corresponding check is shown at the top left of the rectangle
- **Blue rectangle:** Permitted range for the position check of the characteristic check
- **Green rectangle:** Detected pattern for the "pattern" or "contour" methods
- **Red rectangle:** Template marking for teaching with the "pattern" or "contour" methods

Blue rectangles (position areas) are only shown for active position checks.

One of the yellow, red or blue rectangles can be selected by double clicking. A black dotted line then appears around the rectangle:

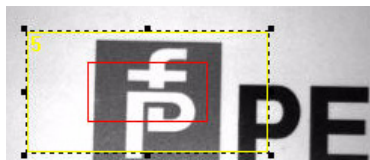

The highlighted rectangle can be moved and changed in size. The highlighting can be transferred to a different yellow, red or blue rectangle by double clicking.

If the **ROI**, **Pattern**, **Position** and **Results** checkboxes below the image are disabled (default setting), then only those elements of the check (working area, pattern area, etc.) whose tab is currently "on top" will be shown in the image window.

The elements of all characteristic checks are shown if the check boxes are enabled, in other words, the areas of the checks on the "hidden" tabs are also shown. The number of the check associated with this area is displayed in the top left corner of the working area (yellow).



Caution!

If **Live pic in run/teach** is enabled, the images captured by the sensor will appear in the image display throughout the duration of the test. Otherwise the image that last appeared on the display will remain during the test.

7.7 Display results

The number of good or bad tests in the simulation mode is displayed under **Test result**.

7.8 Status bar

The current status of the connected sensor, its IP number and the name allocated to the sensor (see chapter 7.9.3) are displayed in the status bar:



During test mode with continuous triggering, the average execution time is displayed on the left of the status bar:



7.9 General settings

There are three tabs in the area "General":

- Image capture: Setting the trigger mode and shutter time
- Recorder page: Setting the operating mode and retrieving images from the image memory integrated in the sensor
- Common: Setting the serial interface (RS 422) and the digital output and input signals

7.9.1 Image capture

The "Image acquisition" tab contains options for configuring the following parameters: Trigger mode, shutter time, illumination and zoom. All settings have default values that may need to be adjusted to the application.

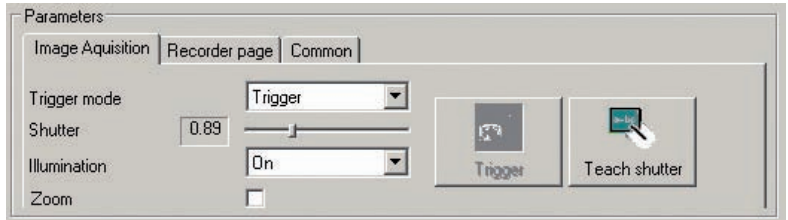

Trigger mode

Two operating modes are available to trigger the image capture. The default setting is **Triggered**, which is appropriate for most applications. In this case, the image capture of the sensor is triggered by an external trigger signal. A trigger impulse can be triggered for test purposes by pressing the **Trigger** button.

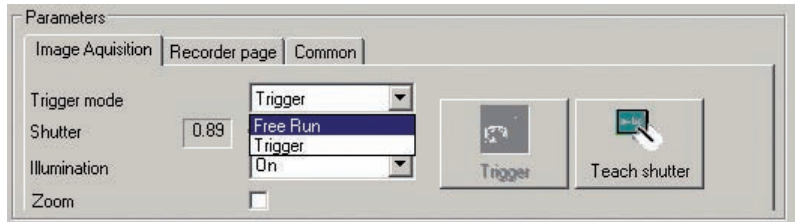

In independent operation, the sensor automatically captures and evaluates images.

Shutter time



A suitable shutter time must be set. The image must be neither overexposed (too bright) nor underexposed (too dark). This can be done automatically using **Teach shutter**.

The setting can be selected manually using the **Shutter** slider. A number indicating the preset time is displayed next to the slider.



A shutter time [in ms] can also be entered directly by clicking on the displayed number. A window for entering the shutter time then appears. In the German version, a comma (",") is always used as a decimal delimiter.



Illumination

External additional illuminations are available for Vision Sensors VOS302/VOS312 (see chapter 4.6.1 and see chapter 4.6). If you intend to work exclusively with external illumination, the LED illumination integrated in the sensor can be switched off with this selection. (Illumination is switched on by default).

Zoom

Enabling **Zoom** activates a 4-stage software zoom function, i.e., a section in the center of the image is displayed and processed magnified.

7.9.2

Recorder page

A maximum of 100 images from test procedures can be stored on the sensor during operation using the image memory function. The image memory is structured like a continuous ring buffer i.e., once 100 images have been stored, the next stored image will overwrite the first one. The last captured image always has the highest number.

In memory mode, it is possible to define whether the image memory is enabled at all and whether all images or only those from bad tests should be stored. This allows the systematic investigation of the causes of sporadic bad tests that may occur.

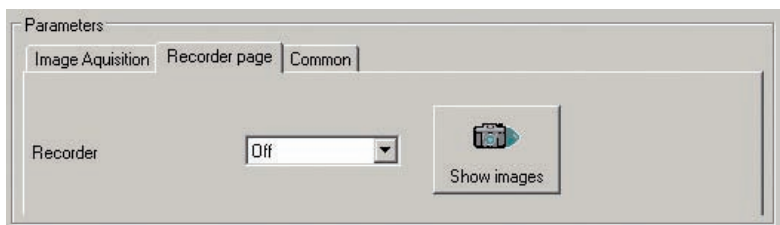

When the **Show images** button is pressed, the images stored on the sensor are transferred to the PC and can be viewed.

2012.10.20.10-04

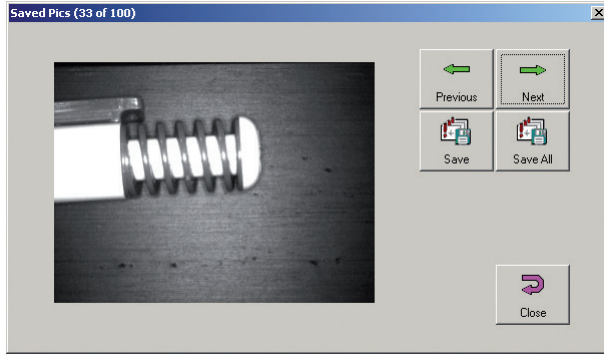

Individual images or all images on the hard drive can be saved by pressing **Save** or **Save all**.



Caution!

When exiting the dialog, all images on the sensor will be deleted.

7.9.3 Common

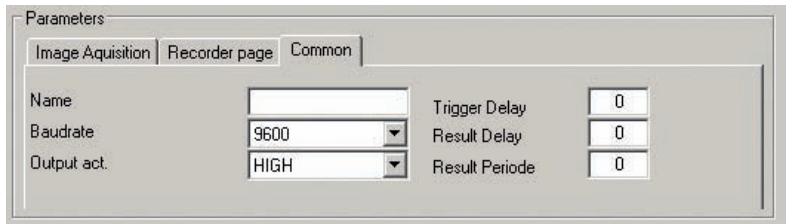

Name: A name can be allocated to each sensor and is used to display the sensor in the sensor finder, for example.

Baud rate: Transfer speed of the serial interface.

Output activity: Polarity (high active or low active) of the output signals RESULT and POSITION.



Caution!

The LED indicators in the user interface and on the sensor always operate as high active, irrespective of the preset output polarity.

Trigger delay: Time period by which the image capture is delayed after the trigger impulse is received at the input TRIGGER (entry of 0 - 10000 corresponds to 0 - 10000 ms).

Result delay: Time period after which the outputs RESULT and POSITION are activated at the earliest after receiving the trigger impulse (entry of 0 - 10000 corresponds to 0 - 10000 ms).

Result period: Time period during which the output READY remains "low" after activation of the outputs RESULT and POSITION (entry of 0 - 10000 corresponds to 0 - 10000 ms).

7.10 Test functions

VOS3-Config provides two test functions to check and analyze the sensor function.

7.10.1 Single test

The **Single test** button at the bottom of the "Checks" area is used to test the individual checks. With this button, the currently displayed check or position correction (the tab "on top") is applied to the image currently in the display. No new image will be captured for this purpose. (If desired, new images can be captured and displayed using the "Live display" button). The test results are displayed numerically on the check tab and the image display shows the processed pixels, rectangles or crosses.

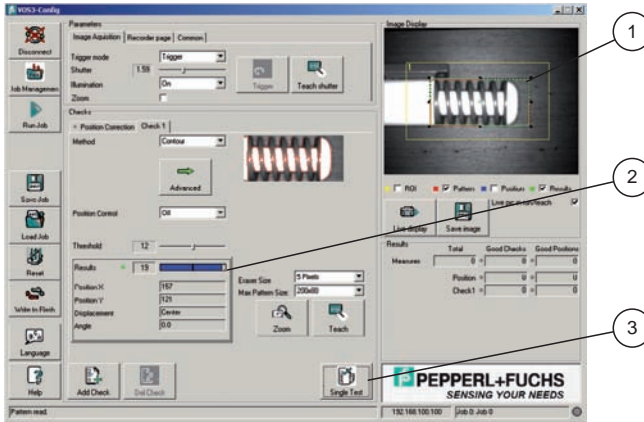

Figure 7.5: Functions for single test

- 1 Displayed search result (light green)
- 2 Result display
- 3 **Single test** button

7.10.2 Complete test runs

After pressing the button **Run job** in the button area, complete test runs will be executed, i.e., images will be captured independently or via a trigger and all checks will be applied to them. (Trigger impulses can be simulated using the corresponding button in the "Image acquisition" tab, see chapter 7.9.1).

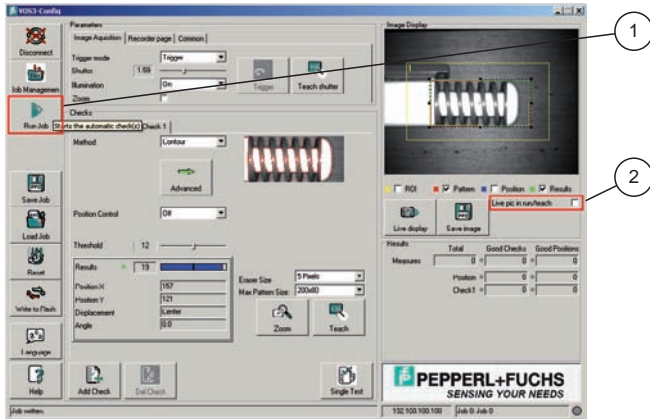

Figure 7.6: Test function, complete test run

- 1 Button for starting test runs
- 2 "Image display during test" check box

If the **Live pic in run/teach** check box is enabled, the images captured during the test are transferred from the sensor to the PC and displayed. Otherwise the images are not transferred, i.e., the last image remains in the display during the test.



Caution!

The overlaid images may not then match the ("old") image underneath.

During the test, the results are displayed in the "Results" area and the processing times in the status bar:

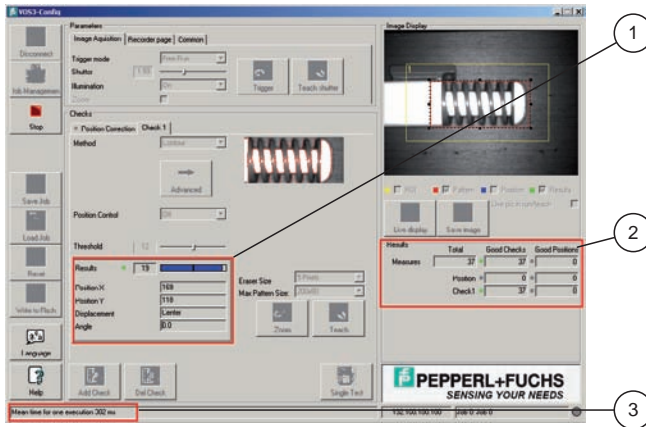

Figure 7.7: Test function and display of results

- 1 Display of check results
- 2 Number of executions and "good" checks
- 3 In continuous operation, the processing times are displayed in the status bar.

7.11 Job manager

Jobs are created via the Job manager button.

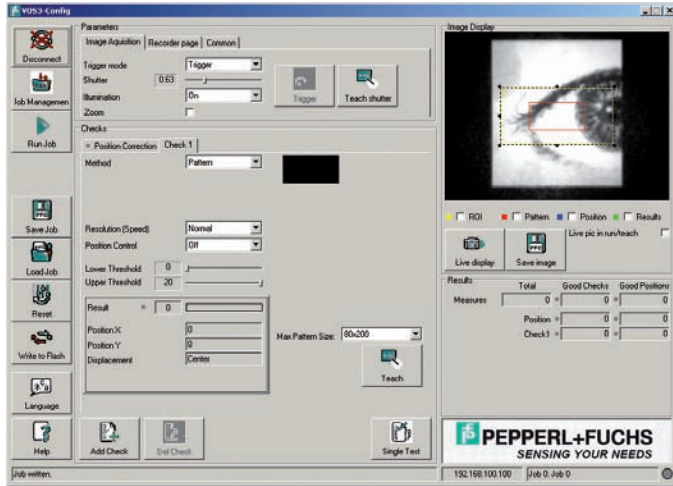

Figure 7.8: Opening the job manager

Pressing the "Job manager" button in the main menu opens the following modal dialog box:

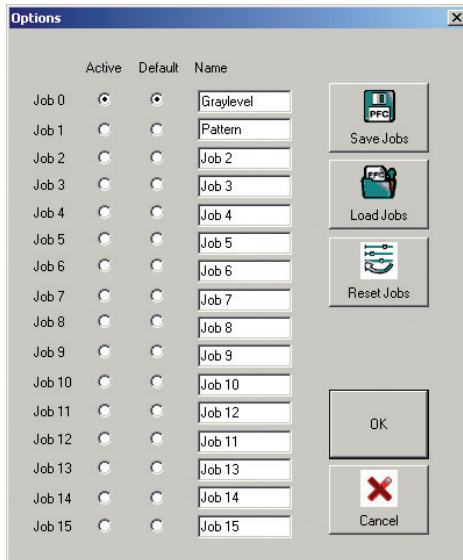

Figure 7.9: Job manager



In this box, you can assign different names to the individual jobs and the name and number of the current bank are displayed in the status bar.

You can select either the current ("Active") job or the job that becomes active after a reset ("Default").

The **"Save Jobs"** and **"Load Jobs"** buttons in the job manager menu are used to load and save all banks. These groups of jobs are saved on the PC as *.pfs files (**"Pepperl+Fuchs Sensor Files"**) to distinguish them from *.pfc files, which contain individual jobs.

The **"Reset jobs"** button sets all jobs for a sensor to the default job and resets the names to "Job 0" to "Job15".

The **"Load job"**, **"Save job"**, **"Write to Flash"** and **"Reset"** buttons in the main menu of VOS3-Config software only relate to the active job.

With new sensors, job 0 is always active and the name is preset to "Job 0".

The job manager menu can be accessed in both administrator mode and user mode.



Saving jobs to the sensor memory bank

To save a job to the memory bank in a sensor, proceed as follows:

1. Before a new job can be parameterized in the VOS3-Config software and preset as one of 16 configurations in the sensor, the job manager must be opened.

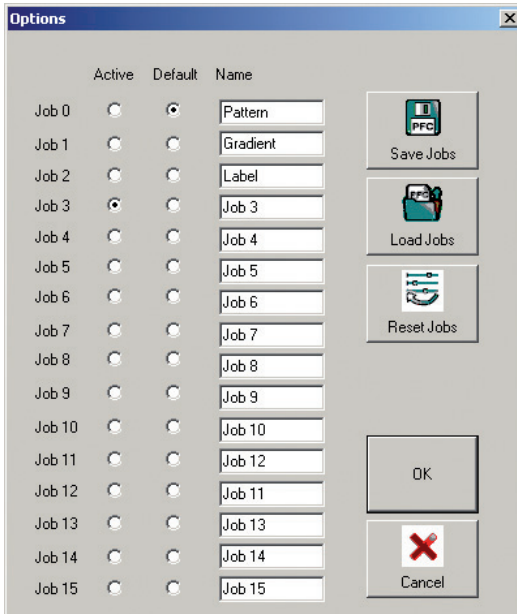

Figure 7.10: Saving a job in the job manager

2. Select the required memory bank with "Active."
3. Then press OK to confirm this selection.
The job manager closes again automatically.
4. You can now create a new job or modify an existing one in the parameterization environment in the usual way.
The new configuration (job) is then saved automatically in the selected bank.
5. To save the job, you must first open the job manager again.
However, before the job manager opens, you must confirm the following prompt asking you whether you wish to save the job under the selected number.

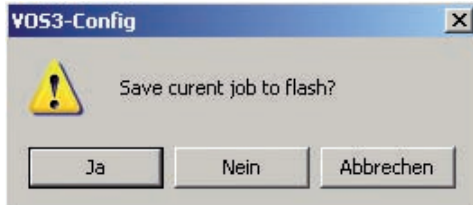

Figure 7.11: Saving a job

6. The name of the job can be entered or modified at a later time and must also be confirmed with OK.
7. If you previously selected a memory bank that already contains a saved job, the new job overwrites the old job.



Retrieving jobs from the sensor memory bank

To activate one of the 16 jobs stored in the sensor, proceed as follows:

1. Set the required job number to "Active" in the job manager.
2. Then press OK to confirm.
The job is now present in the parameterization interface and can be changed or operated in test mode.



Saving job modifications

If a job has been modified and you wish to save the modifications in the memory bank, proceed as follows:

1. Open the job manager again.
Before the job manager opens, the following message appears, asking you whether you wish to save the modifications in the currently active job.

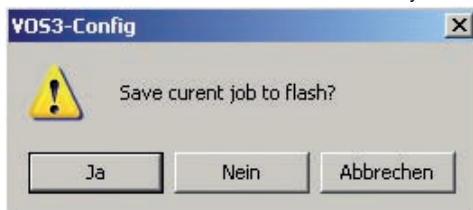

Figure 7.12: Saving job modifications

2. Confirm the prompt by pressing **YES** or **NO**.

Pressing **YES** saves the job in the current bank and opens the job manager. All available functions can then be used (e.g., opening other jobs).

If you confirm this prompt with **NO**, the job manager window opens. If you select another job with "Active" in order to open it, for example, another prompt appears asking you whether you would like to save the modifications to the previous job:



Figure 7.13: Actually saving job modifications

3. Confirm the prompt by pressing **YES** or **NO**.

If you press **YES**, the current job is saved in the active bank first, and then the newly selected job opens.

If you press **NO**, the other required job opens in the parameterization interface.



Save all Jobs

To save all jobs, proceed as follows:

1. Pressing the "Save all" button.

A conventional Windows dialog box is opened for saving all the jobs on the PC.

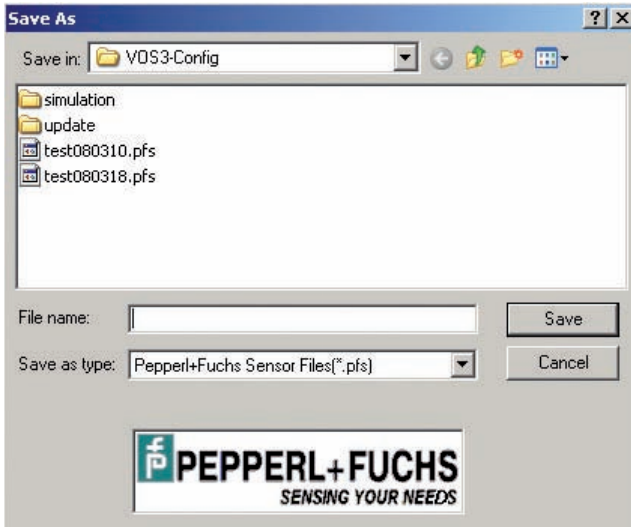

Figure 7.14: Saving job as

2. Now the target directory can be selected for saving the *.pfs file.



Delete all jobs in the sensor

To delete all jobs, proceed as follows:

1. Pressing the "Reset jobs" button
deletes all 16 jobs stored in the sensor. This procedure is confirmed with the prompt shown.

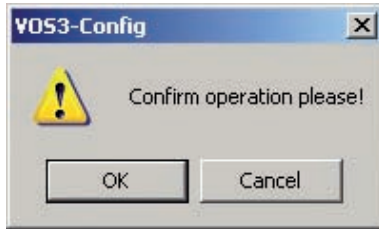

Figure 7.15: Deleting all jobs in the sensor

2. Press OK to confirm the deletion process.
All the jobs are then deleted and the default names entered in the banks.



Load all jobs from the PC

To load all jobs from the PC, proceed as follows:

1. Pressing the "Load all" button
opens a Windows dialog box, in which a search for job files *.pfs can be run.

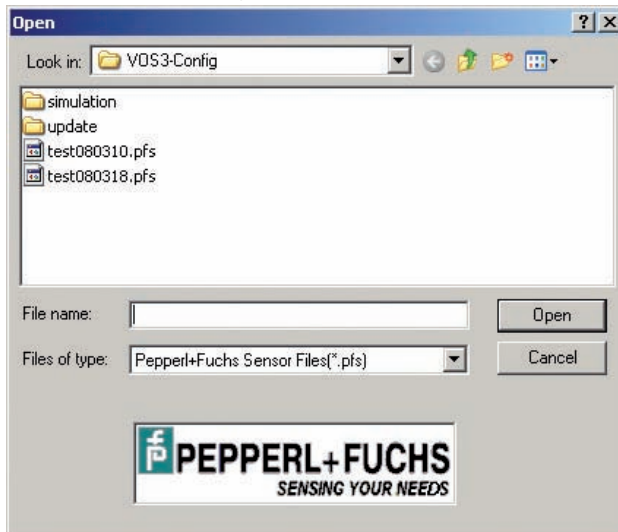

Figure 7.16: Loading all jobs to the PC

2. The desired file can then be loaded into the sensor.



7.12 Position detection and correction

Position detection is used to determine the position of the object to be evaluated in the image. Even with triggered image capture, the objects in the image do not always appear in exactly the same position due to mechanical tolerances during the infeed, for example. The positions of the evaluation area of the individual checks must then be corrected after each image capture.

Example: Checking date and number imprint. The working areas are corrected in relation to the position of the logo:

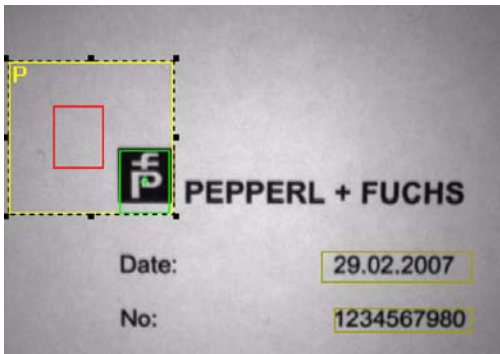
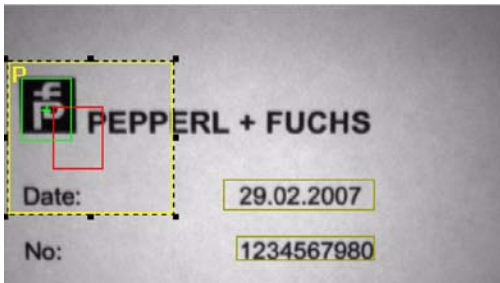
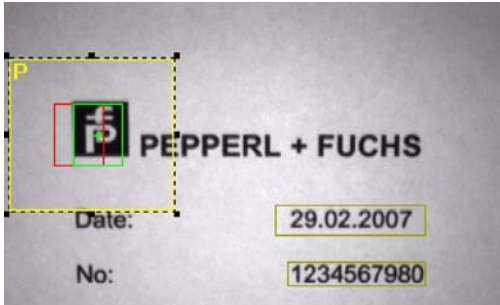

The deviation of an object from a taught position is calculated to allow the evaluation areas of the subsequent checks in the image to be moved accordingly. In addition, the calculated position is output via the serial interface or the network.

The following methods are available for position detection:

- None (no position correction takes place)
- Pattern
- Blob
- Edge detection
- Contour

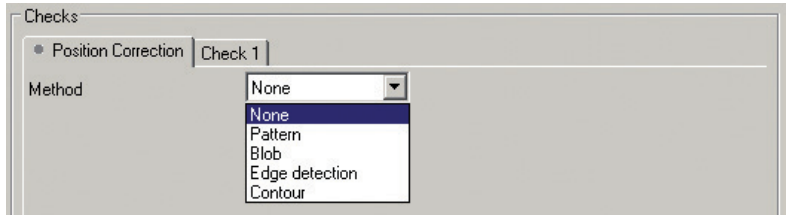
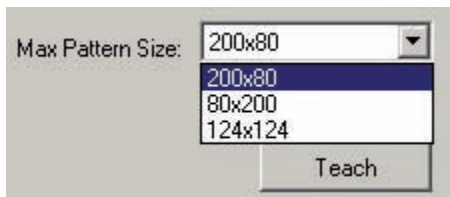

Figure 7.17: Position correction tab

7.12.1 Pattern

During the teach-in process, a pattern is marked that must be found again in the search area. Marking is performed using a red rectangular box that can be varied in position and size.



The pattern size is restricted to 16,000 pixels that can be either arranged in a rectangular (200x80 or 80x200) or square (124x124) shape.

The geometric layout is predefined as **Max. pattern size:**

The dimensions of the red rectangle in the image display window are limited to the selected maximum pattern size, i.e., for a setting of 200 x 80, the red rectangle may have a maximum width of 200 pixels and a maximum height of 80 pixels.

The search area is marked with a yellow box. In this search area, the model is moved pixel by pixel in the X and Y direction and the difference between the current image and the model calculated at each position. The model is found in the search area when the difference falls below the specified threshold value.

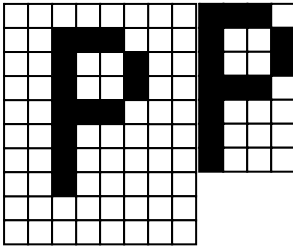

Setup template

Generated model

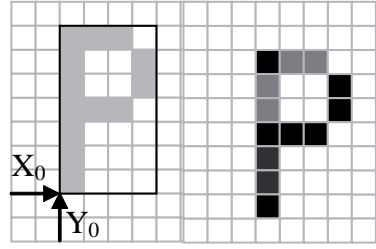

Target position

Captured image

The model is moved pixel by pixel over the captured image and the difference between image and model is calculated:

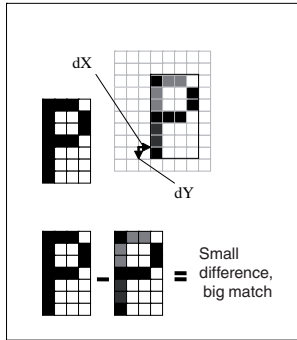
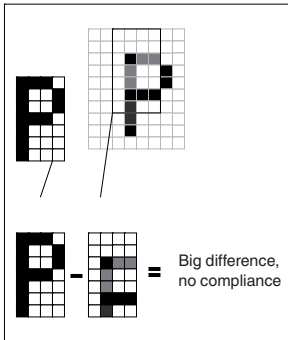
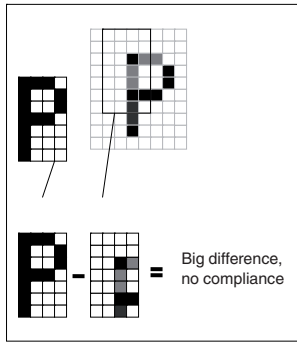
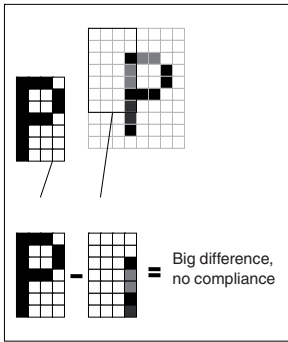

When the test has finished, the result is displayed as a value for the match between the found and the saved pattern. The permitted range for this result value is defined using the **Lower threshold** and **Upper threshold** sliders. In other words, the check provides a "good" result if the result value is within the permitted range and a "bad result" if it is outside the permitted range.

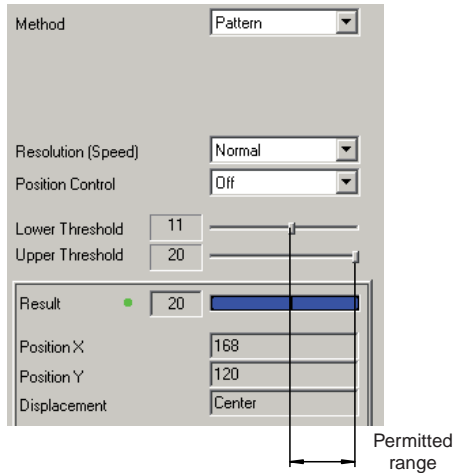

The accuracy of the pattern comparison can be set to normal, coarse or fine using the **Resolution** list field. Coarse resolution means shorter processing times with less accuracy and fine resolution means greater accuracy with longer processing times.

The position of the center point of the found pattern is also shown in the image. The reference point for this position is the top left image corner.

The pattern comparison can only be used to compensate for movements, not for rotation. Movements of max. 5° are tolerated and result in lower match values but cannot be calculated. The main benefit of the pattern comparison method is the simple teach-in. A disadvantage is the comparably high sensitivity to interference in noisy images and differing brightness.

The method is only suitable for patterns which remain mostly the same during the check as is normally the case e.g., in print processes. The contour method would be more suitable for applications where the objects under test can change their appearance without this being a test criterion. This kind of behavior is often found in metal components whose surfaces can differ without the relevant dimensions changing.

7.12.2 Blob

Here the search area is binarized, i.e., a gray value threshold is used to determine which pixels belong to the object and which belong to the background. You also have the option of selecting whether the search should find dark objects on a light background or vice versa. The center of gravity area of the largest found object is then calculated and the position of the object is used to determine any movement compared to the taught position.

The binarization process is displayed in the image when the **Single test** button is pressed.

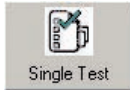

The marking color can be selected.



Figure 7.18: Image representation and marking color

The gray value threshold must be set in such a way that the object is clearly separated from the background:

		
<input checked="" type="checkbox"/> Position Correction Check 1 Method Blob Grey threshold 27 Blob direction dark blob	<input checked="" type="checkbox"/> Position Correction Check 1 Method Blob Grey threshold 129 Blob direction dark blob	<input checked="" type="checkbox"/> Position Correction Check 1 Method Blob Grey threshold 77 Blob direction dark blob
Threshold too low	Threshold too high	Correct threshold

Table 7.1: Gray threshold values

The blob method can be used if the background is homogeneous and the gray values of the object differ markedly from those of the background.

In this case, the blob method has advantages over e.g., the **pattern** method if the objects to be found are not of uniform size.

7.12.3 Edge detection

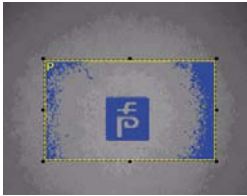
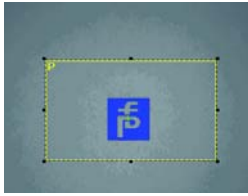
A horizontal or vertical search is run for the first edge in a defined horizontal and a vertical search area. A search direction, edge type, edge filter, threshold value and the number of lines in the search area can be specified for each search area.

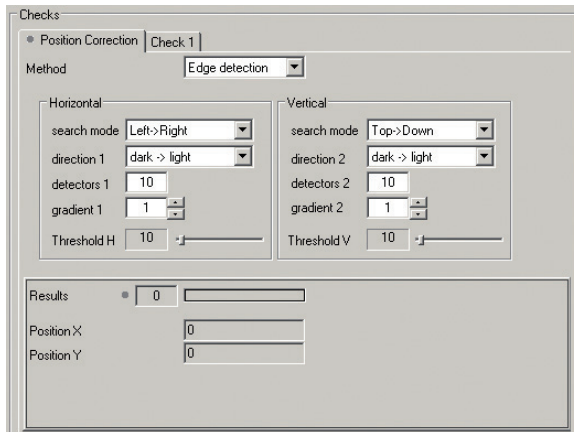
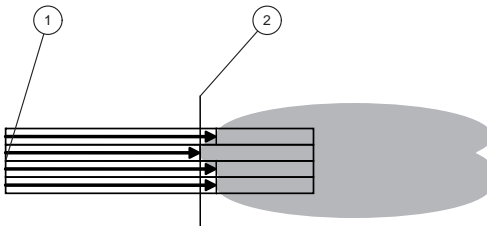

Figure 7.19: Edge detection tab

- Search mode: From **left to right** or vice versa in the horizontal search area or **from top to bottom** or vice versa in the vertical search area. "**OFF (fixed in center)**" can also be selected. Edge detection does not take place in this case, but the center of the search area is considered as a fixed result. The scan can only run in one direction (either horizontally or vertically).
- Direction: Edge type: Light/dark or dark/light (viewed in the direction of search).
- Detectors: Number of strips into which the search area is divided.
- Gradient: Number of pixels to the left and right of the edge which are included in the intensity calculation in order to filter out small noise pixels. This helps to suppress incorrect edge detection of individual pixels.
- Threshold: Threshold value for the edge intensity.

Within the search area, scanning takes place in all strips independently of one another and the result of the strip is accepted where an edge is first found, in other words, the "shortest" result viewed in the direction of search:



- 1 Number of detectors (= 4 strips)
- 2 Result

The edge detection function can be checked using "Single test" (in the current image) or "Run/stop job" (with new image capture).

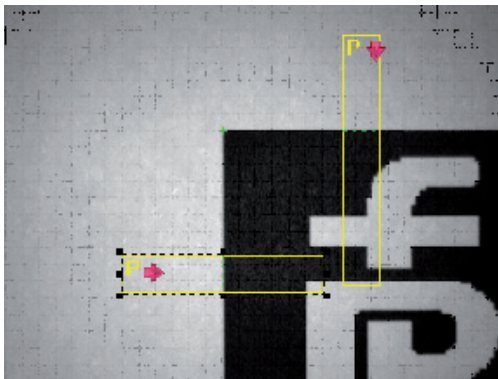

During the test the following elements are displayed in the image:

- The search areas marked with "P" as yellow rectangles
- The search directions in the areas as magenta colored arrows
- The found edges as green dotted lines in the search areas
- The scanned position as a green cross

The scanning method is suitable for objects whose shape is not defined exactly or which are not completely within the image field, i.e., are "cut off" with only the object edges visible. The objects must only be clearly distinctive from the background inside the search area, the background does not necessarily have to be homogeneous.

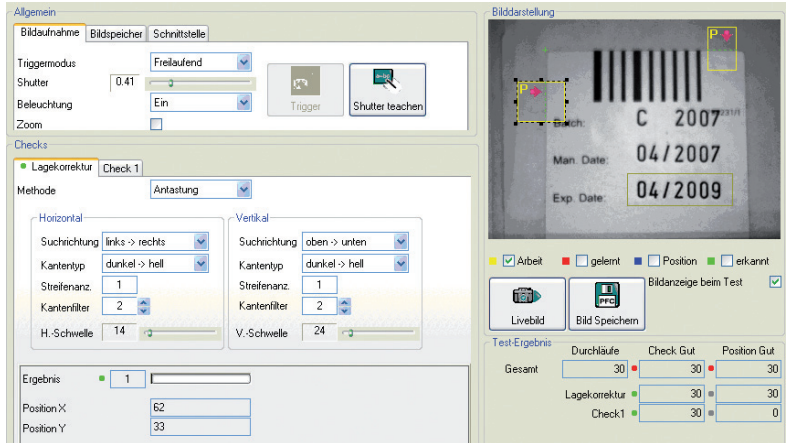

Example: Scanning of the label with subsequent gradient check to check whether the expiration date has been printed.

7.12.4 Contour

During the contour comparison, contours are calculated in the pattern and in the image first, and then the image contours found are compared with the pattern contours:

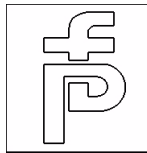

Control elements on the Check tab for the **Contour** evaluation method:

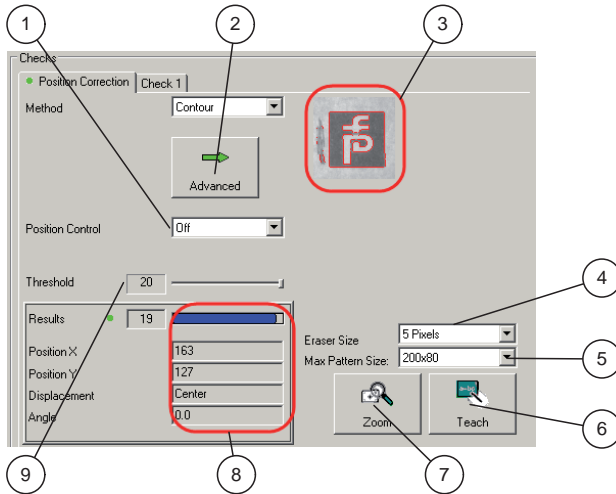
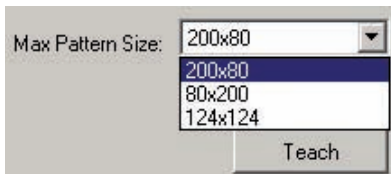

Figure 7.20: Elements from the **Contour** evaluation method

- 1 Position test setting
- 2 Button for advanced settings
- 3 Taught contour
- 4 Eraser size setting for editing the target contour
- 5 Pattern size setting
- 6 Button for teaching in the target contour
- 7 Button for editing the contour in magnified form
- 8 Display of test results
- 9 Result threshold setting

For the teach-in process, an image area is marked which must be found again in the search area. Marking is performed using a red rectangular box which can be varied in position and size.

The pattern size is restricted to 16,000 pixels that can be either arranged in a rectangular (200x80 or 80x200) or square (124x124) shape. The geometric layout is predefined as **Max. pattern size**:



The dimensions of the red rectangle in the image display window are limited to the selected maximum pattern size, i.e., for a setting of 200 x 80, the red rectangle may have a maximum width of 200 pixels and a maximum height of 80 pixels.

After teaching a contour, all calculated contours are initially displayed. This view can also be enlarged by pressing the **Edit** button. Parts of the contour that you do not wish to save as a model can be deleted directly in the displayed image using the eraser function. Several sizes of eraser are available.

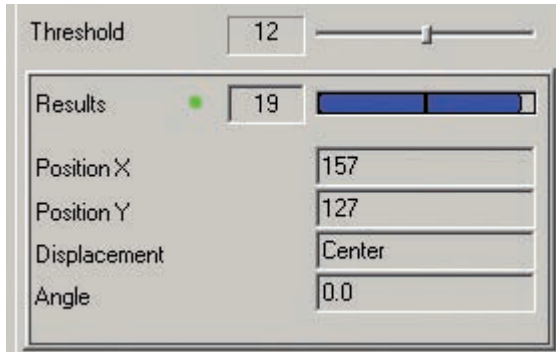

Figure 7.21: Contour after teach-in



Figure 7.22: Edited contour

The settings can be tested using the **Single test** button. When the tests have finished, the result is displayed in the form of a match between the found and the saved contours. The minimum value for this result is defined using the **Threshold** slider. The check returns a "good" result if the result is above the threshold value.



The position of the center point of the found contour is also shown in the image. The reference point for this position is the top left image corner.

The contour under test may not only have moved compared to the taught contour, rotations are also permitted (unlike in the pattern comparison). For this reason, the rotation angle is displayed during the contour check in addition to the movement in the X and Y direction.

The functionality of the contour check can be influenced by additional parameters for optimum adaptation to a task. These can be accessed by pressing the **Advanced** button:

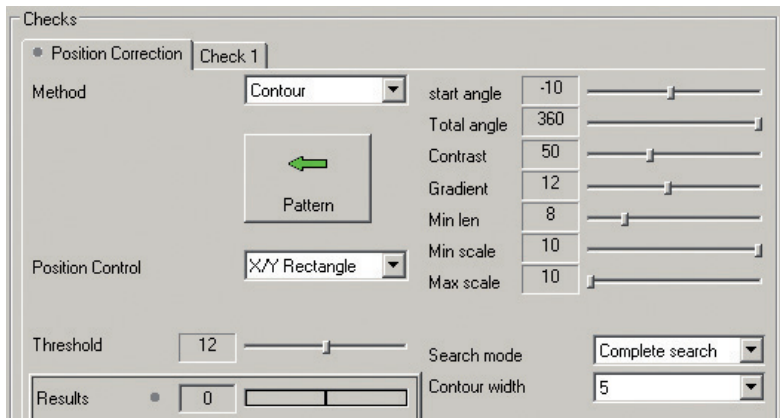

Start angle: Start values for the permitted rotation between taught and found contour, setting range of -180° to 179°.

Total angle: Area for the permitted rotation of the found contour to the taught-in contour, setting range of 0° to 360°.

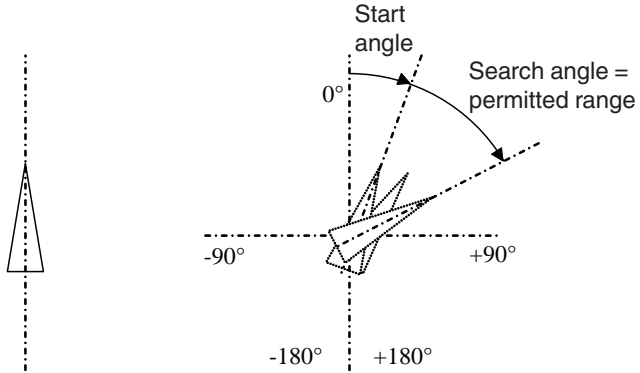

saved outline

detected outline

Contrast: Edge contrast: Minimum gray value difference of the contour edges

Gradient: Edge gradient: Minimum "sharpness" of the contour edges

Min len.: Contour length: Minimum length of the contour segments in pixels

Min. scale, Max. scale: Minimum and maximum scaling factor. These values represent the tolerated scaling factor for the size variation of the pattern contour.

The adjustment ranges are:

Min. scale: 5-10, corresponds to factor 0.5 to 1.0

Max. scale: 10-15, corresponds to factor 1.0 to 1.5



Taught contour (scaling 1.0)



Scaled with factor 0.67



Scaled with factor 1.35

Search mode: "Complete search" / "Until first OK":

In "Until first OK", a search for the pattern contour is run in the working area until the minimum match defined by the threshold value has been found. Then the search is cancelled.

In "Complete search", a search is run through the complete working area and the object with the best match to the pattern contour selected.

Contour width: The width of the "tube" around the pattern contour within which the contour to be searched for may move (3, 5, 7, 9 pixels can be set):

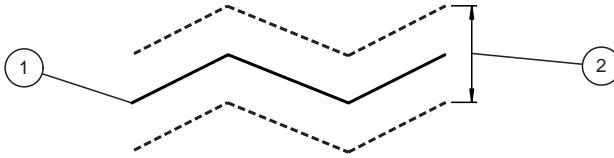

- 1 Pattern contour
- 2 Tolerance width



The advanced contour parameters can be reset to the factory default settings by pressing the "Reset" button.
Caution: The previously set values will be lost.

The contour calculation requires a reasonable amount of computing time. For this reason, the area selected for comparison should be as small as possible in the interest of fast processing. The selected minimum values for edge contrast, edge gradient and contour length should also be as large as possible and the scaling range as small as possible (Min. scale = 9-10, Max. scale = 10-11).

7.12.5 Notes on using position correction

If position correction is enabled, this is the first processing step in the sensor. The other evaluations build on the result of the position correction.

For the setup process, this means that the working areas of the checks can only be modified once the position correction has terminated without errors. If the position correction fails, the working areas of the checks are blocked, i.e., they can neither be moved nor changed in size.

The message "Editing blocked! Check position correction ..." shown in the image below indicates that a failure has occurred:

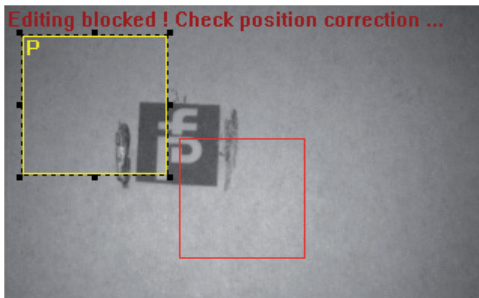

Position correction must function correctly before the working areas can be modified in such cases.

The failure can have two causes:

- The position detection itself could not find the position of the taught object.
- One or more working areas are moved out of the image field by the calculated position movement.

First the function of the position detection must be checked and optimized, if necessary. The corresponding record tab indicates whether position detection worked correctly:

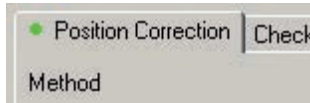

Figure 7.23: Position detection successful

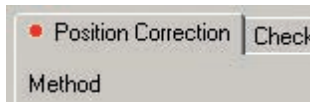

Figure 7.24: Position detection failed

If the position detection failed (red LED on the record tab) it must first be revised so that the taught object is found reliably.

If "Please check position correction" appears in spite of successful position detection (green LED on the record tab), this means that the working areas of one or several checks would be moved outside the image field by the position movement. In these cases, the following procedure is recommended:

1. Disable position correction.
2. Adjust working areas of the checks so that they are not moved outside the image.
3. Enable position correction again.

If position correction is unsuccessful in automatic mode, the output for the overall result (RESULT) is set to "Low" ("bad" result).

7.13 Attribute evaluations ("Checks")

After the position correction, one check is carried out in the VOS302 and up to six checks in the VOS312. For every check the following methods are available for selection:

- Pattern comparison
- Contrast evaluation
- Gray value evaluation ("count pixels")
- Contour comparison
- Gradient evaluation ("count transitions")

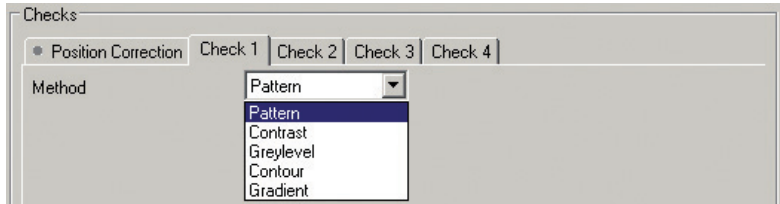

The individual checks are carried out separately and consecutively. Each check produces either a "good" or "bad" result, the overall result is formed by an AND combination of the checks. In other words, the overall result is only "good" if all checks have returned a "good" result.

For all evaluation methods, an evaluation area is defined in the image in which the method is to be applied. The position of the evaluation area is corrected by the result of the position measurement.

7.13.1 Pattern

During the teach-in process, a pattern is marked that must be found again in the search area. Marking is performed using a red rectangular box that can be varied in position and size.

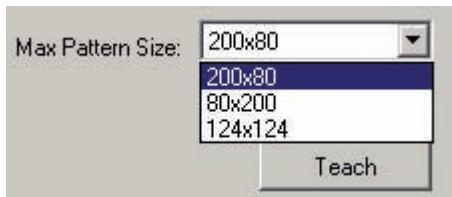

The pattern size is restricted to 16,000 pixels that can be either arranged in a rectangular (200x80 or 80x200) or square (124x124) shape.

The geometric layout is predefined as **Max. pattern size**:

The dimensions of the red rectangle in the image display window are limited to the selected maximum pattern size, i.e., for a setting of 200 x 80, the red rectangle may have a maximum width of 200 pixels and a maximum height of 80 pixels.

The search area is marked with a yellow box. In this search area, the model is moved pixel by pixel in the X and Y direction and the difference between the current image and the model calculated at each position. The model is found in the search area when the difference falls below the specified threshold value.

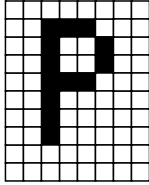

Setup template

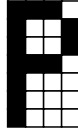

Generated model

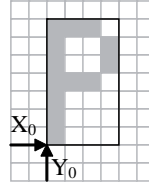

Target position

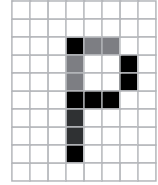

Captured image

The model is moved pixel by pixel over the captured image and the difference between image and model is calculated:

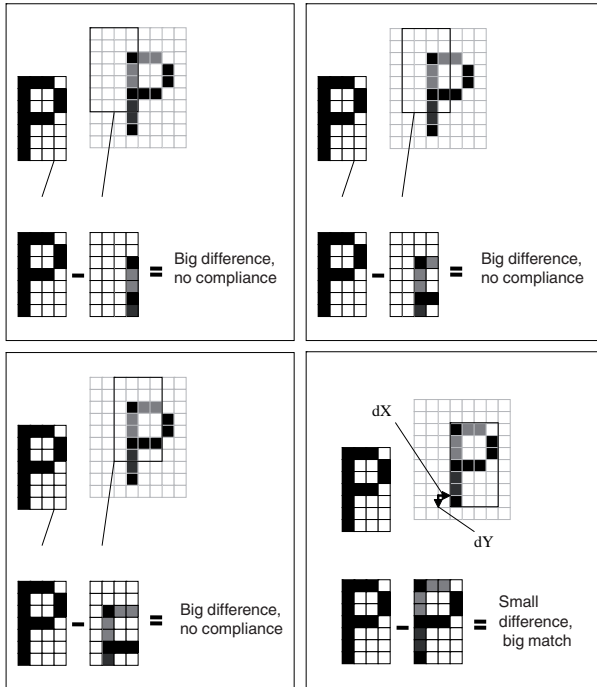

When the test has finished, the result is displayed as a value for the match between the found and the saved pattern. The permitted range for this result value is defined using the **Lower threshold** and **Upper threshold** sliders. In other words, the check provides a "good" result if the result value is within the permitted range and a "bad result" if it is outside the permitted range.

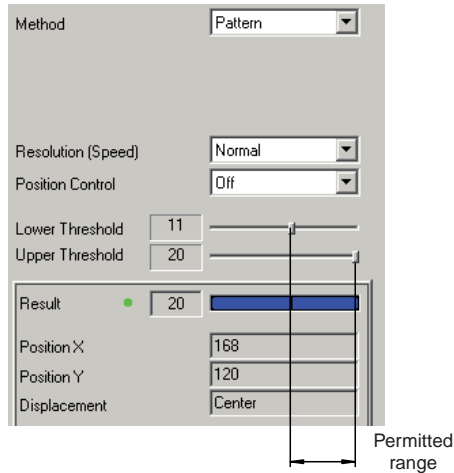

The accuracy of the pattern comparison can be set to normal, coarse or fine using the **Resolution** list field. Coarse resolution means shorter processing times with less accuracy and fine resolution means greater accuracy with longer processing times.

The position of the center point of the found pattern is also shown in the image. The reference point for this position is the top left image corner.

The pattern comparison can only be used to compensate for movements, not for rotation. Movements of max. 5° are tolerated and result in lower match values but cannot be calculated. The main benefit of the pattern comparison method is the simple teach-in. A disadvantage is the comparably high sensitivity to interference in noisy images and differing brightness.

The method is only suitable for patterns which remain mostly the same during the check as is normally the case e.g., in print processes. The contour method would be more suitable for applications where the objects under test can change their appearance without this being a test criterion. This kind of behavior is often found in metal components whose surfaces can differ without the relevant dimensions changing.

7.13.2 Contrast

The **Contrast** evaluation method defines a measure for gray value distribution in the evaluation area. A largely homogeneous image has a low contrast value and an image with strongly differing gray values a high value:

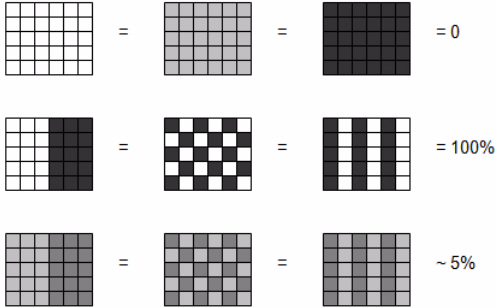

The calculated value is compared with a specified contrast threshold. If the contrast value is below the threshold, the result of the check is "bad," if the value is above the contrast threshold, the result is "good."

7.13.3 Grayscale value

With the method **Gray value** ("count pixels"), an evaluation area is specified in which a binarization is carried out using the specified gray value threshold. In other words, an image is generated in which the individual pixels can only have one of the two states "below gray value threshold" or "above gray value threshold."

The pixels "above the gray value threshold" are then counted and a check carried out to determine whether the calculated number is within the range specified by the **Lower threshold** and **Upper threshold** sliders. If this is the case, the result of the check is "good," otherwise it is "bad." The sliders have a logarithmic distribution that allows the definition of extremely precise limits when there is only a small number of gray values. With a larger number of gray values, the value is interpolated so the value 897 would appear as 896, for example.

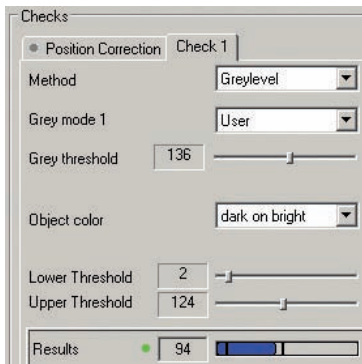

The following parameters can be set:

Threshold adjustment: Manual or automatic gray value threshold adjustment. With manual adjustment, the gray value threshold is defined using the **Gray threshold** slider and with automatic adjustment, the slider is disabled and the threshold is calculated automatically from the image brightness values.

Gray threshold: Binarization gray value, the pixels with gray values higher than this value are counted, the remaining pixels are not. The slider is only active in manual threshold value mode.

Lower threshold: Minimum number of pixels with gray values higher than the gray value threshold.

Upper threshold: Maximum number of pixels with gray values higher than the gray value threshold.

The binarization process is displayed in the image when the **Single test** button is pressed.

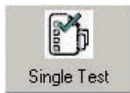

The marking color can be selected.

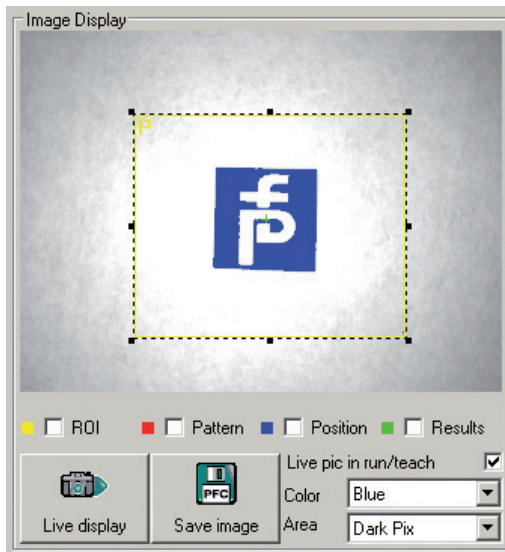
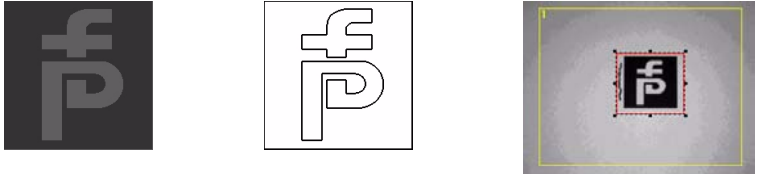

Figure 7.25: Image representation and marking color

7.13.4 Contour

During the contour comparison, contours are calculated in the pattern and in the image first, and then the image contours found are compared with the pattern contours:



Control elements on the Check tab for the **Contour** evaluation method:

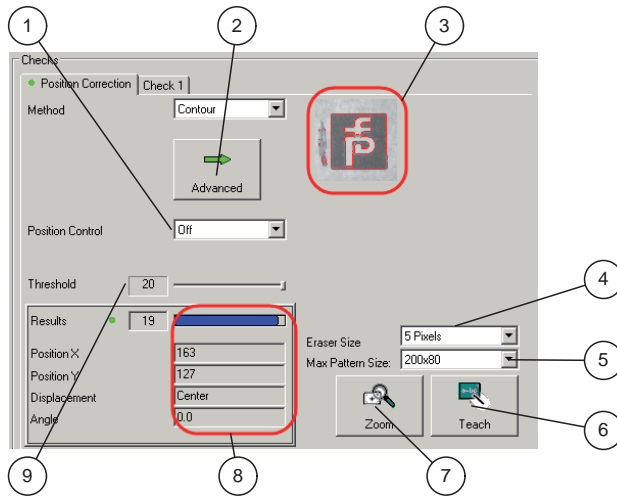
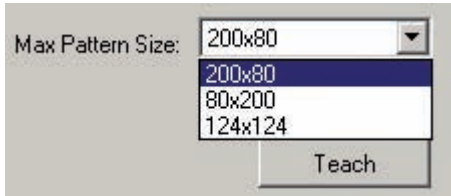

Figure 7.26: Elements from the **Contour** evaluation method

- 1 Position test setting
- 2 Button for advanced settings
- 3 Taught contour
- 4 Eraser size setting for editing the target contour
- 5 Pattern size setting
- 6 Button for teaching in the target contour
- 7 Button for editing the contour in magnified form
- 8 Display of test results
- 9 Result threshold setting

For the teach-in process, an image area is marked which must be found again in the search area. Marking is performed using a red rectangular box which can be varied in position and size.

The pattern size is restricted to 16,000 pixels that can be either arranged in a rectangular (200x80 or 80x200) or square (124x124) shape. The geometric layout is predefined as **Max. pattern size**:



The dimensions of the red rectangle in the image display window are limited to the selected maximum pattern size, i.e., for a setting of 200 x 80, the red rectangle may have a maximum width of 200 pixels and a maximum height of 80 pixels.

After teaching a contour, all calculated contours are initially displayed. This view can also be enlarged by pressing the **Edit** button. Parts of the contour that you do not wish to save as a model can be deleted directly in the displayed image using the eraser function. Several sizes of eraser are available.

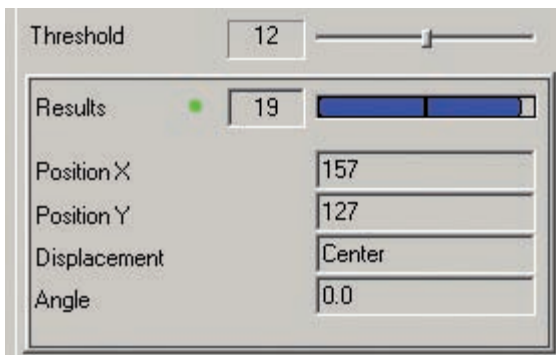

Figure 7.27: Contour after teach-in



Figure 7.28: Edited contour

The settings can be tested using the **Single test** button. When the tests have finished, the result is displayed in the form of a match between the found and the saved contours. The minimum value for this result is defined using the **Threshold** slider. The check returns a "good" result if the result is above the threshold value.



The position of the center point of the found contour is also shown in the image. The reference point for this position is the top left image corner.

The contour under test may not only have moved compared to the taught contour, rotations are also permitted (unlike in the pattern comparison). For this reason, the rotation angle is displayed during the contour check in addition to the movement in the X and Y direction.

The functionality of the contour check can be influenced by additional parameters for optimum adaptation to a task. These can be accessed by pressing the **Advanced** button:

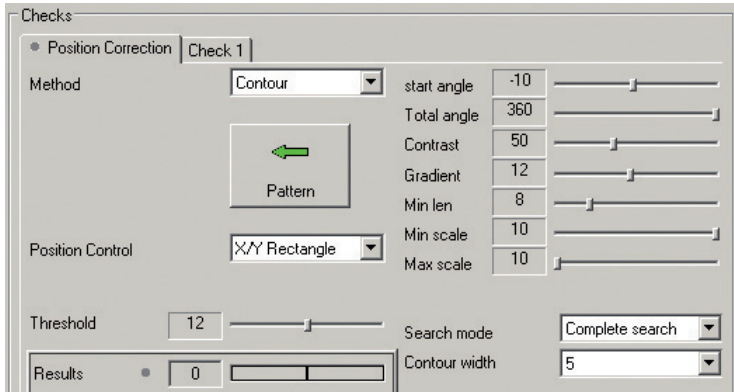

Start angle: Start values for the permitted rotation between taught and found contour, setting range of -180° to 179°.

Total angle: Area for the permitted rotation of the found contour to the taught-in contour, setting range of 0° to 360°.

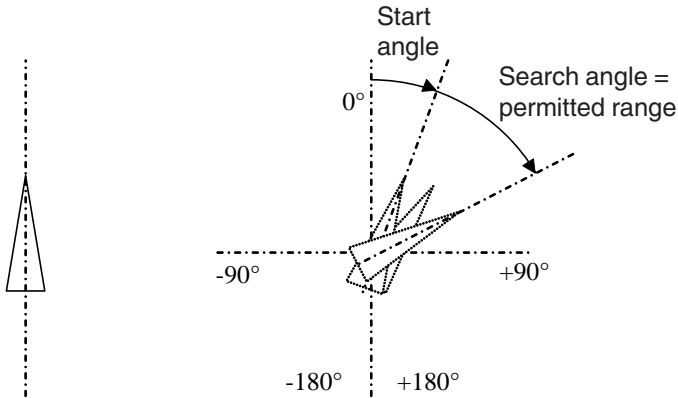

saved outline

detected outline

Contrast: Edge contrast: Minimum gray value difference of the contour edges

Gradient: Edge gradient: Minimum "sharpness" of the contour edges

Min len.: Contour length: Minimum length of the contour segments in pixels

Min. scale, Max. scale: Minimum and maximum scaling factor. These values represent the tolerated scaling factor for the size variation of the pattern contour.

The adjustment ranges are:

Min. scale: 5-10, corresponds to factor 0.5 to 1.0

Max. scale: 10-15, corresponds to factor 1.0 to 1.5



Taught contour (scaling 1.0)

Scaled with factor 0.67

Scaled with factor 1.35

Search mode: "Complete search" / "Until first OK":

In "Until first OK", a search for the pattern contour is run in the working area until the minimum match defined by the threshold value has been found. Then the search is cancelled.

In "Complete search", a search is run through the complete working area and the object with the best match to the pattern contour selected.

Contour width: The width of the "tube" around the pattern contour within which the contour to be searched for may move (3, 5, 7, 9 pixels can be set):

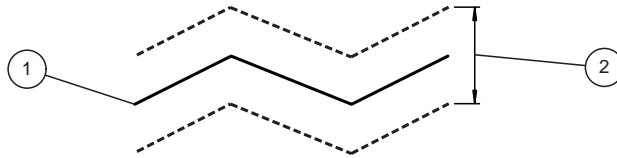

- 1 Pattern contour
- 2 Tolerance width



The advanced contour parameters can be reset to the factory default settings by pressing the "Reset" button.

Caution: The previously set values will be lost.

The contour calculation requires a reasonable amount of computing time. For this reason, the area selected for comparison should be as small as possible in the interest of fast processing. The selected minimum values for edge contrast, edge gradient and contour length should also be as large as possible and the scaling range as small as possible (Min. scale = 9-10, Max. scale = 10-11).

7.13.5 Gradient

With gradient ("count transitions"), the evaluation area of the image is first filtered in such a way that an edge image is created, i.e., light/dark and dark/light transitions are filtered out and shown in light, while areas without transitions remain dark:

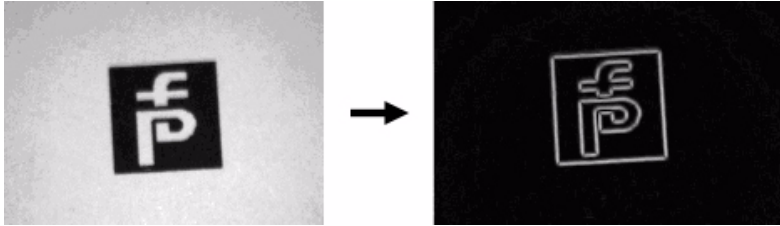
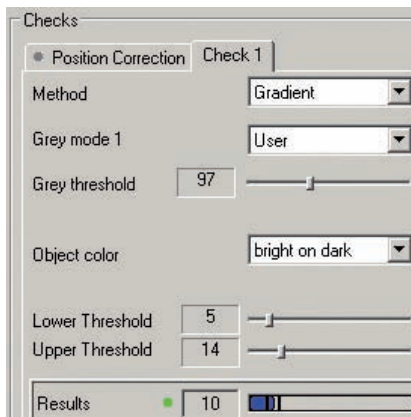

Figure 729: Captured image and image after edge filtering

Here the brighter the appearance of the edges in the filtered image, the steeper the gray value increase, i.e., the sharper the edge appears.

In the filtered image, the pixels are counted whose brightness is above the specified gradient threshold and a check is carried out to determine whether the calculated number is within the area specified by the **Lower threshold** and **Upper threshold** sliders. If this is the case, the result of the check is "good," otherwise it is "bad." The sliders have a logarithmic distribution that allows the definition of extremely precise limits when there is only a small number of gray values. With a larger number of gray values, the value is interpolated so the value 897 would appear as 896, for example.

The following parameters can be set:



Threshold adjustment: Manual or automatic gray value threshold adjustment. With manual adjustment, the gradient threshold is defined using the slider **Gradient threshold** and with automatic adjustment, the slider is disabled and the threshold is calculated automatically from the image brightness values.

Gradient threshold: Binarization value, the pixels with gradient values higher than this value are counted, the remaining pixels are not. The slider is only visible in manual threshold value mode.

Lower threshold: Minimum number of pixels with gray values higher than the gradient threshold.

Upper threshold: Maximum number of pixels with gray values higher than the gradient threshold.

Unlike the "Contrast" evaluation method, in **Count transitions** the local relationships between the light/dark or dark/light differences are also taken into account, whereas in "Contrast" only the pure gray value numbers matter.

Similar to the **Gray value** method, with "Gradient" the evaluation can also be displayed in the image by pressing the **Single test** button. The edges are then shown in the captured image (the color used for marking can be selected):



Figure 7.30: Captured image with displayed edges

7.13.6 Position check

With the **Pattern** and **Contour** methods, the check can also carry out a position check, i.e., it checks whether the position of the found pattern or contour is within a specified area. If this is the case, the result of the position check is "good," otherwise it is "bad." The geometric center point of the taught pattern is regarded as the position.

The overall position result is created by AND combination from the position checks of all checks. This overall position result is output at the **position** sensor output.

With the **Pattern** or **Contour** methods, the following selection element is available to enable the position check on the tabs:



This allows the selection of the following checks:

- **None:** Position check disabled
- **Only X:** Checks whether the horizontal position is within the specified X target value range.
- **Only Y:** Checks whether the vertical position is within the specified Y target value range.
- **X/Y rectangle:** Checks whether the position is within a specified rectangle.
- **X/Y ellipse:** Checks whether the position is within a specified ellipse.

With position check enabled, the target range is displayed blue in the image display:

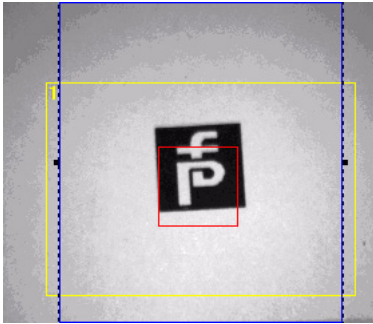

Only X

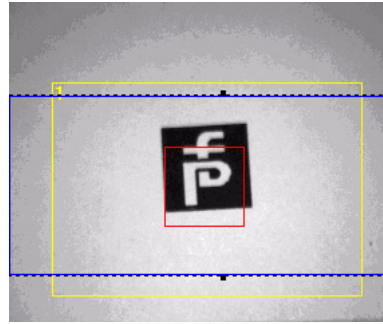

Only Y

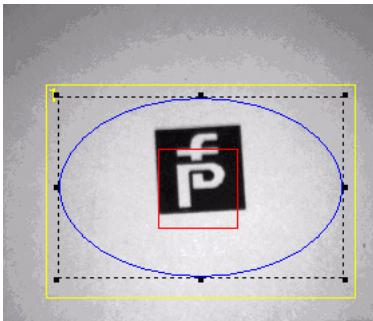

X/Y ellipse

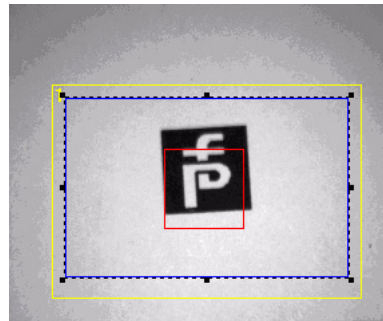

X/Y rectangle

The result of the position check is displayed as an additional LED next to the result bar. The direction of deviation is the direction in which the pattern was found outside the position area:



Position check positive:

Results	●●	18	<div style="width: 100%; height: 10px; background-color: blue;"></div>
Position X	157		
Position Y	116		
Displacement	Center		
Angle	-1.0		

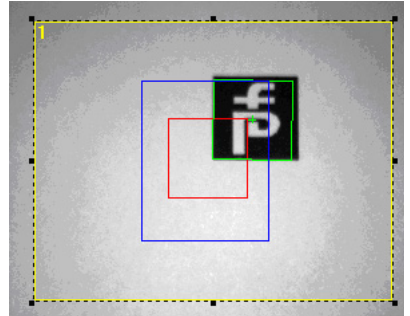

LED green

Pattern within position area

Position check negative:

Results	●●	18	<div style="width: 100%; height: 10px; background-color: blue;"></div>
Position X	208		
Position Y	142		
Displacement	Right		
Angle	-1.0		

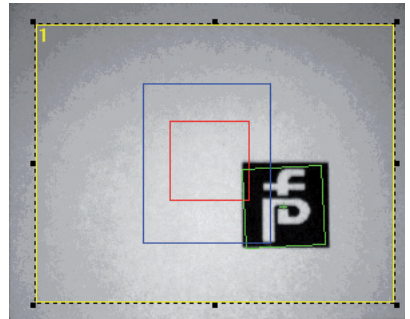

LED red

Pattern to the right outside the position area



7.14 Password manager

During installation, "PF" is set as the password for the administrator level (see chapter 7.2). The password manager is used to change this password.

The password manager can be started by executing the file VOS3-Configpwd.exe in the VOS3-Config program directory (normally c:\programme\VOS3-Config).

Once the password manager opens, a new administrator password can be entered and saved by pressing the "Set" button:



Before the password is saved, the following security prompt appears:



Caution!

After clicking **OK**, the new password becomes active immediately and the previous password will no longer be accepted.

8 Telegrams for communication via serial and network interfaces

Telegrams are used to activate jobs and transmit the results via the interfaces. The telegram definitions are identical for RS 422 and network interfaces, although the "Send bank table" and "Send job" telegrams are only available via the network interface because of the large volumes of data that are transmitted.

The telegrams are all structured according to the following pattern:

Telegram header	Informative data	End byte
-----------------	------------------	----------

The telegram header contains the following:

1st byte:	167 = A7h ('\$')
2nd and 3rd byte:	Telegram identifier, 2 ASCII characters
4th and 5th byte:	Telegram counter (any value between 0 - FF, 2 digits ASCII hexadecimal)
6th to 8th byte:	EXOR checksum over entire telegram (ASCII hexadecimal)
9th to 14th byte:	Telegram length (entire telegram with header, informative data and end byte), 6 digits ASCII decimal

The end byte has the value 223 = DFh ('B').

The telegram counter can be set to any value between 0 and FF, the sensor then returns this value in the telegram response. Sent and received telegrams can be assigned correctly as a result.

The informative data varies depending on the telegram. For every telegram sent to the sensor, a telegram response is sent in reply. The telegram response contains data or an acknowledgment only, depending on the telegram sent. In each instance, the telegram response contains the actuating command and an acknowledgement from the sensor:

S = "Success", command executed successfully

F = "Fail", command execution unsuccessful

The checksum is calculated across all the telegram bytes using an EXCLUSIVE OR.

8.1 Telegrams for sensor

The telegram identifier located in the header in the telegrams sent to the sensor always has the value 1011 = \$B hexadecimal in the higher level 4 bits, whereas the lower level bits identify the telegram. The informative data contains a command in the form of 2 ASCII bytes as well as a 2-digit data value or a converted pfc file if required (for Send job):

Telegram header					Usable data		End byte	
Start	Identifier	Counter	Check	Length	Command	Data	End	Description
'\$'	"BA"	"xx"	"\$xx"	"000017"	"SN"		'B'	"Snap" (trigger image)
'\$'	"BB"	"xx"	"\$xx"	"000019"	"CB"	"0x"	'B'	"Change bank" (change job)
'\$'	"BC"	"xx"	"\$xx"	"000017"	"SB"		'B'	"Get bank table" (LAN only)
'\$'	"BD"	"xx"	"\$xx"	"000019"	"CM"	"0x"	'B'	"Change bank"
'\$'	"BE"	"xx"	"\$xx"	"xxxxxx"	"SJ"	Converted pfc file	'B'	"Send job" (LAN only)

Table 8.1: Telegrams for sensor

Snap

Triggers an image capture with evaluation ("software trigger"). This command is only practical when the sensor is in triggered image capture mode. The sensor initially responds to a Snap command with an AC type telegram and then with an AA type data telegram (see "AC type telegram response" on page 84).

The complete telegram to be sent is structured as follows:

\$BA00\$44000017SNB

Change bank:

Switches the active job to the specified hexadecimal value (data: 00 = Job0 to 0F = Job15). The sensor responds to the command with an AC type telegram.

The individual telegrams appear as follows:

§BB00\$55000019CB00B	Telegram for switching to Job0
§BB00\$54000019CB01B	Telegram for switching to Job1
§BB00\$57000019CB02B	Telegram for switching to Job2
§BB00\$56000019CB03B	Telegram for switching to Job3
§BB00\$51000019CB04B	Telegram for switching to Job4
§BB00\$50000019CB05B	Telegram for switching to Job5
§BB00\$53000019CB06B	Telegram for switching to Job6
§BB00\$52000019CB07B	Telegram for switching to Job7
§BB00\$5D000019CB08B	Telegram for switching to Job8
§BB00\$5C000019CB09B	Telegram for switching to Job9
§BB00\$24000019CB0AB	Telegram for switching to Job10 (=0A Hex)
§BB00\$27000019CB0BB	Telegram for switching to Job11 (=0B Hex)
§BB00\$26000019CB0CB	Telegram for switching to Job12 (=0C Hex)
§BB00\$21000019CB0DB	Telegram for switching to Job13 (=0D Hex)
§BB00\$20000019CB0EB	Telegram for switching to Job14 (=0E Hex)
§BB00\$23000019CB0FB	Telegram for switching to Job15 (=0F Hex)

Get bank table

Authorizes the sensor to transmit the names of all the jobs. The names of all 16 jobs are always sent, even if they are not all used. The unused names are listed at "Job 0" to "Job 15". The corresponding reply from the sensor is an AB type telegram (see "AB type telegram response" on page 85).

Complete telegram:

§BC00\$5E000017GBB

Change mode:

Switches each data telegram generated after a trigger process to ASCII or binary mode:

§BD00\$5C000019CM00B	complete telegram for switching to binary mode
§BD00\$5D000019CM01B	complete telegram for switching to ASCII mode

The sensor responds to the CM command with an AC type telegram.

Send job:

Switches the sensor to Setup mode, loads a pfc file into the active job and then activates Automatic mode again. The pfc file is then transmitted as ASCII data. The pfcConvert.exe program on the VOS302/312 CD is provided to convert a pfc file into a complete SJ command.

The **Get bank table** and **Send job** telegrams (as well as the corresponding telegram responses) are only available via the network interface.

8.2 Telegrams from the sensor

The telegram identifier located in the header in the telegrams sent by the sensor always has the value 1010 = \$A hexadecimal in the higher level 4 bits, whereas the lower level bits identify the telegram.

AC type telegram response

An AC type telegram is sent in reply to the commands SN, CB, CM and SJ. It does not contain any additional data:

Byte	Meaning	Content	Explanation
0	Start byte	'\$'	
1 and 2	Identifier	"AC"	Telegram type
3	Counter	"x"	Counter, ten's position
4	Counter	"x"	Counter, one's position
5 to 7	Check sum	"\$xx"	
8	Length	'0'	Length of telegram, hundred thousand's position
9	Length	'0'	Length of telegram, ten thousand's position
10	Length	'0'	Length of telegram, thousand's position
11	Length	'0'	Length of telegram, hundred's position
12	Length	'0'	Length of telegram, ten's position
13	Length	'0'	Length of telegram, one's position
14	Job number	'0' to 'F'	Active job
15 and 16	Command	'SN'	Triggering command, 2 ASCII bytes
17	Acknowledgement	'F' to 'S'	Acknowledgement, 1 ASCII byte: 'F' = Fault, 'S' = Successful
18 to 20	End identifier	'B', CR, LF	

Table 8.2: AC type telegram response

AB type telegram response

 The VOS302/312 sends the AB type telegram in response to the **GB** command:

Byte	Meaning	Content	Explanation
0	Start byte	'S'	
1 and 2	Identifier	"AB"	Telegram type
3	Counter	"x"	Counter, ten's position
4	Counter	"x"	Counter, one's position
5 to 7	Check sum	"\$xx"	
8	Length	'0'	Length of telegram, hundred thousand's position
9	Length	'0'	Length of telegram, ten thousand's position
10	Length	'0'	Length of telegram, thousand's position
11	Length	'5'	Length of telegram, hundred's position
12	Length	'2'	Length of telegram, ten's position
13	Length	'6'	Length of telegram, one's position
14	Job number	'0' to 'F'	Active job
15 and 16	Command	"GB"	Triggering command, 2 ASCII bytes
17	Acknowledgement	'F' to 'S'	Acknowledgement, 1 ASCII byte: "F" = Fault, "S" = Successful
18 to 49	Name job 0		Name of job 0, 32 ASCII bytes
50 to 81	Name job 1		Name of job 1, 32 ASCII bytes
82 to 113	Name job 2		Name of job 2, 32 ASCII bytes
114 to 145	Name job 3		Name of job 3, 32 ASCII bytes
146 to 177	Name job 4		Name of job 4, 32 ASCII bytes
178 to 209	Name job 5		Name of job 5, 32 ASCII bytes
210 to 241	Name job 6		Name of job 6, 32 ASCII bytes
242 to 273	Name job 7		Name of job 7, 32 ASCII bytes
274 to 305	Name job 8		Name of job 8, 32 ASCII bytes
306 to 337	Name job 9		Name of job 9, 32 ASCII bytes
338 to 369	Name job 10		Name of job 10, 32 ASCII bytes
370 to 401	Name job 11		Name of job 11, 32 ASCII bytes
402 to 433	Name job 12		Name of job 12, 32 ASCII bytes

Byte	Meaning	Content	Explanation
434 to 465	Name job 13		Name of job 13, 32 ASCII bytes
466 to 497	Name job 14		Name of job 14, 32 ASCII bytes
498 to 529	Name job 15		Name of job 15, 32 ASCII bytes
530 to 532	End identifier	'B', CR, LF	

Table 8.3: AC type telegram response

After switching on for the first time, the names of the jobs are initialized for "Job 0" to "Job 15". 32 bytes are transmitted for each name, unused bytes in the names are set to 0.

AA type telegram response (data telegram)

An AA type data telegram is sent by the sensor following each evaluation, irrespective of whether it was triggered by an SN command, a cyclical trigger pulse during non-synchronized operation.

The following values are displayed for position detection:

- Horizontal position in pixels relative to the left image edge (values 0-319)
- Vertical position in pixels relative to the top image edge (values 0-239)
- Rotation angle (for contour method only, 0 is specified for all other methods)
- Sector (for activated position check in sample and contour method only)
- Used method
- Evaluation

If operations are performed without position correction, then 0 is sent for all the data and 'B' for the evaluation.

If a position check is activated during position detection, the sector specification is based on the direction in which the sample or the contour was found starting from the teach-in position (displayed as a hexadecimal value between 0 and B):

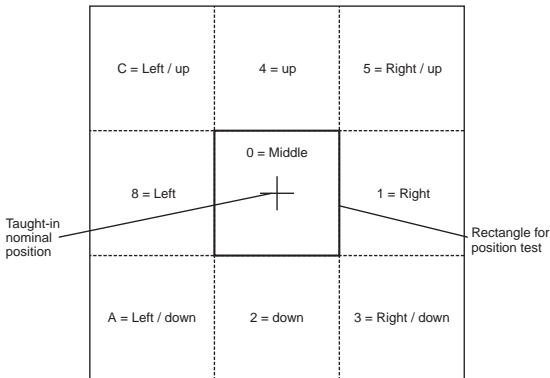

A position check can only be activated for sample and contour position detection methods. If the position check is not activated the sector is set to 0.

The position detection and individual checks are evaluated according to the selected evaluation method:

For gray value, gradient and contrast evaluation methods:

B = check invalid ("Bad")

G = check valid ("Good")

For sample and contour evaluation methods **without** active position check:

B = check invalid ("Bad")

g = check valid ("Good")

For sample and contour evaluation methods with active position check:

B = check invalid

G = check valid and position check "out of range"

g = check valid and position check "in range"

The **values** for the individual checks fall within different ranges depending on the evaluation method used:

0-255 for the gray value and gradient methods

0-20 for contrast, sample and contour

The following values are displayed for each check:

- Evaluation method
- Measured value
- Evaluation

The telegram has a fixed length, i.e., values are sent for all 6 checks, even if fewer checks are active. For unused checks, 0 is sent for the method and measurement value and 'B' for the evaluation.

If operations are performed without position correction, 0 is sent for the position and angle value. Data telegrams can be sent in either binary or ASCII mode. The **Change mode** command determines which mode is active.

AA type telegram in binary mode:

Byte	Meaning	Type	Explanation
0	Start byte	'S'	
1 and 2	Identifier	"AA"	
3	Counter	'0' to 'F'	Counter, ten's position
4	Counter	'0' to 'F'	Counter, one's position
5 to 7	Check sum	"\$xx"	Check sum
8 to 13	Length	'000048'	Length of telegram, (6 ASCII bytes)
14	Job number	'0' to 'F'	Active job
15 and 16	Command	"00"	Triggering command, 2 ASCII bytes (00 = external / independent)
17	Acknowledgement	'F' or 'S'	Acknowledgement, 1 ASCII byte: 'F' = Fault, 'S' = Successful
18	Total result	'G', 'B' or 'g'	ASCII character: 'G' or 'B' or 'g' ('G' = GOOD (checks), 'B' = BAD (checks), 'g' = checks + position good)
19	X position	0 to 127	Horizontal position detection High byte
20	X position	0 to 127	Horizontal position detection Low byte
21	Y position	0 to 127	Vertical position detection High byte
22	Y position	0 to 127	Vertical position detection Low byte
23	Angle	0 to 127	Angle, high byte
24	Angle	0 to 127	Angle, low byte
25	Sector		00 - 0C
26	Position detection	Method	00 = none, 01 = blob, 02 = edge detection, 03 = pattern, 04 = contour
27		Evaluation	ASCII character: 'g' or 'B'
28	Number of checks	01 to 06	
29	Check 1	Evaluation method	0 = gray threshold, 1 = gradient, 2 = contrast, 3 = pattern, 4 = contour
30		Measured value	0 - 255 for method 0+1 or 0 - 20 for method 2, 3, 4
31		Evaluation	'G', 'B', 'g'

Byte	Meaning	Type	Explanation
32	Check 2	Evaluation method	0 = gray threshold, 1 = gradient, 2 = contrast, 3 = pattern, 4 = contour
33		Measured value	0 - 255 for method 0+1 or 0 - 20 for method 2, 3, 4
34		Evaluation	ASCII character: 'G' or 'B' or 'g' (see check 1)
35	Check 3	Evaluation method	0 = gray threshold, 1 = gradient, 2 = contrast, 3 = pattern, 4 = contour
36		Measured value	0 - 255 for method 0+1 or 0 - 20 for method 2, 3, 4
37		Evaluation	ASCII character: 'G' or 'B' or 'g' (see check 1)
38	Check 4	Evaluation method	0 = gray threshold, 1 = gradient, 2 = contrast, 3 = pattern, 4 = contour
39		Measured value	0 - 255 for method 0+1 or 0 - 20 for method 2, 3, 4
40		Evaluation	ASCII character: 'G' or 'B' or 'g' (see check 1)
41	Check 5	Evaluation method	0 = gray threshold, 1 = gradient, 2 = contrast, 3 = pattern, 4 = contour
42		Measured value	0 - 255 for method 0+1 or 0 - 20 for method 2, 3, 4
43		Evaluation	ASCII character: 'G' or 'B' or 'g' (see check 1)
44	Check 6	Evaluation method	0 = gray threshold, 1 = gradient, 2 = contrast, 3 = pattern, 4 = contour
45		Measured value	0 - 255 for method 0+1 or 0 - 20 for method 2, 3, 4
46		Evaluation	ASCII character: 'G' or 'B' or 'g' (see check 1)
47	End identifier	'B'	

Table 8.4: AA type telegram in binary mode

The position values determined during position detection are sent in binary mode in the form of 2 bytes, whereby both the high and low byte can have a maximum value of 127. The MSB is always 0 to ensure that the entire telegram does not contain any bytes set with MSB, except for the start and end identifiers. The value for the positions or the angle is calculated from the high and low byte as follows:

$$\text{Value} = \text{high byte} * 128 + \text{low byte}$$

The gray value 0 ... 255 in the result message is linked to the gray value in VOS3-Config as follows:

$$\text{VOS3-Config value} = 338.7 * (\exp(T / 255) - 1)^2$$

T: Telegram value

exp: nat. exponential function

AA type telegram in ASCII mode:

Byte	Meaning	Content	Explanation
0	Start byte	'S'	
1 and 2	Identifier	"AA"	Telegram type
3	Counter	'0' - 'F'	Counter, ten's position
4	Counter	'0' - 'F'	Counter, one's position
5 to 7	Check sum	"\$xx"	
8 to 13	Length	"000072"	Length of telegram, (6 ASCII bytes)
14	Job number	'0' to 'F'	Active job (ASCII)
15 and 16	Command	"00"	Triggering command, 2 ASCII bytes (00 = external / independent)
17	Acknowledgement	'F' or 'S'	Acknowledgement, 1 ASCII byte: 'F' = Fault, 'S' = Successful
18	Total result	'G', 'B' or 'g'	ASCII character: 'G' or 'B' or 'g' 'G' = GOOD (checks), 'B' = BAD (checks), 'g' = checks + position good
19 to 24	X position	"-99999" - "+99999"	Horizontal position detection 6 ASCII bytes
25 to 30	Y position	"-99999" - "+99999"	Vertical position detection 6 ASCII bytes
31 to 36	Angle	"-99999" - "+99999"	Position detection angle (5 positions with prefix)
37	Sector	'0' - 'C'	\$00 - \$0C
38	Position detection	'0' - '4'	Method: 0 = none, 1 = blob, 2 = edge detection, 3 = pattern, 4 = contour
39		'g' - 'B'	Evaluation: 'g' = GOOD, 'B' = BAD
40	Number of checks	'1' - '6'	
41	Check 1	'0' - '4'	0 = gray threshold, 1 = gradient, 2 = contrast, 3 = pattern, 4 = contour

2012.10.20.10-04

Byte	Meaning	Content	Explanation
42 to 44		'00' - '255'	0 - 255 for method 0+1 or 0 - 20 for method 2, 3, 4
45		'G', 'B', 'g'	Evaluation: 'G' or 'B' or 'g'
46	Check 2	Evaluation method	0 = gray threshold, 1 = gradient, 2 = contrast, 3 = pattern, 4 = contour
47 to 49		Measured value	0 - 255 for method 0+1 or 0 - 20 for method 2, 3, 4
50		Evaluation	ASCII character: 'G' or 'B' or 'g' (see check 1)
51	Check 3	Evaluation method	0 = gray threshold, 1 = gradient, 2 = contrast, 3 = pattern, 4 = contour
52 to 54		Measured value	0 - 255 for method 0+1 or 0 - 20 for method 2, 3, 4
55		Evaluation	ASCII character: 'G' or 'B' or 'g' (see check 1)
56	Check 4	Evaluation method	0 = gray threshold, 1 = gradient, 2 = contrast, 3 = pattern, 4 = contour
57 to 59		Measured value	0 - 255 for method 0+1 or 0 - 20 for method 2, 3, 4
60		Evaluation	ASCII character: 'G' or 'B' or 'g' (see check 1)
61	Check 5	Evaluation method	0 = gray threshold, 1 = gradient, 2 = contrast, 3 = pattern, 4 = contour
62 to 64		Measured value	0 - 255 for method 0+1 or 0 - 20 for method 2, 3, 4
65		Evaluation	ASCII character: 'G' or 'B' or 'g' (see check 1)
66	Check 6	Evaluation method	0 = gray threshold, 1 = gradient, 2 = contrast, 3 = pattern, 4 = contour
67 to 69		Measured value	0 - 255 for method 0+1 or 0 - 20 for method 2, 3, 4
70		Evaluation	ASCII character: 'G' or 'B' or 'g' (see check 1)
71 to 73	End identifier	'B', CR, LF	

Table 8.5: AA type telegram in ASCII mode

Example 1:

VOS312 with triggered image capture in binary mode after transmission of an SN command:

```

00000000 A7 41 43 30 30 24 32 41 30 30 30 30 31 39 32 53 §AC00$2A 0000192S
00000010 4E 53 DF 0D 0A A7 41 41 39 30 24 38 46 30 30 30 NSD..$AA 90$8F000
00000020 30 34 38 32 30 30 53 67 00 45 01 48 00 00 00 02 048200Sg .E.H....
00000030 67 02 01 8D 47 03 14 67 00 00 42 00 00 42 00 00 g..#G..g ..B..B..
00000040 42 00 00 42 DF B..B0
    
```

A telegram response is sent to the SN command

Data telegram AA

A telegram response is sent to the SN command first of all:

Offset (hex)	Hexadecimal	ASCII	Meaning
00	A7	§	Start byte
01	41 43	AC	Telegram type
03	30 30	00	Counter
05	24 32 41	\$2A	Check sum
08	30 30 30 30 31 39	000019	Length
0E	32	2	Active job
0F	53 4E	SN	Triggering command
11	53	S	Acknowledgement (S = successful)
12	DF 0D 0A	β<CR><LF>	End identifier

Finally, the sensor sends the data telegram (starting at 015 hex. in above-mentioned hex dump):

AA telegram:

Offset (hex)	Hexadecimal	ASCII	Meaning
00	A7	§	Start byte
01	41 41	AA	Telegram type
03	39 30	90	Counter
05	24 38 46	\$8F	Check sum
08	30 30 30 30 34 38	000048	Length
0E	32	00	Active job
0F	30 30	SN	Triggering command
11	53	S	Acknowledgement (S = successful)
12	67	g	Total result
13	00 45		X position (45 hex = 69 decimal)
15	01 48		Y position (200, see explanation)
17	00 00		Angle (0°)
19	00		Sector
1A	02	02	Position detection: Method (2 = edge detection)

2012.10.20/10-04

Offset (hex)	Hexadecimal	ASCII	Meaning
1B	67	g	Position detection result (g = good')
1C	02		Number of checks
1D	01		Check 1: Method (3 = pattern)
1E	8D		Check 1: Measured value (8D hex. = 141 dec.)
1F	47	G	Check 1: Result (G = 'good')
20	03		Check 2: Method (3 = pattern)
21	14		Check 2: Measured value (14 hex. = 20 dec.)
22	67	g	Check 2: Result (G = 'good')
23	00		Check 3: Method
24	00		Check 3: Measured value
25	42	B	Check 3: Result
26	00		Check 4: Method
27	00		Check 4: Measured value
28	42	B	Check 4: Result
29	00		Check 5: Method
2A	00		Check 5: Measured value
2B	42	B	Check 4: Measured value
2C	00		Check 6: Method
2D	00		Check 6: Measured value
2E	42	B	Check 6: Result
2F	DF	ß	End identifier

Table 8.6: AA telegram

The positions are interpreted as follows:

X position: $00 \text{ Hex} * 128 + 45\text{Hex} = 0 + 69 = 69$

Y position: $01 \text{ Hex} * 128 + 48\text{Hex} = 128 + 72 = 200$

9 Maintenance and repair

9.1 Maintenance

The cable and power supply are maintenance-free. To get the best possible performance out of your device, keep the optical unit on the reader clean and always clean whenever necessary.

Observe the following instructions when cleaning:

- Do not touch the optical unit with your fingers.
- Do not immerse the stationary reader in water. Do not spray the device with water or other fluids.
- Do not use scouring agent to clean the surface of the device.
- Use a cotton or paper cloth moistened with water or isopropyl alcohol (not soaked).
- Remove any residual alcohol using a cotton or paper cloth moistened with distilled water (not soaked).
- Wipe the surface of the device dry using a lint-free cloth.

9.2 Repair

The devices may not be repaired, changed or manipulated. If there is a defect, the product must always be replaced with an original part.

10 Troubleshooting

10.1 What to do in the event of an error

Before requesting a service call, please check that the following actions have been taken:

- Test the equipment according to the following checklists,
- Telephone assistance from the Service Center in order to isolate the problem.

Checklist

Error	Cause	Remedy
"PWR" LED not lit up	The power supply is switched off.	Check whether there is a reason why it is switched off (installation or maintenance work etc.). Switch the power supply on if appropriate.
"PWR" LED not lit up	The M12 socket is not connected to the connector on the sensor.	Connect the 8-pin M12 socket to the sensor and tighten the cap nut by hand.
"PWR" LED not lit up	Wiring fault in the splitter or control cabinet.	Check the wiring carefully and repair any wiring faults.
"PWR" LED not lit up	Supply cable to the sensor is damaged.	Replace the damaged cable.
No connection to the device	Network cable not connected.	Connect the network cable.
No connection to the device	Wrong network cable used.	Direct connection between PC and device: Use a crossover network cable. Connection via an existing network: Use a twisted-pair network cable.

- If none of the above remedies correct the problem, please contact the Service Center. Please have the fault patterns and version numbers of the sensor. The version number can be found at the bottom left of the operator interface.

11 Appendix

11.1 Dimensions

11.1.1 Sensor VOS302/VOS312

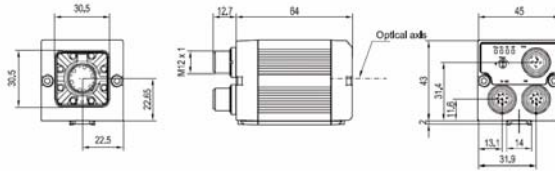

11.1.2 OMH-VOS300-K01

The dovetail terminal block is included in the delivery.

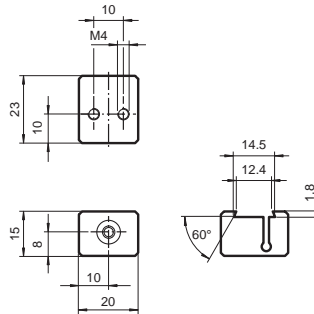

11.1.3 OMH-VOS300-01

The mounting bracket is **not** included with the delivery.

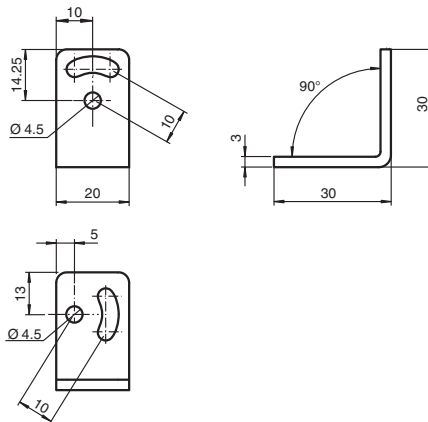

2012.10 2010-04

FACTORY AUTOMATION – SENSING YOUR NEEDS



Pepperl+Fuchs sets the standard in quality and innovative technology for the world of automation. Our expertise, dedication, and heritage of innovation have driven us to develop the largest and most versatile line of industrial sensor technologies and interface components in the world. With our global presence, reliable service, and flexible production facilities, Pepperl+Fuchs delivers complete solutions for your automation requirements – wherever you need us.

Contact

Pepperl+Fuchs GmbH
Lilienthalstraße 200
68307 Mannheim · Germany
Tel. +49 621 776-4411 · Fax +49 621 776-27-4411
E-mail: fa-info@pepperl-fuchs.com

Worldwide Headquarters

Pepperl+Fuchs GmbH · Mannheim · Germany
E-mail: fa-info@pepperl-fuchs.com

USA Headquarters

Pepperl+Fuchs Inc. · Twinsburg, OH · USA
E-mail: fa-info@us.pepperl-fuchs.com

Asia Pacific Headquarters

Pepperl+Fuchs Pte Ltd · Singapore
Company Registration No. 199003130E
E-mail: fa-info@sg.pepperl-fuchs.com

www.pepperl-fuchs.com

Subject to reasonable modifications due to technical advances
Copyright Pepperl+Fuchs • Printed in Germany

 **PEPPERL+FUCHS**
SENSING YOUR NEEDS

201210 / TDOCT1567A_ENG

04/2010