



MANUAL

VBA-4E1A-KE3-ZEJ/SR
AS-Interface Safety Output Relay





With regard to the supply of products, the current issue of the following document is applicable: The General Terms of Delivery for Products and Services of the Electrical Industry, published by the Central Association of the Electrical Industry (Zentralverband Elektrotechnik und Elektroindustrie (ZVEI) e.V.) in its most recent version as well as the supplementary clause: "Expanded reservation of proprietorship"

Table of Contents

1	Symbol Catalog	3
1.1	Abbreviations	3
2	General Remarks.....	4
2.1	Product information	4
2.2	Function of this manual	4
2.3	Target group	4
2.4	AS-i specification 3.0	4
3	Safety	5
3.1	Experienced staff	5
3.2	Application area of the device	5
3.3	Correct use	5
3.4	Disposal	6
4	Product Description.....	7
4.1	AS-i Safety at Work	7
4.1.1	Special characteristics of the AS-i Safety Output Relay	7
4.2	Technical Data	8
4.3	Safety relevant data	9
4.4	Electronic connection.....	10
4.5	Operating interface	11
4.6	Indicators	11
5	Maintenance	12
5.1	Controlling safe shutdowns	12
6	Address Assignment	13
6.1	Programming of the safety relevant AS-i address	13
6.2	Programming of the non-safety relevant AS-i address	13
7	Safety Requirements	14
8	Installation Instructions.....	15
8.1	VBA-4E1A-KE3-ZEJ/SR.....	15

Issue date: 24.11.2008

8.2	Dimensions.....	15
8.3	Front view and connections	16
8.3.1	Connecting a safety contactor.....	17
8.4	Programming the safety relevant AS-i address (PRG).....	18
8.4.1	Address assignment.....	19
8.4.2	Checking safety relevant address 15.....	20
8.5	Programming of the non-safety relevant AS-i address (RUN).....	21
8.5.1	Address assignment.....	22
8.5.2	LEDs.....	23
8.6	Montage	24

Issue date: 24.11.2008

1. Symbol Catalog



Information!

This symbol indicates important information.



Attention!

This symbol warns of a potential failure. Non-compliance may lead to interruptions of the device, the connected peripheral systems, or plant, potentially leading to total malfunctioning.



Warning!

This symbol warns of an imminent danger. Non-compliance may lead to personal injuries that could be fatal or result in material damages and destruction.

1.1 Abbreviations

AS-i	AS-interface (actuator sensor interface)
AOPD	Active opto-electronic protective device
CRC	Cyclic redundancy check
I/O	Input/output
EDM	External device monitoring
EMC	Electromagnetic compliance
ESD	Electrostatic discharge
PELV	Protective extra-low voltage
PFD	Probability of failure on demand
PLC	Programmable logic control
SaW	Safety at Work, safety technic

2. General Remarks

Please read this chapter carefully before working with the documentation and the AS-i Safety Output Relay with four standard inputs.

2.1 Product information

This user manual is valid for the following Pepperl+Fuchs GmbH devices:

AS-i Safety Output Relay with four standard inputs	VBA-4E1A-KE3-ZEJ/SR
--	----------------------------

2.2 Function of this manual

This manual instructs for the safe assembly, electrical installation, addressing, start-up as well as for the operation and for the maintenance of AS-i Safety Output Relay.

This manual does *not* provide instructions for operating machines, on which this module is built in. Please view the appropriate machine manual for corresponding information.

2.3 Target group

This manual is intended for designers, developers and operators of systems that will be safeguarded by one or more AS-i Safety Output Relays. The manual is also targeted to people integrating AS-i Safety Output Relays into machinery, performing the initial start-up, or maintaining them.

2.4 AS-i specification 3.0

The AS-i Safety Output Relay with four standard inputs is designed according to the new AS-i specification 3.0.

Earlier specifications (2.1 and 2.0) continue to be fully supported.

3. Safety

This chapter contains user safety information.



Warning!

Please read this chapter carefully before using the AS-i Safety Output Relay in combination with other machine safeguarding components on protected machinery.

3.1 Experienced staff

The AS-i Safety Output Relay must only be installed, operated, and maintained by qualified staff.

Qualified is a person who

- has a suitable technical education
- has been instructed in operating the machinery and has been informed about the valid safety guidelines by the machinery operator
- has access to the user manual.

3.2 Application area of the device

The VBA-4E1A-KE3-ZEJ/SR is a decentralized output-module that safely controls actuators on the AS-i Safety at Work (SaW) safety bus system.

In this set-up, a Safety Monitor or a Gateway with integrated Safety Monitor, respectively, controls the VBA-4E1A-KE3-ZEJ/SR.

A special characteristic of this module is its two different kinds of AS-i addresses:

- Safe AS-i address
VBA-4E1A-KE3-ZEJ/SR listens to the communication on the safe address and switches based on these data.
- Non-safety relevant AS-i address
The non-safety relevant AS-i address is used for diagnostic purposes and for switching under PLC control.

All SaW output modules with the same safe AS-I address switch at the same time.

The VBA-4E1A-KE3-ZEJ/SR is certified according to EN 62 061, SIL 3, and EN 13 849, performance level e.

3.3 Correct use

The AS-i Safety Output Relay must only be used as defined in chap. Application area of the device. The AS-i Safety Output Relay must only be used on the system, at which it was installed in accordance with this manual by adept personnel.



Information!

If used in a way differing from this description or if the device has been changed in any way – even during installation – any warranty claims with respect to Pepperl+Fuchs GmbH are invalid.

Issue date: 24.11.2008

3.4 Disposal



Information!

Electronic waste is hazardous waste. Please comply with all local ordinances when disposing this product!

The device does not contain batteries that need to be removed before disposing it.

4. Product Description

This chapter is intended to inform the reader about the special characteristics of the AS-i Safety Output Relay with four standard inputs. It describes the design and the functionality of the devices.



Warning!

This chapter must be read before installation and operation of the device in conjunction with other safety components on protected machinery.

4.1 AS-i Safety at Work

AS-i Safety at Work combines safe and non-safe data on a bus system. The classification AS-i Safety at Work identifies the safe data transfer that enables the integration of safety procedures in an AS-i network.

The components of AS-i Safety at Work conform to EN 50295 and are compatible with all other AS-i components. Therefore, existing AS-i applications can easily be extended with safety-relevant functions.

AS-i Safety at Work always requires a Safety Monitor (as a stand-alone device or integrated into a Gateway), that evaluates the safe signals on the bus, and a safe AS-Interface bus connection, that enables the transfer of safe signals from safety-relevant components (AS-i SaW input).

Additionally, decentralized safe AS-i SaW outputs can be added. Controlled by the Safety Monitor these outputs can be used to safely switch off safe actuators.

Several Safety Monitors and safe input and output slaves can be used on an AS-i system. At the same time, the Safety Monitors can be parameterized and, thus, be checked through AS-i and the configuration software.



Information!

By utilizing AS-i Safety at Work safety requirements up to category 4 according to EN 954-1 and additionally performance level e according to EN 13 849 as well as SIL 3 according to EN 62 061 can be satisfied.

In order to satisfy the requirements of these safety categories, all peripheral components, for instance the Safety Monitors, all safe bus connections, and all connected sensors must satisfy these standards.

4.1.1 Special characteristics of the AS-i Safety Output Relay

- Two redundant, force-guided relays
- Two parallel, galvanically isolated contact sets
- 4 standard inputs
- External sensors supplied from AS-i
- Programming jack
- Operating mode selector switch

4.2 Technical Data

Inputs	3 standard inputs + 1 EDM
Outputs	1 relay 3 A, 24 V, DC-13 or 3 A, 230 V, AC-15 respectively
AS-i profile	S.7.A.E
ID1 Code	5 _{hex} (default), user changeable
External device monitoring (EDM)	Supplied from AS-i, about 24 V, about 10 mA
Displays	
3 LEDs yellow (I 1, I 2, I 3)	Status input I1, I2, I3
1 LED yellow (1.Y1)	Status EDM input 1.Y1
LED green (PWR)	AS-i power supply
LED red (FAULT)	AS-i error LED
LED yellow (OUT)	See table for flashing LED pattern "Device colors"
LED red (ALARM)	PLC signals alarm
Operational current	< 200 mA
Supply power for sensors	90 mA
Operational current	AS-i (30 V _{DC})
Over-voltage category	3 for operating voltage 300 V _{AC} acc. to VDE 0110 part 1
Voltage isolation	≥ 6 kV
Utilized standards	EN 954-1 cat. 4; IEC 61 508 SIL 3 EN IEC 62061; EN 13849/PLe
Housing	DIN rail mountable housing
Ambient operating temperature	0°C ... +55 °C
Storage temperature	-25°C ... +85 °C
Dimensions (length/ width/ height in mm)	114 / 22,5 / 99
Protection category according to DIN 60 529	Housing IP20 Only for the use in an electrical enclosure/cabinet with minimum protection category IP54

Device Colors

Value	Color	Description	State change	LED "Out"
0	green	Output on		on
1	green flashing	-		-
2	yellow	Error lock	Auxiliary signal 2	1 Hz
3	yellow flashing	-		-
4	red	Output off		off
5	red flashing	Waiting for error unlock signal	Auxiliary signal 1	8 Hz
6	gray	Internal error, for instance "fatal error"	Only through turning power "on" on the device	all LEDs are flashing
7	green/yellow	Output released but not turned on	Switched "on" by setting O1	off

4.3 Safety relevant data

Identification data	Value	Standard
Safety category	4	EN 954-1
Safety category	4	EN ISO 13849-1
Performance level (PL)	e	
Safety integrated level (SIL)	3	IEC 61508
Usage time (TM) in years	20	EN ISO 13849-1
Maximum operating time in month	12	IEC 61508
PFD ¹	$2 \cdot 10^{-5}$	IEC 61508 EN 62061
PFH _D ¹ (Probability of a dangerous failure per hour)	$3,3 \cdot 10^{-9}$	IEC 61508 EN 62061
Max. system reaction time in milliseconds	50	IEC 61508

1.) The PFD and PFH D values stated here are related to the maximum operating time of 12 month and a maximum usage time of 20 years according to EN ISO 13849-1.
The relay's maximum switch time (including the occurrence of errors) is 50 ms starting at the time the code sequence is present until the switch-off of the relay. Additionally, the response time of the monitor and the inputs must be included.

4.4 Electronic connection

Terminal settings	Description
I1, I2, I3	Inputs I1, I2 and I3
1.13, 1.14	Output connection set 1
1.23, 1.24	Output connection set 2
I-, I+	Supply voltage for inputs
1.Y1	EDM (External Device Monitoring)
AS-i+, AS-i-	Connection to AS-i bus

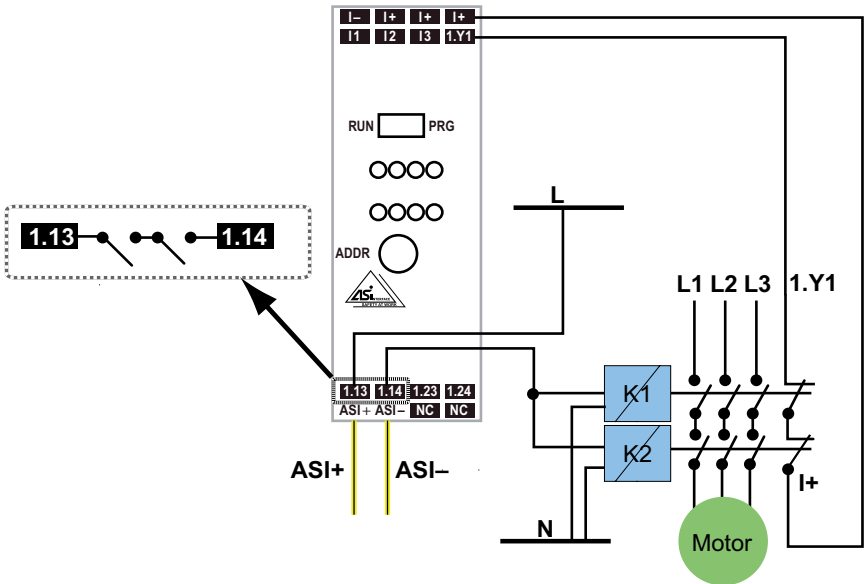

4.5 Operating interface

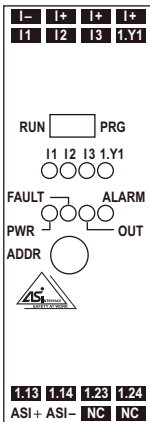

Switch to select the operational mode:

PRG Safety relevant AS-i address can be programmed
 Secure operation not possible.

RUN Secure operation possible, non-safety relevant AS-i address can be programmed.

Addressing jack (ADDR)

4.6 Indicators

Indicators		
Display		Meaning
PWR	off	No supply power
	green 1 Hz flashing	Operational power on, safety relevant AS-i address and/or AS-i AB address is "0"
	green (on)	Supply power on
Fault	off	AS-i communication OK
	red (on)	No data exchange with the AB slave
Out	off	Output Relay switched off
	green 1 Hz flashing	Error lock state, waiting for start signal, after transmission of start signal Output Relay switches on
	green 8 Hz flashing	The device is in an un-lockable error state. The device resumes regular operation after the Monitor sent the signal "error unlock".
	green (on)	Output Relay switched on
Alarm	off	AS-i output bit A0 not set
	red (on)	AS-i output bit A0 set
I1, I2, I3, 1.Y1	off	Corresponding input is not on
	yellow cyclic flashing	Switch set to PRG
	yellow (on)	Corresponding input is on

Issue date: 24.11.2008

5. Maintenance

5.1 Controlling safe shutdowns

The plant safety engineer is responsible for verifying that the AS-i Safety Output Relay with four standard inputs works correctly as part of the safety system.

At least once a year it is necessary to verify the safe shutdown by initiating associated safety-related sensors or switches:



Attention!

Press each safety-related AS-i slave and watch the reaction of the output circuits of the AS-i Safety Monitor.



Attention!

Check the maximum activated time and the total operating time. These values depend on the PFD value chosen for the total failure probability. Please refer to the information in chap. Safety relevant data.

After reaching the projected maximum operating time (three, six, or twelve months) the entire safety system must be checked for proper operation.

After reaching the projected total usage time (20 years) the device must be checked by the manufacturer concerning its proper operation.

6. Address Assignment

The device offers two different types of AS-i addresses:

The safety relevant (single) AS-i address is the target address for the device through which it receives the signal for the safe release of the output. This address is not used for communication; the device only uses it to listen to ongoing communications.

This address can only be programmed if the switch is set to PRG.

The device uses the non-safety relevant (A/B) AS-i address to communicate with the master in order to exchange diagnostics data (I1 ...I3, 1.Y1) and control signals (Alarm LED).

This address can only be programmed if the switch is set to RUN.

6.1 Programming of the safety relevant AS-i address

1. Set device switch to PRG.
2. Set desired address by using the hand-held addressing device or AS-i Master.
3. Check programmed address by using the hand-held addressing device or AS-i Master.
4. Check slave's ID code by using the hand-held addressing device or AS-i Master. The code should be set to "F".
5. Check slave's ID1 code by using the hand-held addressing device or AS-i Master. Code should be the same as the tens-digit of the address.
6. Check slave's ID2 code by using the hand-held addressing device or AS-i Master. The code should be the same as the ones-digit of the address.
7. Check slave's IO code by using the hand-held addressing device or AS-i Master. The code should be "7".
8. If the settings in steps 3 to 7 were correct continue with step 9. Otherwise repeat, starting with step 1.
9. Set the switch on the device to RUN.

Warning!



The correct safety function of the device must be verified once installed within the protected machinery!

6.2 Programming of the non-safety relevant AS-i address

This address can be programmed by using the hand-held addressing device or AS-i Master when the switch is set to RUN.

7. Safety Requirements

- The device uses two redundant, force-guided relays.
- The module recognizes if one of the relays does not switch (for instance if the contacts are welded).
- The contact sets 1.13/1.23 and 1.14/1.24 use the same relay; they do not operate independently.
- The contacts 1.13, 1.23, 1.14, 1.24 are potential-free. A cross-short check is not available.
- If the device is set up to control two independent safety contactors, connected in series, the connection between the safety contactors and the device must never be subjected to another potential as this could result in the inadvertent activation of the safety contactors.
- Input 1.Y1, just like inputs I1... I3, is a standard AS-i input.

8. Installation Instructions

8.1 VBA-4E1A-KE3-ZEJ/SR

AS-i-Safety-Relaisausgangsmodul
AS-i Safety Relay Output Module
Module avec sorties relais de sécurité AS-i
Modulo di uscita relè di sicurezza AS-i
Módulo de salida de relé AS-i Safety



Dokumentationen: "AS-i Safety-Relaisausgangsmodul mit konventionellen 4E" + "ASIMON Konfigurationssoftware für Windows"

Documentations: "AS-i Safety Relais Output Module with 4 standard inputs" + "ASIMON Configuration Software for Windows"

Documentations: "Module avec sorties relais de sécurité AS-i avec 4E standard" + "Logiciel de configuration ASIMON pour Windows"

Documentazioni: "Modulo di uscite relè di sicurezza AS-i con 4 ingressi standard" + "Software di configurazione ASIMON per Windows"

Documentación: "Módulo de salida de relé AS-i Safety con 4E convencional" + "Software de configuración ASIMON para Windows"

8.2 Dimensions

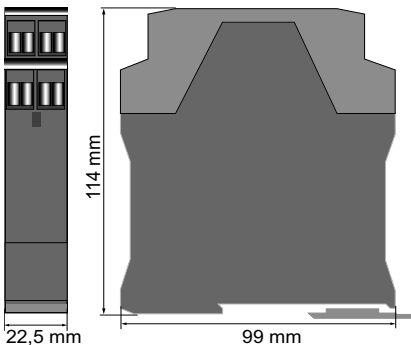

Issue date: 24.11.2008

8.3 Front view and connections

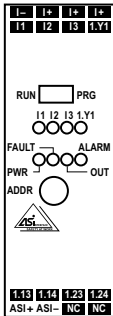

PRG

sicherheitsrelevante AS-i-Adresse kann programmiert werden. Kein Schutzbetrieb möglich // Programming of safety relevant AS-i address enabled. Protective mode disabled // mode de protection non possible. Adresse AS-i relative à la sécurité peut être configurée // modo di protezione non possibile. Indirizzo AS-i relativo alla sicurezza può essere configurato // la dirección AS-i relevante para la seguridad se puede programar. no es posible modo operativo de protección

RUN

Schutzbetrieb möglich, nicht-sicherheitsgerichtete AS-i-Adresse kann programmiert werden // Protective mode enabled. Programming of non-safety relevant AS-i address enabled // mode de protection possible. Adresse AS-i non relative à la sécurité peut être configurée // modo di protezione possibile. Indirizzo AS-i non relativo alla sicurezza può essere configurato // Modo operativo de protección posible, la dirección AS-i no direccionada a la seguridad se puede programar

ADDR

Adressierbuchse // addressing jack // prise d'adressage // presa di indirizzamento // socket de direccionamiento

I1, I2, I3

Eingänge E1, E2 und E3 // Inputs I1, I2 and I3 // entrées E1, E2 et E3 // ingressi I1, I2 e I3 // entrada E1, E2 y E3

1.13, 1.14

Ausgangskontaktsatz 1 // Output contact set 1 // plots de contacts de sortie 1 // set di contatti di uscita 1 // Juego de contacto de salida 1

1.23, 1.24

Ausgangskontaktsatz 2 // Output contact set 2 // plots de contacts de sortie 2 // set di contatti di uscita 2 // Juego de contacto de salida 2

I-, I+

Versorgungsspannung für Eingänge // voltage supply for inputs // tension d'alimentation pour les entrées // tensione di alimentazione per gli ingressi // Tensión de alimentación para entradas

1.Y1

EDM (Eingang Rückführkreis) // EDM (input of external device monitoring circuit) // EDM (entrée circuit feedback) // EDM (ingresso circuito feedback // EDM (entrada circuito de retorno)

ASI+, ASI-

Anschluss AS-i-Bus // AS-i connection // raccordement bus AS-i // collegamento bus AS-i // conexión circuito AS-i

8.3.1 Connecting a safety contactor

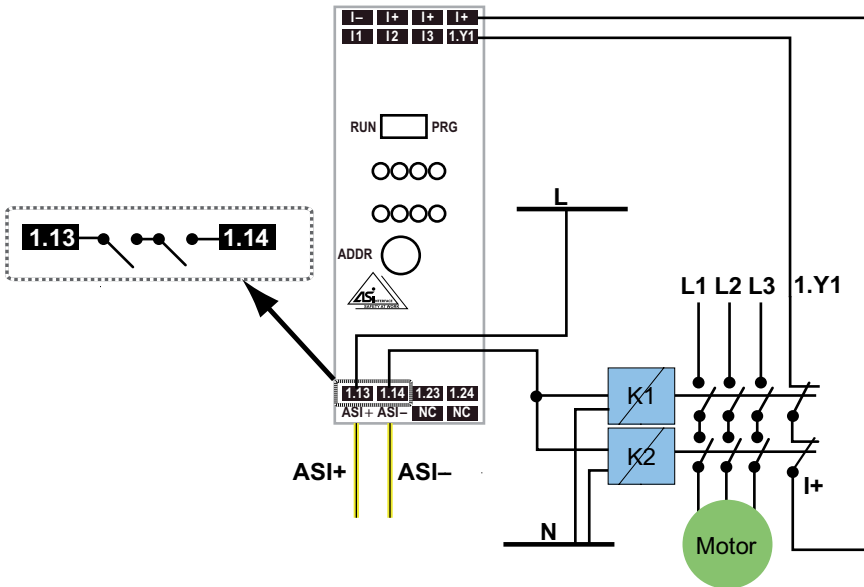

Note

Adressierung ist auch mit Handadressiergeräten möglich // In addition, a hand-held addressing device can be used to program the address // L'adressage est possible également avec un dispositif d'adressage manuel // L'indirizzamento è anche possibile con un dispositivo di programmazione manuale // El asignamiento de dirección es también posible con el dispositivo de mano.

Issue date: 24.11.2008

8.4 Programming the safety relevant AS-i address (PRG)

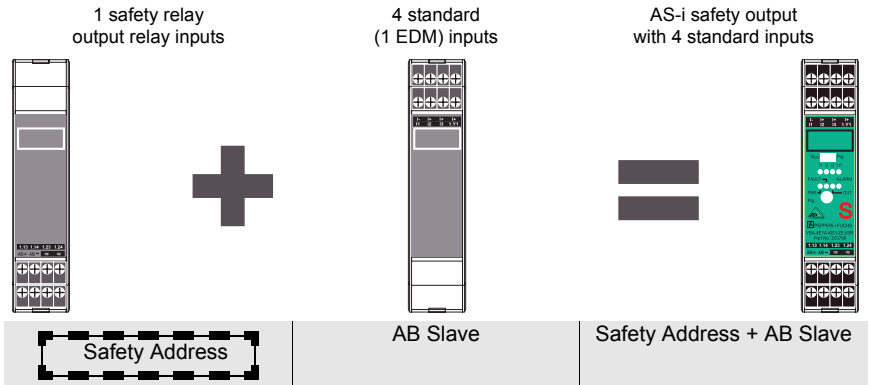

[1]

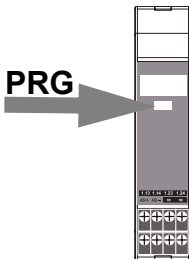

[2]

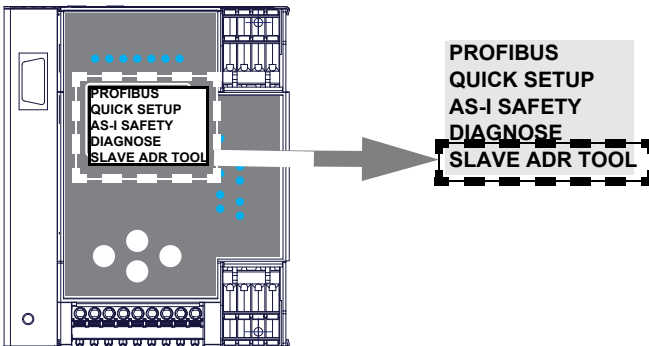

8.4.1 Address assignment

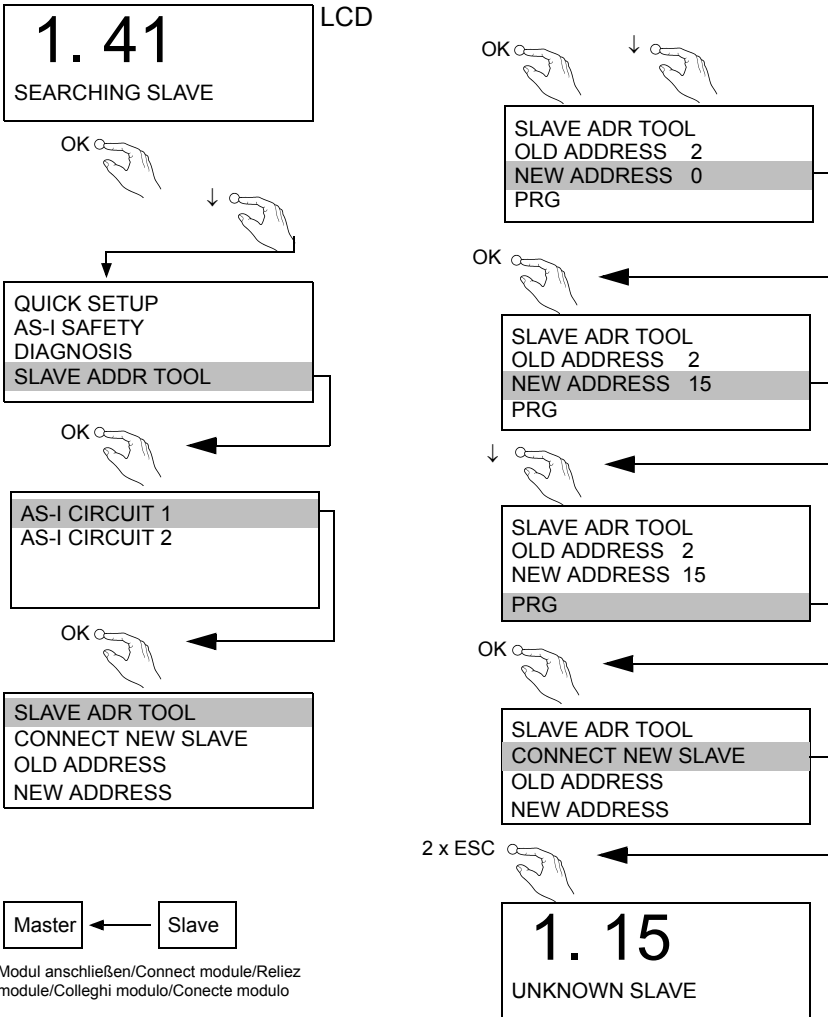

Modul anschließen/Connect module/Reliez module/Collegli modulo/Conecte modulo

Issue date: 24.11.2008

8.4.2 Checking safety relevant address 15

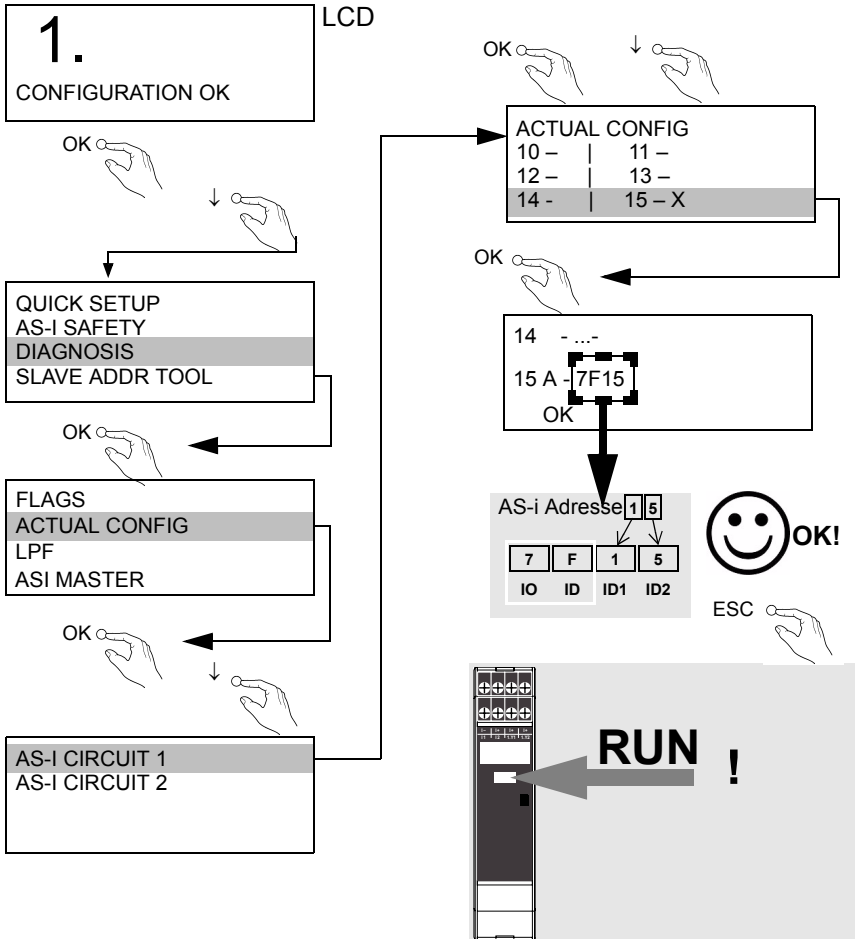

Die korrekte Sicherheitsfunktion des Gerätes muss unbedingt in der Anlage überprüft werden! // The correct safety function of the device must be verified once installed within the protected machinery! // Il faut impérativement contrôler le bon fonctionnement de la fonction de sécurité dans l'installation! // La funzione di sicurezza dell'apparecchio deve imperativamente essere controllata nell'impianto! // La función correcta de seguridad del aparato deberá comprobarse sin falta en el equipo!

8.5 Programming of the non-safety relevant AS-i address (RUN)

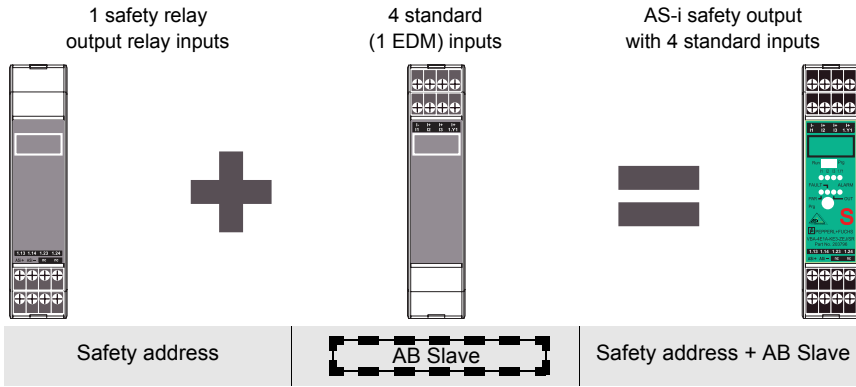

[1]

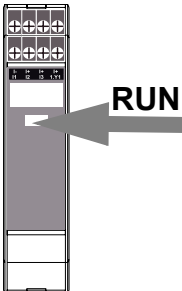

[2]

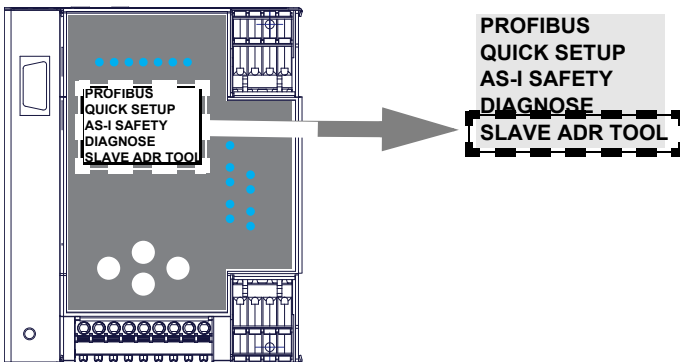



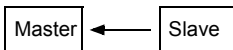
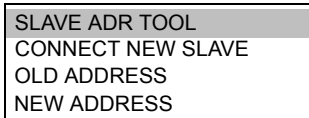
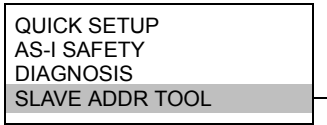
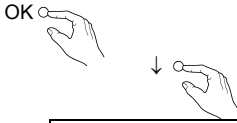



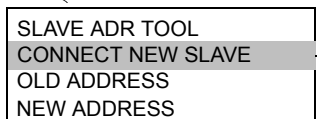
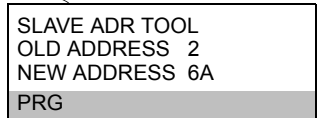
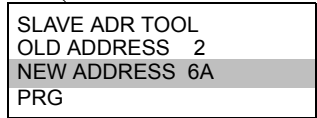
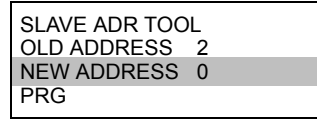







8.5.1 Address assignment



Modul anschließen/Connect module/Reliez module/Colleghi modulo/Conecte modulo



8.5.2 LEDs

LEDs	Colors	Status	Signal // Description
PWR	grün/ green/ verte/ verde/ verde		keine Betriebsspannung // No supply power // pas de tension de fonctionnement // nessuna tensione di funzionamento // No hay tensión de servicio
		 1 Hz	Betriebspannung vorhanden, sicherheitsrelevante Adresse und/oder AS-i-AB-Adresse ist „0“ // Supply power is on, safety-relevant address and/or AS-i AB address is “0” // tensione de fonctionnement présente, adresse relative à la sécurité et/ou adresse AB AS-i est de “0” // tensione di funzionamento presente, indirizzo relativo alla sicurezza e/ o indirizzo AB AS-i è “0” // Hay tensión de servicio, la dirección relevante para la seguridad y/o la dirección AS-i-AB es “0”
			Betriebspannung vorhanden // Supply power on // tension de fonctionnement présente // / tensione di funzionamento presente // Hay tensión de servicio
FAULT	rot/red/ rouge/ rosso/ rojo		AS-i-Kommunikation OK // AS-i communication OK // communication AS-i OK // comunicazione AS-i OK // Comunicación AS-i OK
			kein Datenaustausch mit dem AB-Slave // no data exchange with the AB slave // pas d'échange de données avec l'esclave AB // nessuno scambio dati con lo slave AB // no hay intercambio de datos con el esclavo AB
OUT	gelb/yel- low/ jaune/ giallo/ amarillo		Ausgangsrelais ausgeschaltet // Output relay switched off // relais de sortie éteint // relè di uscita spento // Relé de salida desconectado
		 1 Hz	Wiederanlaufsperrung, wartet auf Startsignal, nach Startsignal schalten die Ausgangsrelais ein // Error lock state, waiting for start signal, after transmission of start signal Output Relay switches on // Blocage redémarrage actif, attend le signal Start, après le signal Start le relais de sortie est commuté // Blocco riavviamento attivo, aspetta il segnale Start, i relè di uscita vengono commutati dopo il segnale start // Bloqueo de reinicio, espera a señal de inicio, después de la señal de inicio el relé de salida se conecta
		 8 Hz	Das Gerät ist im entriegelbaren Fehlerzustand. Wenn der Monitor das Signal "Fehlerentriegelung" sendet, arbeitet das Gerät wieder normal // The device is in an un-lockable error state. The device resumes regular operation after the Monitor sent the signal "error unlock". // L'appareil se trouve dans un état d'erreurs déverrouillable. Lorsque le moniteur envoie le signal "déverrouillage des erreurs", l'appareil fonctionne de nouveau normalement. // L'apparecchio è in stato di errore sbloccabile. Quando il motore invia il segnale "sblocco di errori", l'apparecchio funziona di nuovo normalmente. // El aparato está en estado de error desbloqueable. Si el monitor envía la señal "Desbloqueo de error", el aparato vuelve a funcionar de forma normal
			Ausgangsrelais eingeschaltet // Output Relay switched on // relais de sortie est déclenché // relè di uscita è commutato // Relé de salida conectado
ALARM	rot/ red/ rouge/ rosso/ rojo		AS-i-Ausgangsbit A 0 nicht gesetzt // AS-i output bit 0 0 is not set // bit de sortie AS-i S 0 n'est pas mis // bit di uscita AS-i U 0 non è messo // Bit de salida S 0 de AS-i no está puesto
			AS-i-Ausgangsbit A 0 gesetzt // AS-i output bit 0 0 is set // bit de sortie AS-i S 0 est mis // bit di uscita AS-i U 0 è messo // Bit de salida S 0 de AS-i está puesto
I1, I2, I3, 1.Y1	gelb/ yellow/ jaune/ giallo/ amarillo		Der entsprechende Eingang ist nicht geschaltet, oder I3 zeigt an: Freigabe nicht erteilt bei P2=1 //Corresponding input not switched on, or I3 indicates: Release not granted for P2=1 // l'entrée correspondante n'est pas déclenchée, ou I3 indique: validation off, quand P2=1 // l'ingresso relativo non è commutato, o I3 indica: rilascio off, se P2=1 // la entrada correspondiente no está conmutada, o I3 indica: habilitación off, se P2=1
			(Lauflicht // running light // feu fixe // giallo continuo // corriendo luz) Schalter steht auf PRG // Switch is set to PRG // commutateur se trouve sur PRG // commutatore si trova su PRG // El interruptor está en PRG
			Der entsprechende Eingang ist geschaltet, oder I3 zeigt an: Freigabe erteilt bei P2=1 // Corresponding input switched, or I3 indicates: Release granted for P2=1 // l'entrée correspondante est déclenchée, ou I3 indique: validation on, quand P2=1 // l'ingresso relativo è commutato, o I3 indica: rilascio on, se P2=1 // la entrada correspondiente está conmutada, o I3 indica: habilitación on, si P2=1

Issue date: 24.11.2008

LEDs	Colors	Status	Signal // Description
			LED an/on/allumée/on/en
			LED blinkend/flashing/clignotante/ameggiante/el destellar
			LED aus/off/éteinte/fuori/fuera

8.6 Montage

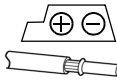

1 x 0.5 - 1.5 mm² (16AWG: min. 24/max.12)

Operating temperature: 0 °C ... +55 °C

Temperature rating for cable: 60/75 °C
Use copper conductors only

	0,8 Nm 7 LB.IN
	Ø 5 ... 6 mm / PZ2
	2 x (0,5 ... 1,5) mm ²
	2 x (0,5 ... 1,5) mm ²
AWG	2 x 24 ...12

auf Montageplatte mit 35-mm-Hutschiene
on mounting plate with 35 mm top-hat rail
sur plaque de montage avec profilé-support 35 mm
su piastra di montaggio con guida DIN 35 mm
sobre placa de montaje con guía simétrica de 35 mm

auf Montageplatte mit 35-mm-Hutschiene
on mounting surface with 35 mm DIN rail
sur plaque de montage avec profilé-support 35 mm
su piastra di montaggio con guida DIN 35 mm
sobre placa de montaje con guía simétrica de 35 mm

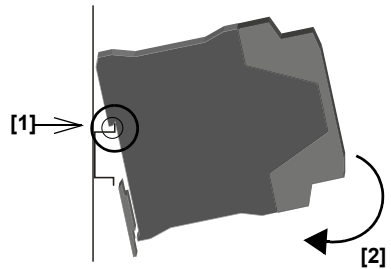

FACTORY AUTOMATION – SENSING YOUR NEEDS



Worldwide Headquarters

Pepperl+Fuchs GmbH
68307 Mannheim · Germany
Tel. +49 621 776-0
E-mail: info@de.pepperl-fuchs.com

USA Headquarters

Pepperl+Fuchs Inc.
Twinsburg, Ohio 44087 · USA
Tel. +1 330 4253555
E-mail: sales@us.pepperl-fuchs.com

Asia Pacific Headquarters

Pepperl+Fuchs Pte Ltd.
Company Registration No. 199003130E
Singapore 139942
Tel. +65 67799091
E-mail: sales@sg.pepperl-fuchs.com

www.pepperl-fuchs.com

 **PEPPERL+FUCHS**
SENSING YOUR NEEDS

Subject to modifications
Copyright PEPPERL+FUCHS • Printed in Germany

TDOCT1692A_ENG
12/2008