

Correct use

Safety switches series VAA-2E...-V1/VAA-2E2A...-V1 are operated as slaves on the safety bus AS-Interface Safety at Work and function as interlocking devices without guard locking (separate actuator). The actuator has a low coding level. In combination with a movable safety guard and the machine control, this safety component prevents dangerous machine functions from occurring while the safety guard is open. A stop command is triggered if the safety guard is opened during the dangerous machine function.

This means:

- ▶ Starting commands that cause a dangerous machine function must become active only when the safety guard is closed.
- ▶ Opening the safety guard triggers a stop command.
- ▶ Closing a safety guard must not cause automatic starting of a dangerous machine function. A separate start command must be issued. For exceptions, refer to EN ISO 12100 or relevant C-standards.

Before the device is used, a risk assessment must be performed on the machine, e.g. in accordance with the following standards:

- ▶ EN ISO 13849-1, Safety of machinery – Safety-related parts of control systems – Part 1: General principles for design
- ▶ EN ISO 12100, Safety of machinery – General principles for design – Risk assessment and risk reduction
- ▶ IEC 62061, Safety of machinery – Functional safety of safety-related electrical, electronic and programmable electronic control systems.

Correct use includes observing the relevant requirements for installation and operation, particularly based on the following standards:

- ▶ EN ISO 13849-1, Safety of machinery – Safety-related parts of control systems – Part 1: General principles for design
- ▶ EN ISO 14119 (supersedes EN 1088), Safety of machinery – Interlocking devices associated with guards – Principles for design and selection
- ▶ EN 60204-1, Safety of machinery – Electrical equipment of machines.

Important!

- ▶ The user is responsible for the proper integration of the device into a safe overall system. For this purpose, the overall system must be validated, e.g. in accordance with EN ISO 13849-2.
- ▶ If the simplified method according to section 6.3 of EN ISO 13849-1:2008 is used for determining the Performance Level (PL), the PL might be reduced if several devices are connected in series.
- ▶ Logical series connection of safe contacts is possible up to PL d in certain circumstances. More information about this is available in ISO TR 24119.
- ▶ If a product data sheet is included with the product, the information on the data sheet applies in case of discrepancies with the operating instructions.

Safety precautions

⚠ WARNING

Danger to life due to improper installation or due to bypassing (tampering). Safety components perform a personal protection function.

- ▶ Safety components must not be bypassed, turned away, removed or otherwise rendered ineffective. On this topic pay attention in particular to the measures for reducing the possibility of bypassing according to EN ISO 14119:2013, section 7.
- ▶ The switching operation must be triggered only by actuators designated for this purpose.
- ▶ Prevent bypassing by means of replacement actuators. For this purpose, restrict access to actuators and to keys for releases, for example.
- ▶ Mounting, electrical connection and setup only by authorized personnel possessing special knowledge about handling safety components.

Function

The safety switch monitors the position of movable safety guards. The switching contacts are actuated on the insertion/removal of the actuator.

When the safety guard is closed, each VAA-2E...-V1/VAA-2E2A...-V1 transmits a switch-specific, unique safety code sequence with 8 x 4 bits via the AS-Interface bus. This code sequence is evaluated by an AS-Interface safety monitor.

The first positively driven contact is represented by the AS-Interface input bits D0 and D1, while the second positively driven contact is represented by D2 and D3.

The safety switch must be correspondingly configured in the AS-Interface safety monitor (refer to the operating instructions of the AS-Interface safety monitor used and the status table).

Selection of the actuator

NOTICE

Damage to the device due to unsuitable actuator. Make sure to select the correct actuator (see table in Figure 3).

Additionally pay attention to the door radius and the fastening options (see Figure 4).

Mounting

NOTICE

Device damage due to improper mounting and unsuitable ambient conditions

- ▶ Safety switches and actuators must not be used as an end stop.
- ▶ Observe EN ISO 14119:2013, sections 5.2 and 5.3, for information about fastening the safety switch and the actuator.
- ▶ Observe EN ISO 14119:2013, section 7, for information about reducing the possibilities for bypassing an interlocking device.
- ▶ Protect the switch head against damage, as well as penetrating foreign objects such as swarf, sand and blasting shot, etc.

Changing the actuating direction

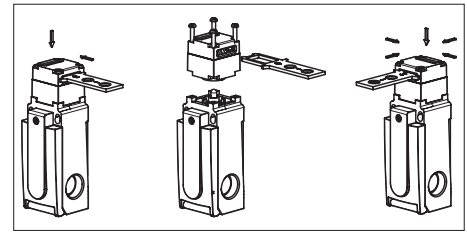

Figure 1: Changing the actuating direction

1. Remove the screws from the actuating head.
2. Set the required direction.
3. Tighten the screws with a torque of 0.8 Nm.
4. Cover the unused actuating slot with the enclosed slot cover.

Electrical connection

The safety switch is connected to the bus system with a 4-pin connecting cable with M12 plug connector via a passive AS-Interface distribution box with a yellow and black AS-Interface cable.

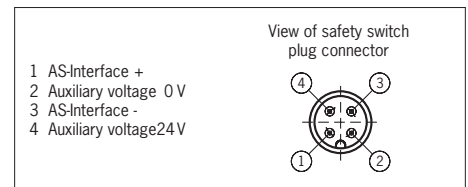

Figure 2: Terminal assignment of M12 plug connector

The following information applies to devices with plug connector:

- ▶ Check that the plug connector is sealed.

Setup

Setting the AS-Interface address

The address can be set prior to or after assembly.

The AS-Interface address of the safety switch is set using an AS-Interface programming device. Addresses 1 to 31 are valid.

The unit is programmed by connecting the programming device to the M12 plug connector of the safety switch with a programming cable.

Address 0 is the default setting on delivery (the AS-Interface Fault LED is lit during operation).

Configuration in the AS-Interface safety monitor

(see operating instructions for the AS-Interface safety monitor and status table)

The safety switch is configured in the AS-Interface safety monitor with the AS-Interface address set as follows, for example:

- ▶ Dual-channel dependent
- ▶ Synchronization time: typ. 3 s

It may be necessary to set the synchronization time to higher values. This depends on the application and the approach speed of the actuator.

- ▶ With start-up test (corresponding to risk analysis)

In this operation mode, the safety guard must be opened each time prior to restarting in order to perform the start-up test.

LED indicators

The AS-Interface bus status is indicated by two LEDs (Power, Fault) behind the lock cover on the safety switch.

Function test

⚠ WARNING

Fatal injury due to faults during the function test.

- ▶ Before carrying out the function test, make sure that there are no persons in the danger area.
- ▶ Observe the valid accident prevention regulations.

Check the device for correct function after installation and after every fault.

Proceed as follows:

Mechanical function test

The actuator must slide easily into the actuating head. Close the safety guard several times to check the function.

Electrical function test

1. Switch on operating voltage.
2. Close all safety guards.
- ➔ The machine must not start automatically.
3. Start the machine function.
4. Open the safety guard.
- ➔ The machine must switch off and it must not be possible to start it as long as the safety guard is open.

Repeat steps 2 - 4 for each safety guard.

Inspection and service

⚠ WARNING

Danger of severe injuries due to the loss of the safety function.

- ▶ If damage or wear is found, the complete switch and actuator assembly must be replaced. Replacement of individual parts or assemblies is not permitted.
- ▶ Check the device for proper function at regular intervals and after every fault. For information about possible time intervals, refer to EN ISO 14119:2013, section 8.2.

Inspection of the following is necessary to ensure trouble-free long-term operation:

- ▶ correct switching function
- ▶ secure mounting of all components
- ▶ damage, heavy contamination, dirt and wear
- ▶ sealing of cable entry
- ▶ loose cable connections or plug connectors.

Information: The year of manufacture can be seen in the bottom, right corner of the type label.

Exclusion of liability and warranty

In case of failure to comply with the conditions for correct use stated above, or if the safety instructions are not followed, or if any servicing is not performed as required, liability will be excluded and the warranty void.

Notes about

For use and operation as per the requirements of  (UL), an isolating transformer or a power supply with secondary overcurrent protection (3 A) must be used.

EC declaration of conformity

The manufacturer named below herewith declares that the product fulfills the provisions of the directive(s) listed below and that the related standards have been applied.

Pepperl+Fuchs GmbH
Lilienthalstr. 200
68307 Mannheim, Germany

Directives applied:

- ▶ Machinery Directive 2006/42/EC

Standards applied:

- ▶ EN 60947-5-1:2004 + Cor.:2005 + A1:2009
- ▶ EN 1088:1995+A2:2008
- ▶ EN 14119:2013

The original EC declaration of conformity can also be found at: www.pepperl-fuchs.de

Technical data

Parameter	Value
Housing material	Reinforced thermoplastic
Degree of protection acc. to IEC 60529	IP 67, mating connector inserted
Mechanical life	2 x 10 ⁶ operating cycles
Ambient temperature	-20 ... +55 °C
Degree of contamination (external, acc. to EN 60947-1)	3 (industrial)
Installation position	Any
Approach speed, max.	20 m/min
Extraction force	25 N
Retention force	10 N
Actuating force, max.	25 N
Actuation frequency	6,700/h
Switching principle	2 positively driven contacts, slow-action switching contact
Connection	Plug connector M12, 4-pin
Weight	Approx. 0.16 kg
AS-Interface data acc. to AS-Interface specification 2.1	EA code: 7 ID code: B
Operating voltage AS-Interface	DC 22.5 ...31.6 V
Total current consumption, max.	45 mA
Valid AS-Interface addresses	1 - 31
AS-Interface inputs	Acc. to AS-Interface Safety at Work
Positively driven contact 1	D0, D1
Positively driven contact 2	D2, D3
AS-Interface outputs	
D1	Red LED, 1 = LED on
D2	Green LED, 1 = LED on
AS-Interface Power LED	Green, AS-Interface Power on
AS-Interface Fault LED	Red, offline phase or address 0"
Reliability values acc. to EN ISO 13849-1	
B _{10L}	3 x 10 ⁶

Status table

Programming	State	D0, D1	D2, D3	Monitor diagnosis
Dual channel dependent Synchronization time 3 s	Safety guard closed	Code sequence		Green If start-up test selected: Yellow flashing on start-up
	Intermediate state during opening or closing of the safety guard. Switch S1 (internal) open	Half-sequence	00	During opening: Yellow flashing During closing: Red After expiration of the synchronization time: Yellow flashing
	Intermediate state during opening or closing of the safety guard. Switch S2 (internal) open	00	Half-sequence	
	Safety guard open	00	00	Red
	Address 0 or communication disrupted	-		Gray

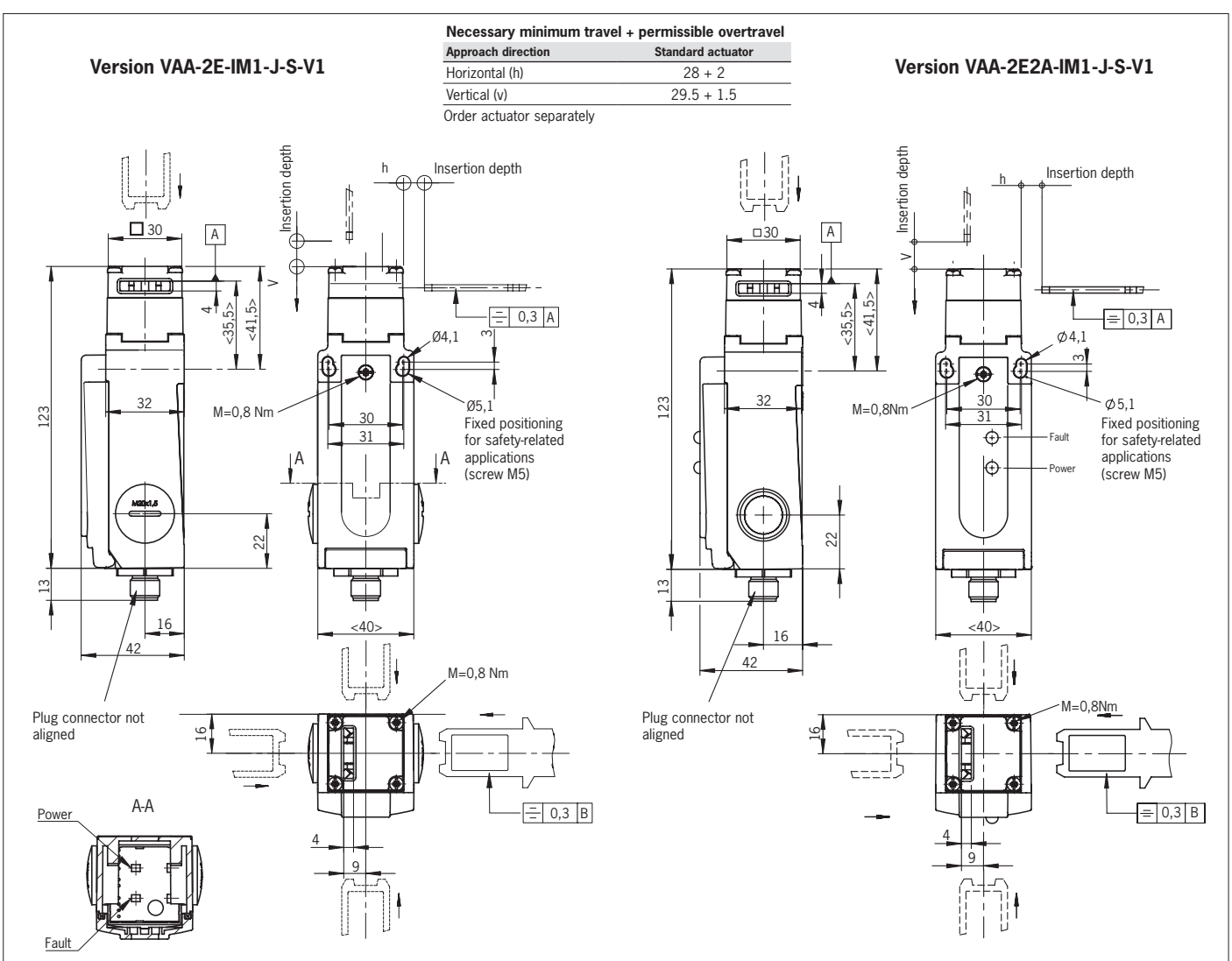

Figure 3: Dimension drawing

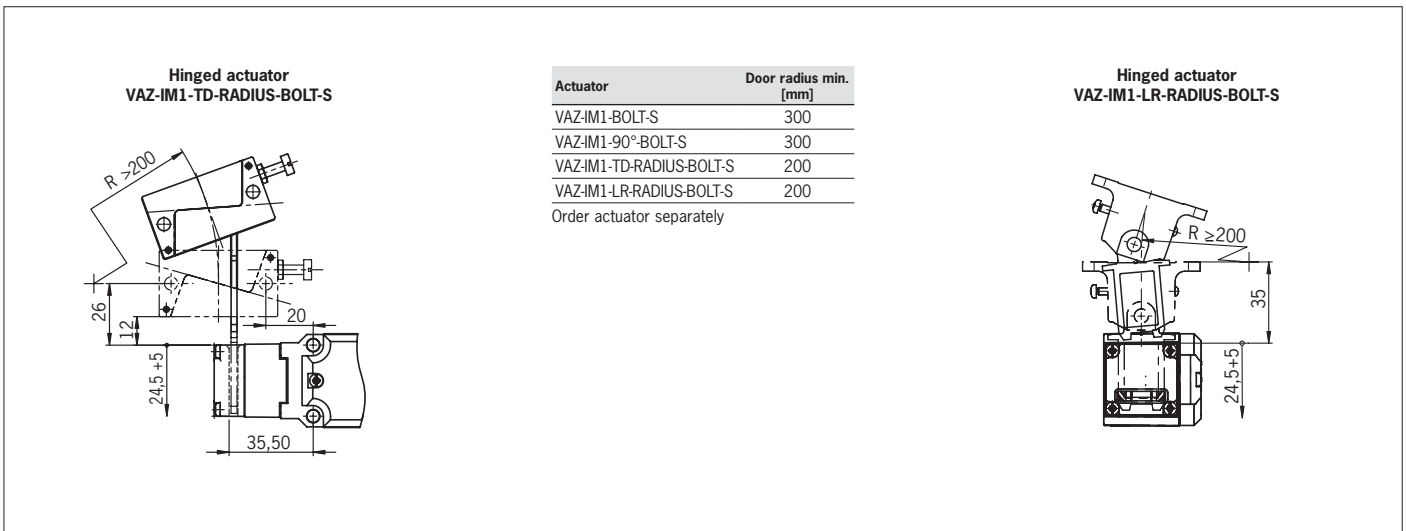

Figure 4: Minimum door radii