

Introduction

The H-System offers the ideal Termination Board solution for Experion Series C GI/IO and SMS hazardous location applications. The design of an H-System project is optimized with HART Communication Boards and a complete range of accessories. The H-System includes a wide range of plug-in, isolated barriers that are mounted on Termination Boards. The H-System is easy to specify, integrate and expand and has become synonymous with safety and reliability.

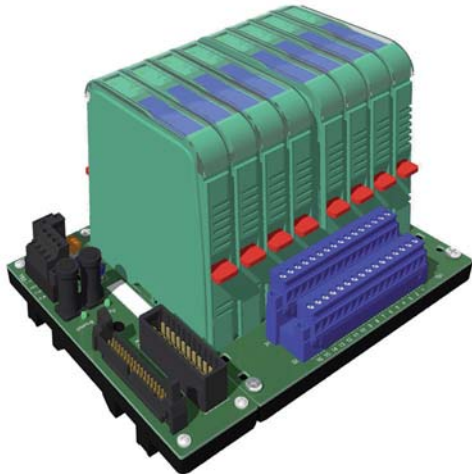

Figure 1 H-System Termination Board for SMS with isolated barriers

Modules and Termination Boards

Depending on the functionality and application, the H-System barriers have two housing widths, the 12.5 mm HiC modules and the 18 mm HiD modules, all with the features and interoperability of the H-System. The board can be coded in combination with the modules to ensure the safety relevant data is maintained for the connected field devices.

HiC module housing

Used for high signal integrity

- Small housing, only 12.5 mm wide
- Highest packing density in single loop integrity



Figure 2 12.5 mm housing (HiC module)

HiD module housing

Used for high channel density

- Compact 18 mm housing
- High channel density
- As low as 4.5 mm per channel

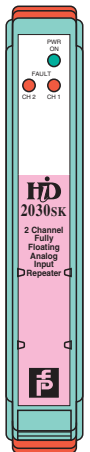

Figure 3 18 mm housing (HiD module)

Termination Boards

- For HiC and HiD isolated barrier modules
- 8- or 16-position Termination Boards
- Redundant and fused powered
- Diagnostic and fault monitoring

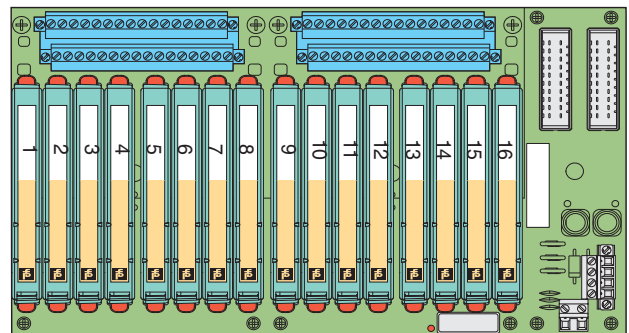

Figure 4 16-position Termination Board

Accessories

HART Communication Board

The HART Communication Board can interface with HART enabled H-System Termination Boards. It contains one slot to mount the 32-channel HART multiplexer type HiD Mux2700.

Pre-assembled cables provide easy connection between the H-System Termination Boards, the HART Communication Board and the Honeywell Safety Manager System.

It offers redundantly fused, power supply connections with LED indication. Redundant RS 485 terminals are also available and can be wired in a daisy chain configuration.

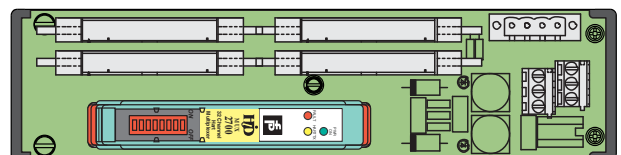

Figure 5 HART Communication Board

DOCT-1728A 04/2009

Label carrier

The label carrier set type HiALC-HI*TF-SET-*** provides much space for tagging. In addition the side plates of the label carrier enlarge the distance between IS terminals and non-IS terminals. Therefore further measures to ensure the required tight string length of ≥ 50 mm omit.

Topology

This figure illustrates a typical H-System solution. It contains a Termination Board and a HART Communication Board.

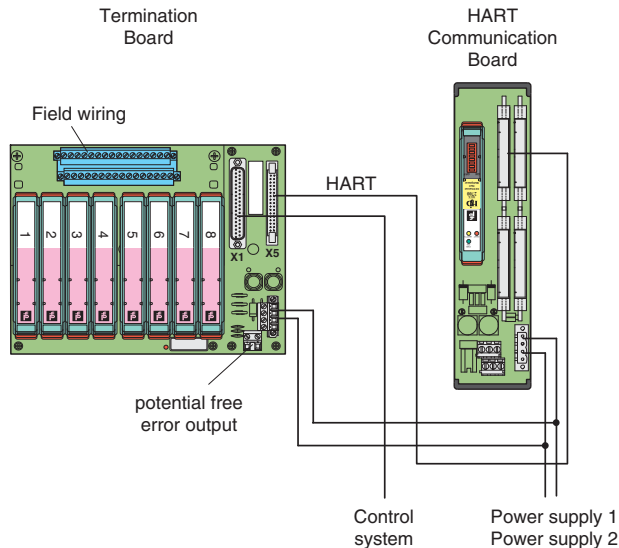

Figure 6 H-System topology

Mounting

The Termination Boards are mounted on a 35 mm DIN rail. The DIN rail is centered under the Termination Board.

The H-System Termination Boards have been designed for protection category IP20 with isolated barriers installed (IP00 without modules) according to EN 60529; therefore, the boards must be appropriately protected against splashing water and contamination.

Mounting the Termination Board

- Place the Termination Board onto the DIN rail (Figure 7).
- Tighten the fastening screws (Figure 8).

The Termination Board is now properly mounted and secured.

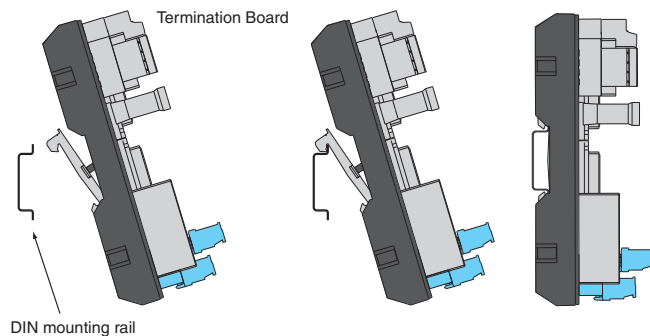

Figure 7 Proper mounting of the H-System Termination Board

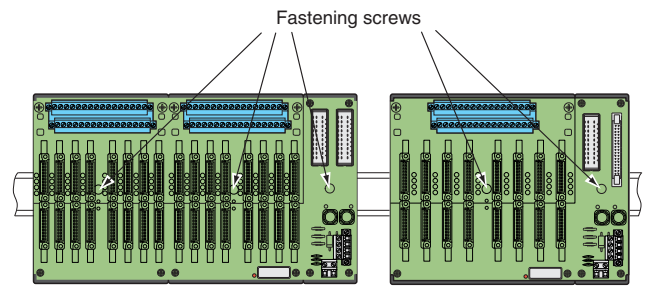

Figure 8 Top view of the H-System Termination Board

Mounting the module on the Termination Board

- Ensure that the red Quick Lok Bar (1) is in the upper position.
- Observe the plug orientation of the device. Insert the coding pins (2) of the module in the corresponding coding holes on the board. Now center the adjustment pins (3) to the adjustment holes on the Termination Board.
- Carefully press the device into the contacts and adjustment holes.
- For the mechanical adjustment of the module press the red Quick Lok Bar (1) down on either side of the device (see Figure 9)

This completes the mounting of a module.

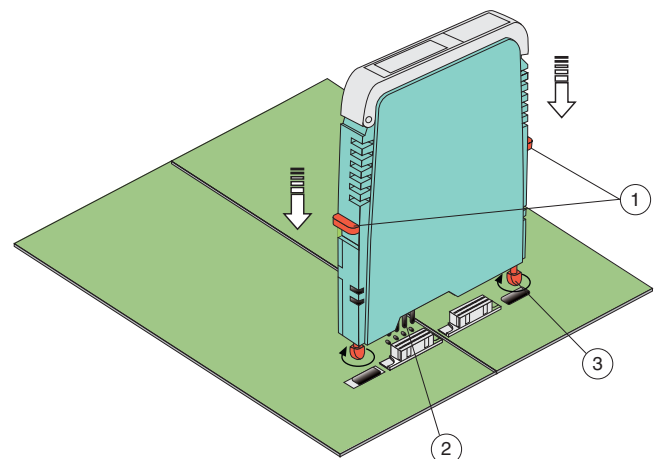

Figure 9 Proper mounting of an H-System isolated barrier

DOCT-1728A 04/2009

Terminal designation

Field side

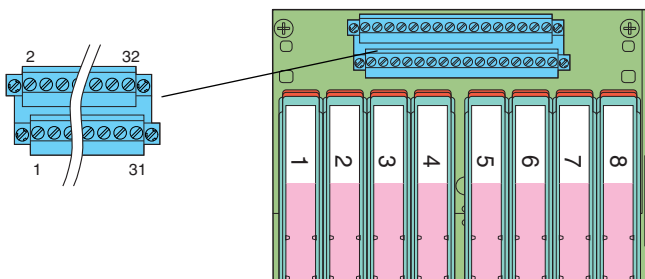

Figure 10 Example: field side arrangement of the terminals

Control side

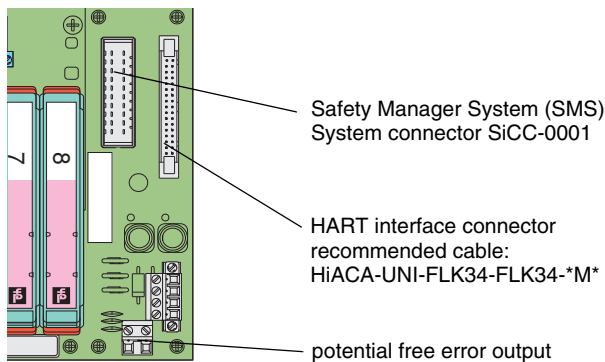

Figure 11 Example: control side arrangement of the terminals (SMS)

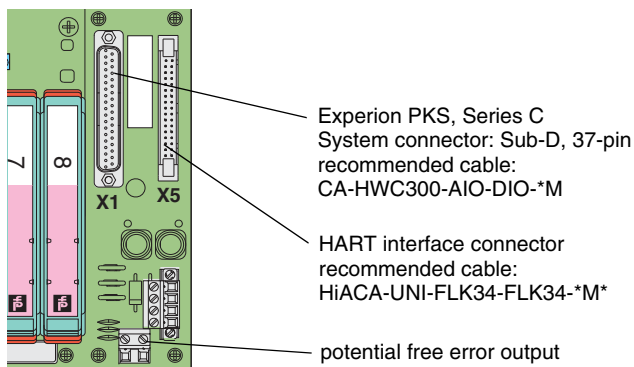

Figure 12 Example: control side arrangement of the terminals (Series C)

System cables

The Honeywell IOTAs and IS boards are connected with H-System Termination Boards via plug-n-play system cables. These system cables reducing risks and reconnection time during site installations.

Just one type of system cable serves all Series C Termination Boards and one type serves all SMS Termination Boards.

Typical cabinet layout

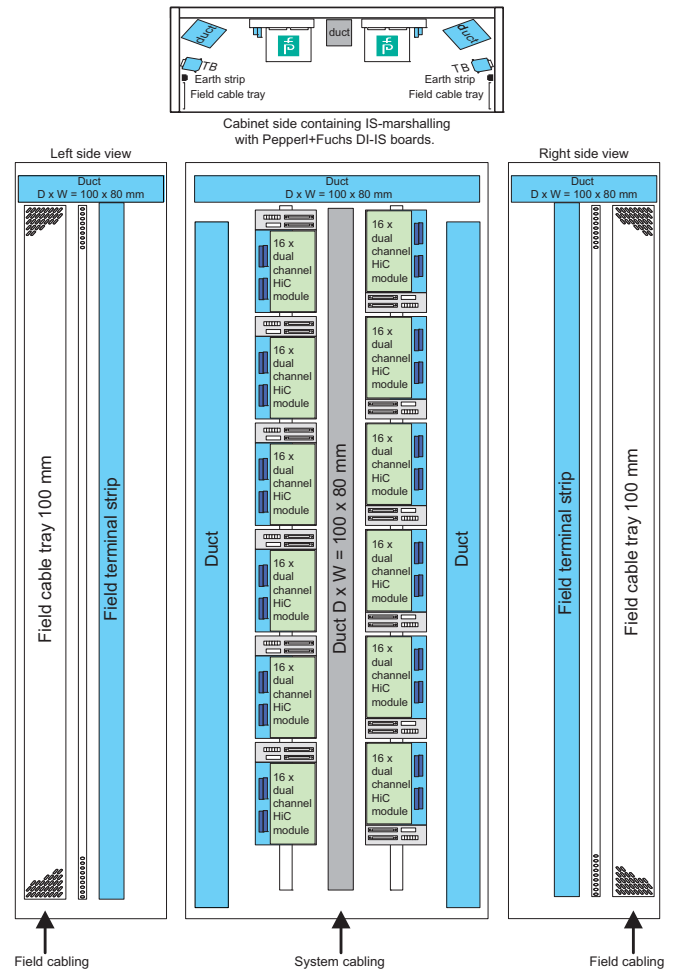
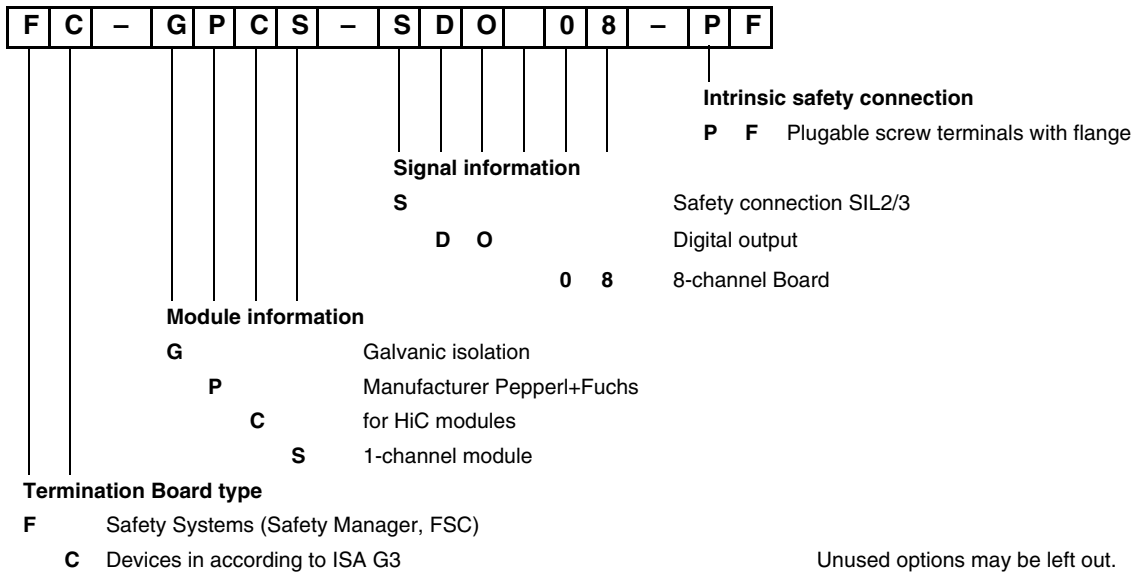

Figure 13 Example: marshalling cabinet layout

Pepperl+Fuchs Termination Boards enable concurrent assembly of system cabinets and marshalling cabinets shortening the project life cycle.

IS Termination Boards can be located close to the field terminals.

Example: Honeywell FC-GPCS-DO08-PF



Example: Honeywell SC-GPCS-UNI16-PF

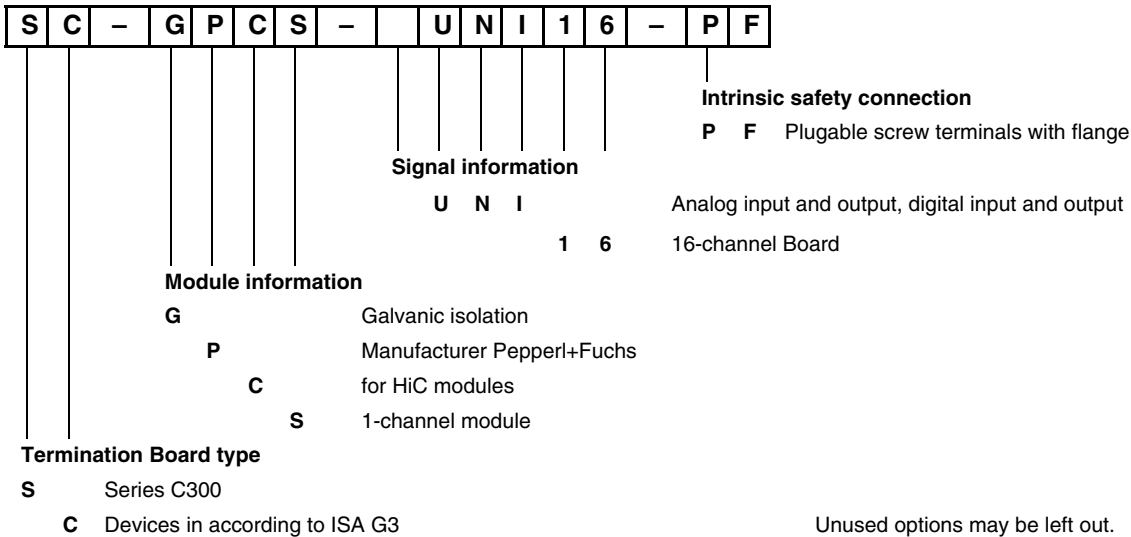

DOCT-1728A 04/2009

Safety information

The corresponding data sheets, the Declaration of Conformity, the EC-Type Examination Certificate and applicable certificates (see data sheet) are an integral part of this document.

Intended use

Laws and regulations applicable to the usage or planned purpose of usage must be observed. Devices are only approved for proper usage in accordance with intended use. Improper handling will result in voiding of any warranty or manufacturer's responsibility.

These devices are used in C&I technology for the galvanic isolation of C&I signals, such as 20 mA and 10 V unit signals, and also for the adaptation and/or standardization of signals. Devices which have intrinsically safe control circuits are used to operate field devices within hazardous areas.

The devices are not suitable for the isolation of signals in power engineering, unless this is specifically referred to in the respective data sheet.

Protection of operating personnel and the system is not ensured if the product is not used in accordance with its intended use.

Intrinsic safety circuits that were operated with circuits of other types of protection may not be used as intrinsically safe circuits afterwards.

Installation and commissioning

Commissioning and installation must be carried out by specially trained and qualified personnel only.

Installation of the interface devices in the safe area

The devices are constructed to satisfy the IP20 protection classification and must be protected from adverse environmental conditions such as water spray or dirt exceeding the pollution degree 2.

The devices must be installed outside the hazardous area!

Depending on the level of protection, the intrinsically safe circuits of the devices (light blue identification on the device) can be located in the hazardous area. It is especially important to ensure that the intrinsically safe circuits are safely separated from all non-intrinsically safe circuits.

The installation of the intrinsically safe circuits is to be conducted in accordance with the relevant installation regulations.

The respective peak values of the field device and the associated device with regard to explosion protection should be considered when connecting intrinsically safe field devices with the intrinsically safe circuits of H-System devices (demonstration of intrinsic safety). EN 60079-14/ IEC 60079-14 or NEC and CEC electrical codes for US and Canada respectively must be observed (where appropriate). If available, also the product certification control drawing must be observed.

If more channels of one device are to be connected in parallel, it must be ensured that the parallel connection is made directly at the terminals. For the demonstration of intrinsic safety, the maximum values of the parallel connection are to be regarded.

The EC-Type Examination Certificates or standard certificates/approvals should be observed. It is especially important to observe the "special conditions" if these are included in the certificates.

Installation and commissioning of the interface devices within Zone 2/Div. 2 of the hazardous area

Only devices with the corresponding manufacturer's Declaration of Conformity or separate certificate of conformity can be installed in Zone 2/Div. 2.

The individual data sheets indicate whether these conditions are met.

For US and Canada installations, in Zone 2/Div. 2 follow the NEC and CEC wiring methods. The enclosure must be able to accept Zone 2/Div. 2 wiring methods. The referenced product certification control drawing must be observed.

For all other applications, the devices should be installed in a switch or junction box that:

- meets at least IP54 in accordance to EN 60529.
- meets to the requirements of resistance to light and resistance to impact according to EN 60079-0/ IEC 60079-0.
- meets to the requirements of thermal endurance according to EN 60079-15/IEC 60079-15.
- must not cause ignition danger by electrostatic charge during intended use, maintenance and cleaning.

Depending on the level of protection, the intrinsically safe circuits of the devices (light blue identification on the device) can be located in the hazardous area. It is especially important to ensure that the intrinsically safe circuits are safely separated from all non-intrinsically safe circuits.

The installation of the intrinsically safe circuits is to be conducted in accordance with the relevant installation regulations.

The respective peak values of the field device and the associated device with regard to explosion protection should be considered when connecting intrinsically safe field devices with the intrinsically safe circuits of H-System devices (demonstration of intrinsic safety). EN 60079-14/ IEC 60079-14 or NEC and CEC electrical codes for US and Canada respectively must be observed (where appropriate). If available, also the product certification control drawing must be observed.

If more channels of one device are to be connected in parallel, it must be ensured that the parallel connection is made directly at the terminals. For the demonstration of intrinsic safety, the maximum values of the parallel connection are to be regarded.

The EC-Type Examination Certificates, standard certificates/approvals or the manufacturer's Declaration of Conformity should be observed. It is especially important to observe the "special conditions" if these are included in the certificates.

Repair and maintenance

The transfer characteristics of the devices remain stable over long periods of time. This eliminates the need for regular adjustment. Maintenance is not required.

Fault elimination

No changes can be made to devices which are operated in hazardous areas. Repairs on the device are not allowed.

Isolation coordinates for devices with Ex-certificate according to EN 50020 and EN 60079-11

The devices are assessed for pollution degree 2 and overvoltage category II according to EN 50178.

Isolation coordinates for installations for galvanic isolation according to EN 50178 and EN 61140

The devices of the H-System are electronic equipment for use in secluded electrical operating sites where only skilled personnel or electrically instructed personnel will have admission or access.

The devices are assessed for pollution degree 2 and overvoltage category II according to EN 50178.

For additional details, see data sheets.

Technical data

Electrical data

Power supply (modules)

24 V DC -15 %, +25 %, (20.4 V DC to 30 V DC)

Each module is protected internally. The Termination Boards have redundant power supply connections with fuses that can be replaced by the customer.

Mechanical data

Location

Mounting outside hazardous areas possible as well as in Zone 2/Div. 2 where a manufacturer's Declaration of Conformity exists.

Protection degree

- Termination Boards: IP20 with modules plugged in (IP00 without modules)
- Modules: IP20

Mass

Termination Boards:

- Board for 8 HiC modules approx. 450 g
- Board for 16 HiC modules approx. 900 g
- Board for 8 HiD modules approx. 500 g
- Board for 16 HiD modules approx. 1000 g

Modules:

- HiC module approx. 100 g
- HiD module approx. 140 g

Material

Modules: Polycarbonate

Termination Boards: Polycarbonate, fiber glass reinforced

Dimensions (L x W x H)

Termination Boards (height inclusive module assembly):

- Board for 8 HiC modules: 159 x 155 x 153 mm
- Board for 16 HiC modules: 273 x 155 x 153 mm
- Board for 8 HiD modules: 201 x 155 x 153 mm
- Board for 16 HiD modules: 357 x 155 x 153 mm

Modules:

- HiC module: 12.5 x 106 x 130 mm
- HiD module: 18 x 106 x 130 mm

Housing drawings please refer to the appendix.

Labeling

A plastic label holder is available on the front of the module:

- HiC modules, HiD modules: 35 x 10.5 mm

A large label carrier kit HiALC-... for the Termination Boards is available.

Fire protection class

Housing: V2 according to UL 94 standard. (Unless stated otherwise all details relate to the reference conditions.)

Ambient conditions

Ambient temperature:

-20 °C to 60 °C, (273 K to 333 K)

Storage temperature:

-40 °C to 70 °C, (253 K to 343 K)

Relative humidity:

max. 95 % no moisture condensation

Reference conditions

- temperature: 23 °C (296 K)
- relative humidity: 50 %
- supply voltage: 24 V DC
- working resistance, where applicable: 250 Ω
- full scale value: 20 mA

Conformity with standards and directives

General

- Isolator modules with and without explosion protection, mostly with Ex ia IIC/Class I Div. 1, international approvals
- EMC acc. to NAMUR NE21 and EN 61326
- LEDs acc. to NAMUR NE44
- Software acc. to NAMUR NE53

Digital inputs/outputs according to NAMUR

The standards references for this interface have changed many times:

German standard (old): **DIN 19234**: Electrical distance sensors – DC interface for distance sensors and switch amplifiers; 1990-06

European standard (old): **EN 50227**: Low voltage switch gear and control gear – control devices and switching elements – proximity switches, DC interface for proximity sensors and switch amplifiers (NAMUR), 1996-10

German version (old): **DIN EN 50227**: Low voltage switch gear – control devices and switching elements – proximity switches, DC interface for proximity sensors and switch amplifiers (NAMUR), 1997, German nomenclature VDE 0660, part 212

Current designation: DIN EN 60947-5-6: Low voltage switch gear – control devices and switching elements – proximity switches, DC interface for proximity sensors and switch amplifiers (NAMUR), 2000, German nomenclature. VDE 0660 part 212

Current IEC designation: IEC 60947-5-6: Low voltage switch gear and control gear – part 5-6: Control circuit devices and switching elements – DC interface for proximity sensors and switching amplifiers (NAMUR), 1999.