



Application Guideline

Specification Proposal for FOUNDATION™ Fieldbus

Based on international and US standards

FOUNDATION™ Fieldbus is used in a wide range of different applications. Typically for each application a dedicated specification is required.

This document is a guideline regarding physical layer parameters. It serves as a cookbook recipe for the preparation of requests for proposals and quotations. It provides guidelines so that constraints are met, which have to be observed for successful planning of FOUNDATION™ Fieldbus H1 infrastructure. Special focus is given to application in hazardous areas Class I, Division 1 and 2.

This document is based on IEC and US standards like NEC, FM, UL etc.

Prepared by:

Thomas Klatt
Business Development Manager

Bernd Schuessler
Product Manager Bus Systems

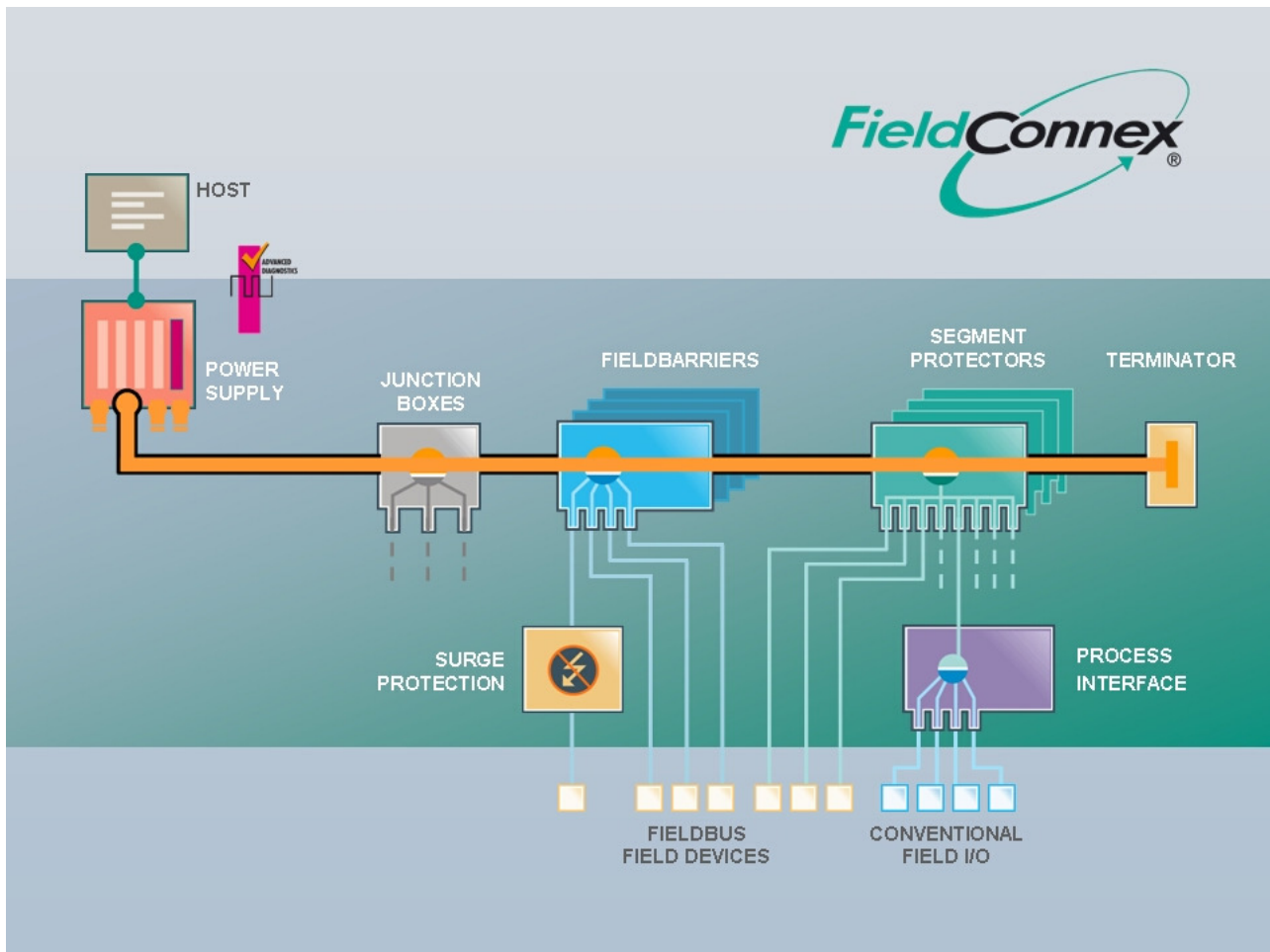

Pepperl+Fuchs is the proven market leader for innovative and highly available components for your fieldbus according to IEC 61158-2. With quality components to fit your process automation system and demands in the field our highly reliable and energy-efficient design allows you to focus on the task at hand. Knowing that your fieldbus is running.

The High-Power Trunk Concept with Entity or FISCO devices: Connect the maximum number of devices to the same fieldbus trunk; and at the same time make use of maximum cable lengths. This concept utilizes standard power supplies such as the easy to install and configuration free Power Hub. Segment Protectors and FieldBarriers are installed close to field devices and limit the energy at the spur. You are free to work on field devices without hot work permit.

Advanced Diagnostics: Take control of your fieldbus installation. This latest innovation brings transparency to fieldbus. Speed up commissioning with automated documentation. Measure fieldbus performance and detect changes in the control room before they become critical to your plants operation.

You can rely on products built to serve your every need in fieldbus for process automation. You can gain from the experience of knowledgeable engineers to create your fieldbus solution. You can be at ease with products and solutions from Pepperl+Fuchs.

Specification Proposal for FOUNDATION™ Fieldbus

Content

1.	Scope.....	3
2.	Purpose	3
3.	Definitions and Abbreviations.....	3
3.1.	Definitions.....	3
3.1.1.	General	3
3.2.	FOUNDATION Fieldbus Definitions.....	3
3.3.	Abbreviations	7
4.	FIELDBUS SYSTEM OVERVIEW	8
4.1.	Project Objectives	8
4.2.	Overall System Configuration	9
4.2.1.	General	9
4.2.2.	Integration of Control Function in DCS Controller	9
4.2.3.	Integration of Operation and Monitoring.....	9
4.2.4.	Integrated Engineering Function in DCS	9
5.	Field system design guidelines	10
5.1.	General	10
5.2.	Fieldbus Application.....	11
5.3.	Field Device Selection.....	12
5.3.1.	Interoperability	12
5.3.2.	Fieldbus Function Blocks	13
5.3.3.	Field Device Management	14
5.3.4.	Field Device Power	14
5.3.5.	Link Master Devices.....	14
5.3.6.	Device Upgrading	14
5.4.	Critical Loop definition and Application	14
5.4.1.	Level 1	14
5.4.2.	Level 2	15
5.4.3.	Level 3	15
5.5.	Control Assignment.....	16
5.6.	Segment Grouping.....	16
5.7.	Temperature Transmitters (Multiple type).....	16
5.8.	Required macrocycle times	16
5.9.	Hazardous Area Classification	17
5.10.	Redundancy.....	18
5.11.	Physical Device Loading Requirements on H1 Bus... 18	
5.11.1.	General Requirements.....	18
5.11.2.	Requirements for Non-Ex Application.....	19
5.11.3.	Requirements for Class I, Div 2 application	19
5.11.4.	Requirements for Class I, Div 1 application	19
5.12.	Fieldbus Power Supply Requirements	21
5.12.1.	Additional Fieldbus Power Supply Requirements.....	21
5.13.	Segment Spare Philosophy Requirements	22
5.13.1.	Segment Execution Time Requirements	23
5.14.	Segment Wiring Design Requirements.....	23
5.14.1.	Overall Wiring Design Philosophy.....	23

5.14.2.	Topology.....	24
5.14.3.	Cable Type.....	24
5.14.4.	Cable Length	25
5.14.5.	Power Consumption	25
5.14.6.	Minimum Operating Voltage.....	26
5.14.7.	Attenuation.....	26
5.14.8.	Example Calculation.....	26
5.14.9.	Segment Design Validation Tool	28
5.14.10.	Enclosure Requirements.....	28
5.14.11.	Wiring Block Requirements.....	29
5.14.12.	Grounding of Screens	30
5.14.13.	EMC protection.....	30

Specification Proposal for FOUNDATION™ Fieldbus

1. Scope

This document

- defines FOUNDATION™ Fieldbus system design requirements for the physical layer.
- gives information which additional requirements needs to be defined.
- is based on international and European standards when fieldbus will be used in hazardous areas.

2. Purpose

The purpose of the document is to define the FOUNDATION™ Fieldbus system design requirements to:

- Ensure consistency across the entire project.
- Minimize the validation requirement.
- Minimize commissioning related problem.

3. Definitions and Abbreviations

3.1. Definitions

3.1.1. General

- Shall refers to a mandatory requirement
- Should refers to a recommendation
- May refers to one acceptable course of action

3.2. FOUNDATION™ Fieldbus Definitions

The following table explains definitions of fieldbus terms used within this procedure, however, a comprehensive list of definitions can be found at the Foundation web site www.fieldbus.org.

Terms and definitions:

Term	Definition
Basic Function Block (FB)	Basic Function Blocks (FBs) are built into FF services as needed to achieve the desired control functionality. Automation functions provided by Basic FBs include Analogue Input (AI), Analogue Output (AO) and Proportional/Integral/Derivative (PID) control and others. The Fieldbus Foundation has released specifications for 10 types of basic FBs. There can be many types of FBs in a device. The order and definition of basic FB parameters are fixed and defined by the specifications.

Term	Definition
Bus	A H1 Fieldbus cable between a host and field devices connected to multiple segments, normally through the use of repeaters.
Common File Format (CFF)	A software file used by the Host to know the device detailed FF capabilities without requiring the actual device.
Control loop	A Control loop contains all field instruments which are needed to close the loop (Sensor and actuator). E.g. Pressure transmitter and valve.
Device Description (DD)	A Device Description (DD) provides an extended description of each object in the Virtual Field Device (VFD), and includes information needed for a control system or host to understand the meaning of data in the VFD.
Fieldbus	A Fieldbus is a digital, two-way, multi-drop communication link among intelligent measurement and control devices. It serves as a Local Area Network (LAN) for advanced process control, remote input/out and high-speed factory automation applications.
FF device (Fieldbus device)	A field device which is connected directly to an H1 fieldbus.
FieldBarrier	A wiring component which changes over from a Non IS trunk to IS outputs. The outputs comply to IEC 60079-27 (FISCO) and the Entity model. Therefore field devices which complies to the FOUNDATION™ fieldbus profiles 111, 112, 121,122, 511 and 512 can be connected to the FieldBarrier
FISCO (Fieldbus Intrinsically Safe Concept)	Allows more power to an IS segment for approved FISCO devices, allowing for more devices per IS segment. Avoids the need to calculated inductances and capacitances for the proof of intrinsic safety and reduces the required work for this proof.

Term	Definition
Function Block (FB)	<p>Function Blocks are incorporated into fieldbus devices to achieve the desired device functionality, as well as to define a wide range of features and behaviours that must work in a standard way for devices to interoperate. For example, a simple transmitter may contain an Analogue Input (AI) function block. A control valve might contain a Proportional/Integral/Derivative (PID) function block as well as the expected Analogue Output (AO) block. Thus, a complete control loop can be built using only a simple transmitter and a control valve.</p> <p>The FOUNDATION™ Fieldbus technology differentiates between</p> <ul style="list-style-type: none"> Basic function blocks Advanced function block Flexible function blocks SIS function blocks
H1	H1 is a term used to describe a Fieldbus network operating at 31.25 kbit/second.
HIST	Host Interoperability Support Testing performed by the Foundation to approve Host conformance to the FF Specifications
Home run	See trunk.
Interchangeability	Interchangeability is the capability to substitute a device from one manufacturer with that of another manufacturer on a fieldbus network without loss of functionality or degree of integration.
ITK	Interoperability Test Kit used by the foundation to register devices and confirm compliance with the relevant FOUNDATION standards. This is a pass/fail test. Only devices passing the full suite of tests receive the foundation's official registration mark. The resource block contains the device approved ITK level
Link	A Link is the logical medium by which H1 Fieldbus devices are interconnected. It is composed of one or more physical segments interconnected by bus Repeaters or Couplers. All of the devices on a link share a common schedule which is administered by that link's current LAS
Link Active Scheduler (LAS)	A Link Active Scheduler (LAS) is a deterministic, centralized bus scheduler that maintains a list of transmission times for all data buffers in all devices that need to be cyclically transmitted. Only one Link Master (LM) device on an H1 Fieldbus Link can be functioning as that link's LAS.

Term	Definition
Link Master (LM)	A Link Master (LM) is any device containing Link Active Scheduler (LAS) functionality that can control communications on an H1 Fieldbus Link. There must be at least one LM on an H1 Link; one of those LM devices will be elected to serve as LAS.
Monitoring loop	Contains Field devices whose values are not used in control loops.
Resource Block (RB)	A Resource Block (RB) describes characteristics of the FF device such as the device name, manufacturer and serial number. There is only one Resource Block (RB) in a device.
Schedule	A schedule defines when a Function Block (FB) shall be executed and when data and status shall be published on the bus.
Segment	A Segment is a section of an H1 Fieldbus that is terminated in its characteristic impedance. Segments can be linked by devices to form a longer H1 Fieldbus.
Segment Protector	A wiring component which allows a quick connection of field devices to the bus. Segment Protectors are offering typically a trunk input, trunk output and between 4 and 12 spur connections. The spurs are short circuit protected.
Spur	A Spur is an H1 branch line connecting to the Trunk that is a final circuit.
Terminator	A Terminator is an impedance matching module used at or near each end of a transmission line. Two Terminators must be used on each H1 segment.
Tick Marked	Tick marked FF devices are those with validated compliance with FOUNDATION™ Fieldbus specifications:.
Topology	The segment structure; Bus-, Tree-, Daisy Chain topology, etc. are examples.
Transducer Block (TB)	A Transducer Block (TB) decouples Function Blocks (FBs) from the local Input/Output (I/O) functions required to read sensors and command output hardware. Transducer Blocks (TBs) contain information such as calibration date and sensor type. There is usually one TB channel for each input or output of a Function Block (FB).
Transmitter	A Transmitter is an active fieldbus device containing circuitry which applies a digital signal on the bus.

Term	Definition
Trunk	A Trunk is the main communication highway between devices on an H1 Fieldbus network. The Trunk acts as source of main supply to spurs on the network.
Virtual Communication Relationship (VCR)	Configured application layer channels that provide for the transfer of data between applications. FOUNDATION™ fieldbus describes three types of Virtual Communication Relationships (VCRs): Publisher/Subscriber, Client/Server, and Source/Sink
Virtual Field Device (VFD)	A Virtual Field Device (VFD) is used to remotely view local device data described in the object dictionary. A typical device will have at least two Virtual Field Devices (VFDs).

3.3. Abbreviations

The following list gives the used abbreviations in this document.

Abbreviations

Abbreviations	Description
AI	Analogue Input
AO	Analogue Output
AWG	American Wire Gauge
CCR	Central Control Room
CFF	Common File Format
DCS	Distributed Control System
DI	Discrete Input
DD	Device Description
DO	Discrete Output
EI	Early Involvement
EC	Engineering Contractor
EITT	Eight Input Temperature Transmitter
FB	Function Block
FCS	Field Control Station
FCU	Field Control Unit
FF	Foundation™ Fieldbus
FGS	Fire & Gas Detection System

Abbreviations	Description
FISCO	Fieldbus Intrinsic Safety Concept
FPS	Fieldbus Power Supply
HART	Highway Addressable Remote Transmitter
HIST	Host Interoperability Support Testing
HIS	Human Interface Station
HIS	Human Interface Station with having system builder function
I/O	Input/Output
IS	Intrinsic Safety
ITK	Interoperability Test Kit
LAN	Local Area Network
LAS	Link Active Schedule
MOV	Motor Operated Valve
MVC	Transmitter Measurement, Validation & Comparison
PID	Proportional/Integral/Derivative Control
PMC	Project Management Contractor
PLC	Programmable Logic Controller
UOM	Units of Measurements
SIS	Safety Instrumented system
TM-I	Temperature Multi Input Device
UPS	Uninterrupted Power Supply
VCR	Virtual Communication Relationship
VFD	Virtual Field Device

4. FIELDBUS SYSTEM OVERVIEW

4.1. Project Objectives

The Distributed Control System should be based on the Open System Architecture concept with Foundation™ Fieldbus (FF) interfacing capabilities to smart devices in the field.

Key driver for this technology choice is the ability to realize an infrastructure that is ready to implement diagnostics/advanced diagnostics and asset management capabilities and to enable predictive maintenance. Guidelines provided in this

document are intended to design the fieldbus based system with minimum risks and no errors.

4.2. Overall System Configuration

4.2.1. General

A fieldbus system refers to a control system that uses a digital, two-way, multi-drop communication link among intelligent measurement and control devices. It serves as a Local Area Network (LAN) for advanced process control, remote I/O and high-speed factory automation applications. With the DCS system, it is possible to build a fieldbus system according to the Engineering Standard, and to operate and monitor the function blocks of the FF devices in the same manner as for the function blocks of the controllers. By mounting a DCS FF communication module (H1 controller) in the DCS controller, it is possible to integrate a fieldbus system in the following manner:

4.2.2. Integration of Control Function in DCS Controller

A FF function block is a part of the function block library of the DCS and can be expressed on a control drawing in the same manner as a function block of the DCS. For example, if a control loop is required to be configured with the fieldbus blocks, the loop will consist at least of a FF-AI, FF-PID, FF-AO as FF function blocks on the control drawing. This function, to distribute the control functionality into the field, is called "Control in the Field". The use of a combination of DCS internal function blocks and FF function blocks is also possible.

4.2.3. Integration of Operation and Monitoring

Fieldbus function blocks of FF devices can be operated and monitored through FF function blocks in the same way as function blocks of the DCS are operated and monitored.

Alarms sent out from the fieldbus blocks of FF devices are handled via FF function blocks in the same way as the alarms of DCS function blocks (such as process alarms and system alarms) through FF function blocks.

4.2.4. Integrated Engineering Function in DCS

An engineering function of the DCS provides both

- function block application builder and
- fieldbus function block application builder

as an integrated system function in order to integrate the fieldbus system functions, such as configuration of fieldbus H1 segments, registration of FF devices and control drawings containing FF function blocks.

In addition, an asset management function is provided. This function is not directly related to above engineering, operation and monitoring functions, but is a maintenance related function with long-term data storage capability. The asset management system will efficiently handle FF device management and maintenance works.

The asset management system also supports traditional analogue devices and HART devices and as such, provides integrated management of FF and HART de-

vices. If FF field devices are used HART communication for these devices typically is not required anymore.

5. Field system design guidelines

5.1. General

Foundation™ Fieldbus is an all-digital, serial, two-way communication protocol that interconnects devices in the field such as sensors, actuators, and controllers. FOUNDATION™ fieldbus has also the capability to distribute control applications across its network in the field. Furthermore it enables advanced diagnostics for all fieldbus components and asset management tools resulting in higher plant availability. A typical fieldbus installation provides connection from a network of field devices to a host system via a two way, serial communication link. The cabling and connections are arranged in a multi-drop fashion, requiring only a single pair wire with parallel connections to field devices. This is quite different from the traditional approach of connecting 4 to 20mA devices to a DCS system using dedicated pairs of wires for each device.

The wiring for a typical fieldbus application looks as follows:

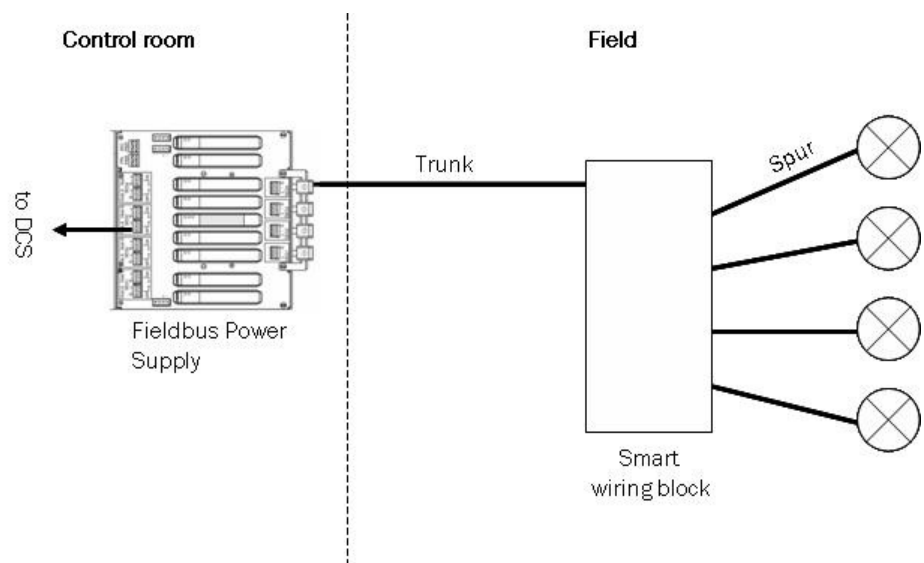

Figure 1: Fieldbus typical

Depending on the type of smart wiring blocks this general structure fits for both, safe area and hazardous area applications in Class I, Div 1 or Div 2.

A typical Fieldbus installation for a Class I, Div 2 application in acc. with High Power Trunk / non-incendive field wiring concept is as follows:

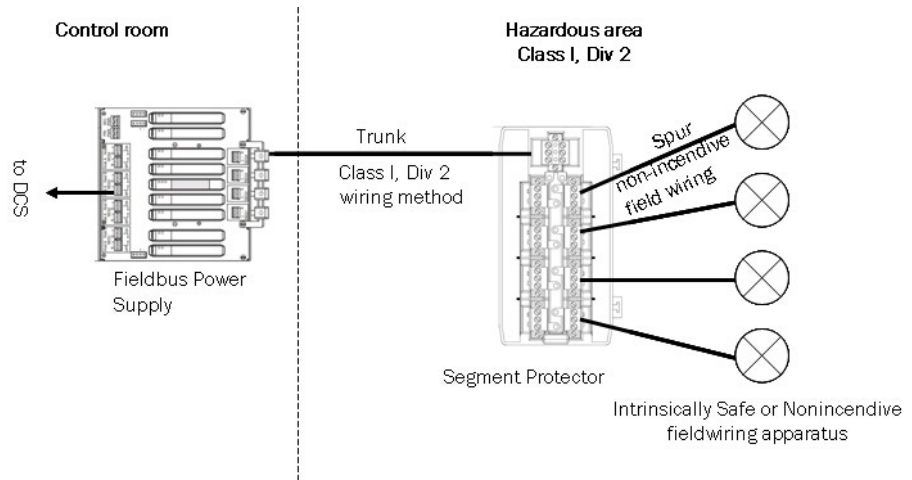

Figure 2: Fieldbus typical Class I, Div 2 application

A typical Fieldbus installation for a Class I, Div 1 application in acc. with High Power trunk / Ex ia IIC concept is as follows:

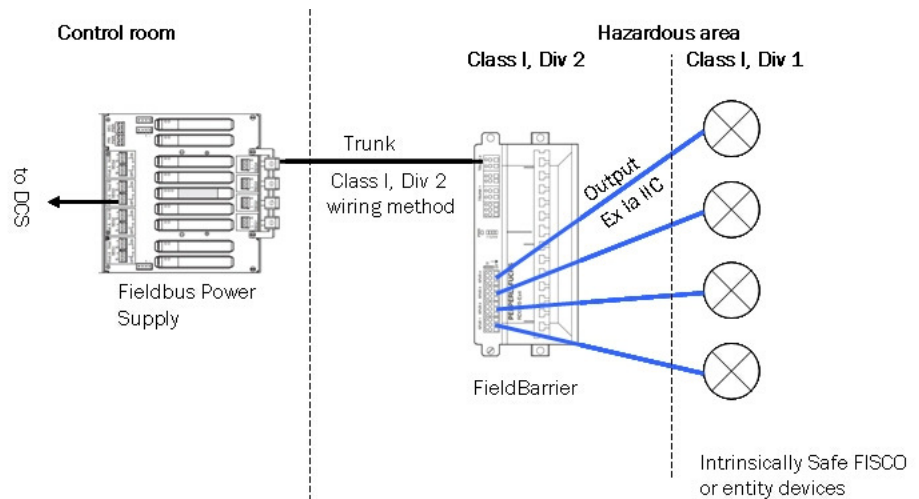

Figure 3: Fieldbus typical Class I, Div 1 application

Each fieldbus running from the host system to the field is known as a segment (see Figure 1: to Figure 3:). Each segment consists of a trunk or home-run, running from the host system (DCS) to the processing plant with parallel connected spurs linking to field devices such as transmitters and control valves. Smart wiring blocks with integrated short circuit protection are preferred to connect the trunk to the individual spurs.

A Fieldbus Power Supply connected to the trunk provides conditioned power to all devices on the fieldbus segment.

5.2. Fieldbus Application

The use of fieldbus shall be maximized for all regulatory process control devices where a suitable FF device is available and in addition, shall also apply to all

Packaged Equipment (except in those packages with their own PLC). The regulatory process control loops shall typically include the following:

- Monitoring loops.
- Temperature monitoring loops.
- Simple PID loops.
- Cascade loops.
- Sequence loops.
- Complex loops
- Discrete signals

Fieldbus shall not be used for the following applications:

- Emergency Shut Down System and Fire & Gas Detection System signals due to safety reasons.

5.3. Field Device Selection

5.3.1. Interoperability

The fieldbus devices have to be fully interoperable with the DCS, including maximizing of the associated advanced diagnostic features coupled to Asset Management System capabilities within DCS System.

To ensure full interoperability, all devices shall be supplied with the DD file and firmware revisions.

Based on the objectives above, the following selection method shall be applied for fieldbus devices excluding valve positioners (in order of preference):

- 1st Selection DCS FF devices.
- 2nd Selection Other FF devices.

Similarly, the selection method for valve positioners shall be as follows (in order of preference).

- 1st Selection XXXXXX valve positioner
- 2nd Selection DCS valve positioner

Any other FF device and /or positioner shall, as a minimum, have the following features available:

- FOUNDATION™ Fieldbus Certification as having passed the Interoperability Test Kit (ITK), revision 4.01 (or later) and are listed on the approved devices list maintained on the FF web site: www.fieldbus.org.
- The FF device shall be capable of performing continuous diagnostics, including self-test functions, to provide specific diagnostic information to the Asset Management System.

In addition a „sample“ device of each instrument type shall be submitted to DCS Supplier for interoperability testing with both the DCS and Asset Management System. On successful completion of these tests, the DCS vendor or EC shall provide the necessary approval for use and shall update the “Approved Device List-

ing” accordingly. DCS vendor will be responsible of getting all necessary data for the “Interoperability test” and coordinate the instrument vendors to complete successfully the test.

5.3.2. Fieldbus Function Blocks

The function blocks (FB) as defined by the FF are grouped into basic, advanced, flexible and SIS function blocks, but not all of these FB's are appropriate for use in field devices, and some are not available and/or do not have interoperability tests and/or are not required for this project.

For a project the function blocks should be defined as follows:

- Transmitter – AI for each required process variable.
- Positioners – AO
 - In case control in the field will be used - PID
- Eight Input Temperature Transmitters (EITT) - MAI

Any other control related FB's, please refer to chapter 5.3.5.

In addition, these devices will be specified and delivered to site with the following default parameter settings:

Parameter		Setting
Boot_Class		BASIC (for all FF devices)
STATUS_OPT (propagate Fault)		
	Monitoring Loop	AI Propagate Fault Forward: OFF
	Local Control Loop	AI Propagate Fault Forward: ON AO Propagate Fault Backward: ON
Pressure & Differential Pressure Transmitter		
	L_TYPE	Direct
	XD_SCALE	1 to 10 bar
	OUT_SCALE	0 to 5 m
Level Transmitters		
	L_TYPE	Indirect
	XD_SCALE	0 to 10 bar
	OUT_SCALE	0 to 5 m
Flow Transmitters		
	L_TYPE	Indirect SQRT
	XD_SCALE	High and low scale values of the transmitter
	OUT_SCALE	0 to 100 kg/h

Attention

The above shown table is only an example. All settings need to be defined depending on the process and the DCS functionality!

5.3.3. Field Device Management

The Physical Device (PD) Tag must be set prior to installation to enable connection of multiple devices during construction and commissioning. This shall be achieved either by the device manufacturer, prior to shipment, or the subcontractor prior to connection.

5.3.4. Field Device Power

FF devices should be powered from the segment. Bus-powered devices typically require 12 - 25mA of current at between 9 and 32 volts, but devices requiring more than 30mA shall be subject to approval.

Some FF devices are power polarity sensitive and therefore wiring polarity shall be maintained for all devices.

5.3.5. Link Master Devices

No FF device needs to be specified to have the Link Master capability. In case of redundancy is required, this shall be realized by a redundant H1 controller

5.3.6. Device Upgrading

FF devices use internal software of a certain revision. At present FF device software is quite often improved and upgraded, while the hardware is left unchanged.

To accommodate easy device upgrading, the devices shall, where available, be specified to have flash memory that can be on-line flashed with the latest device software (firmware).

Attention:

Some specific field devices are known as to require a supply current up to 42mA during firmware update via Fieldbus for a short time. The physical layer segment layout shall be defined in a way that such a firmware download via H1 does not influence the other communication running on this segment. Especially the energy limiting wiring blocks like Segment Protectors or FieldBarriers, splitting the trunk to spurs, are requested to support a minimum of 42mA as rated current.

Furthermore it is essential to record the applied device revision, DD and CFF revision.

5.4. Critical Loop definition and Application

The FOUNDATION™ Fieldbus End User Advisory Council (FF EUAC) has classified positioners into the following 3 criticality levels. Criticality level shall be shown on both the segment and loop drawings.

5.4.1. Level 1

Definition:

A failure of a Level 1 positioner will result in a total system trip, causing a shut-down of the entire unit, or other unavoidable losses in excess of \$10M. Normal positioner failure mode is to be used for this classification.

Design Requirements:

Level 1 positioners and their associated measurement device (transmitter) should reside on H1 networks that are only used for Level 1 control. The segment may have

- one (1) Level 1 positioner and associated transmitter when services are independent, or
- two (2) Level 1 positioners and associated transmitters when services are dependent. Dependent means that either of the two (2) positioner will shut down the same piece of equipment (example pass flows on a fired heater).

5.4.2. Level 2

Definition:

Failure of a Level 2 positioner will result in a total system trip, causing a shutdown of the entire unit, or other unavoidable losses in excess of \$100K. However, the Level 2 positioners' process dynamics allow time for quick recovery from the failure, either by quickly fixing a fault or by taking manual control. The material and energy capacity of associated vessels, geographic location, and elevation/accessibility of such positioners should be considered. The difference in Level 1 and 2 valves are dependent on operations ability to respond to a single failure.

Design requirements:

Level 2 positioners and their associated measurement device (transmitter) should reside on H1 networks/segments that are only used for control. The segment may have

- one Level 2 valve and associated transmitter when services are independent, or
- two Level 2 valves or a Level 2 and
- a Level 3 valve and associated transmitters when services are dependent.

Dependent means that either of the two valves will shut down the same piece of equipment (example pass flows on a fired heater).

To aid in assurance of interoperability, consideration may be given to having the Level 2 field devices in the loop supplied by a single vendor. Host interface cards and field devices for all Level 2 loops shall be independently tested for interoperability. The devices and interface cards shall be kept at compatible revision levels for the lifetime of the network. Upgrades should be done during plant turn-arounds if necessary.

The network/segment drawing should show the criticality rating and shall prominently display that no additional devices shall be loaded on this network/segment.

5.4.3. Level 3

Definition:

Failure of this Positioner will not result in any short-term risk of total unit shutdown or major operating losses. Level 3 valves can go to their fail position without requiring immediate operator action.

Design Requirements:

Level 3 positioners can reside on cards or networks/segments with up to three other level 3 valves, or on a segment with a level 2 valve (see 5.4.2 for other limitations on the number of valves on a segment). Networks containing Level 3 control contain products from multiple (approved) vendors including measurement only devices.

Consideration should be given to the impact of common mode failures among level 3 and 2 & 3 positioners on the same segment and in addition, regulatory

control loop associated with „spared“ vital and essential equipment should be allocated on different segments.

Note that the number of control and critical loops per segment is given on the basis of loop criticality rather than associated FF limits.

5.5. Control Assignment

For a project, all control related functions shall be carried out in the DCS rather than the field.

However, where desired, the contractor shall be responsible to assign control function to reside within the respective FF devices.

5.6. Segment Grouping

In order to fully explore the benefits from FF technology, grouping all devices of a particular loop within one segment is desired.

However, in order to minimize the effect of Fieldbus implementation, this grouping/assignment is not a mandatory requirement, but shall be followed where possible, without incurring excessive cable run lengths.

5.7. Temperature Transmitters (Multiple type)

FF Eight Input Temperature Transmitters (EITT) may be used where high density temperature measurements are required for DCS indication, including rotating machinery bearing temperature measurements. Two different methods of segment design may be implemented.

Where additional monitoring devices can be connected to a segment, as defined in chapter 5.4, the quantity of EITT shall be limited to three per segment. The following considerations must be taken into account:

Communication of the temperature signals from the EITT FB will be performed during the scheduled communication period of the macrocycle and a maximum delay between a change in measured variable and when that change is displayed at the HIS needs to be defined. It must be ensured that this delay is acceptable for the particular process application.

One segment can be used for temperature transmitters only; in this case 5 EITT's may be connected to one segment, leaving one spare way for future use.

5.8. Required macrocycle times

The macrocycle times needs to be defined. Up to 70% of the macrocycle time could be used for scheduled data transmission and minimum 30% of the macrocycle time should be free for unscheduled communication.

The required macrocycle times depends on

- the process
- type of loop
- the following differentiation between type of loops is recommended:

- control loops, with no more than 3 control loops per segment and no more than 3 EITT.
- monitoring loops
- Temperature monitoring loops, with no more than 5 EITT per segment.

The macrocycle times could be different for the different types of loops.

5.9. Hazardous Area Classification

Attention:

The following paragraph describes the requirements when the hazardous area is classified in acc. with NEC 500.5 (classes and divisions). In case classification shall be done in acc. with NEC 505.5 (Zones) please refer to the document "Specification Proposal for FOUNDATION™ Fieldbus based on international and European standards".

Hazardous area protection depends on the application and shall be as follows:

Class I, Division 1

- Intrinsic Safety shall be the preferred explosion protection method for a Class I, Div 1 application. The field device shall be marked accordingly, e.g. for use in Class I, Div 1 Group A, B, C, D or EEx ia IIC (Temperature class must be defined).
- As a secondary solution when Intrinsic Safety is not possible, other explosion protection methods are acceptable, e.g. explosion proof apparatus, purged- or pressurized systems.

Class I, Division 2

- Nonincendive Field Wiring shall be the preferred explosion protection method for a Class I, Div 2 application. The field device shall be marked accordingly, e.g.
 - for use in Class I, Div 2 Group A, B, C, D (or better)
 - Ex ic (or better). Temperature class must be defined
 - Ex nL (or better). Temperature class must be defined.

Attention:

For more details regarding Ex nL and Ex ic please refer to the document "Specification Proposal for FOUNDATION™ Fieldbus based on international and European standards".

Intrinsic safety, non-incendive field wiring and energy limitation (Ex nL) are the only explosion protection methods which allow live maintenance without any additional organizational measures or mechanical explosion protection methods.

IS devices shall be used for Class I, Div 1 application. Non-incendive field wiring, energy limited or IS devices shall be used for Class I, Div 2 application. All devices shall be certified and labeled for the required area classification where they will be installed.

The IS devices shall conform to the FOUNDATION™ fieldbus profile

- type 511 or type 512 (FISCO) and/or
- type 111, type 112, type 121 or type 122 (Entity)

5.10. Redundancy

If redundancy is required to enhance the overall availability the following redundant equipment shall be incorporated within the host system, DCS, EC:

- Redundant DCS Bulk Power Supplies with 30-minute battery backup (UPS).
- Redundant DCS System Controller Power Supplies.
- Redundant DCS System Controllers.
- Redundant FF H1 Cards as preferred option (not mandatory).
- Redundant FF Power Supplies / Power Conditioners serving 1 segment per pair of Power Supplies/Power Conditioners as a preferred option.

Additionally at least segments which contain level 1 loops shall be monitored continuously by an advanced physical layer diagnostic module.

5.11. Physical Device Loading Requirements on H1 Bus

5.11.1. General Requirements

FOUNDATION™ Fieldbus H1 bus supports theoretically up to 32 devices per segment. This includes the H1 controller(s). The field devices should be fed from the fieldbus cable. Only in case the required field device functionality is not available in a fieldbus powered version externally fed field devices shall be accepted.

There could be some limitations which have to be observed:

- DCS related limitations
- Physical layer related limitations

5.11.1.1. DCS related limitations

The DCS/H1 controller could limit

- the no. of addressable nodes
- the no. of Function Blocks which could be handled
- the no. of VCR which could be handled

These limitations have to be observed.

5.11.1.2. Physical Layer related limitations

Field devices should be supplied from the fieldbus cable. The average current, drawn by field devices connected to the same segment is, depending of the type of field devices, between 20mA and 25mA per field device.

Depending on the limitations explained in chapter 5.11.1.1 there will be connected not more than 16 field devices per segment (including required spare). This results in up to 400 mA of total supply current required by the field devices. Additionally wiring blocks with short circuit protection require current from the fieldbus cable. To avoid any additional limitations just in case of a short circuit or long cable runs the Fieldbus Power Supply shall support a supply current of at least 500 mA.

Only in case it is ensured that the required supply current per segment is less or equal to 350mA (including required spare) Fieldbus Power Supplies with a supply current of 360mA are acceptable.

5.11.2. Requirements for Non-Ex Application

To avoid a breakdown of a segment in case of a short on the spur or field device level the wiring blocks shall support short circuit protection (Segment Protectors). The Segment Protectors shall support a supply current of at least 42mA per channel, as explained in chapter 5.3.6 and the short circuit current shall be limited to no more than 60mA.

5.11.3. Requirements for Class I, Div 2 application

To avoid limitations in the no. of connectable field devices standard Fieldbus Power Supplies with a minimum supply current of 500 mA (360 mA) shall be used. For the installation of the trunk cable a Class I, Div 2 wiring method in acc. with NEC 501.4 (B) shall be used..

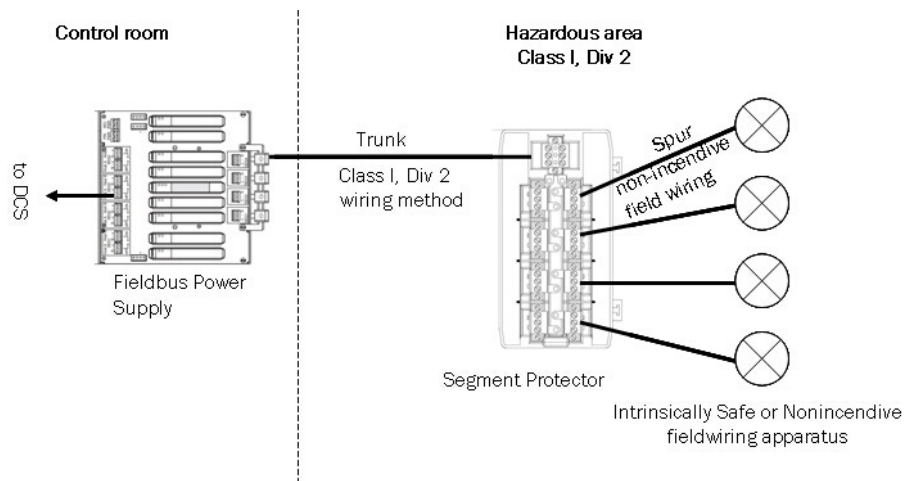

Figure 4: Structure High Power Trunk concept for Zone 2

To allow a simple live maintenance capability the field devices shall be certified for Nonincendive field wiring, EEx nL or EEx i. In case of an EEx i certified field device the field devices shall comply with the FOUNDATION™ fieldbus profile type 111, type 112, type 121 or type 122.

The Segment Protectors shall be certified for Nonincendive field wiring, Ex nA [nL] or Ex nA [ic]. The requirements given in chapter 5.11.2 are also valid for Class I, Div 2 application.

5.11.4. Requirements for Class I, Div 1 application

Today there are available two solutions for Class I, Div 1 application:

- Full FISCO solution
- High Power Trunk Concept

The following pictures show the structures of both solutions:

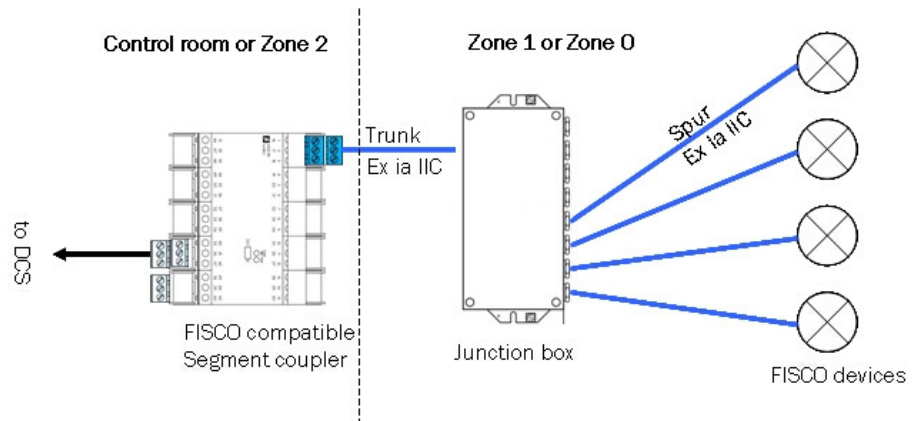

Figure 5: Structure full FISCO system

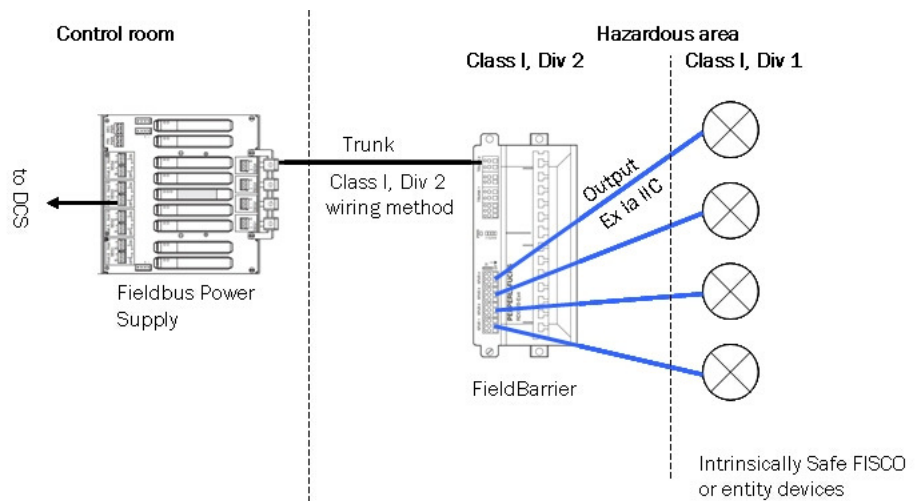

Figure 6: Structure High Power Trunk concept for Class I, Div 1

The typical supply current of FISCO compatible Fieldbus Power Supplies (EEx ia IIC) is 100mA. The typical supply voltage of these components is 12.8 Vdc. These limitations causes that

- the number of connectable field devices per segment is reduced (depending on the real current consumption of the field devices down to 4 to 8). This would require more Fieldbus Power Supplies compared to the High Power Trunk concept
- the max. cable length is reduced. This depends on the low supply voltage of a FISCO power supply
- typically short circuit protection for the spurs is not supported. The reason is that the wiring blocks with short circuit protection causes an additional voltage drop which reduces the max. cable length additionally.

In practice and in order to minimize the Fieldbus validation and commissioning related problems, High Power trunk concept with FieldBarriers shall be used. FieldBarriers will be powered via standard Fieldbus Power Supplies. The trunk needs to be installed in accordance with NEC 501.4 (B) “Class I, Div 2 wiring methods”.

The FieldBarrier works as an IS barrier. The outputs of this barrier shall be [Ex ia] IIC certified. This will at least allow live maintenance on the field device level.

To avoid any additional limitations the FieldBarrier outputs shall be certified in acc. to FISCO **and** Entity. The outputs shall be short circuit limited with a short circuit current no more than 50mA.

Additional it is recommended that the FieldBarrier is DIN rail mountable. Then it could be easily mounted in any project specific enclosure.

5.12. Fieldbus Power Supply Requirements

To avoid any additional limitation the FPS shall support as much output voltage as possible. FF field devices are working within the voltage range from 9 Vdc ... 32 Vdc.

Typical FPS's are offering a supply voltage of 28 Vdc at 500 mA supply current. In case it is ensured, that the required

- supply voltage is less than 25 Vdc (including required spare)
- supply current is less than 350 mA (including required spare)

Fieldbus Power Supplies with a supply voltage of 25 Vdc at 360 mA may be accepted

5.12.1. Additional Fieldbus Power Supply Requirements

The FPS shall support physical layer diagnostic. Depending on the application requirements it could be differentiated between

- Basic diagnostic
- Advanced diagnostic.

Basic Diagnostic

Basic diagnostics shall support one alarm relay contact which indicates

- too high trunk current
- too low trunk voltage
- faulty power supply module (especially in case of a redundant power supply)
- too low input voltage from bulk power supply

Advanced Diagnostic

Advanced diagnostics can be used during

- commissioning to ensure that the physical layer offers the best possible physical layer values during start up. Additionally it offers the capability to detect physical layer problems at a very early point and it allows to solve the networking problems before starting production.
- operation to receive warning or alarm messages before a segment fails to operate
- troubleshooting to pinpoint the problem area.

The Advanced Diagnostic Module must be an integral part of the motherboard hosting the Fieldbus Power Supplies. It shall imply all basic diagnostic functional-

ities and shall furthermore offer the following additional information to guarantee highest availability of Fieldbus communication by monitoring:

- Amplitude of the communication signal which is an indication for
 - termination faults
 - too high wave attenuation depending on changed cable parameters, corroded terminals, ...
- Noise
- Balance to ground. If the system is unbalanced the sensitivity to noise is increased.
- Jitter. Fieldbus is using a rectangular signal for data transmission (Manchester II coding). A fieldbus node is expecting an edge in the middle of the bit time. The polarity of the edge is indicating the logical status "0" or "1". The edge should cross the supply voltage level exactly in the middle of the bit time. Depending on existing inductances and capacitances there will be a deviation from this ideal crossing point. This deviation is called Jitter. A fieldbus node is not measuring the signal itself; it opens a time window (at least $\pm 3.2 \mu\text{s}$) around the ideal crossing point and check the edge for their polarity only. In case the Jitter is too high the edge will cross the supply voltage level outside of the measurement window. This causes that this bit gets lost. Depending on this the complete telegram will be detected as wrong and therefore rejected. This causes a loss of this telegram within this macro cycle.
Nearly all possible faults on a fieldbus segment will influence the jitter and therefore this is one of the most important measures.

These values shall be measured for the system and, except balance, for each connected node address.

The Advanced diagnostic module shall support the following functionalities:

- Commissioning wizard to ensure a fast and secure checkout of the segments. Additionally this wizard shall support an automatic report generation.
- Diagnostic function, which leads the maintenance personnel to the problem area. For this functionality it is required that the diagnostic module interprets the combination of changed physical layer values.
- History function to have the capability to detect long term changes in the physical layer values.
- Oscilloscope to measure the signal form. The oscilloscope shall support fieldbus specific trigger events.

Because the required bandwidth for fully featured advanced diagnostics solution cannot be covered by transmitting the diagnostic data via the Fieldbus itself, the data shall be transmitted via a separate diagnostic bus (e.g. RS485 or Ethernet).

5.13. Segment Spare Philosophy Requirements

The total number of devices per segment will not exceed 16 as explained in chapter 5.11.1.2. However, to include for the 25% pre-wired spare capacity, the maximum number of devices shall be 12 per segment.

5.13.1. Segment Execution Time Requirements

5.13.1.1. Segments Used for Regulatory Control and Monitoring

For all segments a macrocycle time needs to be defined. The idle time for unscheduled services shall be at least 30%. The following list is showing an example:

- Macrocycle Time - 1000 msec.
- Scheduled Communication Time - 700 msec.
- Unscheduled Communication Time - 300 msec.

The following is the maximum allowable execution/communication time for each FB to ensure that with maximum loop segment loading, the above defined times will be reached:

Communication Time between

- FF Card and FB - Maximum 40msec
- Execution Time for AI FB - Maximum 100msec
- Execution Time for AO FB - Maximum 130msec
- Execution Time for PID FB - Maximum 160msec

Any deviation to the above will require additional validation and shall be subject to EC approval.

5.13.1.2. Segments Used For Temperature Multi Input Devices

For all segments dedicated to EITT use a macrocycle time needs to be defined with an idle time of more than 30% and as such, the following definitions shall apply for a project:

- Macrocycle Time - needs to be defined
- Scheduled Communication Time - 40msec
- Scheduled Communication Time for signal update < 70% of macro cycle time
- Unscheduled Communication Time - > 30% of macro cycle time

The function block execution time is still scheduled by the LAS and the maximum allowable execution time for the EITT FB to ensure that with maximum loop segment loading, the above times shall not be exceeded:

- Execution Time for EITT FB - Maximum 40msec

Any deviation to the above will require additional validation and shall be subject to EC approval.

5.14. Segment Wiring Design Requirements

5.14.1. Overall Wiring Design Philosophy

Fieldbus implementation shall mimic the traditional implementation method as follows:

- The trunk cable shall be

- either a Multicore cable where each pair of cable is individually screened with the 1st pair used for the 1st H1 segment and the 2nd pair for the 2nd H1 segment and so on. Additionally an overall screen is required. (The max. number of segments per multicore cable needs to be defined).
- or a single pair screened trunk cable.
- The field junction box shall accommodate no more than two H1 segments with each accommodating up to 16 FF devices as detail in chapter 5.11.1.2.
- Each FF device shall be connected to the Fieldbus junction box via a single pair screened spur cable.

Any deviation from the above shall be subject to approval by EC.

5.14.2. Topology

The Chicken-Foot or Tree topology consists of a Fieldbus segment connected to a common JB via the trunk cable from the marshalling cabinet as detailed in Figure 7: below:

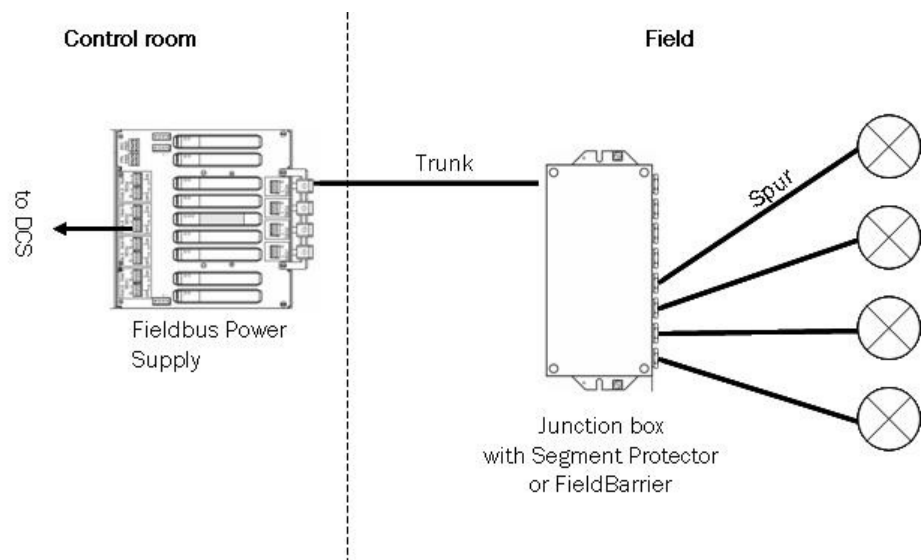

Figure 7: Typical fieldbus topology

Any deviation from the above shall be subject to approval by EC.

5.14.3. Cable Type

The same cable type could be used to wire the trunk and the spurs. The recommended cable type is cable type A as defined in chapter 12.8.2 of IEC 61158-2 Ed. 3.0.

Cable characteristics

The main characteristics are:

- One pair insulated, overall screen and PVC sheath or a multicore cable with PVC sheath and an individual screen for each pair of leads plus an overall screen.

- Cross section: AWG 18 (0.8 mm²) for standard application. For special application AWG 16 (1.0 mm²) or AWG 15 (1.5 mm²) could also be used.
- Lead resistance: 44 ohm/km per loop at 68 °F (20 °C) for standard application. For special application 36 ohm/km or 24 ohm/km per loop at 68 °F (20 °C) could also be used.
- Max capacitance: 200 nF/km
- Max. capacitive unbalance of 4nF/km
- Max inductance: 1 mH/km
- Attenuation: 3 db/km
- Impedance 100Ω ±20%

The segment design will be based on default values. If these values are exceeded further attention and/or validation of the segment design will be required.

5.14.4. Cable Length

According to the Physical Layer specification (IEC 61158-2 Ed. 3.0) the maximum allowed overall cable length of a fieldbus segment is limited to 6230 ft (1900 meters). This total segment length is computed by adding the length of the main trunk line and all the spurs that extend from it.

- Total Segment Length = Trunk + \sum All Spurs

The total segment length is limited by voltage drop and signal quality (i.e. attenuation and distortion).

In order to eliminate the need to calculate the physical loading of each segment and to reduce the validation requirement, project specific limits for

- max. trunk cable length
- max spur cable length

needs to be defined and validated for the highest available ambient temperature. As validation tool the software Segmentchecker from Pepperl+Fuchs could be used. This software could be downloaded free of charge from the web site: www.segmentchecker.com

The following values are an example for these limits:

- Trunk cable length < 1640 ft (500 meters).
- Spur cable length < 196 ft (60 meters).

Any deviation from the defined cable lengths shall be subject to EC.

5.14.5. Power Consumption

A typical layout for monitoring loops is 12 field devices per segment + 25% spare. In case the max. current consumption of a field device is 25mA the required supply current is 300 mA + 25% spare. This is equal to 375mA. Additionally the Segment Protectors require current from the Fieldbus cable.

Therefore the maximum segment current shall be limited to 500mA. This includes the current consumption of all connected field devices and Segment Protectors or FieldBarriers.

The maximum current required by a single FF device shall not exceed 25mA.

5.14.6. Minimum Operating Voltage

Field devices are working in the supply voltage range from 9 Vdc to 32 Vdc as defined in the IEC 61158-2. The minimum supply voltage at the FF device shall be 9.9 Vdc at highest ambient temperature, which includes a 10% safety margin.

5.14.7. Attenuation

FF operates at a frequency of 39 kHz where a standard FF cable has an attenuation of 3 dB/Km at 39 kHz or about 70% of the original signal after 3280 ft (1 km).

A Fieldbus “transmitter” can have a signal as low as 0.75 volts peak-to-peak and a Fieldbus “receiver” must be able to detect a signal as little as 0.15 volts peak-to-peak.

Based on a 3 dB/km attenuation, the fieldbus signals can be attenuated by 14 dB. This normally does not provide a problem for fieldbus installation especially based on the cable limits detailed above.

5.14.8. Example Calculation

5.14.8.1. Non-Ex and Class I, Div 2 Application

In this example, made for Safe area and Zone 2 application, the following default values are specified:

- FPS $U_{out} > 28$ Vdc @ 500 mA
- max. no. of field devices per segment = 16 (incl. spare)
- max. Trunk length = 2300 ft (700 m).
- max. spur length = 196 ft (60 m)
- max. ambient temperature 122 °F (50 °C)
- cable type A with AWG 18 (0.8mm²) cross section
- max. current consumption per field device 25 mA

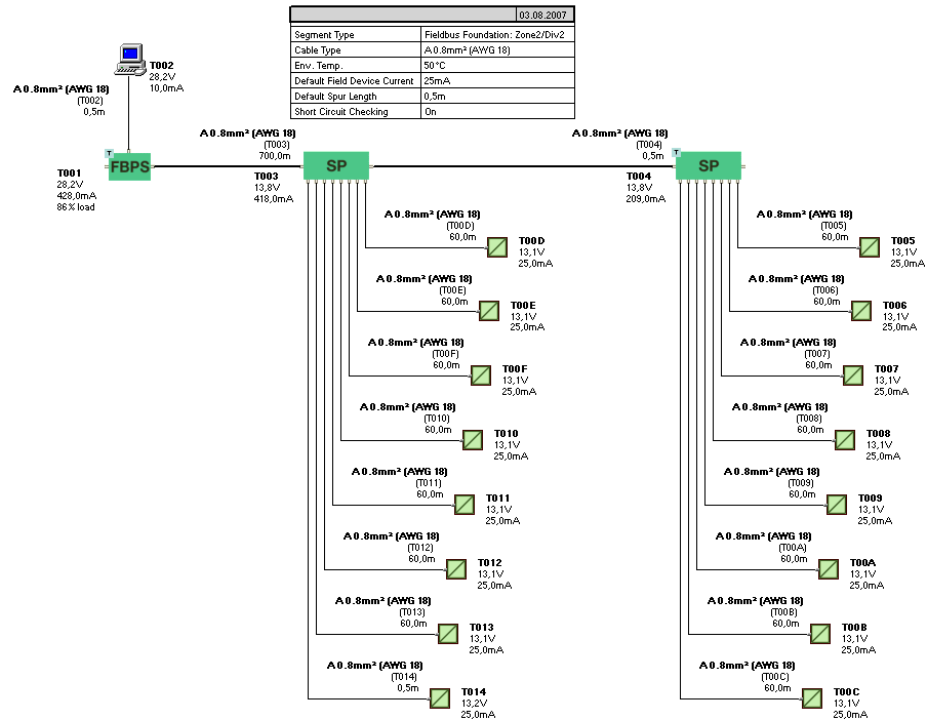

Figure 8: Calculation example for Safe Area and Class I, Div 2 application

The example shows that, under the above specified preconditions, there will be no physical layer problems available.

5.14.8.2. Class I, Div 1 Application

In this example, made for Class I, Div 1 application, the following default values are specified:

- FPS $U_{out} > 28V_{dc}$ @ 500 mA
- max. no. of field devices per segment = 16 (incl. spare)
- max. Trunk length = 1640 ft (500 m).
- max. spur length = 196 ft (60 m)
- max. ambient temperature 122 °F (50 °C)
- cable type A with AWG 15 (1.5mm²) cross section
- max. current consumption per field device 25mA

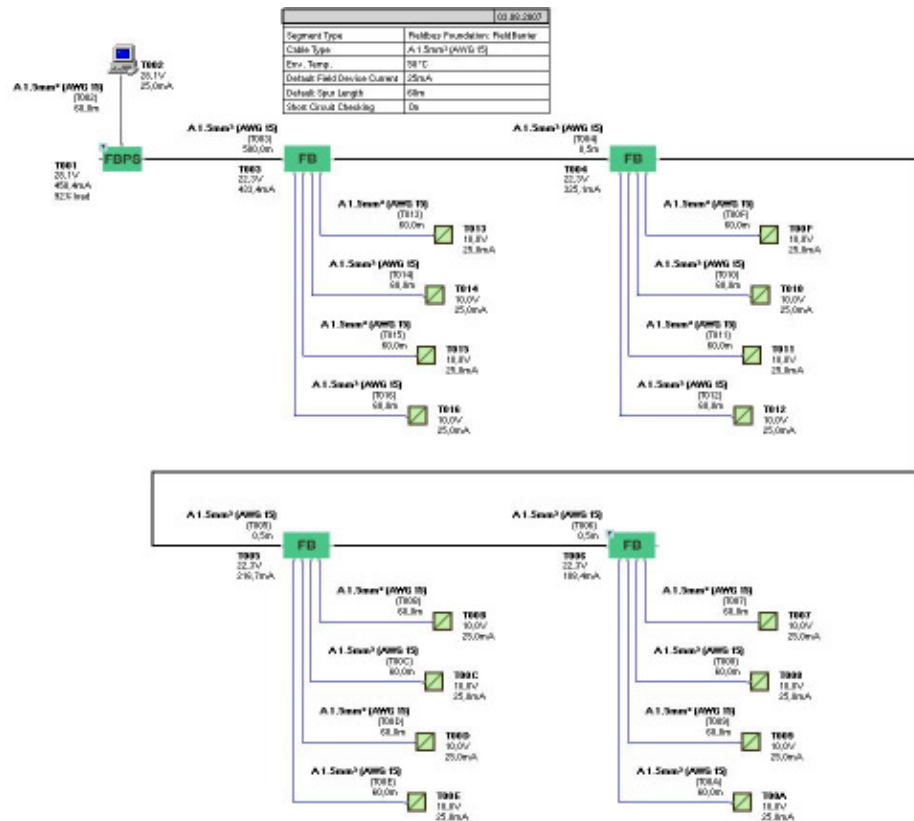

Figure 9: Calculation example for Zone 1 application

The example shows that under the above specified preconditions the installation will have no physical layer problem.

5.14.9. Segment Design Validation Tool

After defining default values as explained above it is required to validate a segment only in case of these values will be exceeded.

These validations could be done by the Segmentchecker software of Pepperl+Fuchs (see: www.segmentchecker.com)

5.14.10. Enclosure Requirements

The wiring blocks shall be mounted inside an enclosure to reach the required IP protection degree (e.g. IP 65).

Such a Fieldbus junction box shall be adequately sized, e.g. to contain

- two Fieldbus segments with up to 16 spur connections each.
- additional terminals (if required)
- surge protectors (if required)
- an additional earth bar to realize the specified grounding method (if required).

The Fieldbus junction box shall follow the same principle and standards as for traditional junction boxes. In case the Junction Box includes 2 Fieldbus segments

it shall include 2 rows of wiring blocks (Segment Protectors or FieldBarriers), one for each segment.

5.14.11. Wiring Block Requirements

Each wiring block shall be specifically made for FF networks.

Depending on the different approach it must be differentiated between wiring blocks for safe area or Class I, Div 2 application and wiring blocks for Class I, Div 1 application.

5.14.11.1. Wiring Block Requirements for Safe area and Class I, Div 2 Application

The wiring blocks for safe area and Class I, Div 2 application shall fulfill the following minimum requirements:

- Shall have a T-connector for 2 dedicated connections for the fieldbus trunk cable.
- 4, 6, 8, 10 or 12 spur connections.
- The wiring blocks shall be delivered with an externally mounted, but removable, redundant fieldbus terminator.
 - The fieldbus terminator shall be mounted at the outgoing trunk cable connection. Just in case this trunk connection is used to extend the trunk by another wiring block the fieldbus terminator has to be removed and the free contacts can be used for the interconnection to the next wiring block. Since the next wiring block has the same type of terminator mounted a proper termination of the fieldbus is guaranteed always.
 - At least the capacitors of the fieldbus terminators shall be redundant. In case one capacitor fails this will not cause a loss of the terminator and therefore will cause no loss in communication. This failure could be easily detected by an Advanced Diagnostic Module
- Dedicated grounding termination points will be provided to ground the individual cable screens for each cable (trunk and spur).
- Short circuit current shall be limited to 60 mA per input.
- Rated current of at least 42 mA
- Wire capacity: AWG 12 – 24 (0.5 mm² to 2.5 mm²)
- Temperature range -58 °F to 158 °F (-50 °C to +70 °C).
- DIN rail mounting.
- Hook up possibility at all terminals for a mobile Advanced Diagnostic Module to have an easy capability for measurements in the field.
- Integrated over voltage protection

5.14.11.2. Wiring Block Requirements for Class I, Div 1 Application

The wiring blocks for hazardous area application in Class I, Div 1 shall fulfill the following minimum requirements:

- 2 dedicated connections for the fieldbus trunk cable, Trunk in and Trunk out
- 4 output connections
- Galvanic isolation between the trunk and the outputs
- Integrated, switchable fieldbus terminator
- The outputs shall be certified in acc. with

- FISCO for the use of FOUNDATION™ Fieldbus devices profile type 511 and/or 512 or
- Entity for the use of FOUNDATION™ Fieldbus devices profile type 111, 112, 121 or 122.
- Dedicated grounding termination points shall be provided to ground the individual cable screens for each cable (trunk and spur).
- Short circuit current shall be limited to 50 mA per output.
- Wire capacity: AWG 12 - -24 (0.5 mm² to 2.5 mm²).
- Temperature range -58 °F to 158 °F (-50 °C to +70 °C).
- DIN rail mounting.

5.14.12. Grounding of Screens

Fieldbus is using a voltage difference signal for data transmission. Grounding of one signal lead would cause an unbalance which keeps fieldbus much more sensitive against external noise. Under worst case conditions grounding of a signal lead could cause a loss of communication.

No signal lead shall be grounded.

The shield of the fieldbus cable shall be connected to ground at the host or Fieldbus Power Supply end of the segment in the marshalling cabinet.

The type of grounding at the Junction Boxes and field devices needs to be defined. There are several possibilities available:

- no grounding (floating shield in the field) which is the preferred technology in the United States.
- capacitive grounding
- hard grounding

The type of grounding in the field depends on

- DCS requirements
- national laws and standards (especially in hazardous area application)
- required degree of EMC protection

The Segment Protectors and FieldBarriers shall be prepared for all types of grounding.

5.14.13. EMC protection

Grounding of the screens is one part to achieve the required EMC protection level. Especially the fieldbus power supplies and the wiring blocks shall comply with the following standards and reach the highest available category of protection, defined in the following table:

IEC Standard	Category
ESD IEC 6100 - 4 - 2	Category A
Radiated RF Immunity IEC 6100 - 4 - 3	Category A

IEC Standard	Category
Burst IEC 6100 - 4 - 4	Category A
Surge IEC 6100 - 4 - 5	Category B ¹
Conducted RF Immunity IEC 6100 - 4 - 6	Category A

¹ Conducting surge tests under Class A conditions would usually destroy the test system. This is why in general Class A compliance is not available on the market for surge immunity.