

# VisuNet GMP DM Hardware Manual

Manual



---

With regard to the supply of products, the current issue of the following document is applicable:  
The General Terms of Delivery for Products and Services of the Electrical Industry, published  
by the Central Association of the Electrical Industry (Zentralverband Elektrotechnik und Elek-  
troindustrie (ZVEI) e.V.) in its most recent version as well as the supplementary clause:  
"Expanded reservation of proprietorship"

**Worldwide**

Pepperl+Fuchs Group  
Lilienthalstr. 200  
68307 Mannheim  
Germany  
Phone: +49 621 776 - 0  
E-mail: [info@de.pepperl-fuchs.com](mailto:info@de.pepperl-fuchs.com)

**North American Headquarters**

Pepperl+Fuchs Inc.  
1600 Enterprise Parkway  
Twinsburg, Ohio 44087  
USA  
Phone: +1 330 425-3555  
E-mail: [sales@us.pepperl-fuchs.com](mailto:sales@us.pepperl-fuchs.com)

**Asia Headquarters**

Pepperl+Fuchs Pte. Ltd.  
P+F Building  
18 Ayer Rajah Crescent  
Singapore 139942  
Phone: +65 6779-9091  
E-mail: [sales@sg.pepperl-fuchs.com](mailto:sales@sg.pepperl-fuchs.com)  
<https://www.pepperl-fuchs.com>

<b>1</b>	<b>Safety</b> .....	<b>5</b>
1.1	Validity .....	5
1.2	Symbols Used .....	5
1.3	System Operator and Personnel .....	5
1.4	Pertinent Laws, Standards, Directives, and further Documentation .....	6
1.5	Intended use .....	6
1.6	Installation and commissioning .....	6
<b>2</b>	<b>Product Specifications</b> .....	<b>7</b>
2.1	Overview .....	7
2.2	Technical Data .....	9
2.3	Dimensions VisuNet GMP DM series .....	10
2.4	Interfaces and connectionsVisuNet GMP DM .....	11
2.4.1	VGA interface .....	11
2.4.2	Supply Voltage 24 V .....	12
2.4.3	Supply voltage 12 V (PA version) .....	12
2.5	Accessories .....	12
2.5.1	Keyboards .....	13
2.5.2	Pedestals .....	14
2.5.3	Wall arm versions .....	15
2.5.4	Wall bracket .....	16
2.5.5	Hole pattern of the mounting versions .....	16
2.5.6	Power supply accessories .....	17
<b>3</b>	<b>Installation and Commissioning</b> .....	<b>18</b>
3.1	Preparation .....	18
3.2	Mounting in the field .....	18
3.2.1	Grounding at pedestal and wall arm .....	19
3.3	Commissioning VisuNet GMP RM/PC .....	20
<b>4</b>	<b>Operation</b> .....	<b>21</b>
4.1	On Screen Display .....	21
4.1.1	Audio menu .....	23
4.1.2	Bright-Contrast menu .....	24
4.1.3	Menu Color .....	25
4.1.4	Image menu .....	27
4.1.5	Tools menu .....	28
4.1.6	Input menu .....	29
4.1.7	Exit menu .....	30
<b>5</b>	<b>Maintenance</b> .....	<b>31</b>
<b>6</b>	<b>Appendix</b> .....	<b>32</b>

219365 2023-07

<b>6.1</b>	<b>Chemical resistance of keyboard foil .....</b>	<b>32</b>
<b>6.2</b>	<b>Chemical resistances of the touch screen.....</b>	<b>32</b>
<b>6.3</b>	<b>Cofigurator VisuNet GMP DM .....</b>	<b>35</b>

# 1 Safety

## 1.1 Validity

The chapter “Safety” is valid as instruction manual.

Specific processes and instructions in this instruction manual require special provisions to guarantee the safety of the operating personnel.

## 1.2 Symbols Used

This document contains symbols for the identification of warning messages and of informative messages.

### Warning Messages

You will find warning messages, whenever dangers may arise from your actions. It is mandatory that you observe these warning messages for your personal safety and in order to avoid property damage.

Depending on the risk level, the warning messages are displayed in descending order as follows:



---

#### **Danger!**

This symbol indicates an imminent danger.

Non-observance will result in personal injury or death.

---



---

#### **Warning!**

This symbol indicates a possible fault or danger.

Non-observance may cause personal injury or serious property damage.

---



---

#### **Caution!**

This symbol indicates a possible fault.

Non-observance could interrupt the device and any connected systems and plants, or result in their complete failure.

---

### Informative Symbols



---

#### **Note**

This symbol brings important information to your attention.

---



---

#### **Action**

1. This symbol indicates a paragraph with instructions. You are prompted to perform an action or a sequence of actions.

## 1.3 System Operator and Personnel

Responsibility for planning, assembly, commissioning, operation, maintenance, and dismantling lies with the plant operator.

The personnel must be appropriately trained and qualified in order to carry out mounting, installation, commissioning, operation, maintenance, and dismantling of the device. The trained and qualified personnel must have read and understood the instruction manual.

## 1.4 Pertinent Laws, Standards, Directives, and further Documentation

Observe directives, standards, and national laws applicable to the intended use and the operating location. Observe Directive 1999/92/EC in relation to hazardous areas.

The corresponding datasheets, manuals, declarations of conformity, EU-type examination certificates, certificates, and control drawings if applicable (see datasheet) are an integral part of this document. You can find this information under [www.pepperl-fuchs.com](http://www.pepperl-fuchs.com).

Due to constant revisions, documentation is subject to permanent change. Please refer only to the most up-to-date version, which can be found under [www.pepperl-fuchs.com](http://www.pepperl-fuchs.com).

## 1.5 Intended use

The device is only approved for appropriate and intended use. Ignoring these instructions will void any warranty and absolve the manufacturer from any liability.

The device must not be repaired, changed, or manipulated. In case of failure, always replace the device with an original device.

## 1.6 Installation and commissioning

The device must only be operated in the specified ambient temperature range and at the specified relative humidity without condensation.

### Use shielded cable

To connect interfaces only use shielded cable.

### Screwing/locking connectors

To advance the cable shield screw/lock the connectors.

The device must be disconnected from the power supply prior to installation and maintenance. The power supply may be activated only after all the circuits required for operation have been fully assembled and connected.

### Leading of data cables and power circuit lines

Lead data cable and power circuit line in separate cable channels.

### Check cables and connectors

Before commissioning the system check all cables and connectors.

## 2 Product Specifications

### 2.1 Overview

GMP (“Good Manufacturing Practice”) is a set of guidelines for assuring the quality of production processes in controlled industries and closely follow the guidelines issued by the European Commission or the FDA in the US. GMP applications are typically used in the pharmaceutical and food industries. However, products that conform with GMP guidelines are also required for the manufacture of cosmetics and fragrances or fl avors.

The materials selected, design of the surfaces and architecture of the overall system should prevent the accumulation of fluids and dirt. Cleaning, maintenance, inspection and servicing must be as safe and easy as the processes employed for the disinfection of mechanical components.

The VisuNet GMP product portfolio extends from simple direct monitors and remote monitor systems with Ethernet connection to a host, to complete PCs available with single or dual monitor systems and various mounting options. All models feature a 19-inch display with an optional touch screen. The stainless steel housings have an IP65 degree of protection. Remote monitors and PCs are equipped with Ethernet, USB, PS/2 and RS232 interfaces.



The VisuNet GMP product family guarantees a perfect fit for every system infrastructure. Four models are available depending on the functions required, the display and input unit and the distance over which the data is transferred. This manual describes the VisuNet GMP Direct Monitor (DM):

VisuNet GMP DM are direct monitors, which are directly connected to the VGA interface of the host. Industrial keyboards with integral mouse connected directly to the host are available as accessories.

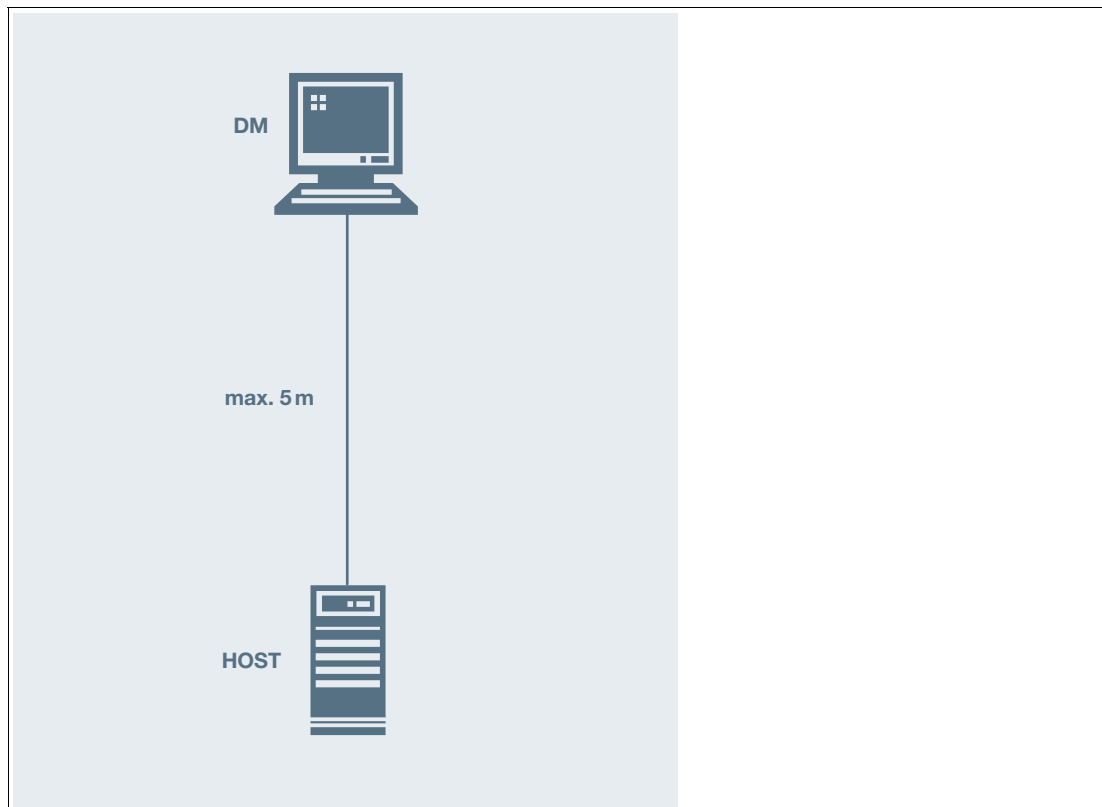

### Overview of features

- The brilliant display provides high meter-reading comfort
- Easy, user-friendly handling due to optionally available touch screen
- Image position, pixel frequency and phase will be detected and synchronized automatically
- Rugged stainless steel housing (304/1.4301 - others on demand)
- Degree of protection IP65
- High-end finish of all surfaces



## 2.2 Technical Data

	VisuNet GMP DM219	VisuNet GMP DM221	VisuNet GMP DM222
<b>General specifications</b>			
Type	Direct monitor		
<b>Supply</b>			
Power supply	20 ... 30 V DC		
Power consumption	40 W		
Indicators/operating means			
<b>Display</b>			
Type	TFT, LCD, High Color (24 bit)		
Screen diagonal	19 "	21,5 "	22 "
Resolution	1280 x 1024 Pixel	1920 x 1080 Pixel	1680 x 1050 Pixel
Representable colors	16,7 Mio.		
Brightness	300 cd/m <sup>2</sup>		
Input devices	Analog resistive touchscreen (optional) , Input device combined with keyboard and optional trackball/touch screen/joystick		
<b>Interface</b>			
Interface type	VGA		
<b>Ambient conditions</b>			
Ambient temperature	0 ... 50 °C	0 ... 50 °C	0 ... 50 °C
<b>Mechanical specifications</b>			
Protection degree	IP65		
Installation	panel mounting several mounting devices (rotatable/fix) available		
Mass	18 kg	20 kg	20 kg
Dimensions	568 mm x 450 mm x 65 mm	625 mm x 450 mm x 73 mm	625 mm x 450 mm x 73 mm

### 2.3 Dimensions VisuNet GMP DM series

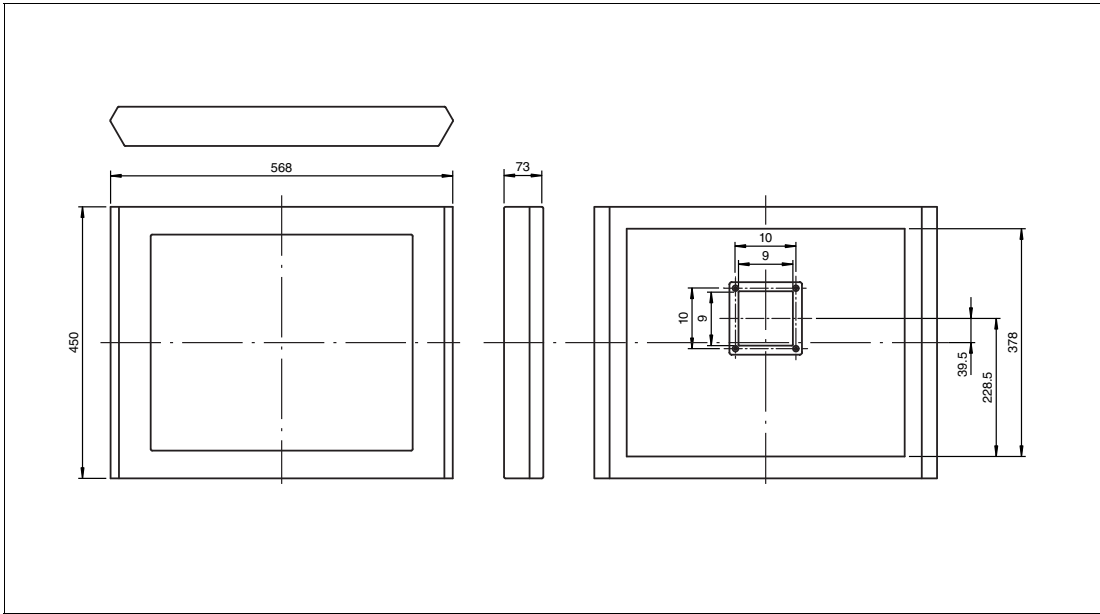

Figure 2.1 Dimensions DM219

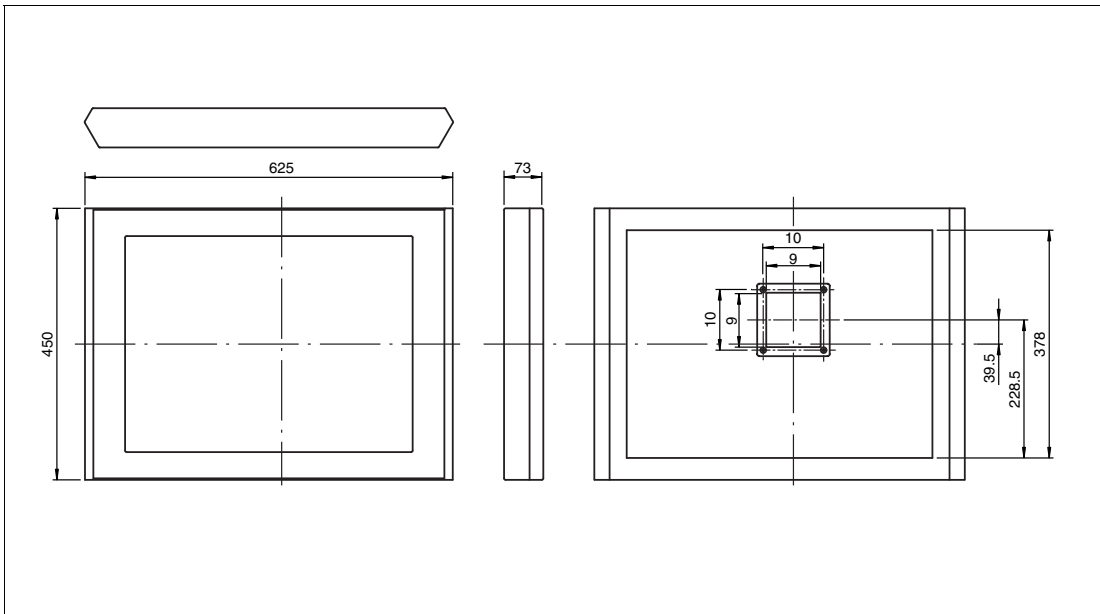

Figure 2.2 Dimensions DM221/DM222

## 2.4 Interfaces and connections VisuNet GMP DM

The interfaces and connections of the VisuNet GMP are located within the VESA adapter at the back of the housing.

The following interfaces are available:

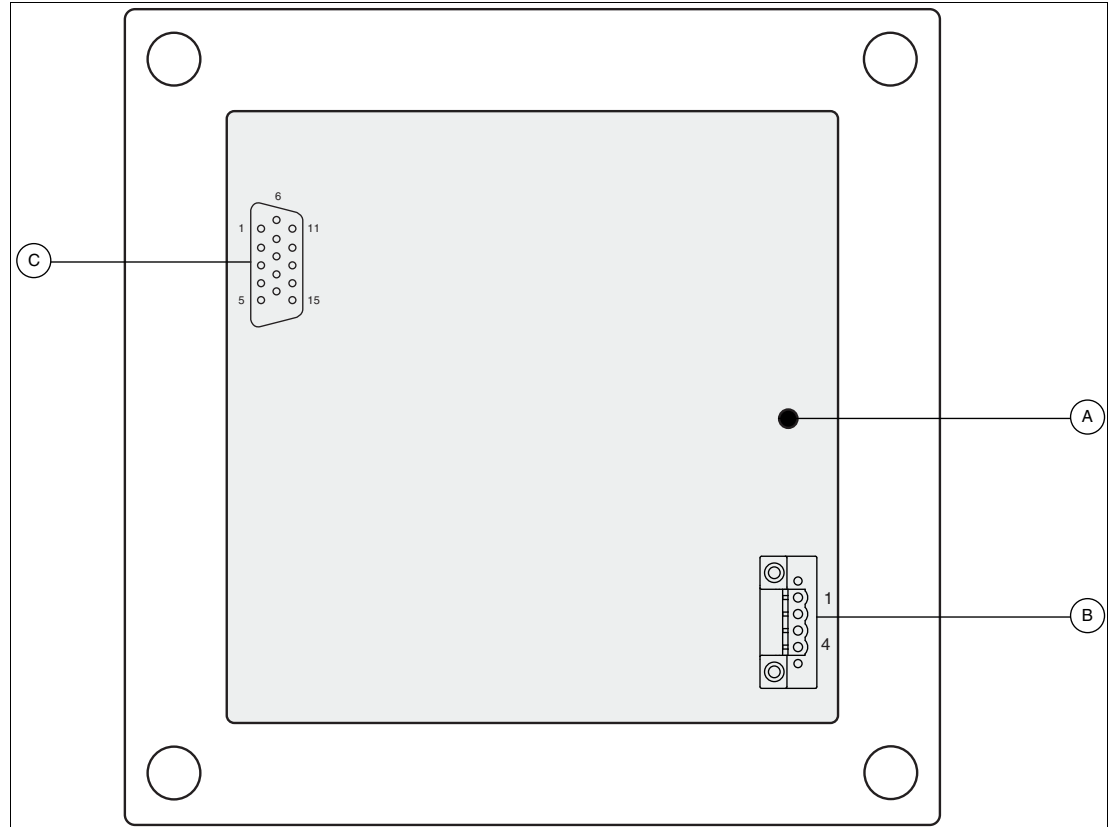

Figure 2.3 VESA adapter at the back of the VisuNet GMP housing

- A** grounding bolt
- B** Phoenix DFK-MSTB 2,5/ 4-GF-5,08
- C** VGA interface

### 2.4.1 VGA interface

15-pin HD-D-Sub socket "VGA" required for monitor/host connection.

Picture	Pin	Signal	Pin	Signal	Pin	Signal
	1	RED	6	RED_GND	11	not in use
	2	GREEN	7	GREEN_GND	12	IIC-DATA
	3	BLUE	8	BLUE_GND	13	HSYNC
	4	not in use	9	+ 5 V	14	VSYNC
	5	GND	10	GND	15	IIC-CLOCK

### 2.4.2 Supply Voltage 24 V

4-pin socket required for supply voltage connection (Phoenix Contact DFK-MSTB 2,5/ 4-GF-5,08).

The VisuNet GMP KM has inverse-polarity protection.

Matching plug: Phoenix Contact MSTBT 2,5/ 4-STF-5,08

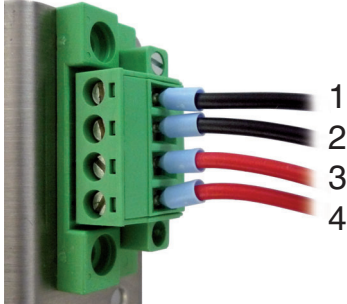
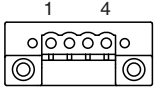
Picture	Pin	Signal
 	1	GND
	2	GND
	3	+ 24 V DC
	4	+ 24 V DC

### 2.4.3 Supply voltage 12 V (PA version)

Required for supply voltage connection via terminal block.

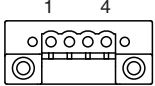
Picture	Pin	Signal
	1	GND
	2	GND
	3	+ 12 V DC
	4	+ 12 V DC

## 2.5 Accessories

The following accessories are available.

### 2.5.1 Keyboards

There are several keyboard models available. All keyboards have an antibacterial coating. For this reason the keyboards are perfectly suitable for environments with high hygienic standards.

#### Keyboard EXTA\*-K3

Keyboard with integrated trackball (mechanical/optical) for controlling the mouse pointer.  
2 separate buttons below the trackball assume the function of left and right mouse button.

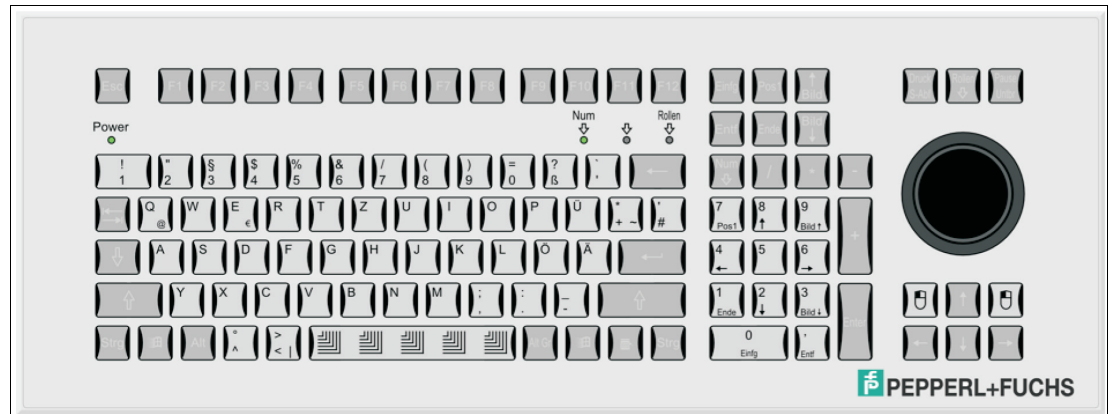

Figure 2.4 EXTA\*-K3

#### Keyboard EXTA\*-K4

Keyboard with integrated touchpad for controlling the mouse pointer.  
2 separate buttons below the touchpad assume the function of left and right mouse button.

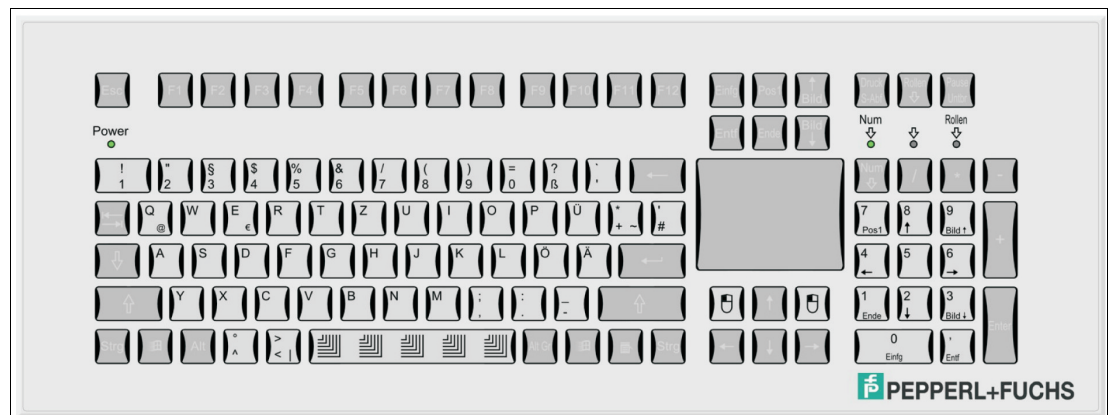

Figure 2.5 EXTA\*-K4

## Keyboard EXTA2-K6

Keyboard with integrated joystick for controlling the mouse pointer.

2 separate buttons below the joystick assume the function of left and right mouse button.



Figure 2.6 EXTA2-K6

## 2.5.2 Pedestals

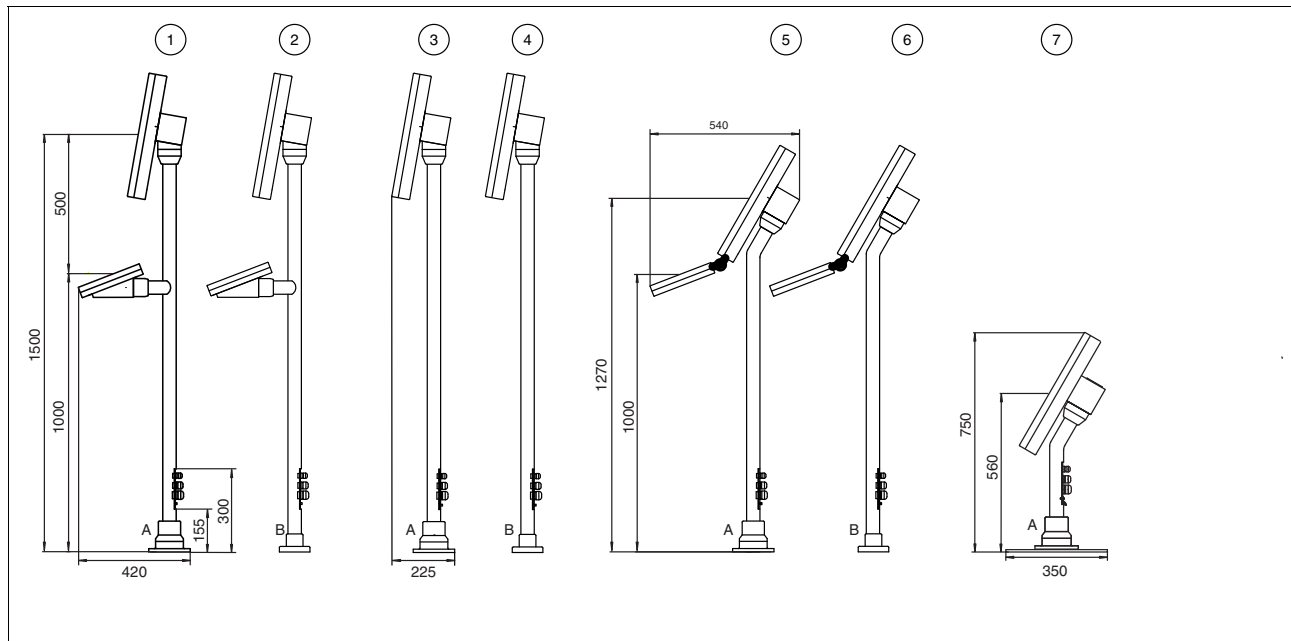

Figure 2.7 Pedestal models for VisuNet GMP

	Model number	Description
1	PEDESTAL1-150-1V-KP-G-T-304	Pedestal, turnable approx. 350°, inclination of monitor 10°, with pipe for keyboard
2	PEDESTAL1-150-1V-KP-G-F-304	Pedestal, fix mounted, inclination of monitor 10°, with pipe for keyboard
3	PEDESTAL1-150-1V-NP-G-T-304	Pedestal, turnable approx. 350°, inclination of monitor 10°
4	PEDESTAL1-150-1V-NP-G-F-304	Pedestal, fix mounted, inclination of monitor 10°

219365 2023-07

	Model number	Description
5	PEDESTAL1-130-3V-NP-G-T-304	Pedestal, turnable approx. 350°, inclination of monitor 30°
6	PEDESTAL1-130-3V-NP-G-F-304	Pedestal, fix mounted, inclination of monitor 30°
7	PEDESTAL1-56-3V-NP-G-T-304	Pedestal turnable approx. 350°, inclination of monitor 30°

### 2.5.3 Wall arm versions

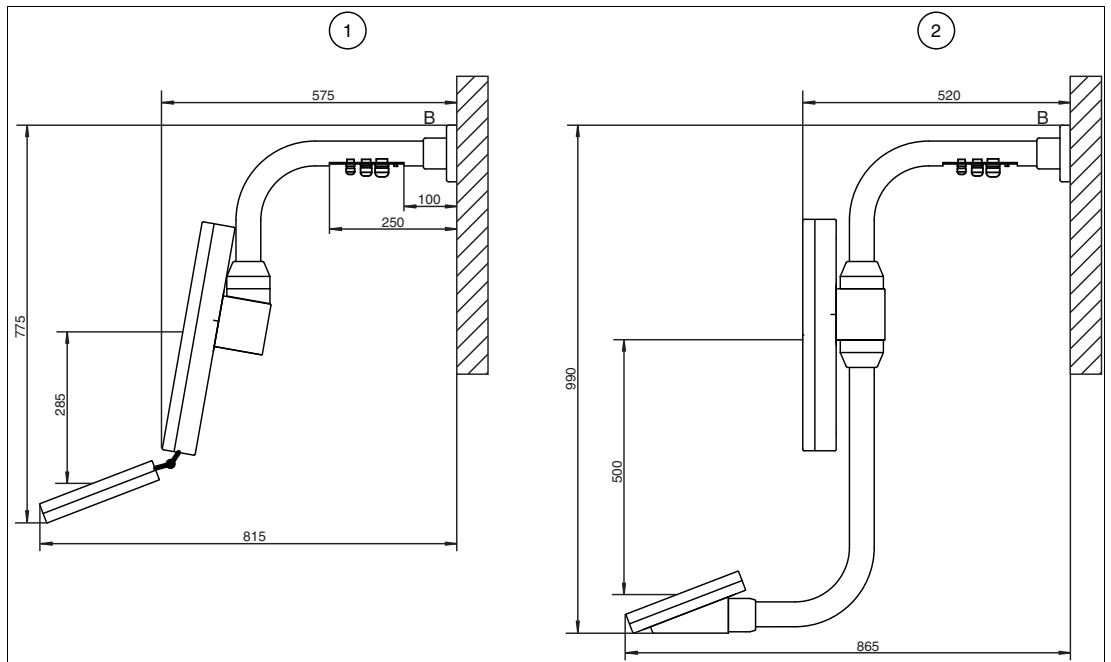

Figure 2.8 Wall arms for VisuNet GMP

	Model number	Description
1	WALL-ARM1-55-1V-NT-G-*-304	Wall arm, inclination of monitor 10°, without pipe for keyboard 2 models available: <ul style="list-style-type: none"> <li>WALL-ARM1-55-1V-NT-G-F-304: fix</li> <li>WALL-ARM1-55-1V-NT-G-T-304: approx. 350° turnable</li> </ul>
2	WALL-ARM1-55-0V-KT-G-*-304	Wall arm, without inclination of monitor, with pipe for keyboard 2 models available: <ul style="list-style-type: none"> <li>WALL-ARM1-55-0V-KT-G-F-304: fix</li> <li>WALL-ARM1-55-0V-KT-G-T-304: approx. 350° turnable</li> </ul>

### 2.5.4 Wall bracket

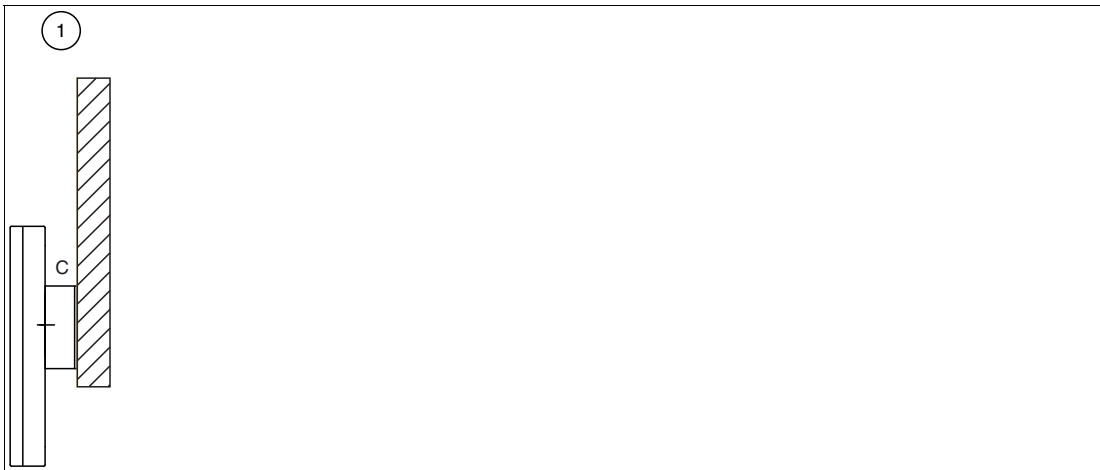

Figure 2.9 Wall bracket for VisuNet GMP

	Model number	Description
1	WALL-BRACKET1-0-0V-G-304	Wall bracket

### 2.5.5 Hole pattern of the mounting versions

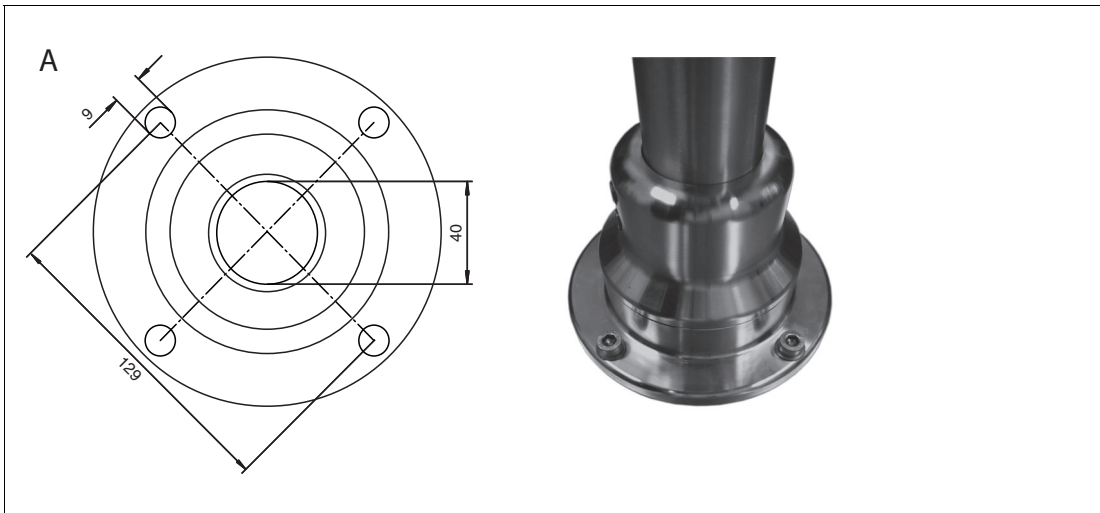

Figure 2.10 Bottom attachment, turnable, fastening at front



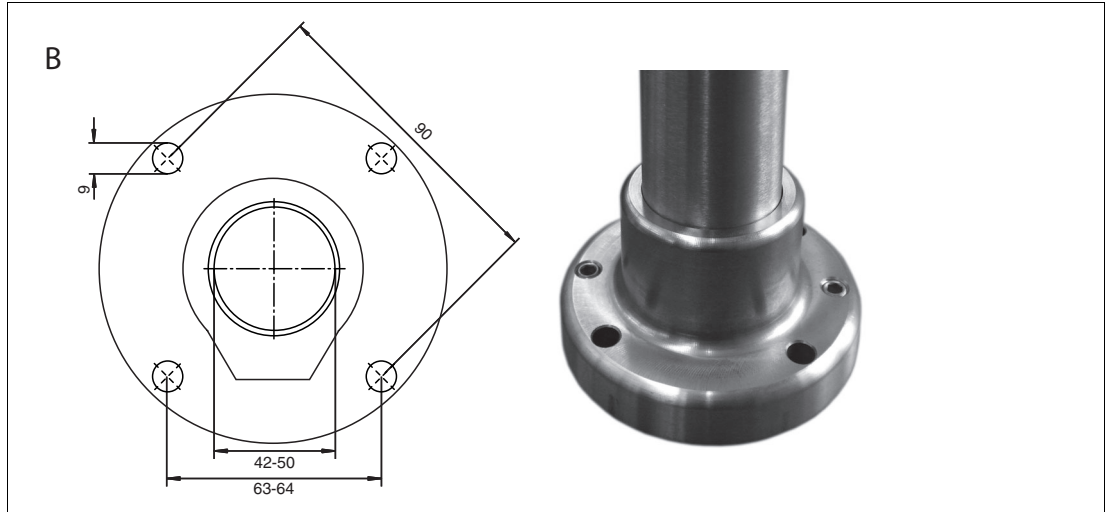

Figure 2.11 Bottom attachment, fix mounted

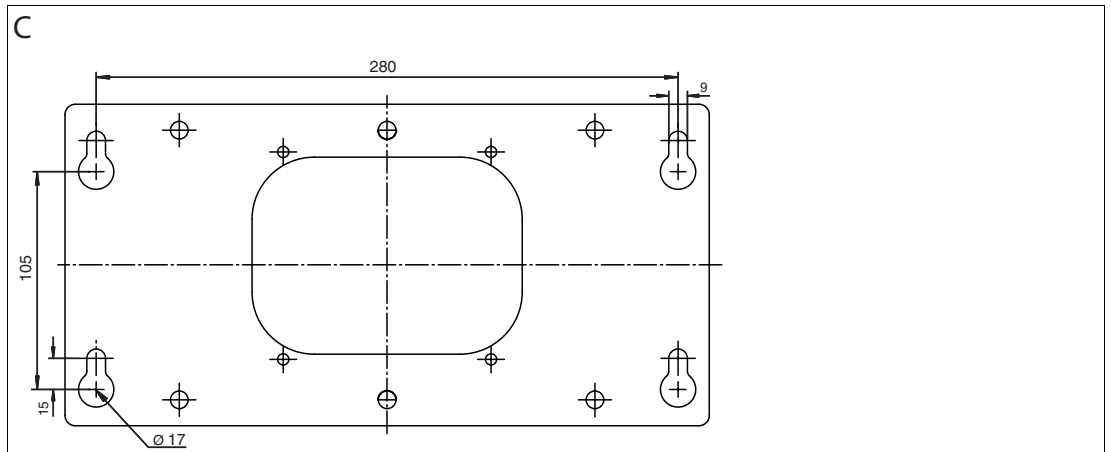

Figure 2.12 Wall bracket

## 2.5.6 Power supply accessories

### Power supply

Model number	Description
BN-24/5000-HS-10	Power supply
DATL-A2-2.5-0	Power cable 2x 2.5mm <sup>2</sup> , wire end ferrule, max. length 80 m
DATL-A2-4.0N/2.5F-1	Power cable 2x 4.0mm <sup>2</sup> +2.5m 2.5mm <sup>2</sup> , wire end ferrule, length: 110 m

## 3 Installation and Commissioning

### 3.1 Preparation



#### Unpacking the Device

1. Check the packaging and contents for damage.  
↳ In the event of damage, inform the shipping company and notify the supplier.
2. Check the package contents against your order and the shipping documents to ensure that all items are present and correct.  
↳ Should you have any questions, direct them to Pepperl+Fuchs.
3. Retain the original packaging in case the device is to be stored or shipped again at a later date.

### 3.2 Mounting in the field

The device is licensed for operation in confined spaces.

The cooling of the device does not require active components like CPU fan or water cooling systems. For that reason there are no ventilation slots in the housing.

To avoid overheating during operation, follow the advices below for field installation:

- Do not expose the device to direct solar radiation or other heat sources.
- Since the heat will dissipate via the housing, provide sufficient air circulation.
- Keep the ambient temperature below the specified maximal value.

---

#### Note

The device is not delivered in sterile condition.

---



### 3.2.1 Grounding at pedestal and wall arm



**Note**

Pepperl+Fuchs recommend to use a cable with a core-cross section of 4 mm<sup>2</sup> for grounding.

---

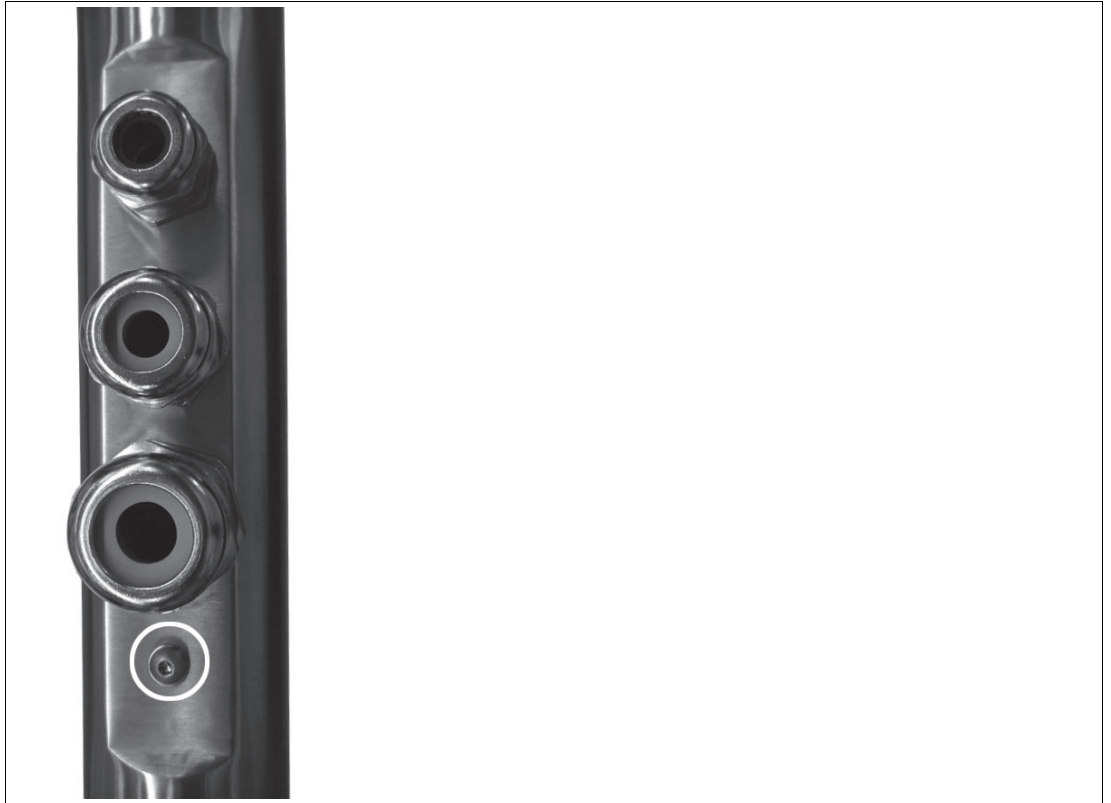

Figure 3.1 Ground connection at pedestal/wall arm



### Grounding VisuNet GMP at pedestal and wall arm



**Note**

Depending on the grounding cable you need the adequate cable lug (not included in delivery).

---

1. Insert the grounding cable into a cable lug (4).
2. Unscrew the M4 screw on ground connection.
3. Insert the cable of the cable lug between the 2 washers (1).
4. Tighten the screw.

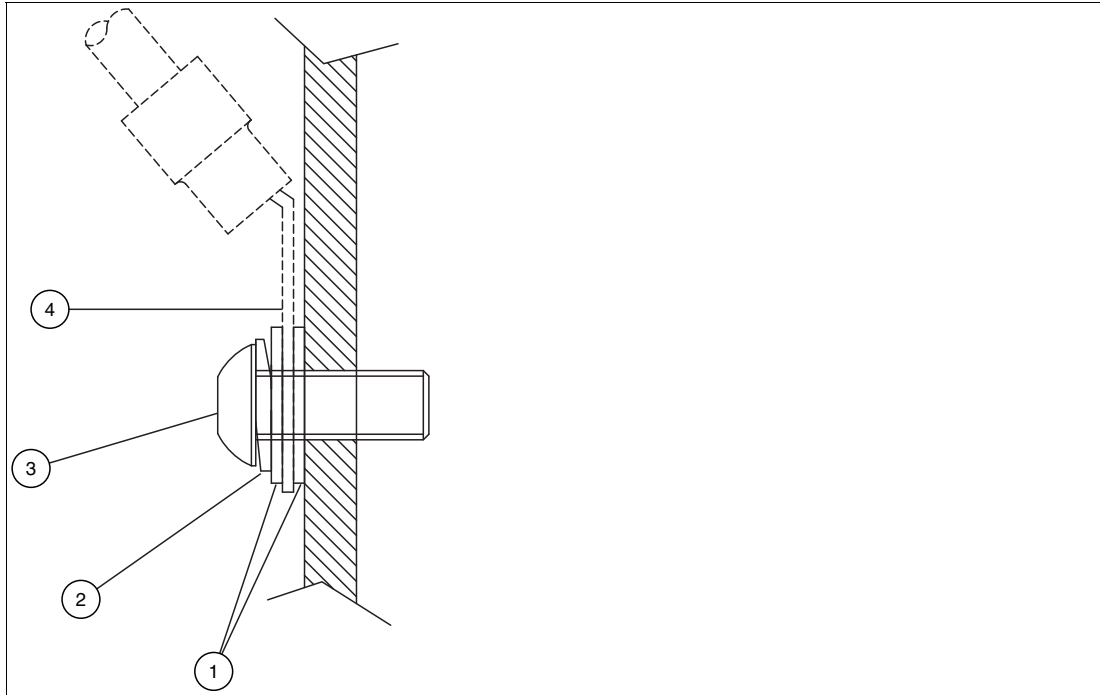

Figure 3.2 Grounding at Pedestal/Wall Arm

- 1 washer
- 2 lock washer
- 3 M4 screw
- 4 cable lug

### 3.3 Commissioning VisuNet GMP RM/PC

Use a low resistance connection between device and control cabinet.

Use cables with a minimum cross core-section of 2,5 mm<sup>2</sup> for power supply.



#### Turning on the VisuNet GMP

1. Connect the 4-pin plug with the 4-pin power supply socket at the back of the housing.
2. Fix and tighten the screws of the plug.
3. Switch on the power supply at source.

↳ After establishing the power supply the VisuNet GMP starts automatically. The green LED on the right hand side of the housing indicates a correct power supply.



#### Note

Use the VisuNet GMP only with safety-low voltage (protective extra-low-voltage). The power supply needs to be in line with applicable standards.



#### Turning off the VisuNet GMP

1. Disconnect the device from the power supply.
2. After that unscrew the power plug at the VisuNet GMP.

## 4 Operation

### 4.1 On Screen Display

VisuNet GMP features a graphical user interface for setting up the display via the **On screen display** (OSD menu). A control panel with four buttons for operating the system is located on the right hand side of the housing.

The following table describes the buttons and their function.

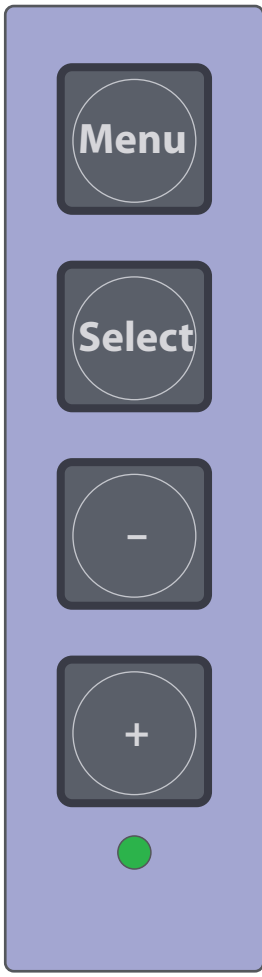
Picture	Button	Function	Description
	Menu	Menu selection	<ol style="list-style-type: none"> <li>1. First click: activates menu</li> <li>2. Second click: quits sub menu/menu</li> </ol>
	Select	menu access/selection	<ol style="list-style-type: none"> <li>1. Select menu entries</li> <li>2. Confirm active menu entries</li> </ol>
	-	downwards/left	<ol style="list-style-type: none"> <li>1. Navigate in menus: downwards/left</li> <li>2. Decrease a value</li> <li>3. shortcut for audio volume</li> </ol>
	+	upwards/right	<ol style="list-style-type: none"> <li>1. Navigate in menus: upwards/right</li> <li>2. Increase a value</li> </ol>
	LED	Status	red light: no signal green light: operating status "on"









## Selecting the OSD menu

1. To select the OSD menu, press the  button.  
The OSD menu is divided in the following menu items :
  - Color
  - Image Setting
  - Position
  - OSD Menu
  - Language
  - Misc.
  - Exit





## Navigating in the OSD menu

1. If applicable select the OSD menu.
2. Navigate to the designated tab with the  button (scroll to the right) and  button (scroll to the left) respectively.  
↳ The active tab will be marked.
3. To select a tab, press the  button.  
↳ The sub menu will be opened.
4. Navigate to the designated sub menu entry with the  button and the  button respectively
5. To select a sub menu, press the  button.  
↳ Depending on the menu you will get to another sub menu or to a dialog box.



## Adjusting values

1. To adjust values (i.g. brightness or contrast) in a sub menu, press the  button and the  button respectively.
2. After adjusting the value, quit the active dialog box by pressing the  button.  
↳ The adjusted value will be adopted and you will return to the designated sub menu.



## Quitting OSD menu/sub menus

1. To quit a sub menu, select the menu item **Back** or press the  button.

↳ The sub menu will be quit.



### Note

#### Image Sticking

Displaying a fixed pattern may cause burn-in-effects (image sticking due to the LCD characteristics).



To avoid image sticking change pattern frequently or activate screen saver.

Please note that damages at the display caused to burn-in-effects are not included in the warranty.

### 4.1.1

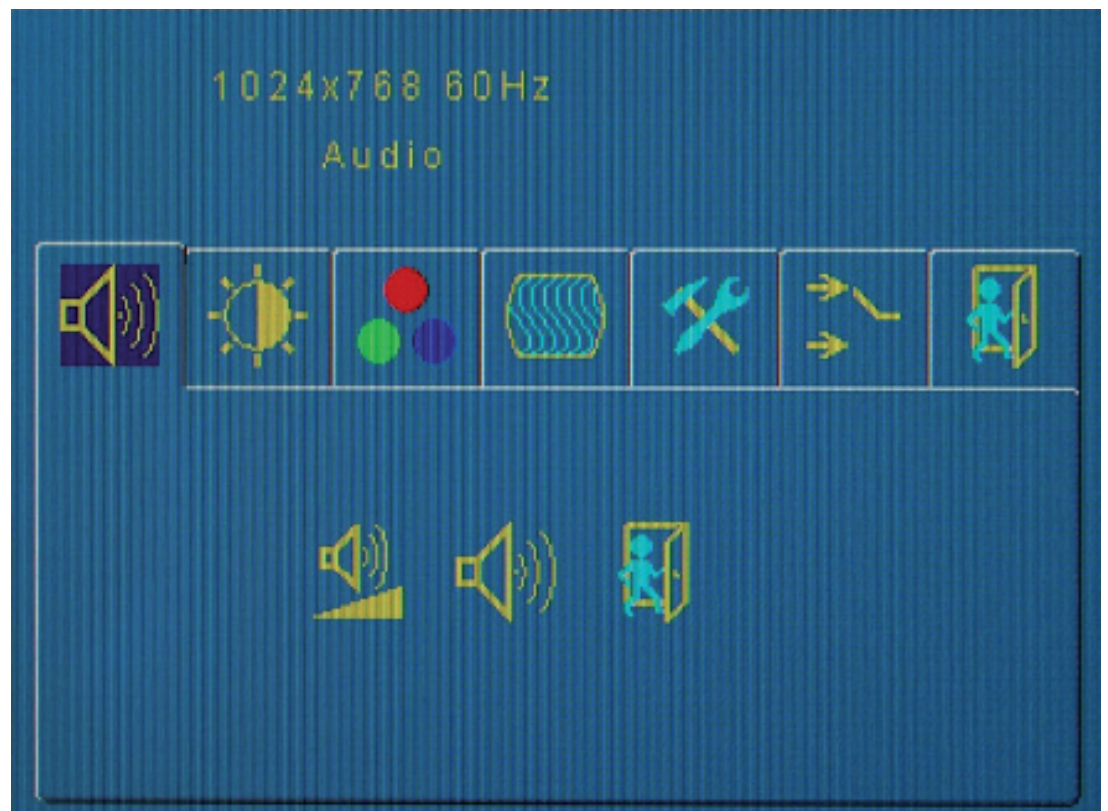
#### Audio menu



Menu item	Name	Description
	Volume	Change the volume
	Mute	Mute the audio
	Exit	Quit the sub menu and return to the menu one lever higher.





**Note**

The VisuNet GMP has no audio speaker.

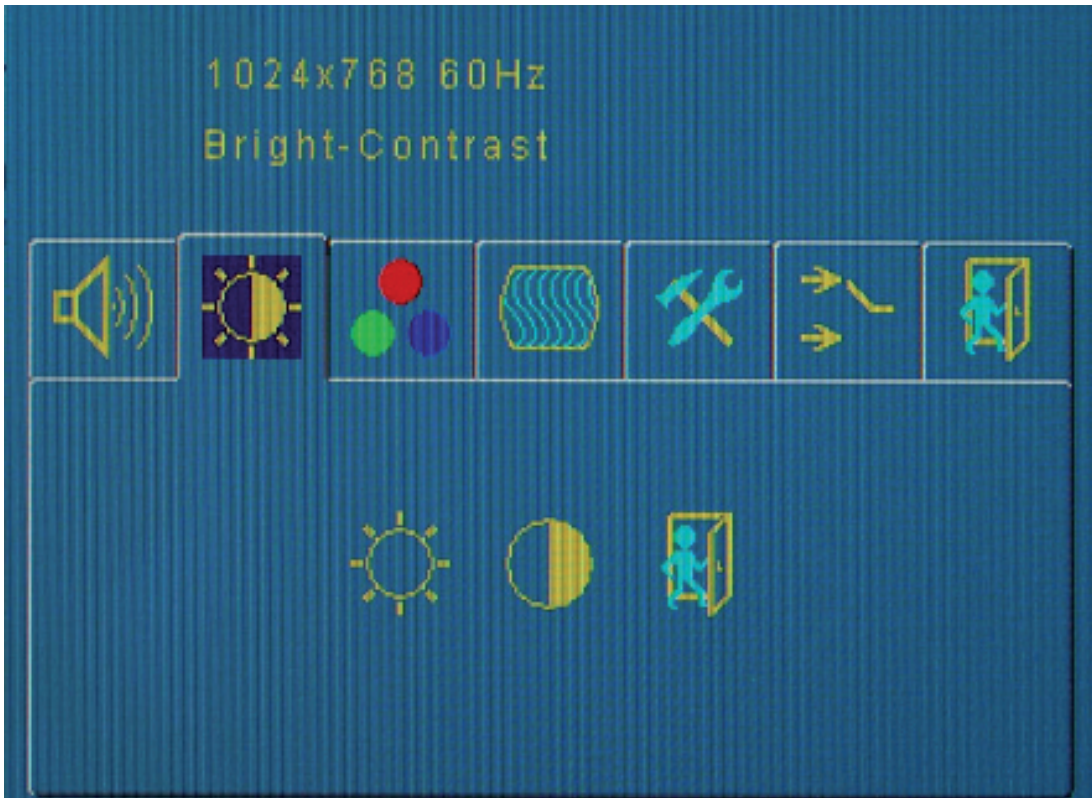
**4.1.2 Bright-Contrast menu**



Menu Item	Name	Description
	Brightness	Decrease/increase brightness
	Contrast	Decrease/increase contrast
	Exit	Quit the sub menu and return to the menu one lever higher.



### 4.1.3 Menu Color

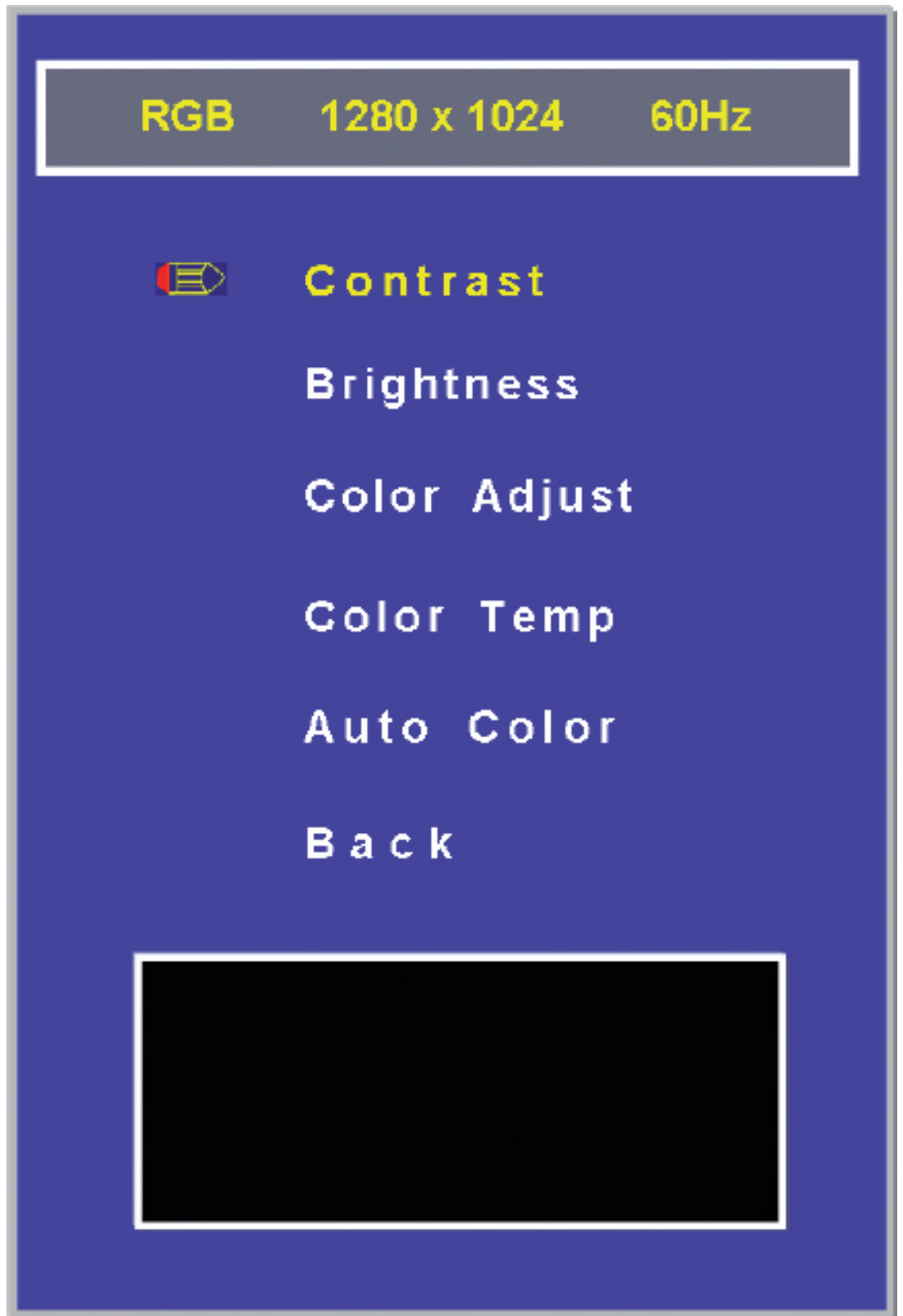

Sub menu	Description
Contrast	Adjust the contrast of the image
Brightness	Adjust the brightness of the image

219365 2023-07

Sub menu	Description
Color Adjust	Adjust the value of red, green and blue
Color Temp	Adjust the color temperature
Auto Color	Run the auto config of the color
Back	Back to main menu

4.1.4 Image menu







Sub menu	Description
Clock	Adjust the clock of the image
Phase	Adjust the phase of the image

219365 2023-07

Sub menu	Description
Gamma	Adjust the gamma level of the image
Sharpness	Adjust the sharpness of the image
Auto Adjust...	Run the auto config of the image
Back	Back to main menu

#### 4.1.5 Tools menu



Menu item	Name	Description
	OSD	Select more sub menus: time, horizontal, vertical, OSD menu direction, exit
	Reset	Reset to factory settings
	Sharpness	Change sharpness
	Language	Change language of OSD menu
	Exit	Quit the sub menu and return to the menu one level higher.

4.1.6 Input menu

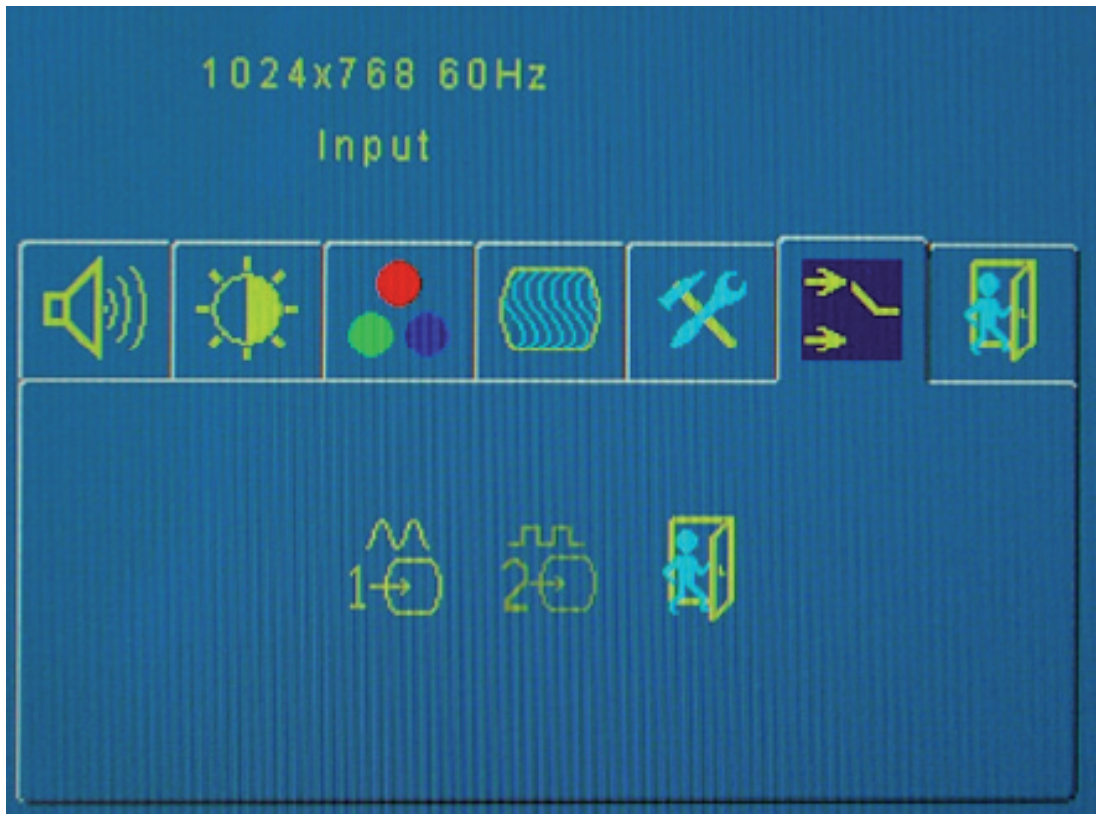

Menu item	Name	Description
	VGA	Activate VGA interface
	DVI	Activate DVI interface
	Exit	Quit the sub menu and return to the menu one lever higher

#### 4.1.7 Exit menu



## 5 Maintenance



### Note

As a part of regular maintenance and depending on the operating conditions (vibration, shocks, additional load...) it is recommended to check the torques (20 Nm / 30 Nm) of the set screws (see below).

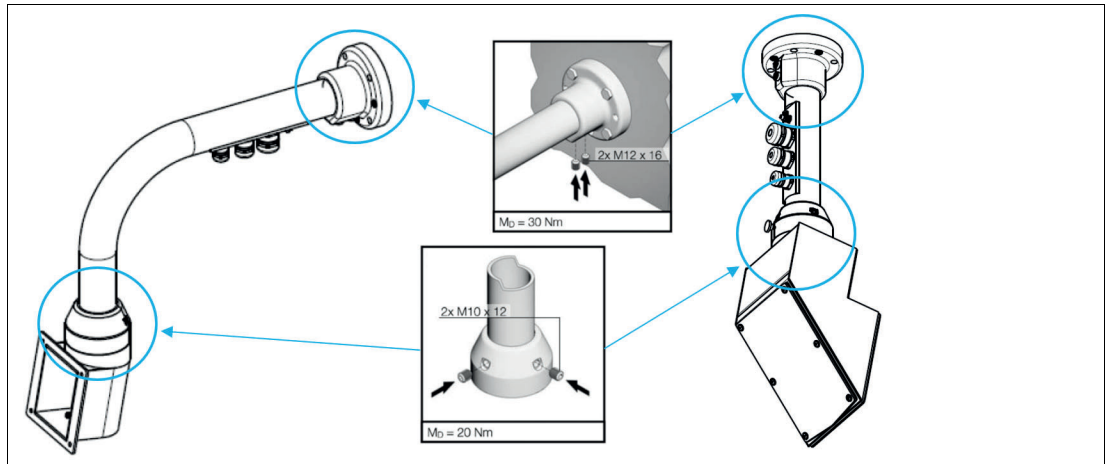

Figure 5.1 Possible wall arm constructions / applications

## 6 Appendix

### 6.1 Chemical resistance of keyboard foil

The keyboard foil is manufactured from a biaxially aligned polyester-based material and therefore has a greater resistance to solvents. The foil is stronger and more durable than other standard foils used on keyboards and front panels, such as polycarbonate and PVC.

The keyboard foil is resistant against the following substances: (Test method: DIN42115):

- Alcohols
- Dilute acids
- Dilute alkalis
- Esters
- Hydrocarbons
- Household cleaning

### 6.2 Chemical resistances of the touch screen

The foil is manufactured from a biaxially aligned polyester-based material and therefore has a greater resistance to solvents. It is physically resistant to pencil lead with a maximum hardness of 3HB.

The foil is resistant against the following substances (concentration 100 % - unless otherwise specified):

<b>Aldehyde:</b>	
Acetaldehyde	Formaldehyde 37 - 42 %
<b>Alcohols:</b>	
Ethanol	Hexahydrophenol
Triacetin	Dowandol DRM/PM
Glycol	Glycerin
Isopropanol	Methanol
	Diacetone alcohol
<b>Hydrocarbons:</b>	
Aliphatic hydrocarbons	generally gasoline
Kerosene	Toluol
Xylene	Benzene
<b>Chlorinated hydrocarbons:</b>	
Chlorofluorocarbons	Perchloroethylene
III-Trichloroethylene	Diethyl ether
Methyl ethyl ketone	Trichloroethylene
<b>Acids:</b>	
Formic acid <10 %	acetic acid <10 %
Phosphoric acid <10 %	Hydrochloric acid <10 %
Nitric acid <10 %	Trichloroacetic acid <10 %
	sulfuric acid <10 %
<b>Other organic solvents:</b>	
Ether	Acetone
Dimethylformamide	Dioxane

219365 2023-07



<b>Aldehyde:</b>	
Ethylidioctyl	Dibutyl phthalate
Phthalate	Butyl cellosolve
Iron chlorid (FeCl <sub>2</sub> )	Iron chlorid (FeCl <sub>3</sub> )
<b>Lyes:</b>	
Ammonia <10 %	Sodium hydroxide <10 %
	Alkali carbonate
<b>Ester:</b>	
Ethylacetate	N-butyl acetate
	Amyl acetate
<b>Technical oils and greases:</b>	
Drilling emulsion	Diesel oil
Varnish	Heating oil
Liquid paraffin	Castor oil
Silicone oil	Turpentine oil substitute
Brake fluid	Decon
<b>Saline solutions:</b>	
Alkali carbonate	Bichromate
Potassium hydroxide <30 %	Acetonitrile
sodium bisulfate	potassium ferrocyanide
	Sodium hypochlorite <20 %
<b>Various other substances:</b>	
Molecular chlorine	Cresol phenol soaps in hydrogen soution
Oxygen	Tricresyl phosphate
Water <100 °C	Hydrogen peroxid <25%
Saline water	Solvent (white spirit)
Grape juice	Milk
	Coffee
<b>Detergent, rising agent, cleaning agent:</b>	
Potash soap	Detergent solutions (surfactants)
Fabric softener	Sodium carbonate
<b>Household chemicals (24 hours of exposure at 50 °C)</b>	
Top Job	Jet Dry
Gumption	Fantastic
Formula 409	Ariel
Persil	Wisk
Lenor	Downey
Ajax	Vim
Domestos	Vortex
	Windex0

Resistance to surface desinfectant can be determined on request.

### Slight discoloration

Intense examinations established that the following products caused slight discoloration:

- Mustard
- Tomato juice
- Tomato ketchup
- Lemon juice

### No resistance

**Not** resistant to:

- concentrated mineral acids
- concentrated alkaline solutions
- High-pressure steam over 100 °C



---

#### Note

Various other substances may cause the surface structure to alter. Testing and subsequent assessment still require clarification.

---

### 6.3 Cofigurator VisuNet GMP DM

Monitor type	Screen type	Protection	Motherboard specification	Power supply	Housing	Keyboard housing	Keyboard / input device	Keyboard layout	Accessories	Options
<b>Monitor type</b>										
DM219	19 " Direct Monitor, SXGA (1280x1024 Pixel), ambient temperature 0 °C to 50 °C									
DM221	21.5 " Direct Monitor, HD1080 (1920x1080 Pixel), ambient temperature 0 °C to 50 °C									
DM222	22 " Direct Monitor, WSXGA (1680x1050 Pixel), ambient temperature 0 °C to 50 °C									
<b>Screen type</b>										
A	antiglare glass front (Lambda/4)									
R	Touch screen, resistive 5-wire									
<b>Protection</b>										
-GP	Industrial non-Ex version									
<b>Motherboard specification</b>										
-V1	Video VGA, 15p. cond- Sub-D connection									
<b>Power supply</b>										
DC	24 V DC, 50 W, 2.1 A typ/3.0 A peak									
<b>Housing</b>										
-SL1	Slim line housing, stainless steel (1.4301/304), IP 65, VESA100									
<b>Keyboard housing</b>										
N	No keyboard, no keyboard housing									
R	Keyboard housing, stainless steel (1.4301/304), prepared for 48 mm tubes "mounting concepts"									
C	Keyboard housing, tiltable 90° - 180°, stainless steel (1.4301/304), with hinges (nickel-plated aluminium)									
<b>Keyboard / input device</b>										
G0	No keyboard, no input device									
G4	Foil keyboard, built-in touch pad, IP 65, 0 °C to 50 °C									
G7	Foil keyboard, mechanical built-in trackball, IP 65 (when not operated), 0 °C to 50 °C									
G8	Foil keyboard, optical built-in trackball, IP 65, 0 °C to 50 °C									
<b>Keyboard layout</b>										

219365 2023-07

Monitor type	Screen type	Protection	Motherboard specification	Power supply	Housing	Keyboard housing	Keyboard / input device	Keyboard layout	Accessories	Options
								<b>L0</b>	No keyboard, no keyboard layout	
								<b>DE</b>	German keyboard layout	
								<b>US</b>	US international keyboard layout	
								<b>FR</b>	French keyboard layout	
								<b>DK</b>	Danish keyboard layout	
								<b>ES</b>	Spanish keyboard layout	
								<b>Accessories</b>		
								<b>-S0</b>	No special accessories	
								<b>Options</b>		
								<b>-N</b>	No options	
								<b>-Y</b>	Non standard customized version	

# Your automation, our passion.

## Explosion Protection

- Intrinsic Safety Barriers
- Signal Conditioners
- FieldConnex® Fieldbus
- Remote I/O Systems
- Electrical Ex Equipment
- Purge and Pressurization
- Industrial HMI
- Mobile Computing and Communications
- HART Interface Solutions
- Surge Protection
- Wireless Solutions
- Level Measurement

## Industrial Sensors

- Proximity Sensors
- Photoelectric Sensors
- Industrial Vision
- Ultrasonic Sensors
- Rotary Encoders
- Positioning Systems
- Inclination and Acceleration Sensors
- Fieldbus Modules
- AS-Interface
- Identification Systems
- Displays and Signal Processing
- Connectivity

### Pepperl+Fuchs Quality

Download our latest policy here:

[www.pepperl-fuchs.com/quality](http://www.pepperl-fuchs.com/quality)

