

DA6-IU-2K-V DA6-IU-2K-C

Process Controllers

for analogue input signals
with Totaliser function



english



Table of Contents (German is the original version.)

1	Preface	3
2	Safety instructions and Warnings	3
2.1	Use according to the intended purpose	3
2.2	Mounting in a control panel	3
2.3	Electrical Installation	4
2.4	Cleaning and maintenance	4
3	Description	5
4	Display/Operating elements	5
5	Block diagram	6
6	Connections	6
7	Operating concept (Operating mode)	7
8	Programming	8
9	Function Groups	10
9.1	Help Texts (running text)	10
9.2	Signal inputs	10
9.3	User Linearisation	11
9.4	Function Multifunction Key (MP-Key) and Multifunction inputs (MP-INP)	13
9.4.1	Multifunction Key	14
9.4.2	Multifunction Inputs	14
9.5	Totaliser function	15
9.6	Limit Value (Alarm) Monitoring	17
10	Monitoring of Measuring Circuit	19
11	Technical Data	20
11.1	General Data	20
11.2	Measuring signal inputs	20
11.3	Control Inputs MPI 1 / MPI 2	20
11.4	Alarm outputs	20
11.5	Supply voltage	20
11.6	Sensor Supply voltage	20
11.7	Climatic Conditions	20
11.8	EMC	20
11.9	Device Safety	20
11.10	Mechanical Data	21
11.11	Connections	21
12	Dimensional Drawings	21
13	Help Texts	22

1 Preface



Please read this instruction manual entirely and carefully before installation and start-up. Please observe all warnings and advice, both for your own safety and for general plant safety. If the device is not used in accordance with this instruction manual, then the intended protection can be impaired.

2 Safety instructions and Warnings



Please use the device only if its technical condition is perfect. It should be used only for its intended purpose. Please bear in mind safety aspects and potential dangers and adhere to the operating instructions at all times.

Defective or damaged devices should be disconnected from the mains immediately and taken out of operation. The device shall not be opened. Use the repair service of the manufacturer. Only connect the device to the electricity networks provided to that purpose.

The safety of the system in which the device is integrated is the responsibility of the installer.

Disconnect all electricity networks prior to any installation or maintenance work.

Use exclusively cables approved in your country and designed for your temperature and power ranges.

Installation and service work shall be carried out exclusively by qualified personnel.

The device must compulsorily be protected with approved external fuses. The value of these fuses can be found in the technical information.



This symbol is used on the device to remind of the existence of dangers, which are referred to in this manual.

2.1 Use according to the intended purpose

The purpose of the Process Control devices is to display measured values, as well as to monitor limit values (alarms). The application areas for this device lie in industrial processes and controls.

The application area for this device lies in industrial processes and controls, in the fields of manufacturing lines for the metal, wood, plastics, paper, glass, textile and other like industries. Over-

voltages at the terminals of the device must be kept within the limits of Over-voltage Category II. The device must only be operated when mounted in a panel in the correct way and in accordance with the section "Technical Data".

The device is not suitable for use in hazardous areas and for areas excluded in EN 61010 Part 1. If the device is used to monitor machines or processes in which, in the event of a failure of the device or an error made by the operator, there might be the risk of damaging the machine or causing an accident to the operators, it is your responsibility to take the appropriate safety measures.

The device has been designed for indoor operation. It may nevertheless be used outdoors, provided the technical data is adhered to. In this case, take care to provide suitable UV protection.

2.2 Mounting in a control panel



CAUTION

Mount the device away from heat sources and avoid direct contact with corrosive liquids, hot steam or similar.

Provide a free space of 10mm all around the device for its ventilation.

The device should be mounted so that the terminals are out of the reach of the operator and cannot be touched by him. When mounting the device, consider the fact that only the front side is classified as accessible for the operator.

Mounting instructions

1. Remove the mounting clip from the device.
2. Insert the device from the front into the panel cut-out, ensuring the front-panel gasket is correctly seated.
3. Slide the fixing clip from the rear onto the housing, until the spring clamps are under tension and the upper and lower latching lugs have snapped into place.

Note: In case of proper installation, IP65 can be reached on the front side.

2.3 Electrical Installation



DANGER

The device must be disconnected from any power supply prior to any installation or maintenance work. Make sure that no more voltages LIABLE TO CAUSE AN ELECTROCUTION are present.

AC-powered devices must only be connected to the low-voltage network via a switch or circuit breaker installed close to the device and marked as their disconnecting device.

Installation or maintenance work must only be carried out by qualified personnel and in compliance with the applicable national and international standards.

Take care to separate all extra-low voltages entering or exiting the device from hazardous electrical conductors by means of a double or reinforced insulation (SELV circuits).



DANGER

The device must be protected externally for its proper operation. Information about the prescribed fuses can be found in the technical information.

The relay outputs are not protected internally in the device. Without suitable protection of the relay outputs, undesired heat development or even fire may occur. The relay outputs must be protected externally by the manufacturer of the plant. It must also be made sure that, even in case of a malfunction, the values stated in the technical data are under no circumstances exceeded.

- During installation, make sure that the supply voltage and the wiring of the output contacts are both fed from the same mains phase, in order not to exceed the maximum permitted voltage of 250V.
- The cables and their insulation must be designed for the planned temperature and voltage ranges. Regarding the type of the cables, adhere to the applicable standards of the country and of the plant. The cross sections allowed for the screw terminals can be found in the technical data.

- Before starting the device, check the cables for proper wiring and tightening. The screws of unused screw terminals must be screwed to the stop, so that they cannot loosen and get lost.
- The device has been designed for overvoltage category II. If higher transient voltages cannot be excluded, additional protection measures must be taken in order to limit the overvoltage to the values of CAT II.

Advice on noise immunity

All connections are protected against external sources of interference. The installation location should be chosen so that inductive or capacitive interference does not affect the device or its connecting lines! Interference (e.g. from switch-mode power supplies, motors, clocked controllers or contactors) can be reduced by means of appropriate cable routing and wiring.

Measures to be taken:

- Use only shielded cable and control lines. Connect shield at both ends. The conductor cross-section of the cables should be a minimum of 0.14 mm².
- The shield connection to the equipotential bonding should be as short as possible and with a contact area as large as possible (low-impedance).
- Only connect the shields to the control panel, if the latter is also earthed.
- Install the device as far away as possible from noise-containing cables.
- Avoid routing signal or control cables parallel to power lines.

2.4 Cleaning and maintenance

The front side of the unit should only be cleaned using a soft damp (water!) cloth. Cleaning of the embedded rear side is not planned and is the responsibility of the service personnel or of the installer.

In normal operation, this device is maintenance-free. Should the device nevertheless not operate properly, it must be sent back to the manufacturer or to the supplier. Opening and repairing the device by the user is not allowed and can adversely affect the original protection level.

3 Description

Digital panel meter for displaying measured values, as well as monitoring limit values in industrial applications.

- 6-digit 14-segment LED display, 14 mm, for displaying measured values and dialogs
- Running text can be switched on as Help Text
- Language for the Help Text selectable as English or German
- Signal input for 0 – 10 V, 2 – 10 V, ± 10 V, 0 – 20 mA and 4 – 20 mA
- Sampling rate 10 readings per second
- Digital filter (1st order) for smoothing display fluctuations with unstable input signals
- Customised linearisation
- MIN/MAX memory function
- Totaliser function
- 2 Relay outputs (changeover contacts) for limit monitoring
- Start delay for relay outputs after Power ON
- Versions for supply voltage 10 ... 30 V DC and 100 ... 240 V AC $\pm 10\%$
- Auxiliary power supply 15 V DC / 25 mA
- Additional aux. power output 24 V / 30 mA with AC supply
- Programmable via the front keys
- Multifunction key and two multifunction inputs, function programmable

4 Display/Operating elements

(1) Display		
- 14 segment display, 6-digit, red		
- Height of figures 14 mm		
(2) Status display, 2 LED annunciators, red		
- Switching status of Alarm 1 and Alarm 2		
- Indication Function Group or Function		
(3) MP-Key and Programming Keys		
	- Multifunction key (MP-Key)	
	- Return from Function Group - Return from Function	
	- Select previous Function Group - Select previous Function - Decrement parameter value	
	- Select next Function Group - Select next Function - Increment parameter value	
	- Enter a Function Group - Enter a Function - Accept the new setting	
(4) Space for unit overlay		

To enter the Programming Menu	+ > 3 sec
To display Device Type and Software Version	+ + > 5 sec
To restore factory default settings	+ > 3 sec

5 Block diagram

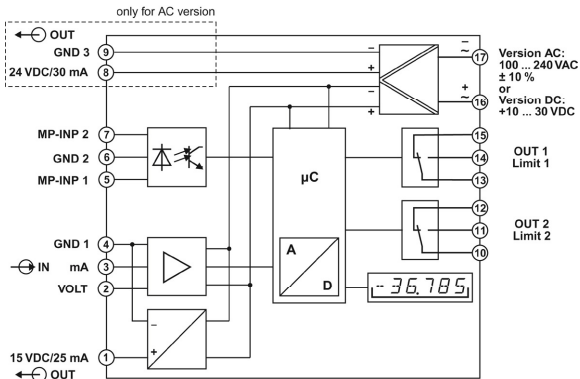

6 Connections

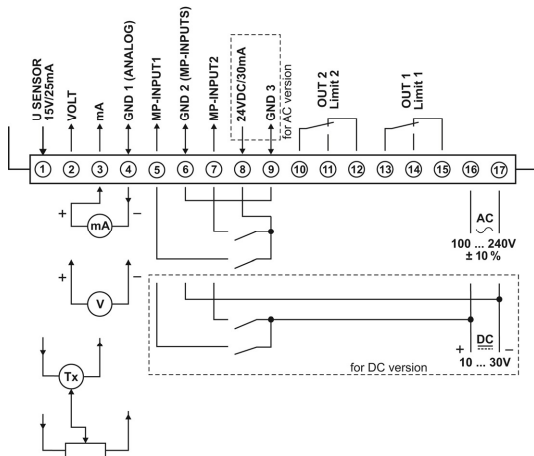

7 Operating concept (Operating mode)

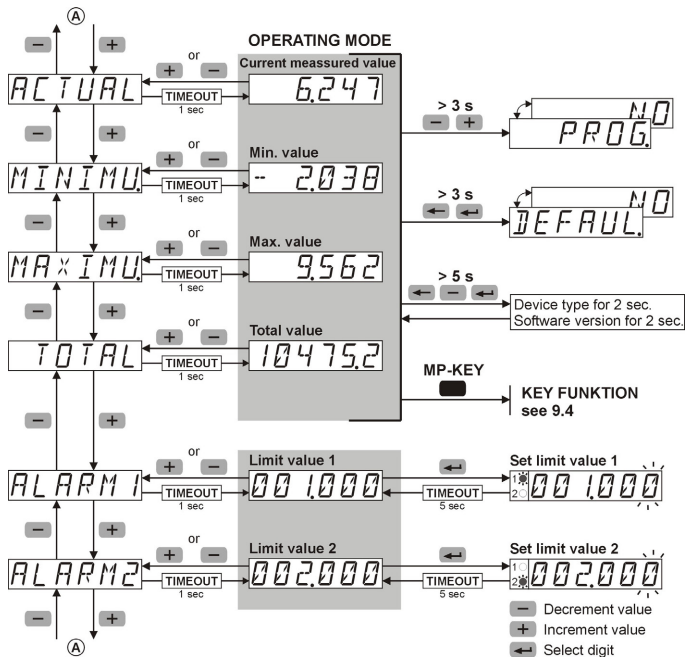

8 Programming

To enter the Programming menu

− + > 3 sec



- During programming the relays are inactive (not energised).
- When quitting the programming menu via SAVE, the minimum and maximum values and the totaliser value are all cleared.

Entering the Programming Menu / Selecting Function Group / Quitting the Programming menu

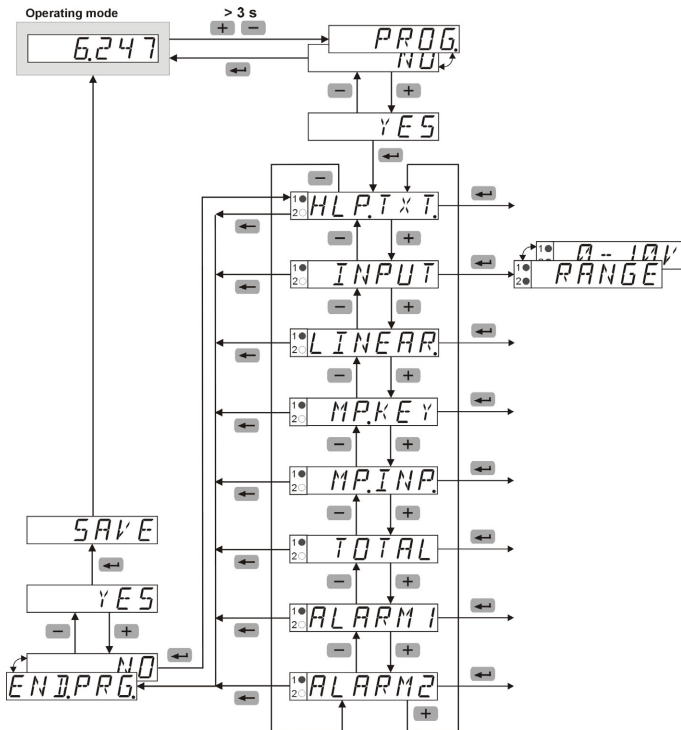

Selecting Function / Setting Parameters / Accepting Parameters

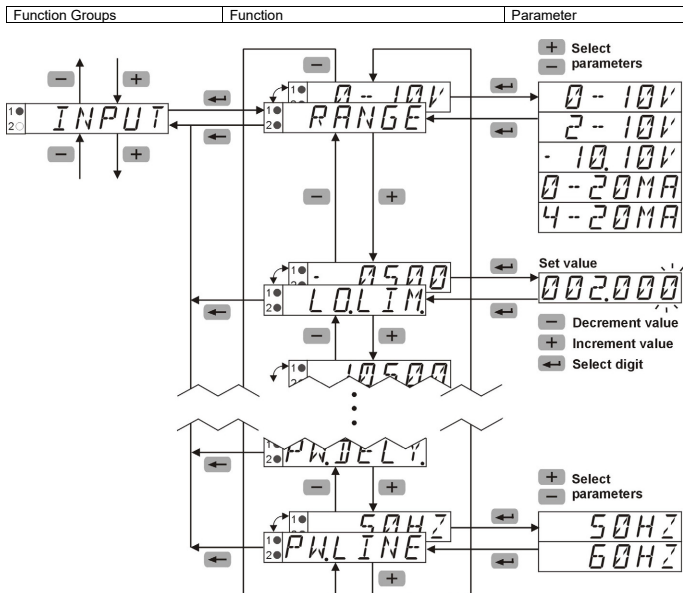

9 Function Groups



Factory settings are highlighted grey.

9.1 Help Texts (running text)

HLP.TXT.	Help Text menu
HLP.TXT.	Select Help Text
ON	ON - a running text that has started can be aborted with any programming key
OFF	OFF
S.L.L.A.N.G.	Select language for Help Text
EN	English
DE	Deutsch (German)

9.2 Signal inputs

INPUT	Menu Input Signal
RANGE	Select measuring range
0-10V	Meas. range 0 ... 10 V
2-10V	Meas. range 2 ... 10 V
-10.10V	Meas. range -10 ... +10 V
0-20mA	Meas. range 0 ... 20 mA
4-20mA	Meas. range 4 ... 20 mA
LO.LIM.	Select lower measuring range limit
-0.500	Input range depends on meas. range [V / mA]
HI.LIM.	Select upper measuring range limit
10.500	Input range depends on meas. range [V / mA]
DP.	Select decimal point (optical function only)
0.000	0 0.0 0.00 0.000 0.0000
INP.LO.	Select input low value
0.000	Input range depends on meas. range [V / mA]
DISP.LO.	Select display low value for INP.LO.
0.000	Input range

	-199999 ... +999999 and DP
INPHI.	Select input high value
10.000	Input range depends on meas. range [V / mA]
DISPHI.	Select display high value for INP.HI.
10.000	Input range -199999 ... +999999 and DP
FILTER	Select Input Filter The Filter function shows how many measurement cycles are used to determine the moving average.
1	Input range 1 ... 99 [cycles] - with a value of 1 the filter function is switched off
PWDEL.	Select Start Delay after Power On (limit monitoring is processed only after the programmed time has expired)
0.0	Input range 0.0 ... 99.9 [sec]
PWFREQ	Select local mains frequency
50HZ	Mains frequency 50 Hz
60HZ	Mains frequency 60 Hz



Input range depends on measuring range:
0 ... 10 V = -0.500 ... 10.500 [V]
2 ... 10 V = 1.500 ... 10.500 [V]
-10 ... +10 V = -10.500 ... +10.500 [V]
0 ... 20 mA = -0.500 ... 21.000 [mA]
4 ... 20 mA = 3.000 ... 21.000 [mA]

The functions LO.LIM and HI.LIM limit the editable range.

The value for HI.LIM must always be greater than the value for LO.LIM.

9.3 User Linearisation

<i>LINEAR.</i>	Menu User Linearisation
<i>LINEAR.</i>	Select User Linearisation
<i>NO</i>	Linearisation OFF
<i>YES</i>	Linearisation ON
<i>NUMPNT.</i>	Select number of linearisation (control) points
<i>3</i>	Input range 3 ... 12
<i>INP.LO.</i>	Select input low value
<i>0.000</i>	Input range depends on measuring range [V / mA]
<i>DISP.LO.</i>	Select display low value for INP.LO.
<i>0.000</i>	Input range -199999 ... +999999 and DP
<i>INP.01</i>	Select input value 1
<i>0.000</i>	Input range depends on measuring range [V / mA]
<i>DISP.01</i>	Select display value for INP.01.
<i>0.000</i>	Input range -199999 ... +999999 and DP
<p>A maximum of 12 linearisation points is possible. An input value INP must be entered for each linearisation point (LP) - input of the sensor value from the analogue input in physical units - as well as the corresponding display value DISP for this sensor value. The linearisation points (LP) may be entered in any order. They are then sorted in the firmware in ascending order for the linearisation function. Linearisation based on a negative slope is possible.</p>	
<i>INP.10</i>	Select input value 10
<i>0.000</i>	Input range depends on measuring range [V / mA]
<i>DISP.10</i>	Select display value for INP.10.
<i>0.000</i>	Input range -199999 ... +999999 and DP
<i>INP.HI.</i>	Select input high value
<i>10.000</i>	Input range depends on measuring range [V / mA]
<i>DISP.HI.</i>	Select display high value for INP.HI.
<i>10.000</i>	Input range -199999 ... +999999 and DP

i Input range depends on measuring range:
 0 ... 10 V = -0.500 ... 10.500 [V]
 2 ... 10 V = 1.500 ... 10.500 [V]
 -10 ... +10 V = -10.500 ... +10.500 [V]
 0 ... 20 mA = -0.500 ... 21.000 [mA]
 4 ... 20 mA = 3.000 ... 21.000 [mA]

The functions LO.LIM and HI.LIM limit the editable range.

The value for HI.LIM must always be greater than the value for LO.LIM.

Example for linear scaling

Example 1: 0 ... 10 V = 0 ... 600

Example 2: 4 ... 20 mA = 300 ... 900

Example 3: 1.0 ... 9.0 V = 750 ... 400

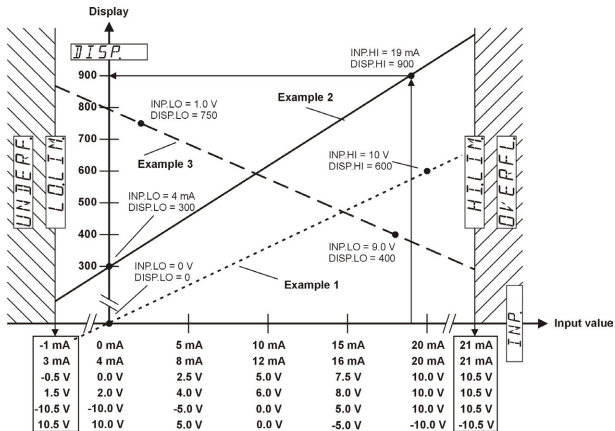

Example for non-linear scaling

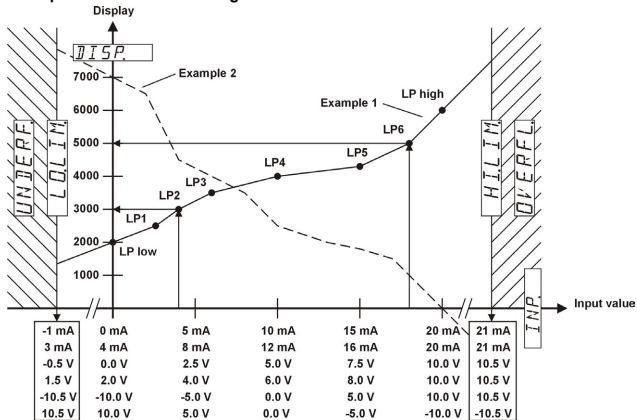

9.4 Function Multifunction Key (MP-Key) and Multifunction inputs (MP-INP)

Tare

- In the function group MP.KEY, programme the function TARA to ON. In the operating mode select the current measured value (ACTUAL) and briefly press the MP Key.
- In the function group MP.INP, programme the function MP.INP1 or MP.INP2 to TARA. In the operating mode briefly activate the multifunction input 1 or multifunction input 2.

Reset Tare Value

- In the function group MP.KEY, programme the function TARA to ON. In the operating mode select the current measured value (ACTUAL) and press the MP Key >5 sec.
- In the function group MP.INP, programme the function MP.INP1 or MP.INP2 to R.TARA. In the operating mode briefly activate the multifunction input 1 or multifunction input 2.

Reset MIN value memory

- In the function group MP.KEY, programme the function RES.MIN to ON. In the operating mode select the minimum value memory (MINIMU) and briefly press the MP Key.
- In the function group MP.INP, programme the function MP.INP1 or MP.INP2 to RES.MIN or R.PEAKS. In the operating mode briefly activate the multifunction input 1 or multifunction input 2.

Reset MAX value memory

- In the function group MP.KEY, programme the function RES.MAX to ON. In the operating mode select the maximum value memory (MAXIMU) and briefly press the MP Key.
- In the function group MP.INP, programme the function MP.INP1 or MP.INP2 to RES.MAX or R.PEAKS. In the operating mode briefly activate the multifunction input 1 or multifunction input 2.

Reset of relay outputs in Latch mode

- In the function group MP.KEY, programme the function RES.REL to ON. In the operating mode briefly press the MP Key.
- In the function group MP.INP, programme the function MP.INP1 or MP.INP2 to RES.REL. In the operating mode briefly activate the multifunction input 1 or multifunction input 2.

Reset Totaliser

- In the function group MP.KEY, programme the function RES.TOT to ON. In the operating mode, select the totaliser (TOTAL) and briefly press the MP Key.
- In the function group MP.INP, programme the function MP.INP1 or MP.INP2 to RES.TOT. In the operating mode briefly activate the multifunction input 1 or multifunction input 2.

Display Hold

- In the function group MP.INP, programme the function MP.INP1 or MP.INP2 to DISP.HD. In the operating mode, select either the current measured value (ACTUAL) or the totaliser (TOTAL) and activate multifunction input 1 or multifunction input 2.

Lock-out Limit Value (Alarm) setting

- In the function group MP.INP, programme the function MP.INP1 or MP.INP2 to LOC.ALAR. In the operating mode, activate multifunction input 1 or multifunction input 2.

Lock-out Programming and Default setting

- In the function group MP.INP, programme the function MP.INP1 or MP.INP2 to LOC.PRG. In the operating mode, activate multifunction input 1 or multifunction input 2.

Lock-out Keypad

- In the function group MP.INP, programme the function MP.INP1 or MP.INP2 to LOC.KEY. In the operating mode, activate multifunction input 1 or multifunction input 2.

9.4.1 Multifunction Key

<i>MPKEY</i>	Menu Function MP-Key
<i>TARA</i>	Select function: Reset tare (TARA) value with MP-Key – only when current measured value appears in the display
<i>OFF</i>	OFF
<i>ON</i>	ON
<i>RESMIN</i>	Select function: Reset MIN value with MP-Key – only when MIN value appears in the display
<i>OFF</i>	OFF
<i>ON</i>	ON
<i>RESMAX</i>	Select function: Reset MAX with MP-Key – only when MAX value appears in the display
<i>OFF</i>	OFF
<i>ON</i>	ON
<i>RESREL</i>	Select function Output-Latch Reset with MP-Key – only if output is in memory mode (ALARMx = LATCH)
<i>OFF</i>	OFF
<i>ON</i>	ON - this setting is possible only if all other settings are set to OFF
<i>RESTOT</i>	Select function Reset Totaliser with MP-Key – only if totaliser is in the display
<i>OFF</i>	OFF
<i>ON</i>	ON

9.4.2 Multifunction Inputs

<i>MPINP</i>	Menu Function MP-Inputs
<i>MPINP.1</i>	Select function MP-Input 1
<i>NOFUNC.</i>	No function
<i>RESMIN</i>	Reset MIN value
<i>RESMAX</i>	Reset MAX value
<i>RPEAKS</i>	Reset MIN and MAX values
<i>RESREL</i>	Reset Output-Latch - only if output is in memory mode (ALARMx = LATCH)
<i>DISPH.D</i>	Hold ('freeze') display
<i>LOCALR</i>	Lock-out limit value setting
<i>LOCPRG.</i>	Lock-out programming and default setting
<i>LOCKEY</i>	Lock-out limit value setting, programming, default setting and MP-Key
<i>TARA</i>	Tare
<i>RTARA</i>	Reset tare value
<i>RESTOT.</i>	Reset totaliser

<i>MPINP.2</i>	Select function MP-Input 2
<i>NOFUNC.</i>	No function
<i>RESMIN</i>	Reset MIN value
<i>RESMAX</i>	Reset MAX value
<i>RPEAKS</i>	Reset MIN and MAX values
<i>RESREL</i>	Reset Output-Latch - only if output is in memory mode (ALARMx = LATCH)
<i>DISPH.D</i>	Hold ('freeze') display
<i>LOCALR</i>	Lock-out limit value setting
<i>LOCPRG.</i>	Lock-out programming and default setting
<i>LOCKEY</i>	Lock-out limit value setting, programming, default setting and MP-Key
<i>TARA</i>	Tare
<i>RTARA</i>	Reset tare value
<i>RESTOT.</i>	Reset totaliser

9.5 Totaliser function

TOTAL	Menu Totaliser
CUT.OFF	Select value for low threshold cut-off
-199.999	Input value range -199999 ... +999999 and DP
FACTOR	Select value for multiplication factor
1.00000	Input value range 0.00001 ... 9.99999
SCALE	Select scale factor
x 1	Scale factor x 1 Scale factor x 0.1 Scale factor x 0.01 Scale factor x 0.001 Scale factor x 0.0001
DP.TOT.	Select decimal point for

	totaliser (optical function only)
0	0
0.0	0.0
0.00	0.00
0.000	0.000
0.0000	0.0000
0.00000	0.00000

The totaliser function captures the current (instantaneous) measured value every 100 msec. From these values the throughput rate per second is calculated. To convert the throughput rate into other units FACTOR and SCALE are available. Negative measured values are also taken into consideration. A decimal point that is programmed with a current measured value is not taken into consideration. The throughput rate is added into the totaliser memory every second. A dummy decimal point (optical indication only) can be programmed into the totaliser as required.

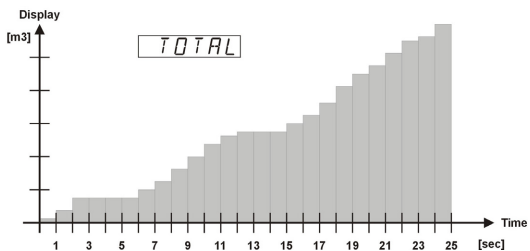
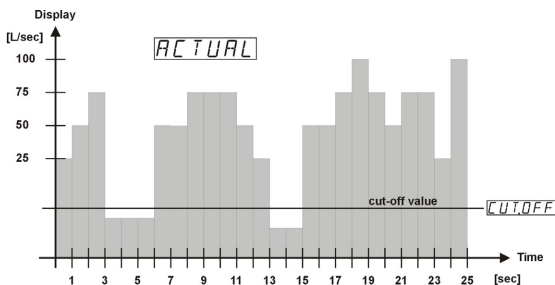

9.6 Limit Value (Alarm) Monitoring

ALARM1	Menu Alarm Output 1
ALOUT1	Select operating mode
OFF	OFF
AUTO	Automatic operation
LATCH	Memory latch operation - not with band limitation
ALLOC.1	Select source value for Alarm output 1
ACTUAL TOTAL	Current measured value Totaliser
MDOUT1	Select Output triggering
INCR	With incrementing measuring signal
DECR	With decrementing measuring signal
BAND	Band limitation
FMOUT1	Select Alarm status
---	With alarm: output active
7---	With alarm: output inactive
ONHYS.1	Select on-hysteresis
0.000	Input range 0 ... +9999 and DP
OFHYS.1	Select off-hysteresis - only with auto operation
0.000	Input range 0 ... +9999 and DP
ONJLY.1	Select on-delay
0.0	Input range 0.0 ... 99.9 [sec]
OFJLY.1	Select off-delay - only with auto operation
0.0	Input range 0.0 ... 99.9 [sec]
ALARM2	Menu Alarm Output 2
ALOUT2	Select operating mode
OFF	OFF
AUTO	Automatic operation
LATCH	Memory latch operation
ALLOC.2	Select source value for Alarm output 2
ACTUAL TOTAL	Current measured value Totaliser

MDOUT2	Select Output triggering
INCR	With incrementing measuring signal
DECR	With decrementing measuring signal
BAND	Band limitation
FMOUT2	Select Alarm status
---	With alarm: output active
7---	With alarm: output inactive
ONHYS.2	Select on-hysteresis
0.000	Input range 0 ... +9999 and DP
OFHYS.2	Select off-hysteresis - only with auto operation
0.000	Input range 0 ... +9999 and DP
ONJLY.2	Select on-delay
0.0	Input range 0.0 ... 99.9 [sec]
OFJLY.2	Select off-delay - only with auto operation
0.0	Input range 0.0 ... 99.9 [sec]

INCR
ON switching point = limit value + ON hysteresis
OFF switching point = limit value - OFF hysteresis

DECR
ON switching point = limit value - ON hysteresis
OFF switching point = limit value + OFF hysteresis

BAND
An alarm is triggered, if the measured value falls outside a defined range (Band).
Upper switching point = limit value + ON hysteresis
Lower switching point = limit value - OFF hysteresis

An alarm causes the output to become active (Relay energised, LED ON)

7---

An alarm causes the output to become inactive (Relay not energised, LED OFF)

PW.DELY. LATCH
In memory latch operation the status of the outputs is stored in the event of a Power OFF condition and then immediately restored at the next Power ON.

PW.DELY. AUTO
In auto operation the status of the outputs is not saved in the event of a Power OFF condition. At the next Power ON the limit values are not processed until after the expiration of the start delay (PW.DELY).

Control with incrementing measuring signal INCR

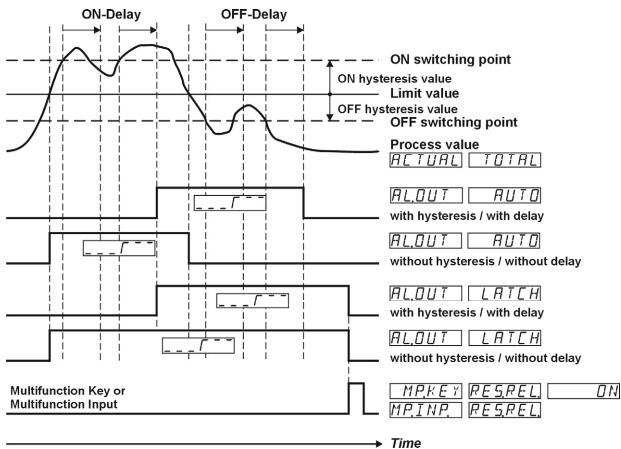

Control with decrementing measuring signal DECR

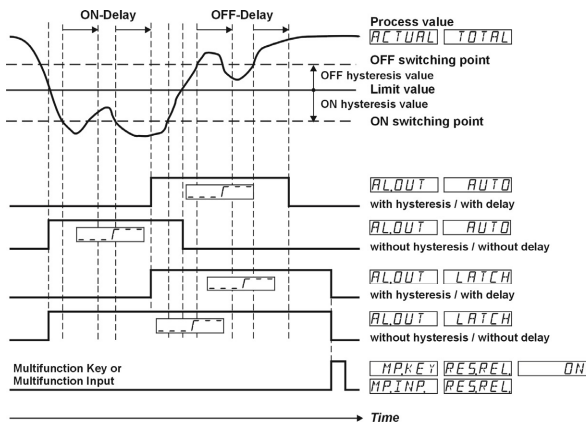

Control with Band Limitation

BAND

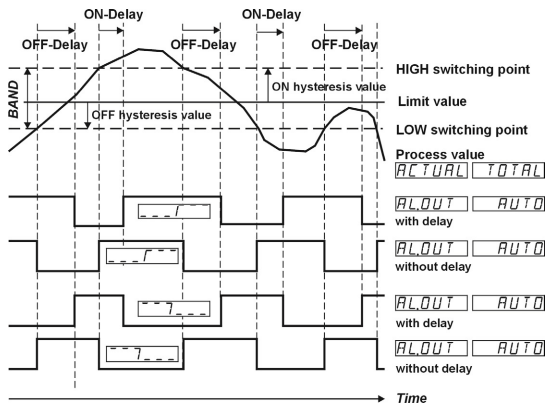

10 Monitoring of Measuring Circuit

Meas. range	Lower Display Range limit	Upper Display Range limit	Lower Meas. Range limit	Upper Meas. Range limit	Probe or wire short-circuit Probe or wire break
0 ... 10 V	DISP.LO	DISP.HI	LO.LIM	HIL.LIM	—
2 ... 10 V	■	■	■	■	■ (< 1 V)
-10 V/+10 V	■	■	■	■	—
0 ... 20 mA	■	■	■	■	—
4 ... 20 mA	■	■	■	■	■ (< 2 mA)
Indication	1.99999 blinking	9.99999 blinking	UNDERF. blinking	OVERFL. blinking	SENSOR blinking

(■ = is detected)

11 Technical Data

11.1 General Data

Display:	6-digit, 14 segment LED
Digit height:	14 mm
Data retention:	> 10 years, EEPROM
Operation:	5 keys

11.2 Measuring signal inputs

Sampling rate:	10 readings/sec
SELV circuits, reinforced / double insulation	

Voltage input

Progr. ranges:	0 ... 10 V, 2 ... 10 V, ± 10 V
Meas. range:	-10.5 ... +10.5 V
Resolution:	< 0.4 mV (±15Bit)
Meas. accuracy @ 23°C:	typ. 0.02 % of range max. ≤0.05 % of range
Temperature drift:	< 100 ppm/K
Input resistance:	1 MΩ
Max. voltage:	± 30 V

Current input

Progr. ranges:	0 ... 20 mA, 4 ... 20 mA
Measuring range:	-0.5 ... 21 mA
Resolution:	1 µA (> 14 Bit)
Measuring accuracy @ 23°C:	typ. 0.02 % of range max. ≤0.05 % of range
Temperature drift:	< 100 ppm/K
Input resistance:	22 Ω + PTC 25 Ω
Voltage drop:	ca. 1.8 V @ 20 mA
Max. current:	60 mA

11.3 Control Inputs MPI 1 / MPI 2

SELV circuits, reinforced / double insulation	
Quantity:	2, optocouplers
Function:	programmable
Switching levels:	Low: < 2 V High: > 4 V (max. 30 V)
Pulse length:	>100 ms

11.4 Alarm outputs

Relays:	changeover contacts
Prescribed fuse:	5A
Switching voltage:	max. 250 V AC / 125 V DC min. 5 V AC / V DC
Switching current:	max. 5 A AC / A DC min. 10 mA
Switching capacity:	max. 1250 VA / 150 W



The maximum values shall in no case be exceeded!

Mechanical service life (switching cycles) 1x10⁷

N° of switching cycles at 5 A / 250 V AC	5x10 ⁴
N° of switching cycles at 5 A / 30 V DC	5x10 ⁴

11.5 Supply voltage

AC supply:	100 ... 240 V AC / max. 9 VA 50 / 60 Hz, Tolerance ± 10% ext. fuse protection: T 0.1 A
DC supply:	10 ... 30 VDC / max. 3.5 W with galvanic isolation and, reverse polarity protection SELV, CLASS II (Limited Power Source) ext. fuse protection: T 0.4 A
Mains hum suppression:	50 Hz or 60 Hz, programmable

11.6 Sensor Supply voltage

(Voltage output for external sensors) SELV circuits, reinforced / double insulation at AC supply:	24 VDC ±15 %, 30 mA 15 VDC ±1 %, 25 mA
at DC supply:	15 VDC ±1 %, 25 mA

11.7 Climatic Conditions

Operating temperature:	-20°C ... +65°C
Storage temperature:	-25°C ... +75°C
Relative humidity:	R.H. 93 % at +40°C, non-condensing
Altitude:	up to 2000 m

11.8 EMC

Interference immunity:	with shielded signal and control lines not intended for local DC electricity supply network(s) / battery connecting cable ≥ 30 m
------------------------	----------------------------------------------------------------------------------------------------------------------------------

11.9 Device Safety

Protection Class:	Protection Class 2 (front side)
-------------------	---------------------------------



Only the front side is classified as accessible for the operator.

Application area:	Pollution level 2 over-voltage Category II
Insulation:	
Front:	double insulation
Rear side:	basic insulation
Signal inputs and und sensor power supply:	SELV

11.10 Mechanical Data

Housing:	Panel mount housing to DIN 43 700, RAL 7021
Dimensions:	96 x 48 x 102 mm
Panel cut-out:	92 ^{+0.8} x 45 ^{+0.6} mm
Installation depth:	approx. 92 mm incl. terminals
Weight:	approx. 180 g
Protection:	IP65 (front, device only)
Housing material:	Polycarbonate UL94 V-2

Vibration resistance: 10 - 55 Hz / 1 mm / XYZ
EN 60068-2-6 30 min in each direction

Shock resistance:
EN 60068-2-27 100G / XYZ
3 times in each direction
10G / 6 ms / XYZ
2000 times in each direction

11.11 Connections

Supply voltage and outputs:

Plug-in screw terminal, 8-pin, RM5.00
Core cross-section, max. 2.5 mm²

Signal and control inputs:

Plug-in screw terminal, 9-pin, RM 3.50
Core cross section, max. 1.5 mm²

12 Dimensional Drawings

Dimensions in mm [inch]

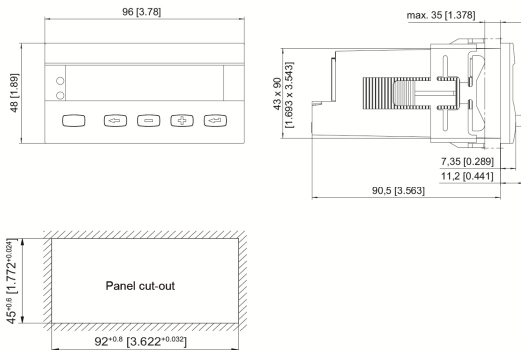

13 Help Texts

PROG.	NO	NO PROGRAMMING
PROG.	YES	START PROGRAMMING
HLP.TXT.		MAIN MENU SELECT HELPTTEXT
HLP.TXT.	ON	HELPTTEXTS ON
HLP.TXT	OFF	HELPTTEXTS OFF
SL.LANG.	DE	SPRACHE DEUTSCH
SL.LANG.	EN	LANGUAGE ENGLISH
INPUT.		MAIN MENU SIGNAL INPUT
RANGE	0-10V	VOLTAGE INPUT RANGE 0-10V
RANGE	2-10V	VOLTAGE INPUT RANGE 2-10V
RANGE	-10.10V	VOLTAGE INPUT RANGE -10V/+10V
RANGE	0-20MA	CURRENT INPUT RANGE 0-20MA
RANGE	4-20MA	CURRENT INPUT RANGE 4-20MA
LO.LIM.		LOWER INPUT RANGE LIMIT
HI.LIM.		UPPER INPUT RANGE LIMIT
DP.	0	NO DECIMAL POINT
DP.	0.0	DECIMAL POINT 0.0
DP.	0.00	DECIMAL POINT 0.00
DP.	0.000	DECIMAL POINT 0.000
DP.	0.0000	DECIMAL POINT 0.0000
DP.	0.00000	DECIMAL POINT 0.00000
INP.LO.		INPUT START VALUE
DISP.LO.		DISPLAY START VALUE
INP.HI.		INPUT END VALUE
DISP.HI.		DISPLAY END VALUE
FILTER		INPUT FILTER
PW.DELY.		POWER-ON DELAY FOR OUTPUTS [SEC]
PW.FREQ.	50HZ	POWER LINE FREQUENCY 50HZ
PW.FREQ.	60HZ	POWER LINE FREQUENCY 60HZ
LINEAR.		MAIN MENU LINEARIZATION
LINEAR.	NO	LINEARIZATION OFF
LINEAR.	YES	LINEARIZATION ON
NUM.PNT.		NUMBER OF LINEARIZATION POINTS
INP.01		INPUT VALUE NO.1
DISP.01		DISPLAY VALUE NO.1
to		
INP.10		INPUT VALUE NO.10
DISP.10		DISPLAY VALUE NO.10
MP.KEY		MAIN MENU MP-BUTTON
TARA	OFF	FUNCTION TARA OFF
TARA	ON	FUNCTION TARA ON
RES.MIN.	OFF	FUNCTION RESET MIN VALUE OFF
RES.MIN.	ON	FUNCTION RESET MIN VALUE ON
RES.MAX.	OFF	FUNCTION RESET MAX VALUE OFF
RES.MAX.	ON	FUNCTION RESET MAX VALUE ON
RES.REL.	OFF	FUNCTION RESET OUTPUT-LATCH OFF
RES.REL.	ON	FUNCTION RESET OUTPUT-LATCH ON
RES.TOT.	OFF	FUNCTION RESET TOTALIZER VALUE OFF
RES.TOT.	ON	FUNCTION RESET TOTALIZER VALUE ON

Your automation, our passion.

Explosion Protection

- Intrinsic Safety Barriers
- Signal Conditioners
- FieldConnex® Fieldbus
- Remote I/O Systems
- Electrical Ex Equipment
- Purge and Pressurization
- Industrial HMI
- Mobile Computing and Communications
- HART Interface Solutions
- Surge Protection
- Wireless Solutions
- Level Measurement

Industrial Sensors

- Proximity Sensors
- Photoelectric Sensors
- Industrial Vision
- Ultrasonic Sensors
- Rotary Encoders
- Positioning Systems
- Inclination and Acceleration Sensors
- Fieldbus Modules
- AS-Interface
- Identification Systems
- Displays and Signal Processing
- Connectivity

Pepperl+Fuchs Quality
Download our latest policy here:

www.pepperl-fuchs.com/quality



Weltweit

Pepperl+Fuchs SE
Lilienthalstraße 200
68307 Mannheim
Deutschland
Telefon: +49 621 776-0
E-Mail: info@de.pepperl-fuchs.com
<https://www.pepperl-fuchs.com>

Änderungen vorbehalten · © Pepperl+Fuchs
Printed in Germany
DOCT-2856C
R60361.9465 - Index 5 · 11/2023