

MFT-***.****(.L)

Multifunction Terminal

Manual

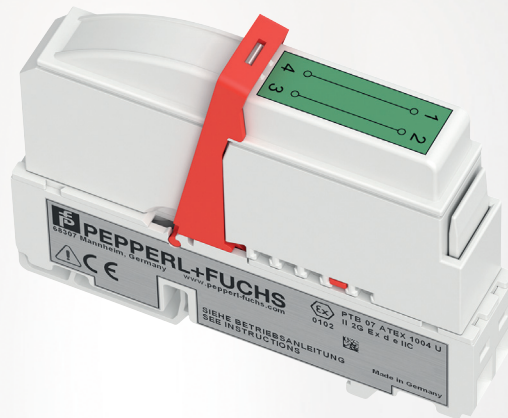

Your automation, our passion.

 **PEPPERL+FUCHS**

With regard to the supply of products, the current issue of the following document is applicable:
The General Terms of Delivery for Products and Services of the Electrical Industry, published by the Central Association of the Electrical Industry (Zentralverband Elektrotechnik und Elektroindustrie (ZVEI) e.V.) in its most recent version as well as the supplementary clause: "Expanded reservation of proprietorship"

Worldwide

Pepperl+Fuchs Group
Lilienthalstr. 200
68307 Mannheim
Germany
Phone: +49 621 776 - 0
E-mail: info@de.pepperl-fuchs.com

North American Headquarters

Pepperl+Fuchs Inc.
1600 Enterprise Parkway
Twinsburg, Ohio 44087
USA
Phone: +1 330 425-3555
E-mail: sales@us.pepperl-fuchs.com

Asia Headquarters

Pepperl+Fuchs Pte. Ltd.
P+F Building
18 Ayer Rajah Crescent
Singapore 139942
Phone: +65 6779-9091
E-mail: sales@sg.pepperl-fuchs.com
<https://www.pepperl-fuchs.com>

1	Introduction	5
1.1	Content of this Document	5
1.2	Target Group, Personnel	6
1.3	Symbols Used	6
2	Product Specifications	7
2.1	Function	7
2.2	Assembly	8
2.3	Dimensions	9
2.4	Marking	10
2.5	Technical Data	10
3	Installation	11
3.1	Mounting	12
3.2	Connecting the Plug-In Module	13
3.3	Connection	14
4	Commissioning	16
4.1	Coding	16
5	Dismounting, Maintenance, and Repair	17
5.1	Removing Plug-In Modules	18
5.2	Dismounting	19
6	Storage, Transport, and Disposal	21

1 Introduction

1.1 Content of this Document

This document contains information that you need in order to use your product throughout the applicable stages of the product life cycle. These can include the following:

- Product identification
- Delivery, transport, and storage
- Mounting and installation
- Commissioning and operation
- Maintenance and repair
- Troubleshooting
- Dismounting
- Disposal



Note

This document does not substitute the instruction manual.



Note

For full information on the product, refer to the instruction manual and further documentation on the Internet at www.pepperl-fuchs.com.

The documentation consists of the following parts:

- Present document
- Instruction manual
- Datasheet

Additionally, the following parts may belong to the documentation, if applicable:

- EU-type examination certificate
- EU declaration of conformity
- Attestation of conformity
- Certificates
- Control drawings
- Additional documents

1.2 Target Group, Personnel

Responsibility for planning, assembly, commissioning, operation, maintenance, and dismantling lies with the plant operator.

Only appropriately trained and qualified personnel may carry out mounting, installation, commissioning, operation, maintenance, and dismantling of the product. The personnel must have read and understood the instruction manual and the further documentation.

Prior to using the product make yourself familiar with it. Read the document carefully.

1.3 Symbols Used

This document contains symbols for the identification of warning messages and of informative messages.

Warning Messages

You will find warning messages, whenever dangers may arise from your actions. It is mandatory that you observe these warning messages for your personal safety and in order to avoid property damage.

Depending on the risk level, the warning messages are displayed in descending order as follows:



Danger!

This symbol indicates an imminent danger.

Non-observance will result in personal injury or death.



Warning!

This symbol indicates a possible fault or danger.

Non-observance may cause personal injury or serious property damage.



Caution!

This symbol indicates a possible fault.

Non-observance could interrupt the device and any connected systems and plants, or result in their complete failure.

Informative Symbols



Note

This symbol brings important information to your attention.



Action

This symbol indicates a paragraph with instructions. You are prompted to perform an action or a sequence of actions.

2 Product Specifications

2.1 Function

Many applications in hazardous areas work with field devices that do not have intrinsically safe connections. In these applications, protection methods such as type Ex e protection (increased safety) are used. In contrast to intrinsically safe circuits, increased safety connections are generally not accessible when energized. Disconnecting these circuits for maintenance would therefore require either the plant to be shut down or a hot work permit to be obtained.

The multifunction terminal offers the following options for disconnecting non-intrinsically safe circuits or removing plug-in modules in hazardous areas:

- The multifunction terminals MFT-R.****, MFT-2R.****, MFT-D****(.L), MFT-2D.****, MFT-F.****(.L), MFT-2F.****, MFT-2L.**** enable the non-intrinsically safe circuits to be disconnected.
- The multifunction terminals MFT-FT.****, MFT-RNO.****, MFT-RNC.**** enable the plug-in modules to be removed even in hazardous areas.

The non-intrinsically safe circuits are separated in 2 steps:

- **Step 1**
The electrical contacts between the base module and the plug-in module are separated in areas protected by the type of protection Ex d. In this position the sparks, that have formed within the contact area, can no longer ignite the possibly existing surrounding atmosphere.
- **Step 2**
The plug-in module, which is now completely electrically isolated, can now be removed. Possible ignition sources in the area of the electrical contacts are no longer present. The electrical connections of the base module are protected and comply with degree of protection IP30 according to IEC/EN 60529. After removal, the plug-in module is de-energized.
- Once the plug-in module has been removed, the de-energized side is accessible. This allows field devices that are connected to the de-energized side to be replaced, while the remaining part of the system continues to be energized.

Typical applications for the multifunction terminal are:

- Fusing Ex d valves, signal lamps, acoustic sensors
- Diode decoupling of supply circuits
- Simple OR gate for Zone 1 mounting
- Visible disconnect of field devices
- Relay switch for power circuits
- Current limitation using resistors
- Optocoupler applications

2.2 Assembly

The multifunction terminal consists of a base module and a plug-in module. The base module is mounted on a DIN mounting rail. The plug-in module is connected to the base module.

The base module has a plastic housing that conforms to type of protection Ex e.

There are 2-pin and 4-pin base modules for connecting plug-in modules with 2 or 4 pins.

The plug-in module has a plastic housing with type of protection Ex d. The plug-in module has pins. The pins form together with the plug-in module contacts a chamber in type of protection Ex d.

The plug-in module can be equipped with various components, such as resistors, diodes, fuses, or relays. The plug-in module can be removed or connected during operation. Grooves of different widths ensure that the plug-in module is connected to the base module correctly.

A coding strip in the base module and corresponding coding pins in the plug-in module enable clear assignment of the plug-in modules to the base module.

Screw terminals and unused terminal openings can be covered with IP30 covers in the form of terminal covers and terminal pins, so that no bare, conductive parts are left uncovered. These covers will be fitted during installation and must not be removed during operation.

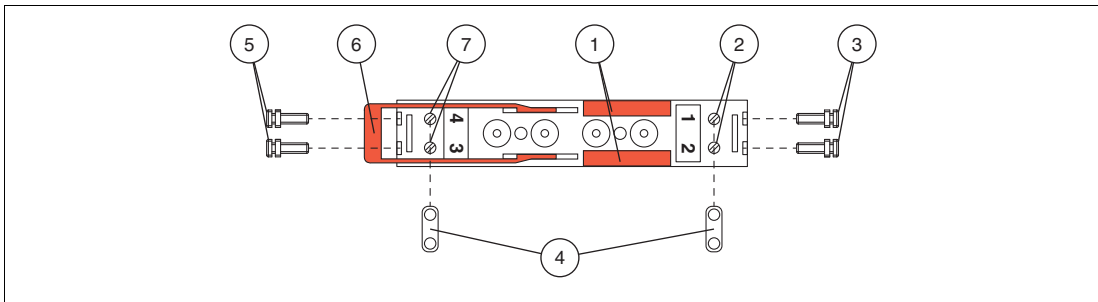

Figure 2.1 Base module, view from above

- 1 Coding strips
- 2 Screw terminals with steel screw M3
- 3 Terminal pins for unused Ex e terminals, IP30 protection
- 4 Terminal covers for IP30 protection
- 5 Terminal pins for unused Ex e terminals, IP30 protection
- 6 Lever for locking and unlocking the multifunction terminal
- 7 Screw terminals with steel screw M3

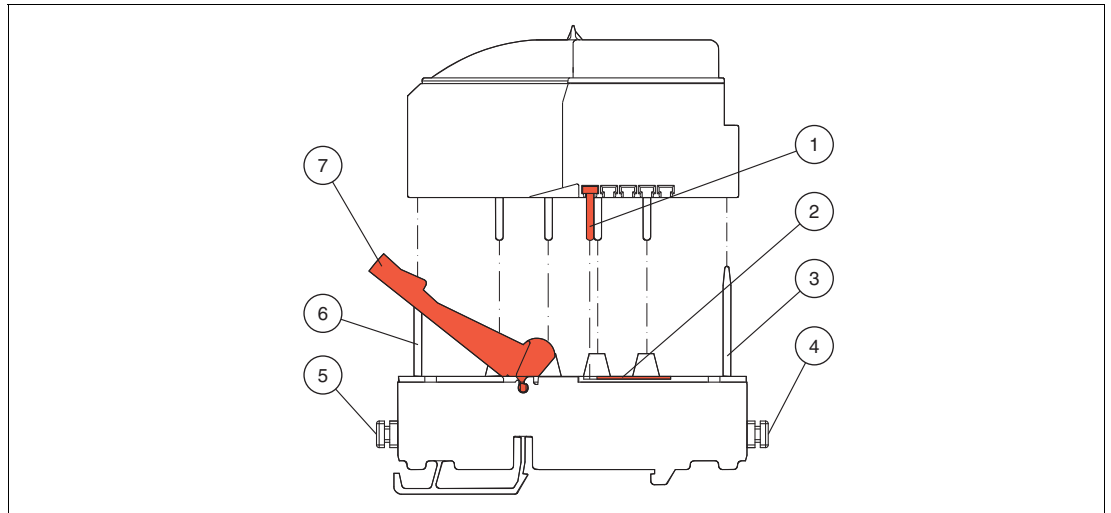

Figure 2.2 Base module and plug-in module, side view

- 1 Coding pin
- 2 Coding strip
- 3 Wide groove
- 4 Terminal pins for unused Ex e terminals, IP30 protection
- 5 Terminal pins for unused Ex e terminals, IP30 protection
- 6 Narrow groove
- 7 Lever for locking and unlocking the multifunction terminal

2.3 Dimensions

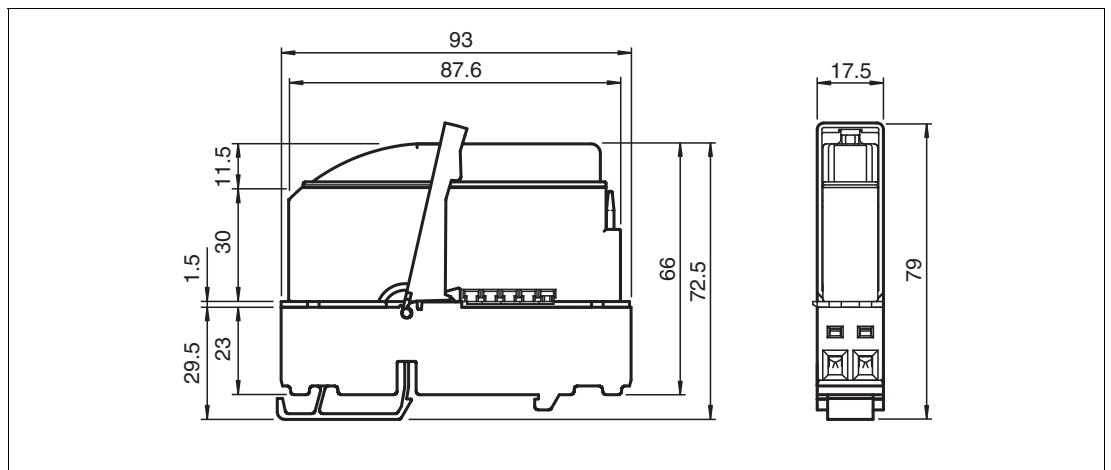



Figure 2.3 Dimensions multifunction terminal

2.4 Marking

Base module	
2-pin	MFT-BASE.2P
4-pin	MFT-BASE.4P
Plug-in module	
1 resistor	MFT-R.0001 ... MFT-R.9999
2 resistors	MFT-2R.0001 ... MFT-2R.9999
1 diode	MFT-D.1000
2 diodes	MFT-2D.0500
1 diode, 1 bridge	MFT-D.1000.L
2 bridges	MFT-2L.1600
1 bridge, 1 fuse	MFT-F.0032.L ... MFT-F.6300.L
1 fuse	MFT-F.0032 ... MFT-F.6300
2 fuses	MFT-2F.0032 ... MFT-2F.6300
Terminator	MFT-FT.0001
NO contact	MFT-RNO.0006
NC contact	MFT-RNC.0006
ATEX certificate: PTB 07 ATEX 1004 U ATEX marking:  II 2 G Ex d e IIC	
IECEX certificate: BKI 08.0008U IECEX marking: Ex d e IIC Gb	
Pepperl+Fuchs Group Lilienthalstraße 200, 68307 Mannheim, Germany	
Internet: www.pepperl-fuchs.com	

2.5 Technical Data



Note

See corresponding datasheets for further information.

3 Installation



Danger!

Explosion hazard from pollution

Pollution generates creepage paths, such that the insulation distances are no longer sufficient. As a result, the device loses its type of protection and can ignite a surrounding explosive atmosphere.

Ensure that you install the device only in environments with a pollution degree 2 or better in accordance with IEC/EN 60664-1.



Danger!

Explosion hazard from wrong mounting

The device safety can be impaired by external environmental influences and by mechanical stress. That can lead to sparking that can ignite a surrounding potentially explosive atmosphere.

Mount the device in a surrounding enclosure that complies with the requirements for surrounding enclosures according to IEC/EN 60079-0 and that is rated with the degree of protection IP54 according to IEC/EN 60529. The surrounding enclosure have to comply the respective requirements for explosion-hazardous areas.



Danger!

Explosion hazard from missing cover

If non-intrinsically safe circuits come into contact with electrically conductive objects, a spark can occur that can ignite an explosive mixture.

- Protect the non-intrinsically safe circuits with a cover that is rated with the degree of protection IP30 according to IEC/EN 60529.
- Use the supplied parts to ensure the required degree of protection.
- Place warning marking "Warning – Non-intrinsically safe circuits protected by internal cover with a degree of protection IP30!" visibly next to base module.

Requirements for Equipment Protection Level Gb



Danger!

Explosion hazard from environmental influences that impair the type of protection

External environmental influences can impair the type of protection of the devices. This impairments can lead to sparks or impermissible heat that ignites the surrounding explosive atmosphere.

Mount the device in a surrounding enclosure that complies with the requirements for surrounding enclosures according to IEC/EN 60079-0, and that is rated with the degree of protection IP54 according to IEC/EN 60529. The surrounding enclosure must have an EU declaration of conformity according to the ATEX Directive for at least equipment protection level Gb.

Requirements for Equipment Protection Level Gc



Danger!

Explosion hazard from environmental influences that impair the type of protection

External environmental influences can impair the type of protection of the devices. This impairment can lead to sparks or impermissible heat that ignites the surrounding explosive atmosphere.

Mount the device in a surrounding enclosure that complies with the requirements for surrounding enclosures according to IEC/EN 60079-0, and that is rated with the degree of protection IP54 according to IEC/EN 60529. The surrounding enclosure must have an EU declaration of conformity according to the ATEX Directive for at least equipment protection level Gc.

3.1

Mounting



Danger!

Explosion hazard from sparking by contact

If non-intrinsically safe circuits come into contact with electrically conductive objects, this may cause sparks, which can ignite an explosive mixture.

- Make sure that the atmosphere is not potentially explosive.
- Make sure that the current circuits are de-energized and potential-free.
- Do not touch any energized parts.

The multifunction terminal is mounted on a 35 mm DIN mounting rail according to EN 60715.

Mounting the Multifunction Terminal



1. Hook the multifunction terminal into the DIN mounting rail with the rear hook.

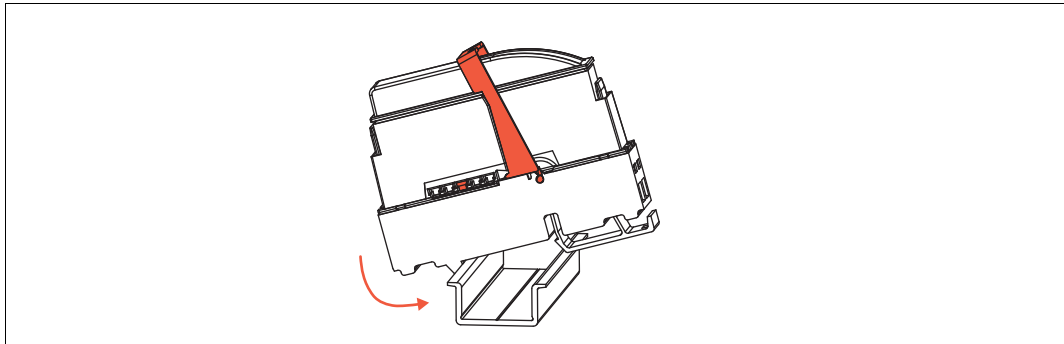

2. Press the multifunction terminal onto the DIN mounting rail so that the front hook engages with an audible click.

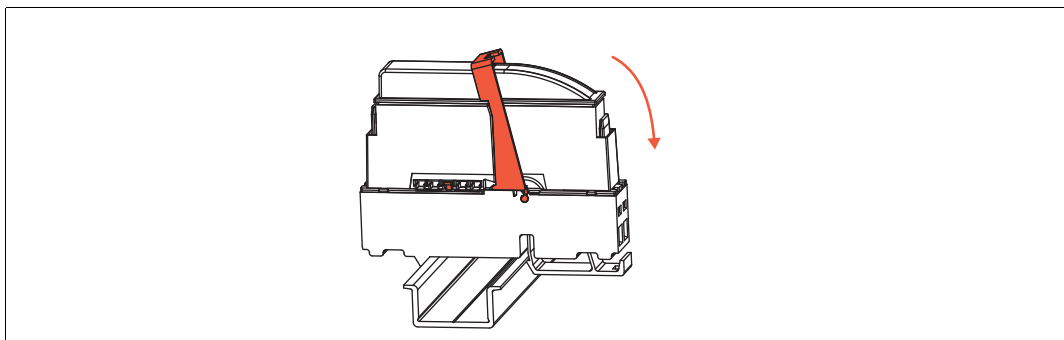

2020-03

3.2 Connecting the Plug-In Module

Plug-in modules can be connected during operation.



Connecting the Plug-In Module

1. Move the lever of the base module forward until it stops. Note that you cannot move the lever forward completely.

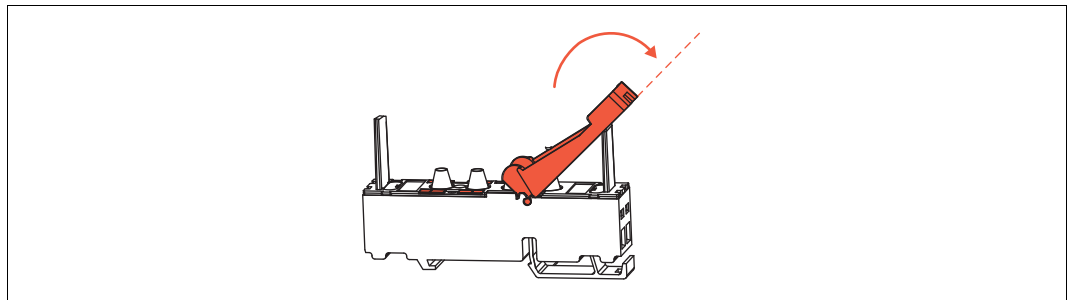

2. Press the lever of the base module forward until it stops. Guide the plug-in module onto the grooves of the base module.

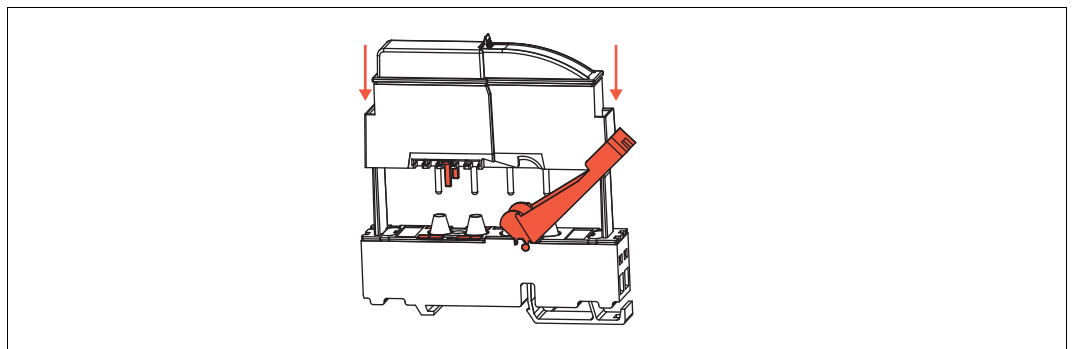

3. Press the plug-in module onto the base module and push the lever over the plug-in module until it engages.

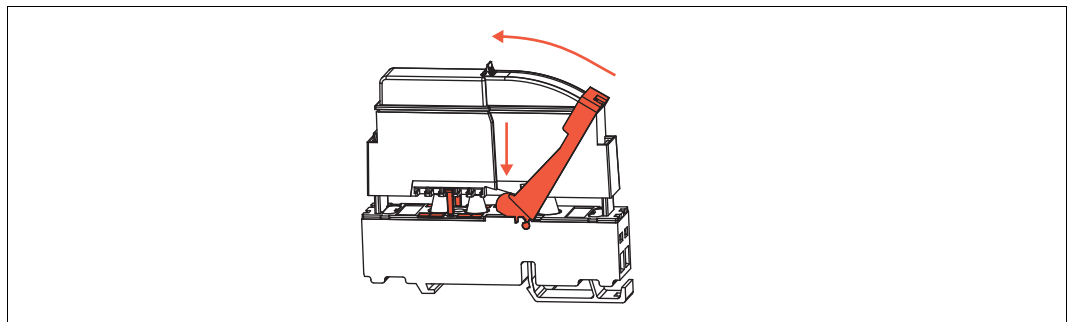

↳ The contacts between the base module and the plug-in module are connected with one another.

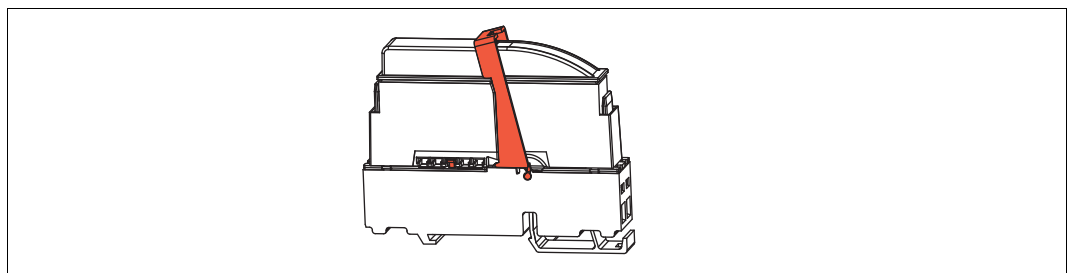

3.3 Connection



Danger!

Danger to life from incorrect installation

Incorrect installation of cables and connection lines can compromise the function and the electrical safety of the device.

- Observe the permissible core cross section of the conductor.
- When using stranded conductors, crimp wire end ferrules on the conductor ends.
- Use only one conductor per terminal.
- When installing the conductors the insulation must reach up to the terminal.
- Observe the tightening torque of the terminal screws.



Danger!

Explosion hazard from missing cover

Contact with bare parts that are energized can cause sparks, which can ignite an explosive mixture.

Make sure that all bare, conductive parts are fitted with a cover that is rated with the degree of protection IP30 according to IEC/EN 60529. Make sure that screw terminals have terminal covers and unused terminal openings have terminal pins.

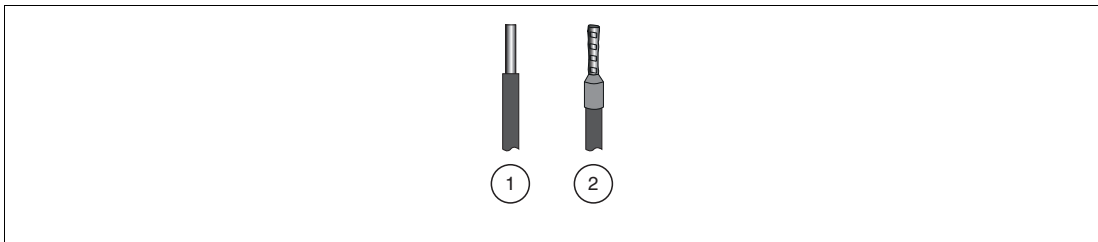

Figure 3.1

- 1 Wire
- 2 Stranded conductor with wire end ferrule

The connections on the multifunction terminal are suitable for core cross-sections of between 0.5 mm^2 and 2.5 mm^2 .



Connecting Multifunction Terminals

1. Remove the insulation from the conductors to a length of 9 mm.
2. If you are using stranded conductors, make sure that these are fitted with wire end ferrules.
3. Insert the conductors in the opening of the multifunction terminal. Note that the conductor insulation must reach up to the terminal.
4. Make sure to use separation intervals between current circuits according to IEC/EN 60079-14.
5. Tighten all the screws on the screw terminals to a tightening torque of 0.5 Nm to 0.9 Nm. This is valid for unused terminal openings too.

6. To ensure IP30 protection, fit terminal covers over the screws.

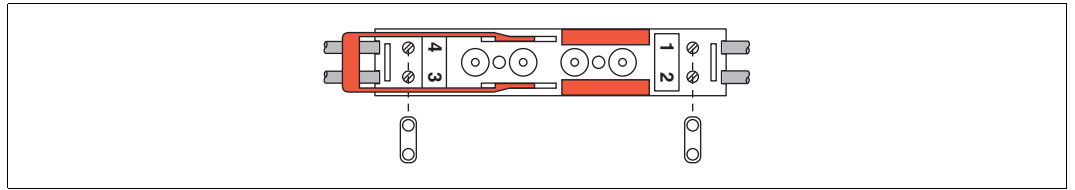

↳ The bare parts of the screws are covered.

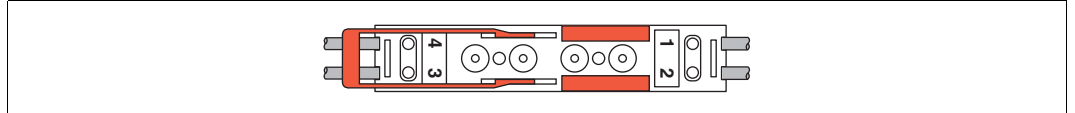

7. Place warning marking "Warning – Non-intrinsically safe circuits protected by cover with a degree of protection IP30!" visibly next to base module.

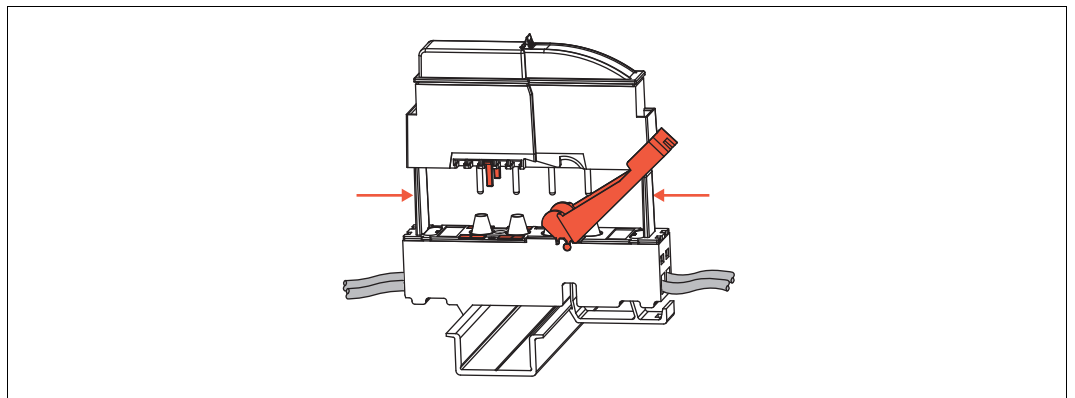

8. To ensure IP30 protection, close unused terminal openings with terminal pins.

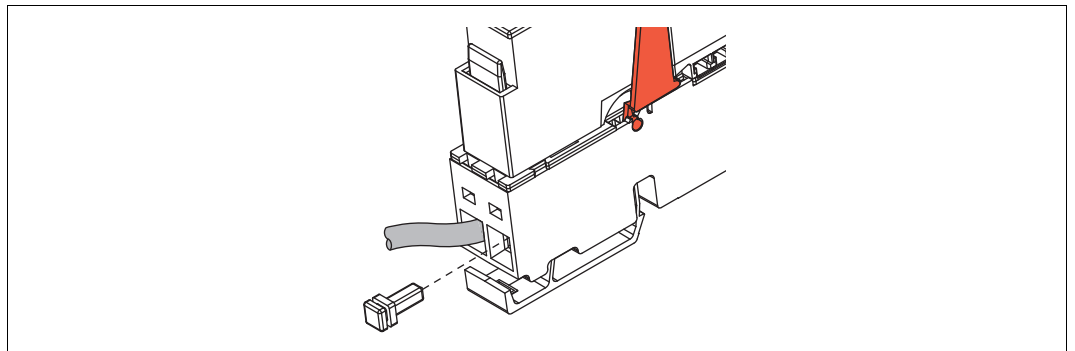

↳ Unused terminal openings are closed.

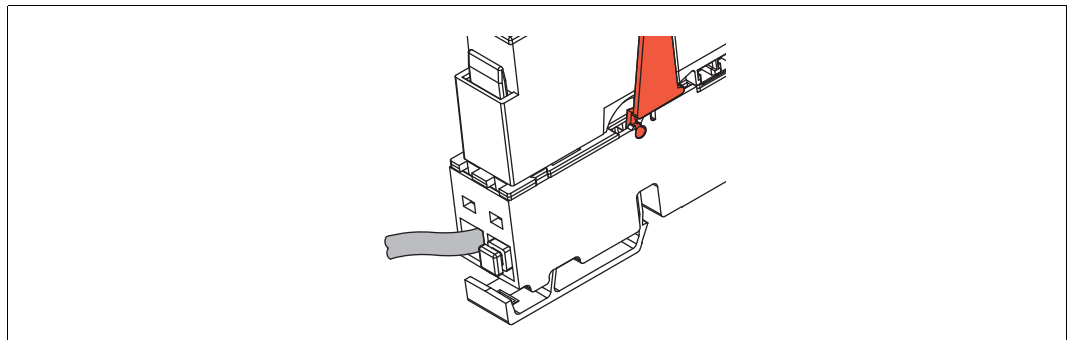

4 Commissioning

4.1 Coding



Caution!

Property damage from wrong coding

If the coding is not unique, plug-in modules can be accidentally swapped.

Coding the plugin modules uniquely so that every plug-in module fits exactly one base module.

Use the coding strip in the base module and corresponding coding pins in the plug-in module to enable unique assignment of plug-in modules to base modules.



Coding Multifunction Terminals

1. Shorten the coding strip of the base module to create one or more openings for coding pins.

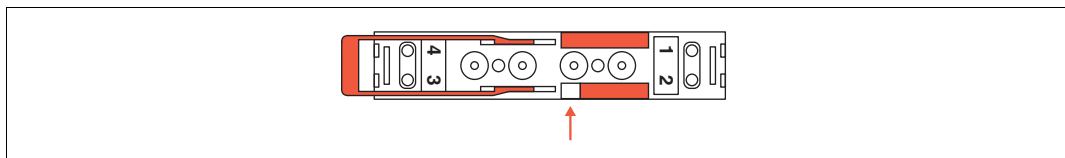

2. For each opening in the base module, insert a coding pin in the opposite side of the respective plug-in module.

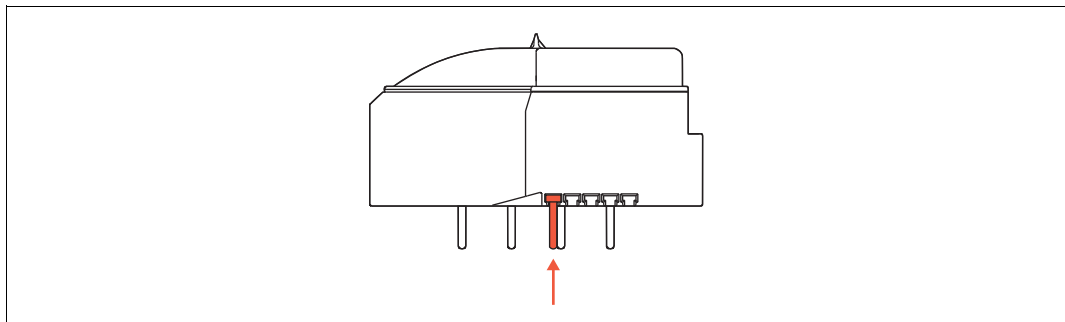

Note that the coding in example 1 and example 2 is not unique. The plug-in module from example 1 could be accidentally connected to the base module from example 2. In contrast, the coding in example 1 and example 3 is unique.

	Example 1	Example 2	Example 3
Plug-in module			
Base module			

Table 4.1

5 Dismounting, Maintenance, and Repair



Danger!

Danger to life from using damaged or repaired devices.

Using a defective or repaired device can compromise its function and its electrical safety.

- Do not use a damaged or polluted device.
 - The device must not be repaired, changed or manipulated.
 - If there is a defect, always replace the device with an original device from Pepperl+Fuchs.
-



Danger!

Explosion hazard from contact with potentially explosive atmosphere

When working in hazardous areas, there is an explosion hazard from sparking. The sparks can ignite the surrounding explosive atmosphere.

- Only open the surrounding enclosure in the hazardous area, if the non-intrinsically safe circuits are protected by a cover with a degree of protection IP30 according to IEC/EN 60529.
 - Only remove the plug-in module in the hazardous area, if the non-intrinsically safe circuits are protected by a cover with a degree of protection IP30 according to IEC/EN 60529.
-



Danger!

Explosion hazard from missing cover

If non-intrinsically safe circuits come into contact with electrically conductive objects, a spark can occur that can ignite an explosive mixture.

- Protect the non-intrinsically safe circuits with a cover that is rated with the degree of protection IP30 according to IEC/EN 60529.
 - Use the supplied parts to ensure the required degree of protection.
 - Place warning marking "Warning – Non-intrinsically safe circuits protected by internal cover with a degree of protection IP30!" visibly next to base module.
-

The national requirements apply to maintenance, servicing, and inspection of associated apparatus.

No maintenance is necessary if the devices are operated properly, observing the mounting instructions and ambient conditions.

5.1 Removing Plug-In Modules

Plug-in modules may be removed during operation.



Removing Plug-In Modules

1. Push the lever above the plug-in module forward, into position 1. Note that the lever cannot be pushed all the way forward.

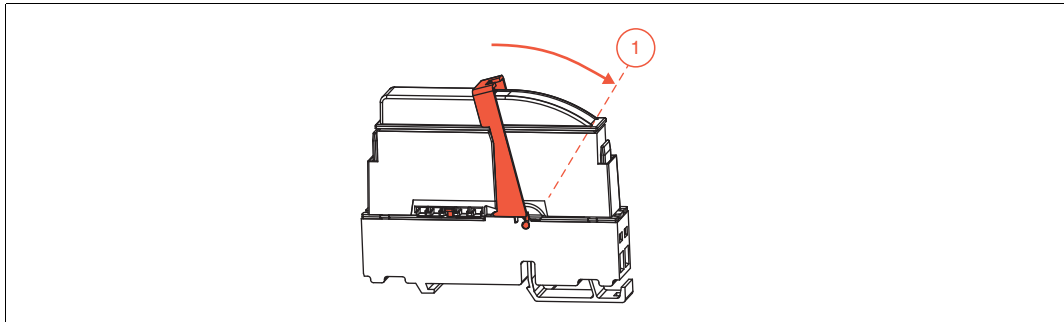

↳ The plug-in module is raised out of the base module. This separates the contacts between the base module and the plug-in module.

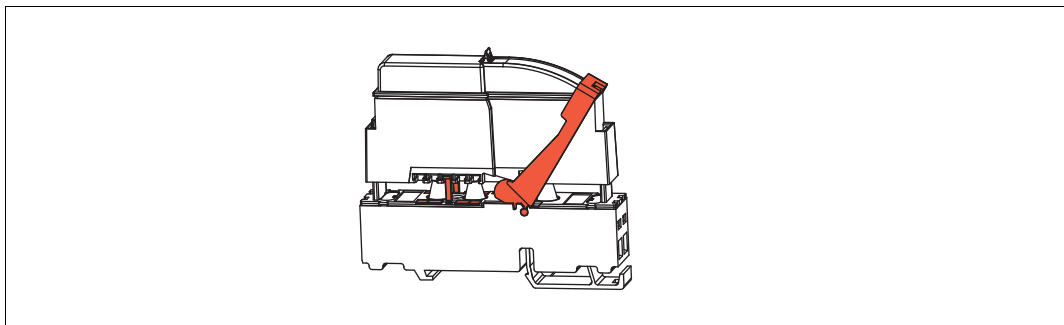

2. Push the lever forward a little farther, into position 2, and remove the plug-in module.

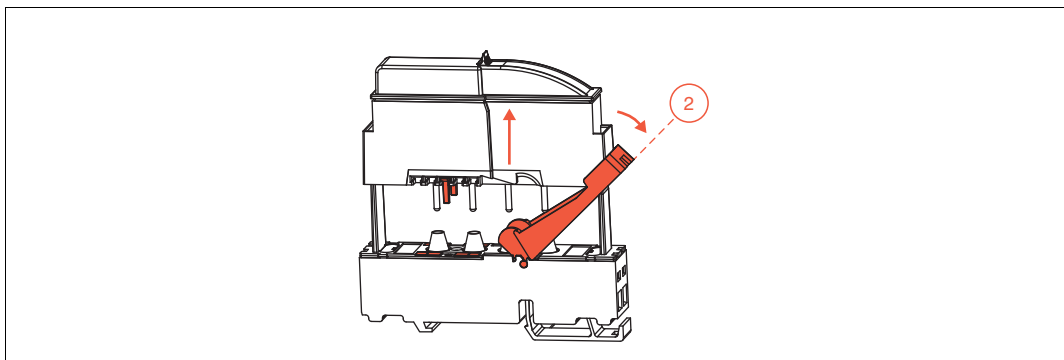

5.2 Dismounting



Danger!

Explosion hazard from sparking by contact

If non-intrinsically safe circuits come into contact with electrically conductive objects, this may cause sparks, which can ignite an explosive mixture.

- Make sure that the atmosphere is not potentially explosive.
- Make sure that the current circuits are de-energized and potential-free.
- Do not touch any energized parts.

To dismount the multifunction terminal from the DIN mounting rail, you will need a screwdriver.



Dismounting the Multifunction Terminal

1. Insert the screwdriver into the front hook of the terminal device.

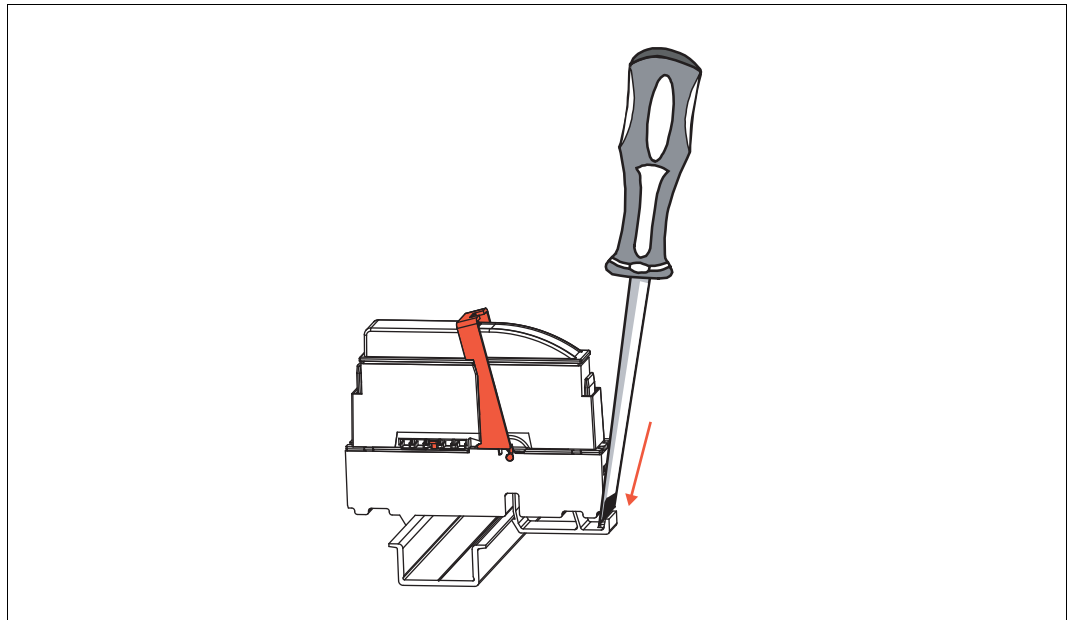

2. Carefully press the screwdriver backward so that the terminal device is pulled forward and releases from the DIN mounting rail.

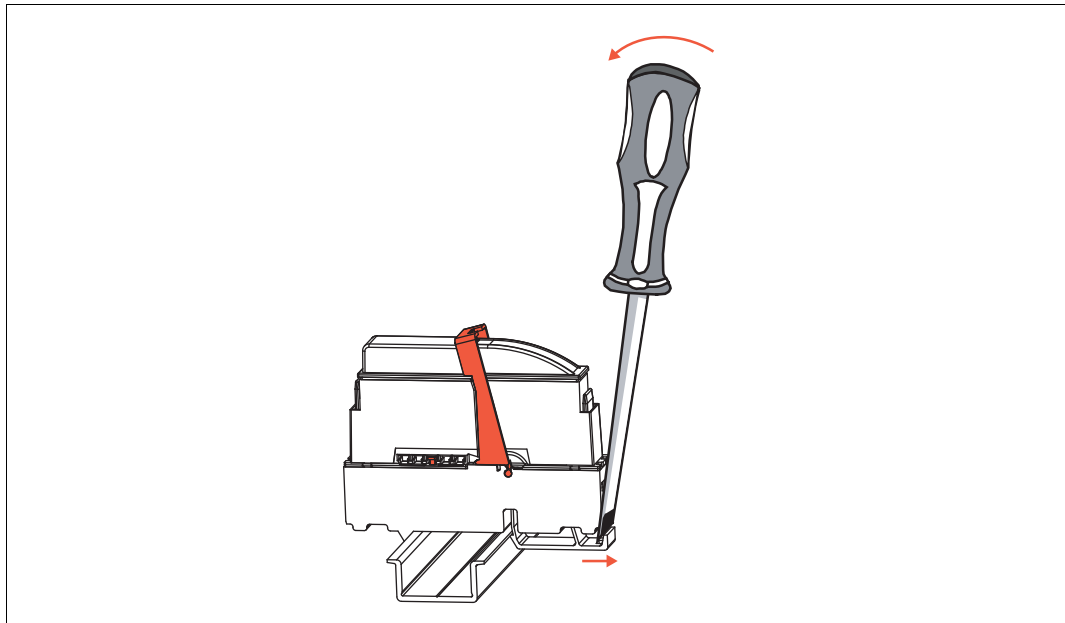

3. Release the rear hook of the multifunction terminal from the DIN mounting rail.

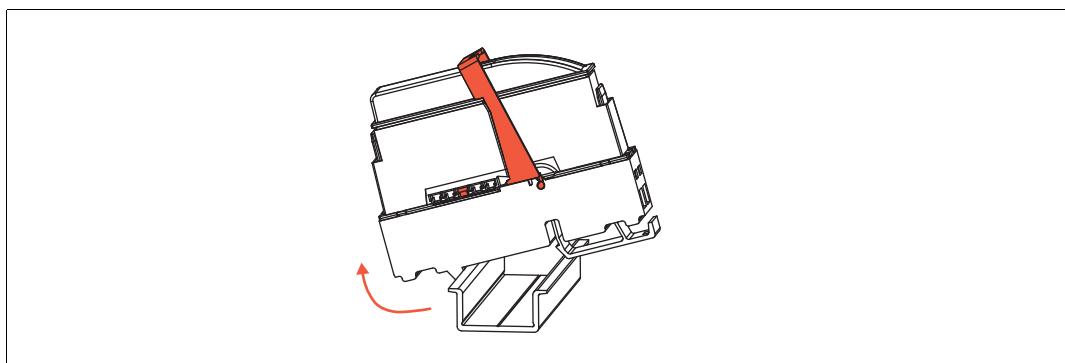

6 Storage, Transport, and Disposal

Keep the original packaging. Always store and transport the device in the original packaging.

Store the device in a clean and dry environment. The permitted ambient conditions must be considered, see datasheet.

The device, built-in components, packaging, and any batteries contained within must be disposed in compliance with the applicable laws and guidelines of the respective country.

Your automation, our passion.

Explosion Protection

- Intrinsic Safety Barriers
- Signal Conditioners
- FieldConnex® Fieldbus
- Remote I/O Systems
- Electrical Ex Equipment
- Purge and Pressurization
- Industrial HMI
- Mobile Computing and Communications
- HART Interface Solutions
- Surge Protection
- Wireless Solutions
- Level Measurement

Industrial Sensors

- Proximity Sensors
- Photoelectric Sensors
- Industrial Vision
- Ultrasonic Sensors
- Rotary Encoders
- Positioning Systems
- Inclination and Acceleration Sensors
- Fieldbus Modules
- AS-Interface
- Identification Systems
- Displays and Signal Processing
- Connectivity

Pepperl+Fuchs Quality

Download our latest policy here:

www.pepperl-fuchs.com/quality

