

MANUAL

FieldBarrier R4D0-FB-IA*

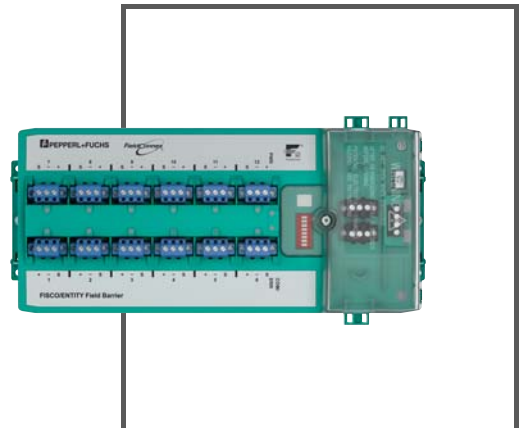



With regard to the supply of products, the current issue of the following document is applicable: The General Terms of Delivery for Products and Services of the Electrical Industry, published by the Central Association of the Electrical Industry (Zentralverband Elektrotechnik und Elektroindustrie (ZVEI) e.V.) in its most recent version as well as the supplementary clause: "Expanded reservation of proprietorship"

1	Safety	5
1.1	Validity.....	5
1.2	Symbols used.....	5
1.3	System Operator and Personnel	5
1.4	Pertinent Laws, Standards, Directives, and further Documentation	5
1.5	Marking	6
1.6	Intended Use	6
1.7	Improper Use.....	6
1.8	Mounting and Installation.....	6
1.8.1	Intrinsically Safe Circuits	8
1.9	Repair and Maintenance.....	8
1.10	Delivery, Transport and Storage	8
1.11	Disposal	9
2	Product Specifications.....	10
2.1	Overview and Application	10
2.2	Component Identity	12
2.3	Technical Data R4D0-FB-IA*	13
3	Installation and Commissioning	17
3.1	Mounting and Dismounting.....	17
3.2	FieldBarrier Attaching/Detaching the IP30 Trunk Connection Cover	20
3.3	DIP-Switch Physical Layer Diagnostics Configuration	21
3.4	Terminal Connections.....	23
3.4.1	FieldBarrier Trunk Connection	23
3.4.2	FieldBarrier Spur Connections.....	25
3.5	Grounding/Shielding	26
3.5.1	Grounding/Shielding the Spurs	26
3.5.2	Grounding/Shielding the Trunk Cable	27
3.5.3	Grounding the FieldBarrier.....	29

3.6	Trunk Termination	31
4	Operation	33
4.1	Indicators	33
4.2	Current Management of the Spurs	34
4.3	Spur Noise	34
4.4	Fault Detection, Physical Layer Diagnostics	34
4.4.1	Device Signal Level	35
4.4.2	Device Signal Jitter.....	35
4.5	Fault Isolation	35
4.5.1	FieldBarrier Self-Diagnostics.....	35
4.5.2	Short Circuit Current Limitation (Static Fault Protection)	35
4.5.3	Spur Contact Bounce Protection (Dynamic Fault Protection)	35
4.5.4	Progressive Spur Short Circuit Current Limitation (Creeping Fault Protection).....	36
4.5.5	Device Jabber Protection	36
4.6	Surge Protection	36
4.7	Accessory: Enclosure Leakage Sensor ELS-1	37
4.8	Using Device Couplers in PROFIBUS PA Installations	38
4.9	Using Device Couplers in FOUNDATION Fieldbus H1 Installations	38
5	Appendix	40
5.1	Ordering Information	40
5.2	Electromagnetic Compatibility Verification in Accordance with EC Council Legislation Directive 2004/108/EC	40

1 Safety

1.1 Validity

The chapter "Safety" is valid as instruction manual.

Specific processes and instructions in this document require special precautions to guarantee the safety of the operating personnel.

1.2 Symbols used

This document contains information that you must read for your own personal safety and to avoid property damage. Depending on the hazard category, the warning signs are displayed in descending order as follows:

Safety-relevant symbols



Danger!

This symbol indicates an imminent danger.

Non-observance will result in personal injury or death.



Warning!

This symbol indicates a possible fault or danger.

Non-observance may cause personal injury or serious property damage.



Caution!

This symbol indicates a possible fault.

Non-observance could interrupt devices and any connected facilities or systems, or result in their complete failure.

Informative symbols



Note!

This symbol brings important information to your attention.



Action

This symbol indicates a paragraph with instructions.

1.3 System Operator and Personnel

Responsibility for planning, assembly, commissioning, operation, maintenance, and dismounting lies with the system operator.

Mounting, installation, commissioning, operation, maintenance and disassembly of any devices may only be carried out by trained, qualified personnel. The instruction manual must be read and understood.

1.4 Pertinent Laws, Standards, Directives, and further Documentation

Laws, standards, or directives applicable to the intended use must be observed. In relation to hazardous areas, Directive 1999/92/EC must be observed.



The corresponding data sheets, declarations of conformity, EC-type-examination certificates, certificates and Control Drawings if applicable (see data sheet) are an integral part of this document. You can find this information under www.pepperl-fuchs.com.

Due to constant revisions, documentation is subject to permanent change. Please refer only to the most up-to-date version, which can be found under www.pepperl-fuchs.com.

1.5 Marking

The R4D0-FB-IA**.*.**** is marked with:

Pepperl+Fuchs GmbH
68307 Mannheim /Germany
R4D0-FB-IA**.*.****

BVS 13 ATEX E 121 X	IECEX BVS 13.0119X
 II 2 (1)G Ex e ib mb [ia Ga] IIC T4 Gb ,  II 2 G (1D) Ex e ib mb [ia IIIC Da] IIC T4 Gb	Ex e ib mb [ia Ga] IIC T4 Gb , Ex e ib mb [ia IIIC Da] IIC T4 Gb

The stars replace a combination of characters, depending on the product.

Electrical data see EC-type-examination certificate or datasheet.

1.6 Intended Use

The devices are isolated device couplers for fieldbus technology that connect field devices through intrinsically safe spurs to the trunk of a segment in accordance with IEC 61158-2.

Each spur individually limits or isolates the current during a spur failure, ensuring that the remaining segment is not affected.

FieldBarriers may be installed in hazardous areas of category 3G Zone 2 or of category 2G Zone 1. The intrinsically safe spur outputs could lead into hazardous areas of category 1G/D Zone 0/20. Types of protection are Ex ia for Zone 1, Gas Groups IIC, IIB, IIA. Field equipment connected to the spurs may be installed in in the following areas Zone 0, Gas Groups IIC, IIB, IIA.

The devices are designed for wall/panel mounting the housing or for DIN rail mounting on a 35 mm DIN rail according to EN 60175.

The spurs are intrinsically safe according to the FISCO or ENTITY concept.

The devices are only approved for appropriate and intended use. Ignoring these instructions will void any warranty and absolve the manufacturer from any liability.

The device must only be operated in the ambient temperature range and at the relative humidity (non-condensing) specified.

1.7 Improper Use

Protection of the operating personnel and the overall system is not ensured if the product is not being used according to its intended purpose.

1.8 Mounting and Installation

Prior to mounting, installation, and commissioning of the device you should make yourself familiar with the device and carefully read the instruction manual.

Do not install damaged or polluted devices.

The maximum allowed ambient temperature range is -40 °C ... +70 °C.



The devices may be installed in a corrosive location acc. to ISA-S71.04-1985, severity level G3.

In order to bridge the terminals, only use the supplied plug-in jumpers.

Hazardous Area

If devices have already been operated in general electrical systems, they may subsequently no longer be installed in electrical systems used in combination with hazardous areas.

The installation instructions in accordance with IEC/EN 60079-14 must be observed.

The installation instructions in accordance with IEC/EN 60079-25 must be observed.

Installation Notes on Cables and Wires

If cables or wires are needed for installation, the following points must be considered/evaluated:

Do not connect the signal wires to earth or to the cable shield.

The permissible cross section of conductors must be considered.

The insulation stripping length must be considered.

The tightening torque for the screws of the terminal must be considered.

If you use stranded wires, crimp on wire end ferrules.

Connectors for non-intrinsically safe circuits must be mechanically secured.

Connectors are only allowed to be manipulated at ambient temperatures between -5 °C and +70 °C.

Shielding in Non-/Intrinsically Safe Circuits

The shield of each intrinsically safe circuit is internally connected to the grounding terminal via a capacitor.

Spur cable shield grounding:	Capacitive via 4.4 nF
------------------------------	-----------------------

The shield of the non-intrinsically safe circuit is internally connected to the grounding terminal via a capacitor.

Trunk cable shield grounding:	Capacitive via 5.7 nF Direct
-------------------------------	---------------------------------

The capacitor can be bypassed by setting the plug-in jumper between specified terminals. Consider clause 12.2.2.3 of IEC/EN 60079-14.

Type of Protection Ex e

If intrinsically safe and non-intrinsically safe circuits are being operated together, the connections of the non-intrinsically safe circuits must be covered. The cover must comply with degree of protection IP30 according to IEC/EN 60529.

The non-intrinsically safe cables have to be fixed with cable ties at the intended fixtures.



1.8.1 Intrinsically Safe Circuits

Type of Protection Ex i

All separation distances between intrinsically safe and non-intrinsically safe circuits must be observed in accordance with IEC/EN 60079-14.

For intrinsically safe circuits, the dielectric strength of the insulation against other intrinsically safe circuits and against the shield must be at least 500 V according to IEC/EN 60079-14.

Prevent any electrostatic charge that could result in electrostatic discharge while installing or operating the device.

The IP30 connection cover of the device must be attached.

After de-energizing the device, a specified delay before opening the cover has to be maintained.

Minimum delay before opening the IP30 cover:	5 s
--	-----

The device provides a grounding terminal to which an equipotential bonding system with a minimum diameter of 4 mm² must be connected.

Connection or disconnection of energized non-intrinsically safe circuits is only permitted in the absence of a hazardous atmosphere.

Connection or disconnection of plug-in jumpers is only permitted in the absence of a hazardous atmosphere.

Instructions for Zone 1 and Zone 2

The device may be installed in gas groups IIC, IIB and IIA.

The devices must be installed and operated only in surrounding enclosures that

- comply with the requirements for surrounding enclosures according to IEC/EN 60079-0
- are rated with the degree of protection IP54 according to IEC/EN 60529

Instructions for Zone 21

The devices may only be installed and operated in a hazardous area requiring equipment protection level Db (Zone 21) if mounted in a surrounding enclosure for which an EC-type-examination certificate according to 94/9/EC for at least equipment protection level Db (category 2D) exists.

Instructions for Zone 22

The devices may only be installed and operated in Zone 22 if mounted in a surrounding enclosure for which an EC-type-examination certificate according to 94/9/EC for at least category 3D exists.

1.9 Repair and Maintenance

The devices must not be repaired, changed or manipulated. If there is a defect, the product must always be replaced with an original device.

1.10 Delivery, Transport and Storage

Check the packaging and contents for damage.

Check if you have received every item and if the items received are the ones you ordered.

Keep the original packaging. Always store and transport the device in the original packaging.

Always store the device in a clean and dry environment. The permitted storage temperature (see data sheet) must be considered.



1.11 Disposal

Disposing of devices, packaging material, and possibly contained batteries must be in compliance with the applicable laws and guidelines of the respective country.

2 Product Specifications

2.1 Overview and Application

R4D0-FB-IA* FieldBarriers are bus powered isolated fieldbus device couplers. The FieldBarrier connects up to 12 intrinsically safe field instruments to non-intrinsically safe segments, based on the High Power Trunk concept.

This product line is designed for FOUNDATION Fieldbus H1 and PROFIBUS PA systems in accordance with IEC 61158-2. This FieldBarrier is in accordance with the fieldbus device coupler test specification FF-846.

Indicating diagnostic information

An LED on the FieldBarrier indicates bus communication activity/physical layer diagnostic states and power on the trunk. Each spur is equipped with an LED for indication of a short circuit condition or fault at the spur.

Mounting and enclosure of R4D0-FB-IA* FieldBarriers

The FieldBarrier is designed for DIN rail mounting or wall mounting installation. It can be installed in a fieldbus junction box or a control cabinet. Pepperl+Fuchs offers various choices or tailored enclosure solutions.

Connection layout

1 field instrument is connected to 1 output or spur, and 1 or more FieldBarriers are connected to the segment or trunk. The spurs are galvanically isolated from the trunk. R4D0-FB-IA* offer the choice from 8...12 spur connections. Available connection options for trunk and spurs are:

- Pluggable connectors with screw terminals
- Pluggable connectors with spring terminals

Type of protection

The outputs of the FieldBarrier are classified intrinsically safe Ex ia IIC according to the FISCO and Entity model. Therefore the FieldBarrier is certified for installation in Zone 1. Live maintenance at the field device level in Zone 1 and Zone 0 is supported.

Tailored solutions

Pepperl+Fuchs offers various choices or tailored factory-assembled enclosure solutions. R4D0-FB-IA* FieldBarriers support trunk and spur surge protection and the possibility to perform live maintenance at the trunk connection.

R4D0-FB-IA*: Simplified architecture, increased stability, easy system integration

Due to its high-density configuration and simplified architecture, the FieldBarrier reduces the system 'foot print' and eliminates many points of failure. R4D0-FB-IA* reduce the number of interconnecting components that other solutions use. External components, such as the terminator and surge protectors are integrated within live-mating connectors that connect directly into the FieldBarrier. This way, transitional connections and components are reduced, the system integrity is increased, and the operational steps for installation and maintenance are simplified.

The integration of components with interconnecting terminals that are live-mating reduces overall size and increases the system availability. Less patch or link cables, or external electromechanical isolators are needed, and system integration and the overall level of maintenance take less time.

This offers many advantages over complex and high component count solutions with discrete plug-in modules. Each connection transition of these solutions presents a failure point and leads to maintenance problems. For example, the more connector sockets, the higher the risk of damaging a pin connector.

Monitoring and diagnostic options

R4D0-FB-IA* FieldBarriers offer device-level integrated Physical Layer Diagnostics as a standard. Important physical layer parameters, e. g. communication signal levels and signal jitter, are monitored and compared to trip values for each participating field instrument. The physical layer parameters used, are derived from the IEC 61158–2 physical layer specification or from empirical data.

A fault summary status alarm is shown on the FieldBarrier via an LED indicator. The alarm can be issued in detail, i.e., via specific field instrument diagnostics, using an Advanced Diagnostic Module (ADM). The ADM is positioned in the specific working environment of a control system.

Receptacles for the Mobile Advanced Diagnostic Module or similar

By default, receptacles for measuring tools such as the Mobile Advanced Diagnostic Module are included. This way, maintenance and commissioning personnel can conduct measurements in the field without wiring tools, and the wiring is never disturbed.

Failure condition handling (short circuit limitation and beyond)

The design of the R4D0-FB-IA* FieldBarriers focuses on fault tolerance towards failure conditions on the spur/field device level, threatening the entire segment to fail.

Each spur is equipped with short circuit current limitation with unique features:

- **Spur Contact Bounce Protection:** Protects the segment from continuous or intermittent current changes due to poorly attached, fractured, or loose fieldbus wires at a spur. When under vibration, wires can keep connecting and disconnecting to the attached field device load. The Pepperl+Fuchs Spur Contact Bounce Protection protects the fieldbus communication from permanent disturbances, and safeguards the segment against failure.
- **Progressive Spur Short Circuit Current Limitation:** Avoids segment failure in situations where the spur current progressively rises. For example, if water ingresses in the terminal arrangement, this leads to increasing conductivity between the fieldbus wires and causes the current limiting electronics to dampen the communication signals due to increasing impedance. The FieldBarrier safely isolates any affected spur in order to prevent a total segment failure.
- **Device Jabber Protection:** Specific software or hardware failures can cause the field instrument to communicate continuously (Jabber). The FieldBarrier has an integrated device jabber inhibitor that first detects faults caused by device jabber, and then immediately isolates the faulty device from the segment.

If a spur has a short circuit or failure, the fieldbus trunk and all other field devices remain in operation. When the fault is repaired, the FieldBarrier automatically resumes normal operation of the spur.

Surge protection for R4D0-FB-IA* FieldBarriers

Optional pluggable surge protection modules are available. The modules are designed to replace the individual connectors at the spurs. This way, surge protection components can be installed in existing cabinets without the need for more space.

Termination for R4D0-FB-IA* FieldBarriers

A fieldbus terminator with a high-availability design is optionally available in the FieldBarrier. The terminator can be activated via a bridge.



2.2 Component Identity

Component Dimensions

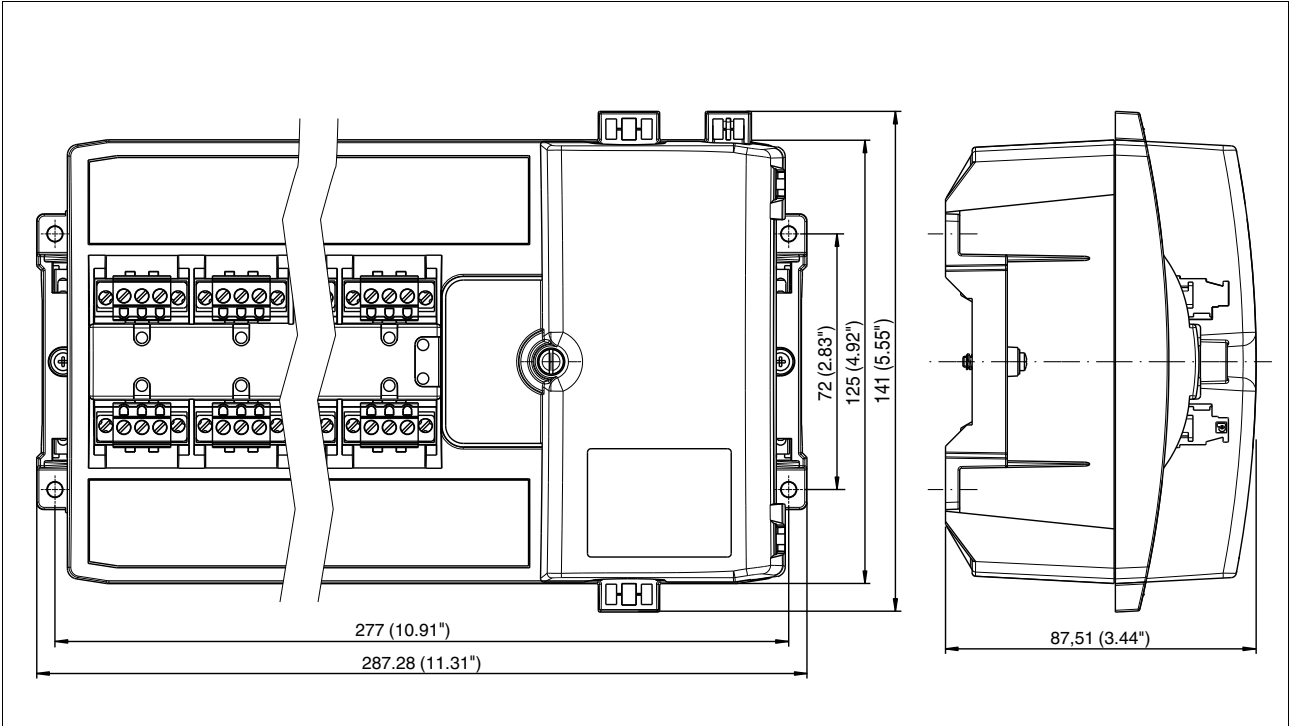

R4D0-FB-IA* housing dimensions including drilling plan

All dimensions in millimeters (mm) and inch (") without tolerance indication

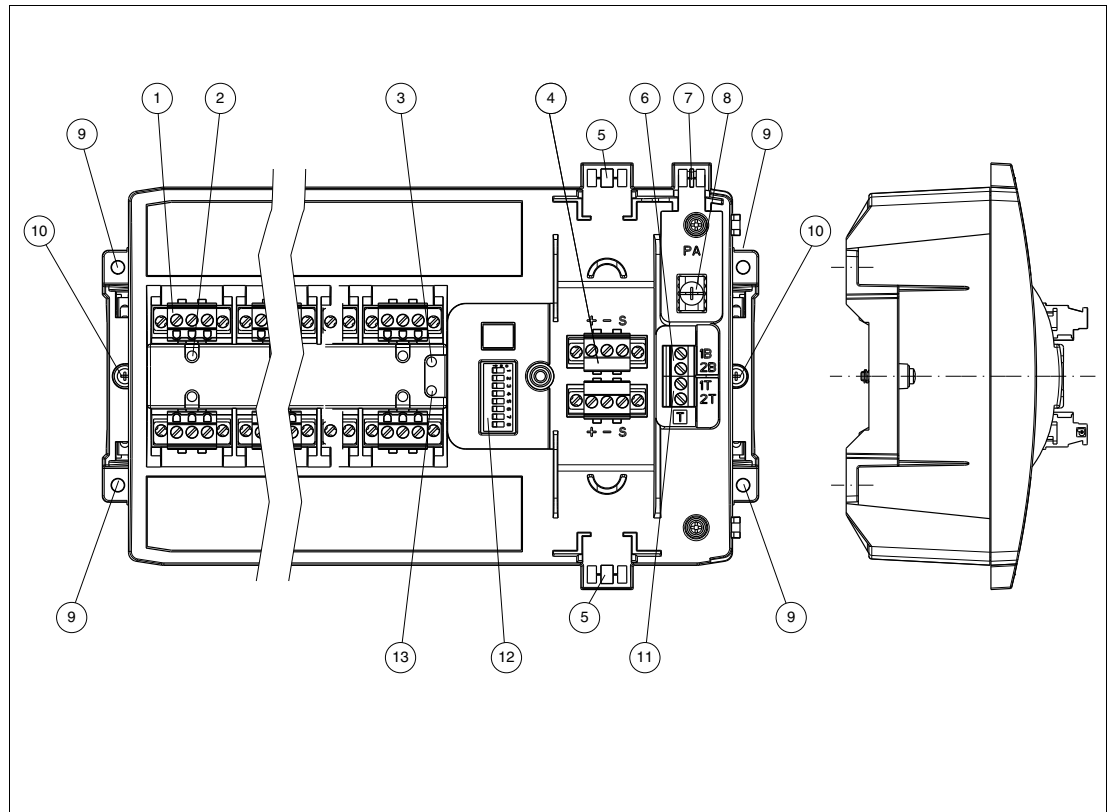



- 1 Spur connectors (* no. of spurs)
- 2 Spur LEDs (* no. of spurs)
- 3 PWR LED
- 4 Trunk connection
- 5 Cable ties fixture for trunk cable (* 2)
- 6 Terminal for cable shield grounding configuration
- 7 Cable ties fixture for grounding cable
- 8 Grounding terminal
- 9 Hole for wall mounting (* 4)
- 10 DIN rail mounting fixture (* 2)
- 11 Terminal for terminator configuration
- 12 DIP switches for diagnostic configuration (1-2 in use, 3-8 n/a)
- 13 LED COM/ERR (communication/diagnostics)

2.3 Technical Data R4D0-FB-IA*

Technical data	
Fieldbus interface	
Power loss	See table "Technical data depending on model" on page 16
Main cable (Trunk)	
Rated voltage	16 ... 32 V DC , min. 15 V in case of brown out
Rated current	trunk IN to trunk OUT max. 2 A see table 1 See table "Technical data depending on model" on page 16

Technical data	
Cable screen grounding option	Capacitive via 5.7 nF Direct
Voltage drop	trunk IN to trunk OUT 100 mV max.
Number of couplers	max. 3 per segment
Reverse polarity protection	Built-In
Outputs	
Number of outputs	8, 10 or 12
Number of devices per output	1
Cable length	120 m
Rated voltage	10 ... 14 V
Rated current	max. 43 mA at one spur , max. 320 mA total current at all spurs
Short-circuit current	53 mA , 1 mA in fallback state
Cable screen grounding option	Capacitive via 4.4 nF
Surge protection	Trunk overvoltage protection if voltage exceeds typ. 39 V, max. 41 V
Diagnostic and Protection Features	
Fault Isolation	Short Circuit Current Limitation at spurs Bounce Protection at spurs Signal inhibit at spurs
Physical Layer Diagnostic	Signal level at spurs Signal jitter at spurs Noise level at spurs
Indicators/operating means	
Switch	S1 ON: diagnostic alarms activated S2 ON: diagnostic warnings activated S3-S8: not used
LED PWR	green: Fieldbus voltage > 16 V
LED COM/ERR	yellow flashing: fieldbus communication and physical layer status , red: Hardware error
LED SPURS	red: 2 Hz flashing in short-circuit condition
Electrical isolation	
Main wire/outputs	isolation is not affected by interference according to EN 60079-11, voltage peak value 375 V
Output/Output	No Isolation
Directive conformity	
Electromagnetic compatibility	
Directive 2004/108/EC	EN 61326-1:2013
Standard conformity	
Electromagnetic compatibility	NE 21:2011
Protection degree	IEC/EN 60529
Fieldbus standard	IEC 61158-2
Climatic conditions	IEC 60721
Shock resistance	EN 60068-2-27

Technical data	
Vibration resistance	EN 60068-2-6
Ambient conditions	
Ambient temperature	-40 ... 70 °C (-40 ... 158 °F)
Storage temperature	-40 ... 85 °C (-40 ... 185 °F)
Relative humidity	< 95 % non-condensing
Shock resistance	15 g 11 ms
Vibration resistance	1 g , 10 ... 150 Hz
Corrosion resistance	acc. to ISA-S71.04-1985, severity level G3
Mechanical specifications	
Connection type	pluggable , screw terminal or spring terminal
Core cross-section	See chapter 3.4.2, See chapter 3.4.1
Housing material	Polycarbonate
Protection degree	IP20 , IP30 for Ex-e terminal cover
Dimensions	→ see image on page 12
Mounting	DIN rail mounting and panel mounting
Data for application in connection with Ex-areas	
EC-Type Examination Certificate	BVS 13 ATEX E 121 X
Group, category, type of protection, temperature class	 II 2 (1)G Ex e ib mb [ia Ga] IIC T4 Gb ,  II 2 G (1D) Ex e ib mb [ia IIIC Da] IIC T4 Gb
Main cable (Trunk)	
Maximum safe voltage U_m	253 V AC
Outputs	in accordance to FISCO and Entity
Voltage	17.1 V
Current	248.55 mA
Power	1.063 W
Inductance	gas group IIC 470 μ H , gas group IIB 2 mH
Capacitance	gas group IIC 367 nF , gas group IIB 2.15 μ F
Directive conformity	
Directive 94/9/EC	EN 60079-0:2012 , EN 60079-7:2007 , EN 60079-11:2012 , EN 60079-18:2009
International approvals	
CSA approval	pending
IECEx approval	IECEx BVS 13.0119X
Approved for	Ex e ib mb [ia Ga] IIC T4 Gb , Ex e ib mb [ia IIIC Da] IIC T4 Gb
Certificates and approvals	
FOUNDATION Fieldbus	FF-846
Marine approval	pending

Technical data	
General information	
Supplementary information	EC-Type Examination Certificate, Statement of Conformity, Declaration of Conformity, Attestation of Conformity and instructions have to be observed where applicable. For information see www.pepperl-fuchs.com .

Technical data depending on model

Input voltage, current and power loss (power dissipated)		Zero load	1 x 20 m A load	20 mA loads all spurs	20 mA loads all spurs and 1 spur short circuit	Full capacity load (320 mA total)
12 Spur						
16 V	Trunk current	55 mA	75 mA	316 mA	356 mA	414 mA
	Power loss	-	0.85 W	2.4 W	2.7 W	3.1 W
32 V	Trunk current	43 mA	54 mA	172 mA	188 mA	213 mA
	Power loss	-	1.8 W	2.7 W	3 W	3.3 W
10 Spur						
16 V	Trunk current	55 mA	75 mA	270 mA	308 mA	414 mA
	Power loss	-	0.85 W	2 W	2.4 W	3.1 W
32 V	Trunk current	43 mA	54 mA	150 mA	168 mA	213 mA
	Power loss	-	1.8 W	2.4 W	2.7 W	3.3 W
8 Spur						
16 V	Trunk current	55 mA	75 mA	225 mA	262 mA	414 mA
	Power loss	-	0.85 W	1.7 W	2 W	3.1 W
32 V	Trunk current	43 mA	54 mA	127 mA	146 mA	213 mA
	Power loss	-	1.8 W	2 W	2.3 W	3.3 W

Table 2.1 Technical data depending on model

3 Installation and Commissioning

In the following section you find information on how to install and commission the device in your fieldbus topology.



Note!

Before performing any work: Read the section on Safety, see chapter 1, especially all sections that are relevant for your application.

3.1 Mounting and Dismounting

The FieldBarrier can be mounted in 2 different ways:

1. Wall/panel mounting
2. DIN rail mounting on a 35 mm DIN mounting rail according to EN 60715



To mount the FieldBarrier on a wall/panel

1. Determine the position of the FieldBarrier on the wall/panel.
2. Prepare the wall/panel with precisely positioned drill holes and wall plugs:
Wall plug type: Depends on the material of the wall/panel.
3. Place the FieldBarrier on the wall/panel and fix it with the appropriate screws. Use the 4 holes designated for wall/panel mounting.
Screw size/type: M4
Screw type: Depends on the wall plug type used.
Torque: 1.5 Nm

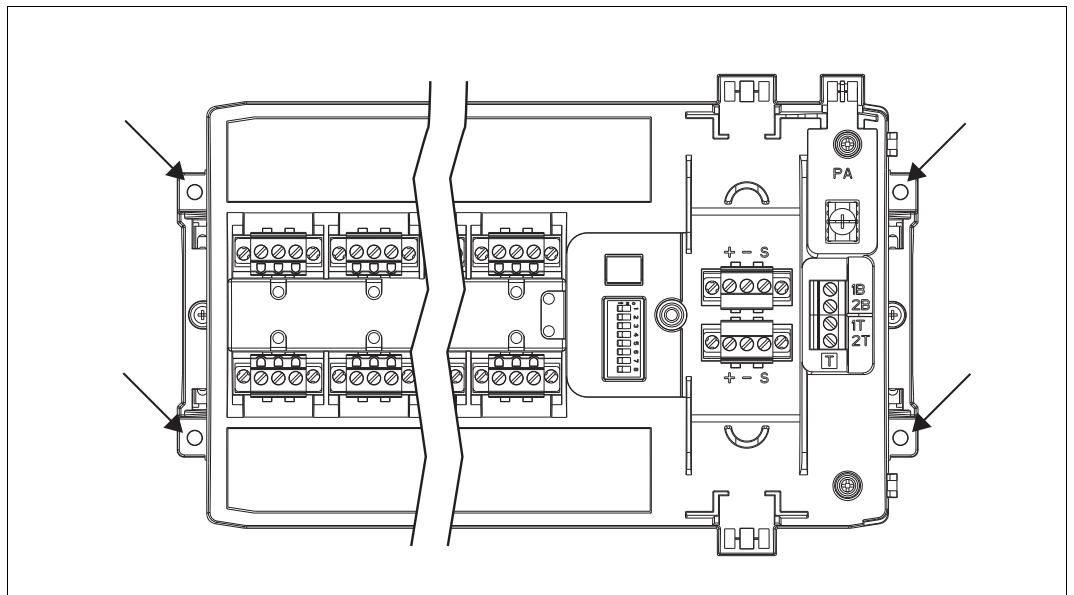



To mount the FieldBarrier on a DIN rail

1. Place the FieldBarrier on the DIN rail.

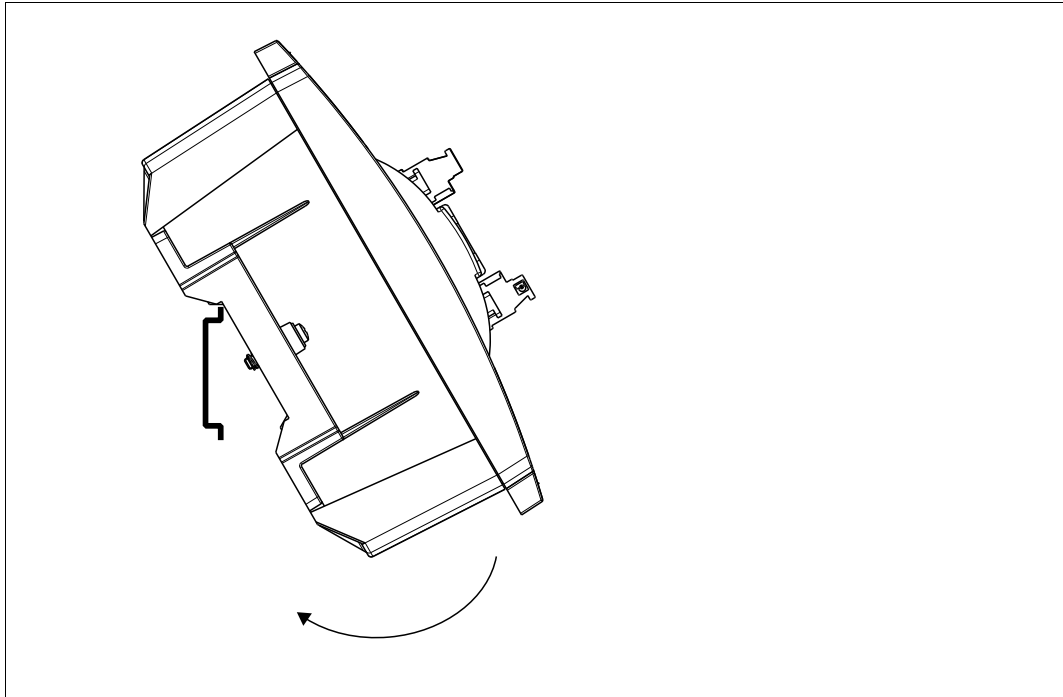

2. To fix the FieldBarrier onto the DIN rail: Use DIN rail clamp screws and the intended DIN rail fixtures.

Torque for screwing the FieldBarrier securely to the DIN rail: 1 Nm

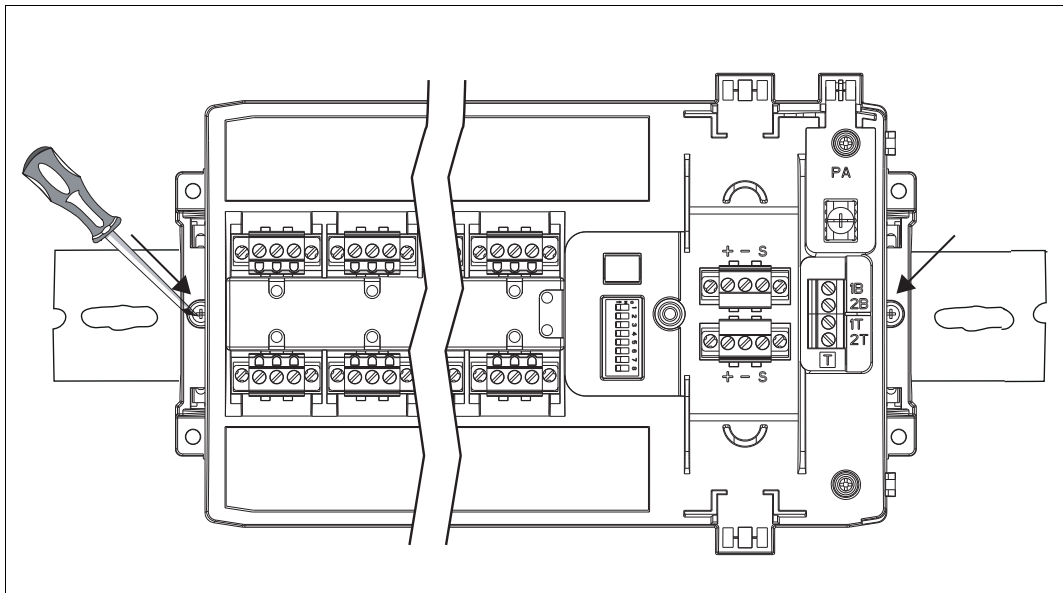



To dismantle the FieldBarrier (DIN rail)

1. DIN rail mounting: Undo the DIN rail clamp screws at the fixtures of the device coupler that keep it to the DIN rail:

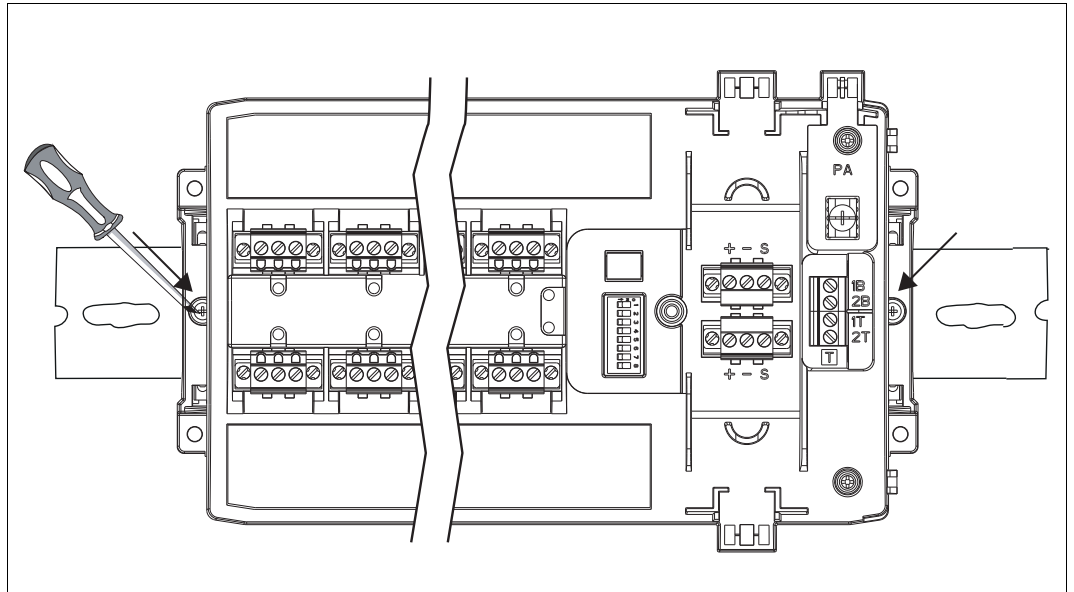

2. Take the device coupler off the DIN rail.

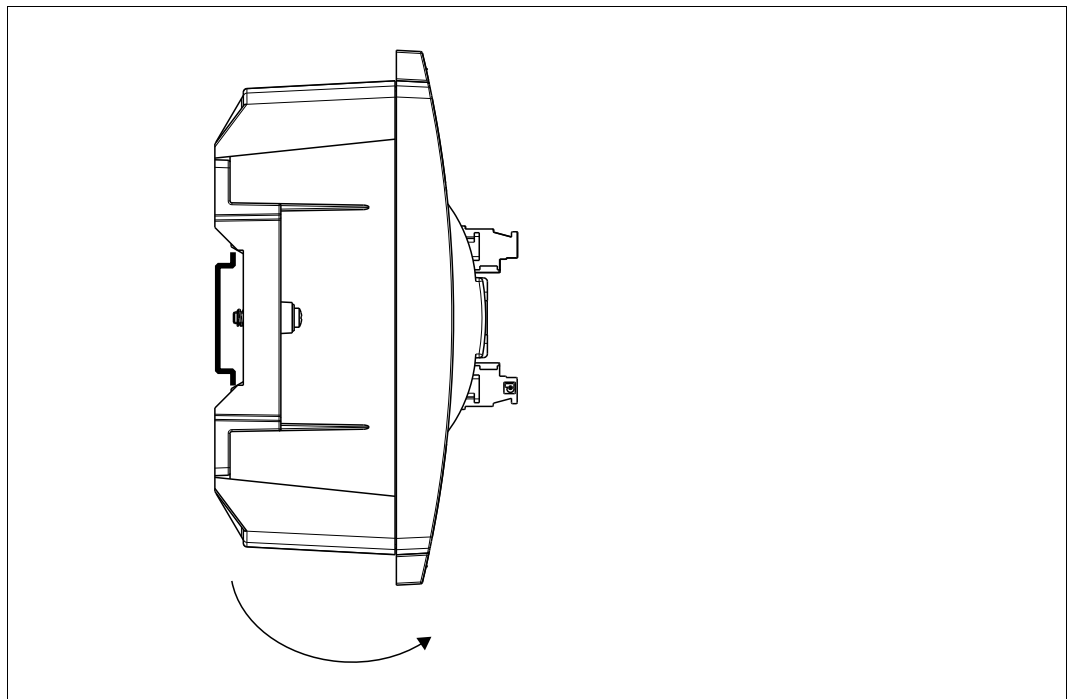



To dismount the FieldBarrier (wall/panel)

1. Wall/panel mounting: Undo the screws that keep the FieldBarrier attached to the wall:

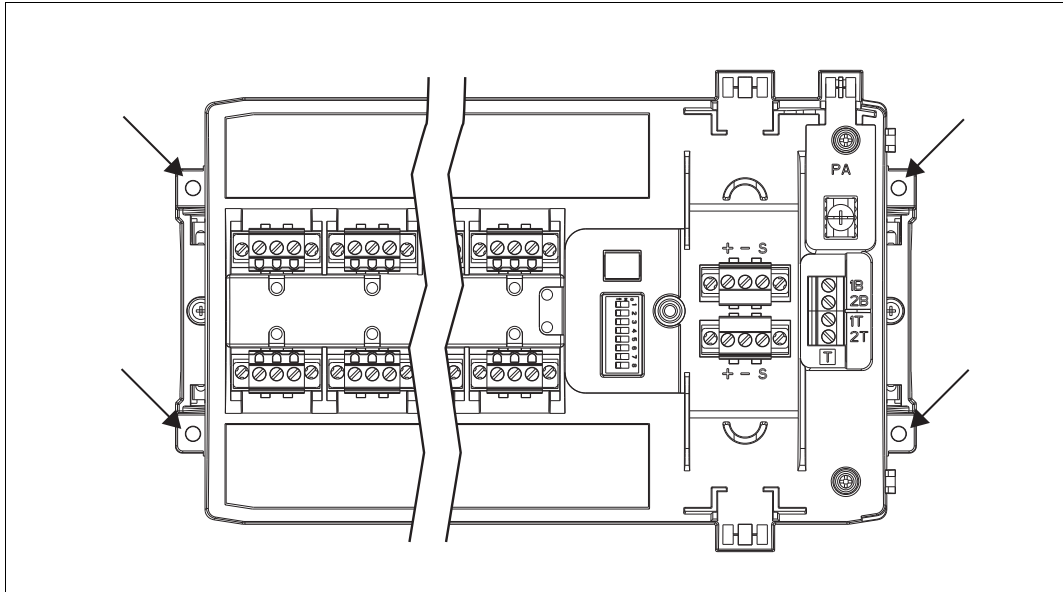

2. Take the device coupler off the wall/panel.

3.2 FieldBarrier Attaching/Detaching the IP30 Trunk Connection Cover



Danger!

Risk of explosion through unprotected non-intrinsically safe circuits in hazardous areas

In hazardous areas, opening the cover while the device is energized or failing to attach the trunk connection cover to the FieldBarrier housing can cause the following results:
Sparks caused by the life non-intrinsically safe circuits may ignite the surrounding hazardous atmosphere, causing an explosion. This may result in personal death or injury. Also, this may result in severe property damage.

Never open the IP30 cover when the device is energized.
In order to protect all non-intrinsically safe circuits, ensure that the IP30 cover is properly attached to the FieldBarrier housing as shown below.



Danger!

Risk of explosion through sparking by residual current

After de-energizing the FieldBarrier, non-intrinsically safe circuits can still carry residual current that can ignite the surrounding hazardous atmosphere.

After de-energizing the device:
Wait at least 5 seconds, before you open the IP30 trunk cover.

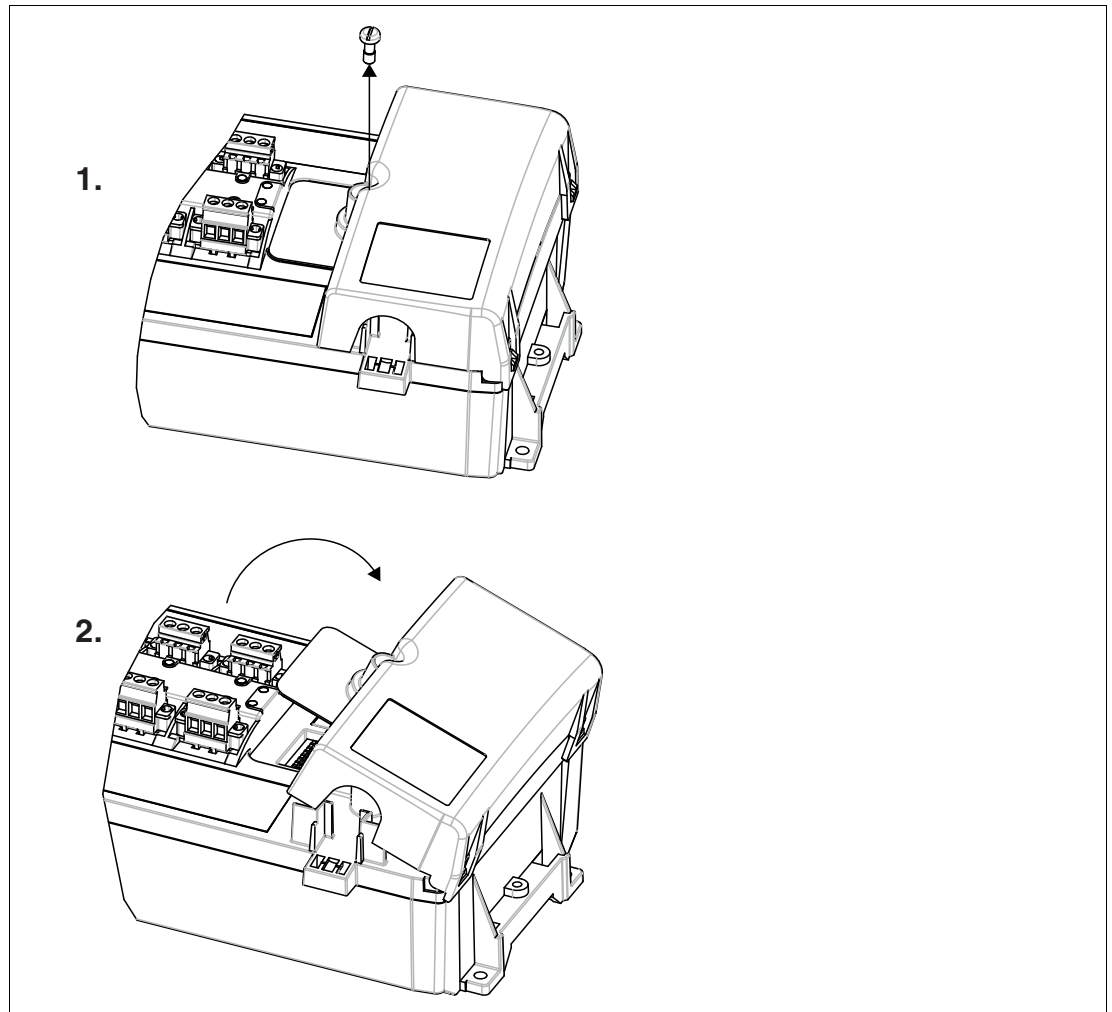

Note!

If the FieldBarrier is installed in hazardous areas Zones 1, 2, 21, or 22 protect all non-intrinsically safe circuits with an IP30 cover.

Ensure that the cover is properly attached by the holding screw.

You may remove the cover only in absence of an hazardous atmosphere.

3.3

DIP-Switch Physical Layer Diagnostics Configuration

An eight position DIP switch allows the configuration of the Physical Layer Diagnostic features:

R4D0-FB-IA* Dip switch settings

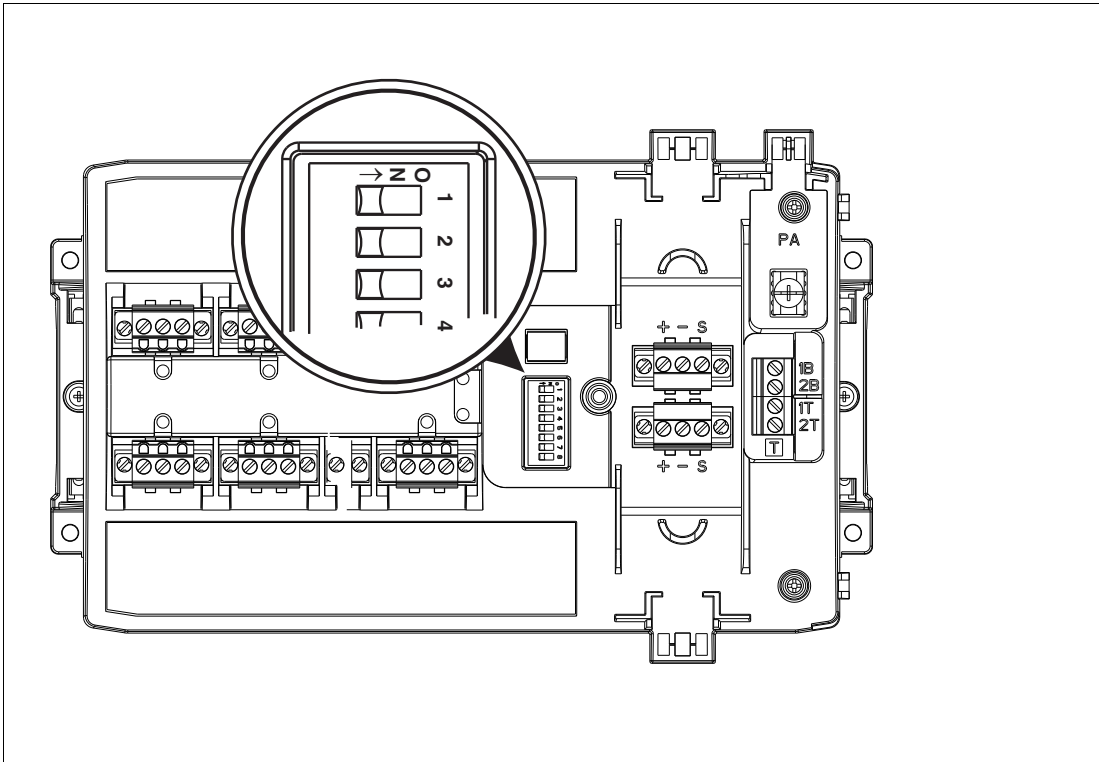

- Switch 1 position ON: Warnings for signal level, noise and jitter enabled
- Switch 1 position OFF: Warnings for signal level, noise and jitter disabled
- Switch 2 position ON: Alarms for signal level, noise and jitter enabled
- Switch 2 position OFF: Alarms for signal level, noise and jitter disabled
- Switch 3-8: not used

In default configuration, the switches 1 and 2 are switched ON.

3.4 Terminal Connections

For the trunk and spur connections, 2 types of terminals are available:

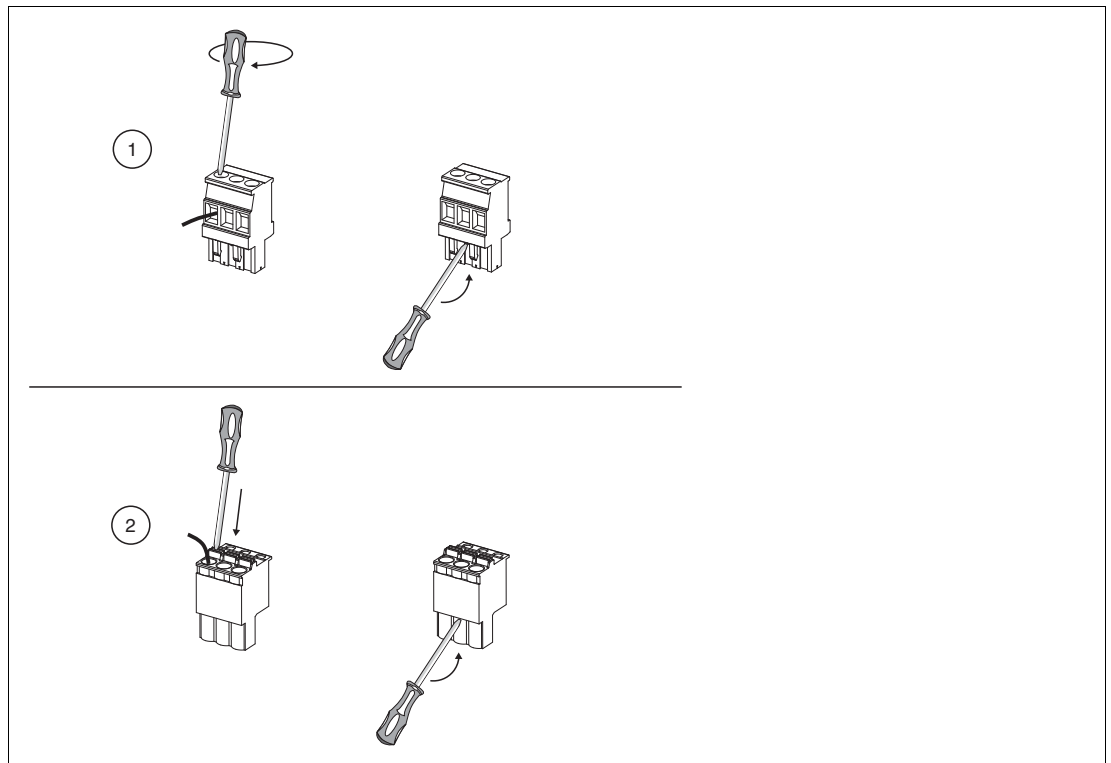

	Terminal connection type	Wiring	Removal
1.	Screw terminal	<ul style="list-style-type: none"> ■ Fasten/unfasten clamp screw ■ Enter/remove wire 	<ul style="list-style-type: none"> ■ Lever out with suitable tool
2.	Spring terminal	<ul style="list-style-type: none"> ■ Push in clamp with suitable tool ■ Enter/remove wire 	<ul style="list-style-type: none"> ■ Lever out with suitable tool

3.4.1 FieldBarrier Trunk Connection

Depending on the chosen pre-engineering options, the FieldBarrier can be connected with the fieldbus trunk in either of the following 2 ways:

1. Screw Terminals

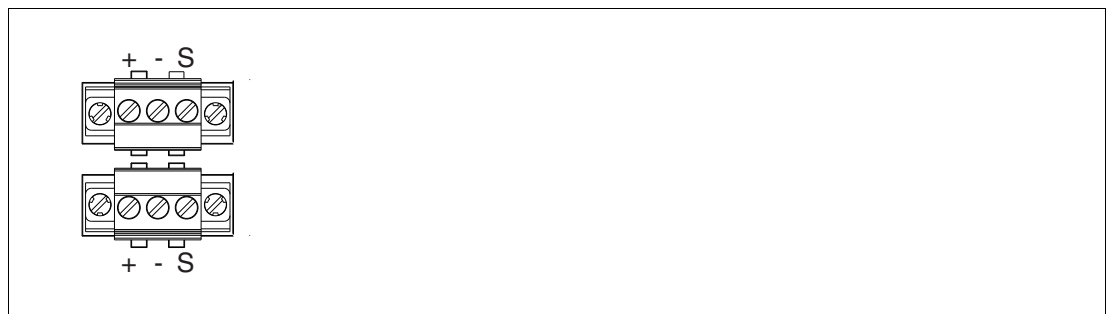

- + Segment +
- Segment -
- S Shield connection

2. Spring Terminals

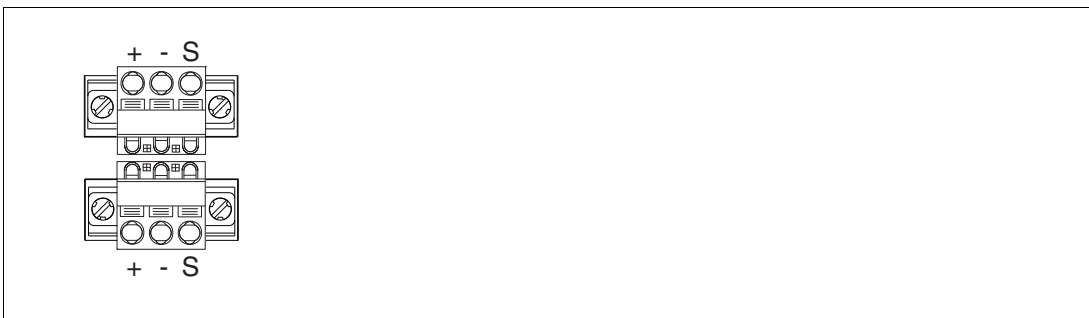

- + Segment +
- Segment -
- S Shield connection

Cable Position Fixture

The R4D0-FB-IA* housing provides special fixtures for cable ties.

To keep the cabling in a safe position, use the fixtures with cable ties.

Cable tie width: up to 4 mm



Note!

Protect Connectors Against Loosening

To protect the terminal connections against loosening: Always attach connectors with screws as designated.

Screw Terminals: Cable and Connection Information

- Permissible wire core section:
 - Screw terminals with flexible or rigid wires: 0.2-2.5 mm²
- Insulation stripping length: 7 mm
- If you use stranded wires: crimp on wire end ferrules
- Ensure that connectors are mechanically locked
- Torque required for tightening terminal screws: 0.4-0.5 Nm

Spring Terminals: Cable and Connection Information

- Permissible wire core section:
 - Spring terminals with flexible or rigid wires: 0.5-2.5 mm²
- Insulation stripping length: 10 mm
- If you use stranded wires: crimp on wire end ferrules
- Ensure that connectors are mechanically locked
- Torque required for tightening terminal screws: 0.4-0.5 Nm

3.4.2 FieldBarrier Spur Connections

Depending on the chosen pre-engineering options, the spurs can be connected to the FieldBarrier in either of the following 2 ways:

1. Screw Terminals

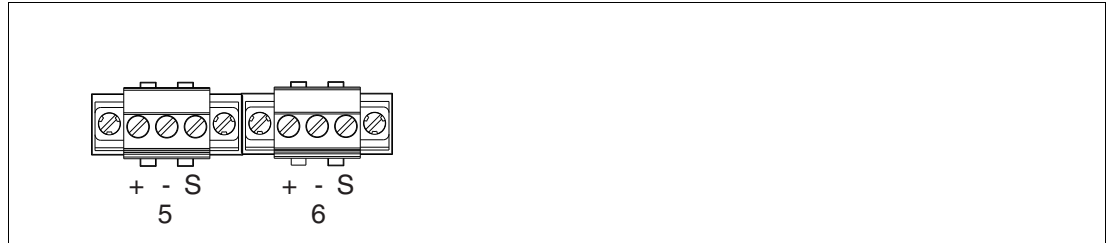

5 + 6 Spur connector

- +** Spur +
- Spur -
- S** Shield connection

2. Spring Terminals

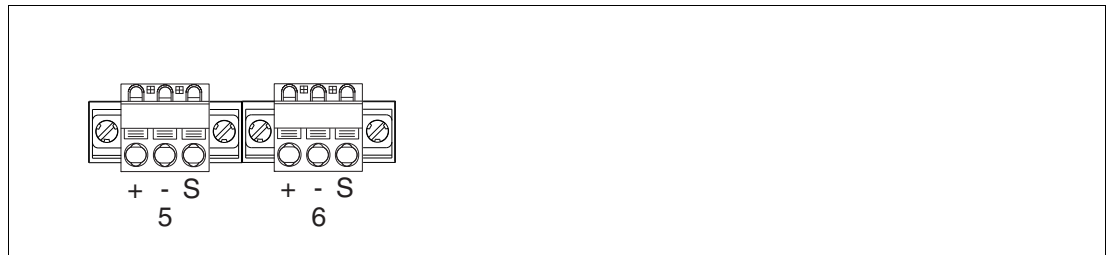

5 + 6 Spur connector

- +** Spur +
- Spur -
- S** Shield connection



Note!

Protect Connectors Against Loosening

To protect the terminal connections against loosening: Always attach connectors with screws as designated.

Screw Terminals: Cable and Connection Information

- Permissible wire core section:
 - Screw terminals with flexible or rigid wires: 0.2-2.5 mm²
- Insulation stripping length: 7 mm
- If you use stranded wires: crimp on wire end ferrules
- Ensure that connectors are mechanically locked
- Torque required for tightening terminal screws: 0.4-0.5 Nm

Spring Terminals: Cable and Connection Information

- Permissible wire core section:
 - Spring terminals with flexible or rigid wires: 0.5-2.5 mm²
- Insulation stripping length: 10 mm
- If you use stranded wires: crimp on wire end ferrules
- Ensure that connectors are mechanically locked
- Torque required for tightening terminal screws: 0.4-0.5 Nm

3.5 Grounding/Shielding

The following chapters describe how the spurs and the trunk of the FieldBarrier are grounded.

3.5.1 Grounding/Shielding the Spurs



Note!

Spur cable shield grounding: Capacitive via 4.4 nF
Each spur cable shield is capacitively coupled with the grounding terminal (PA).

The shields of the connected field devices can be either floating or connected to local earth.



Tip

For best immunity against EMC, we recommend to connect the shield to local earth.

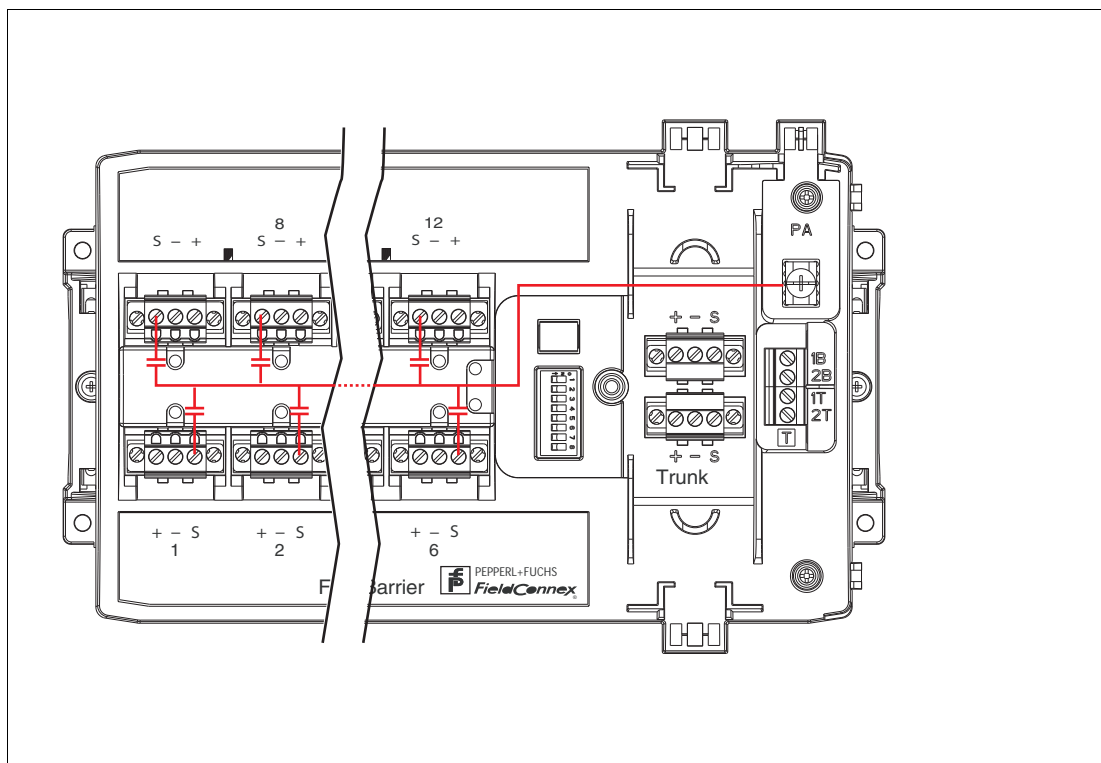

Figure 3.1 Stylized composition of the shield lines within the FieldBarrier



Warning!

Dangerous atmospheres and plant damages due to communication loss

Connecting signal leads of the spur lines to the earth potential or the cable shield during plant operation can cause communication loss with the segment. Serious plant damages or dangerous atmospheres can be the result.

Do not connect any signal leads of spur lines to earth potential or cable shield. After maintenance activities, always ensure that all the wirings have been reattached properly.

3.5.2 Grounding/Shielding the Trunk Cable



Note!

Trunk cable shield grounding: Capacitive via 5.7 nF, or direct

The trunk shield can be either connected directly or capacitively via a capacitor to earth.

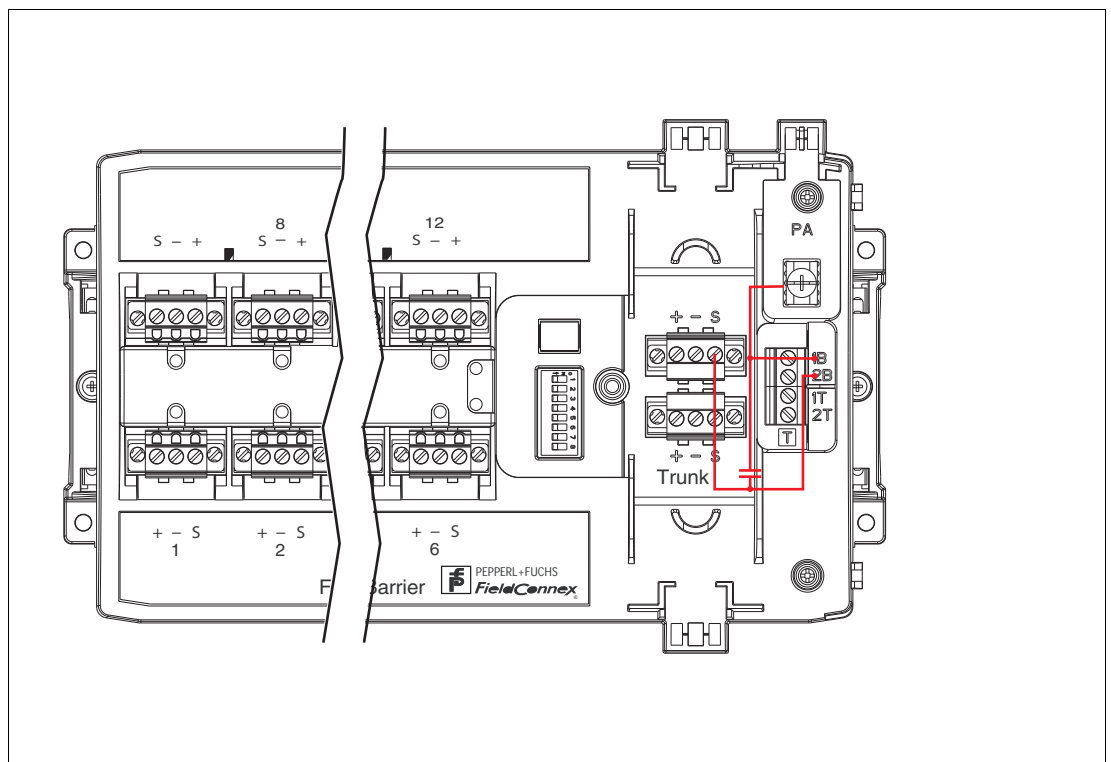

Figure 3.2 Stylized composition of the capacitive grounding of the trunk inside the FieldBarrier

General Information on Trunk Cable Shield Grounding

For trunk cable shield grounding, 2 wiring methods are widely used:

1. **Single-point grounding.** The trunk cable shield is connected directly at the power supply end of the fieldbus to a local earth, usually in the control room. Out in the field, at the end of device coupler housing, the shield is left disconnected and protected (floating). Or it is capacitively coupled to a local earth. Both methods prevent 'earth loops' from occurring.
2. **Double-point grounding.** The trunk cable shields are connected to earth at both ends. In this case, an equal potential line or equipotential bond between the 2 grounding points are necessary, in order to prevent earth loops. This grounding method provides the best protection against EMC effects.



To determine the grounding method

To choose between direct or capacitive grounding of the trunk, a grounding jumper is plugged in the respective position of the grounding screw terminal "B" and fixed with terminal screws at a torque of 0.4-0.5 Nm. The grounding jumper is included in the delivery.

1. **For capacitive grounding of the trunk:** Plug the grounding jumper into the parking position "-- 1B" of the screw grounding terminal.

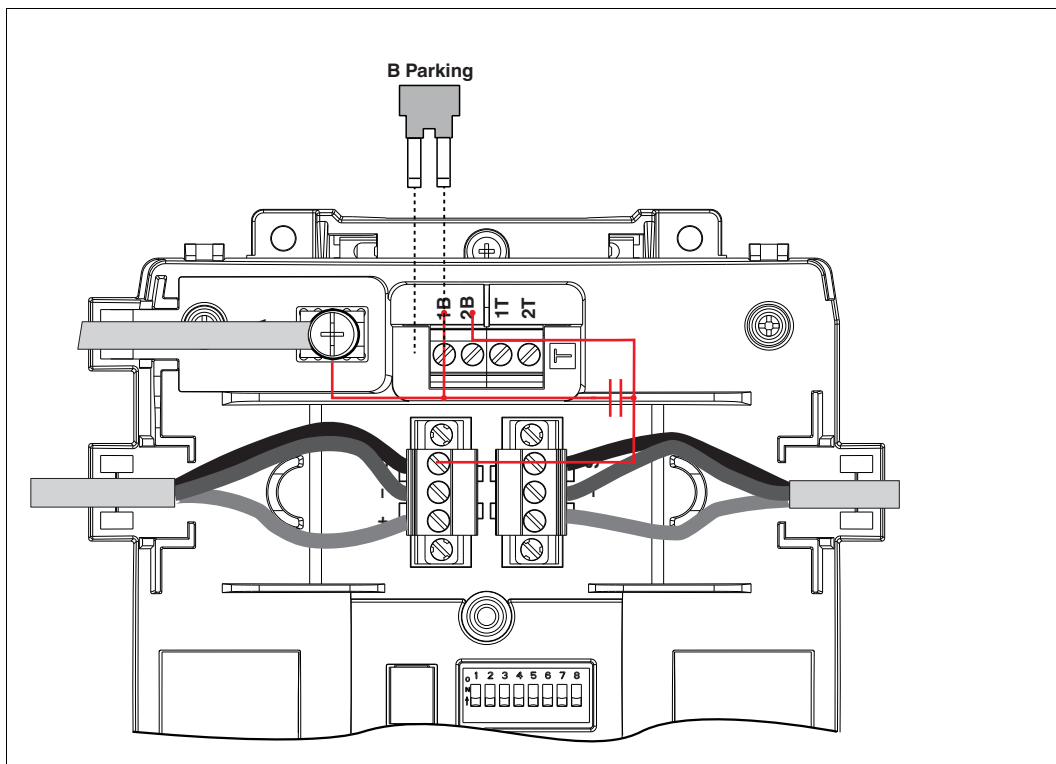

2. **For direct grounding of the trunk:** Plug the grounding jumper into the position "1B-2B" of the screw grounding terminal:

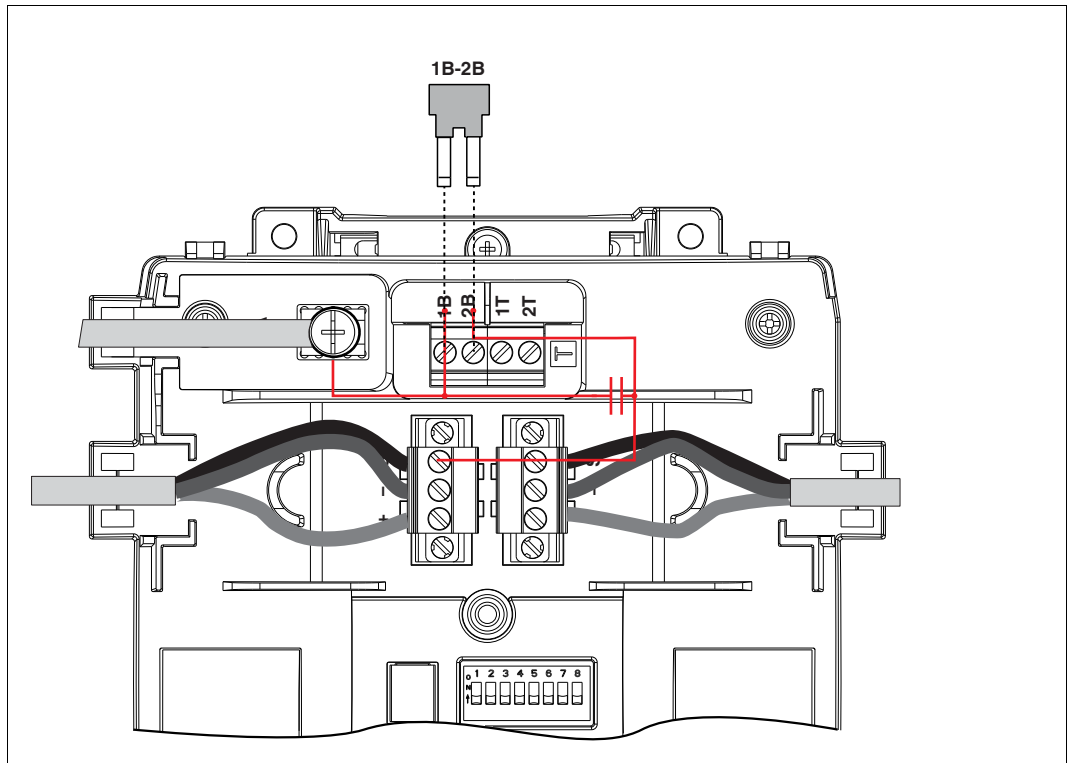

3. To fix the grounding jumper, tighten the terminal screws.
Torque required for tightening terminal screws: 04.-0.5 Nm

3.5.3 Grounding the FieldBarrier



Danger!

Danger to life through explosion or electric shock

Failing to connect all metal parts of the device to protective local earth can cause potential equalization currents. These can pose a danger to life for operating personnel through explosion or electric shocks.

In hazardous areas, grounding is mandatory. Connect all metal parts of the device to local earth to prevent any danger to personnel.

Using the Grounding Terminal

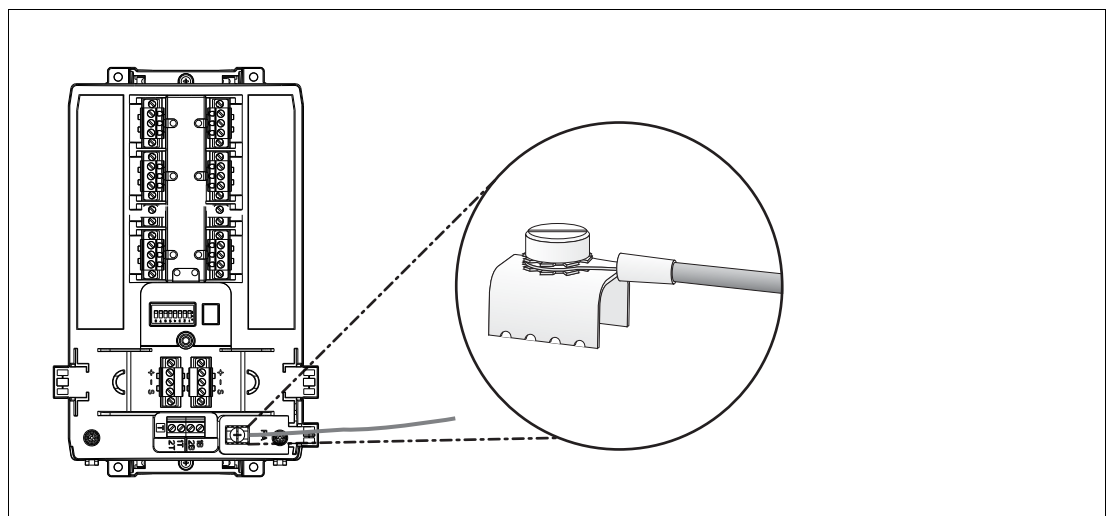

Figure 3.3 R4D0-FB-IA*: Grounding terminal position



Caution!

Risk of electric shock and property damage through inadequate grounding

If you fail to connect all metal parts of the device to protective local earth correctly, this could result in potential equalization currents. These currents could hurt operating personnel or cause property damage.

The grounding terminal is not a safety earth: Do not use the grounding terminal to ground exposed metal parts.
Ground exposed metal parts of the device separately. Ensure that a correct grounding is guaranteed at all times.



To connect the ground connection cable



Note!

Use a cable with a minimum cross core section of 4 mm².

1. Connect the ground cable to a cable lug.
2. Position the cable lug over the ground connection clamp with the cable pointing downwards.
3. Screw the cable lug to the ground connection clamp with 2 toothed lock washers inserted between screw, lug, and clamp as illustrated:

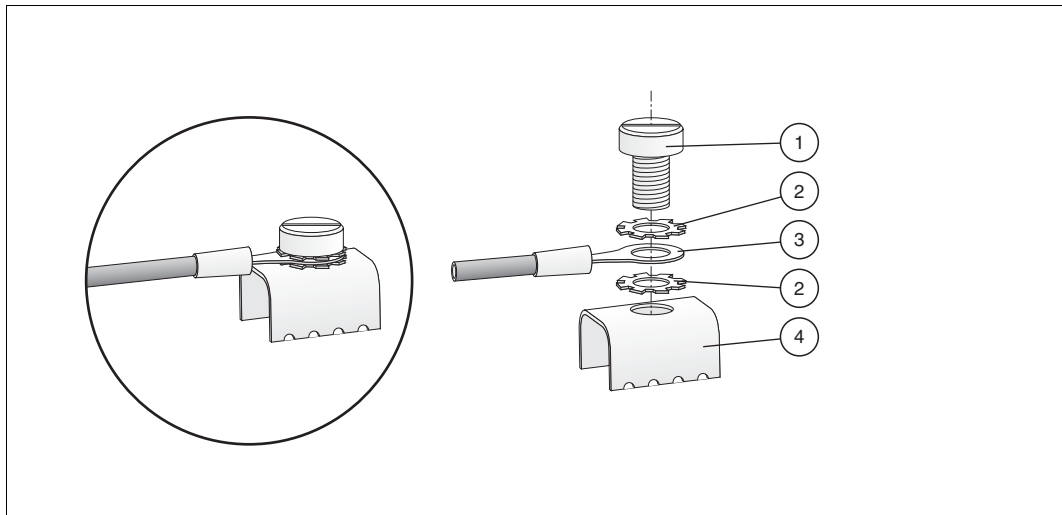

Figure 3.4 Connecting the ground connection cable

- 1 Screw
- 2 Toothed lock washer
- 3 Cable lug
- 4 Ground connection clamp on motherboard

4. Tighten the screw with a torque of 1.5 Nm.

↳ The cable lug is properly attached and cannot come loose.

Cable Position Fixture

The R4D0-FB-IA* housing provides special fixtures for cable ties.

To keep the cabling in a safe position, use the fixtures with cable ties.

Cable tie width: up to 4 mm

3.6

Trunk Termination

In order to connect several FieldBarriers in series, loop the trunk line through the PCB connectors.

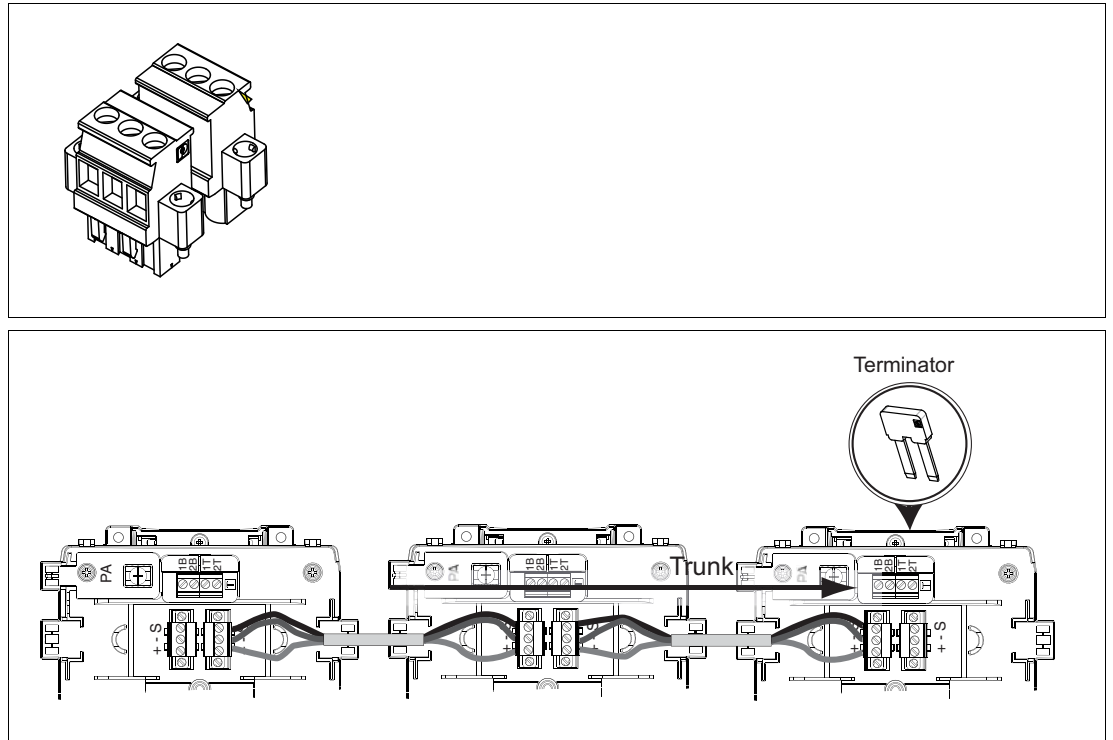

Figure 3.5 Stylized series connection and termination

To provide segment termination: Plug in the jumper (included in delivery) into the last termination terminal clamp of the segment.



To activate/deactivate trunk termination

To activate or deactivate trunk termination, a termination jumper is plugged in the respective position of the screw terminal "T" and fixed with terminal screws at a torque of 0.4-0.5 Nm. The termination jumper is included in the delivery.



1. Plug the termination jumper into the position "T1-T2":

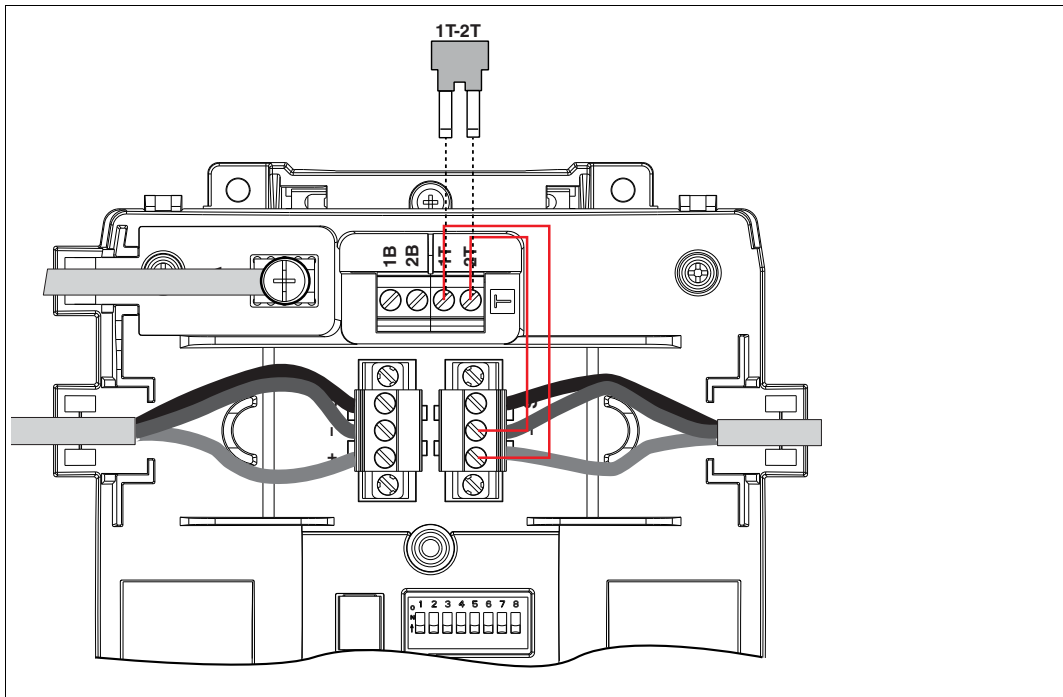

2. To deactivate the termination: Put the termination jumper into the parking position:

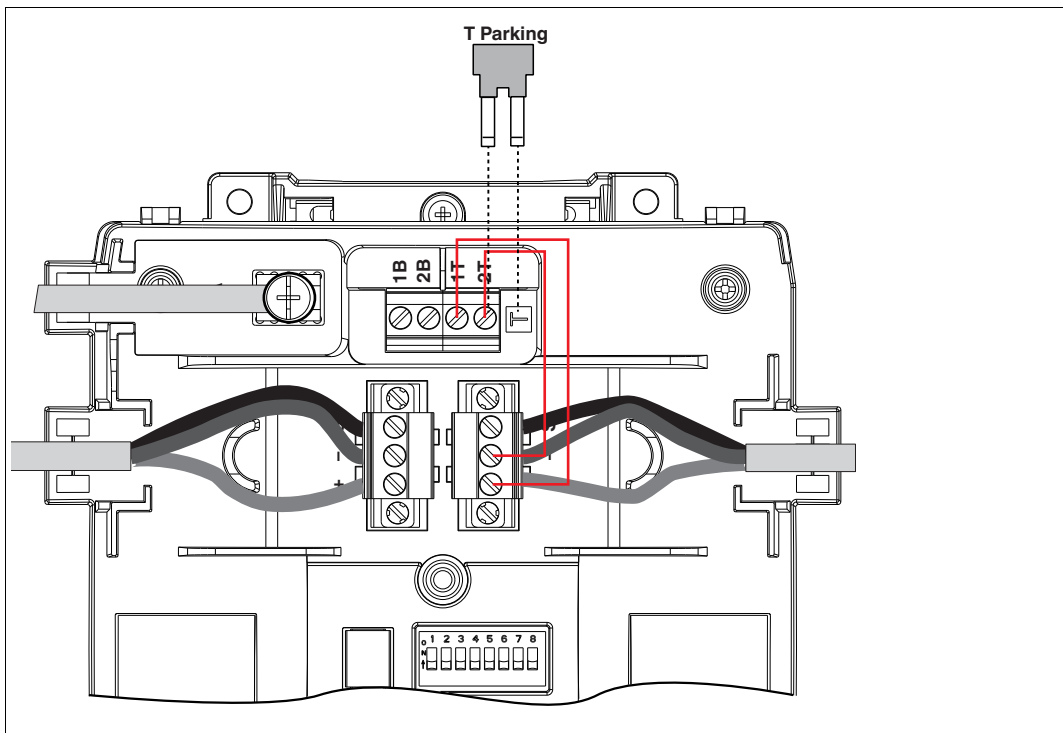

3. To fix the termination jumper, tighten the terminal screws.
Torque required for tightening terminal screws: 04.-0.5 Nm



Note!

Wrong termination causes communication problems. Make sure that the trunk is terminated with a terminator at each end of the trunk line (i.e., 2 terminators in total).

4 Operation

4.1 Indicators

The FieldBarriers include the following LEDs:

- One green "PWR" LED as indicator for power on the trunk
- One yellow/red "COMM/ERR" LED as indicator for bus communication activity and the physical layer diagnostic status
- Up to 12 red LEDs for up to 12 spurs as short circuit condition or fault indicator for each output (spur)

Trunk power LED PWR:







If the fieldbus trunk voltage exceeds 16 V, the LED is ON.

Spur fault LED:

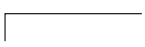
If the spur is switched OFF due to short circuit, bounce or jabber detection, the red spur fault LED is flashing.

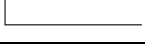
Diagnostic State LED COM:

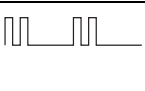
Depending on the diagnostic state, the diagnostic LED is either ON or flashing. For further information, see chapter 4.4.

Diagnostic State	Diagnostic LED Enunciation	LED Sequence	Diagnostic State/Cause
Hardware failure	LED red: ON		Hardware failure in electronic detected
Sum of spur current exceeded	LED red: flashing 3 close pulses per second		The total spur sum current of 320 mA is exceeded
No communication	LED yellow: OFF		No communication
Communication active	LED yellow: ON		Communication on trunk detected
Maintenance required	LED yellow: flashing 1 pulse per second		Maintenance required: ■ One or more physical layer values exceed the maintenance limits
Out of Specification	LED yellow: flashing 2 close pulses per second		Out of Specification: ■ One or more physical layer values exceed the out of specification limits ■ Hardware degradation or deviation from normal operation detected
Auxiliary alarms: ■ ELS-1 water sensor alarm ■ *LBF-IA1*, Surge Protector alarm	LED yellow: flashing 3 close pulses per second		Auxiliary alarms: ■ ELS-1 water sensor alarm detected ■ *LBF-IA1*, Surge Protector alarm detected

4.2 Current Management of the Spurs

The FieldBarrier incorporates a unique current management system that minimizes the impact of excessive current demands at the spur outputs and on the trunk.

Sequential Start-Up of Spurs

During power-up, the spurs are sequentially activated to minimize the initial high inrush current demand from the fieldbus power supply. Therefore, the fieldbus power supply is less stressed during the start-up phase, and its expected lifetime is increased.

Fold-Back Characteristics of the Spur Short Circuit Limiter

If a spur short circuit occurs, the spur current is switched off quickly and only returned when the short circuit has been cleared. If multiple simultaneous short circuits occur, the current management system minimizes the additional current demand of the fieldbus power supply. This prevents the risk of a segment shutdown due to a power supply overload trip or excessive trunk cable voltage drop.

Summated Spur Current Management

The FieldBarrier provides a maximum summated current of 320 mA to the spur outputs. If the maximum current is exceeded by overloading some or all spurs, the FieldBarrier switches off each spur in sequence from the highest spur number down to the lowest until 320 mA are reached.

This function ensures continued operation where an exchange of one or more field devices with higher currents would cause the segment to fail through power supply overcurrent, higher trunk, or spur voltage losses, or a FieldBarrier overcurrent.

4.3 Spur Noise

Noise is measured on the spur level in the frequency range of 1 kHz ... 300 kHz. Excessive noise disturbs the communication, leading to sporadic device dropout, and in the worst case causing the loss of a segment. Possible root causes are:

- EMC interferences
- EMC interferences in combination with signal unbalance to earth

Noise level "Maintenance required": $150 \text{ mV} > U_{\text{noise}} > 100 \text{ mV}$

Noise level "Out of specification": $U_{\text{noise}} > 150 \text{ mV}$

4.4 Fault Detection, Physical Layer Diagnostics

The device coupler can monitor the important physical layer parameters for each participating field device, e. g., communication signal levels and signal jitter. The monitored values are compared to fixed-limit values derived from the IEC 61158-2 physical layer specification or from empirical data.

After a fault or deviation has been detected, a single yellow LED serves as fault indicator at the respective device coupler. For more information

Using Pepperl+Fuchs "Advanced Physical Layer" solutions, e. g., the diagnostic module HD2-DM-A, show the diagnostic state of the individual device in the specific working environment of the control system. For more information, consult the documentation of the respective diagnostic product.

4.4.1 Device Signal Level

In order to detect the following kind of faults or problems, device signal level monitoring and diagnosis are important:

- Incorrect segment termination
- Improper trunk or spur wiring
- Loose wires
- Water ingress in the device coupler or field instrument housing

The monitoring alarm setpoints are:

Signal level 'Maintenance required':	$U_{pp} \leq 300 \text{ mV}$ or $U_{pp} \geq 1200 \text{ mV}$
Signal level 'Out of Specification':	$U_{pp} \leq 200 \text{ mV}$ or $U_{pp} \geq 1300 \text{ mV}$

Where **U_{pp}** is the peak-to-peak signal level

4.4.2 Device Signal Jitter

The device signal jitter is the deviation from the ideal timing of the communication signal. In fieldbus technology, jitter is the deviation of the ideal zero crossing point of the transmitted signal curve during the nominal bit duration. This deviation is measured in relation to the previous zero crossing, i. e., the reference event.

The device signal jitter is the most important parameter to monitor where the noise can influence the signal.

The monitoring alarm setpoints are:

Jitter level "Maintenance required":	$t \geq 3.5 \text{ } \mu\text{sec}$ and $t \leq 5 \text{ } \mu\text{sec}$
Jitter level "Out of Specification":	$t \geq 5 \text{ } \mu\text{sec}$

Where **t** is the jitter error in time

4.5 Fault Isolation

4.5.1 FieldBarrier Self-Diagnostics

The FieldBarrier continually monitors the critical parts of its internal electronic circuits to determine its availability or integrity and that of the spur outputs. When any deviation from normal operation is detected, an alarm is sent to the Advanced Physical Layer Diagnostic Module of the Power Hub. The module transmits the alarm to the system's maintenance or operator station, with the Pepperl+Fuchs Advanced Diagnostic Manager software running.

4.5.2 Short Circuit Current Limitation (Static Fault Protection)

The spur short circuit current limitation is designed to protect the entire segment from failing by limiting the spur current from a direct short circuit (static protection). If the short circuit current condition exceeds a specified period, the spur is automatically isolated from the trunk, i. e., it does no longer receive any current.

4.5.3 Spur Contact Bounce Protection (Dynamic Fault Protection)

Periodic or intermittent changes in the current drawn throughout a segment can cause continuous communication failures up to a point where the segment fails. Changes in the spur current can occur during connection and disconnection of the spur wires or due to fractured or loose wires under vibration.

Conventional spur protection is only designed to protect the segment by limiting the spur current from a direct short circuit (static protection). It does not protect the segment from periodic or intermittent low-level changes in the segment current (dynamic protection).

Under vibration, insufficiently attached, fractured, or loose fieldbus wires keep connecting and disconnecting to the attached field device load. Because the spur is connected to one field device, the current does normally not increase to a value that exceeds the short circuit current. Such intermittent current disturbances are converted into corresponding voltage effects on the trunk. This could cause a temporary or total loss of communication, even leading to the loss of the segment.

The Pepperl+Fuchs Spur Contact Bounce Protection isolates a faulty spur from the segment to prevent segment failures caused by intermittent faults that are not detected by conventional spur protection device couplers.

4.5.4 Progressive Spur Short Circuit Current Limitation (Creeping Fault Protection)

Conventional spur protection circuits are designed to prevent segment failures during fast current changes above the rated short circuit current (direct short circuits).

Failure situations, where the spur current progressively increases, cause the current limiting electronics to dampen the communication signals due to its increasing impedance. A typical failure situation is water in the terminal arrangement with increasing conductivity between the fieldbus wires.

Oscillation sometimes occurs when a fault current is marginally above the current limiting setpoint and the electronic circuit is just operating. At this point, the voltage to the fault decreases with a resulting decrease in current that turns off the current limiting circuit. This cycle continues quite rapidly and can be amplified when a device is transmitting at the same time. The reaction during this narrow transition point is unpredictable because not every fault behaves in a repeatable way. For example, the impedance of water vs. voltage or current can be very non-linear, with the impedance further varying due to the possible impact of temperature and conductivity.

The following example shows the criticality of such a fault scenario:

A field instrument with an active backup – a Link Active Scheduler (LAS) – loses communication to a host in the control room. This situation is due to the low communication signal during a progressing fault condition. The backup LAS now activates while the host LAS remains active. At this point, field instruments at normally operating spurs still ‘see’ the backup LAS which is nearby, as well as the host.

With 2 active LAS on the segment, communication clashes and the segment fails.

Pepperl+Fuchs offers the Progressive Spur Short Circuit Current Limitation that detects slowly increasing spur current and isolates the faulty spur from the segment to prevent segment failures.

4.5.5 Device Jabber Protection

Specific software or hardware failures can cause a field instrument to communicate continuously (Jabber). In this event, the device should disconnect itself from the segment immediately.

The international fieldbus standard IEC61158-2 requires that a field instrument contains a ‘Jabber Inhibit’ circuit or ‘watchdog’. Up to this point, not all currently available instruments support or contain the ‘Jabber Inhibit’ ‘watchdog’.

The Pepperl+Fuchs device couplers have a spur dependent ‘Jabber Inhibit’ feature to isolate a faulty field instrument from the segment in such events.

4.6 Surge Protection

Optional surge protection modules for the trunk and spur cable are available. They are used for safeguarding the device coupler electronics against excessive surges and overvoltages.

The SCP-LBF-IA.36.IE* spur modules replace the spur connectors where surge protection at the spur level is required.

Solid ground bars, ACC-LBF-EB6, are used for routing the ground connections from the individual surge modules together.

Surge Protectors contain a diagnostic function that predicts their failure, before fieldbus communication or the segment voltages are adversely affected.

Surge protection electronics tolerate a number or frequency of activations at given voltage levels until they eventually fail. During this time, the surge protection electronics gradually degrade. The integral diagnostic function compares the overvoltage events to a given algorithm. This way, the function can predict how many more overvoltage events are tolerable until the surge protection electronics has reached the 'end of effective life'. Once this point has been reached, the diagnostic function issues an alarm to the Pepperl+Fuchs Advanced Diagnostics infrastructure. The alarm is transmitted to the Pepperl+Fuchs 'Advanced Diagnostic Manager' software running on the system maintenance or operator workstation. Additionally, the Surge Protector issues a visual alarm to help identify the failing unit or units quickly.

For detailed information, refer to the respective Surge Protector(s) manual(s).

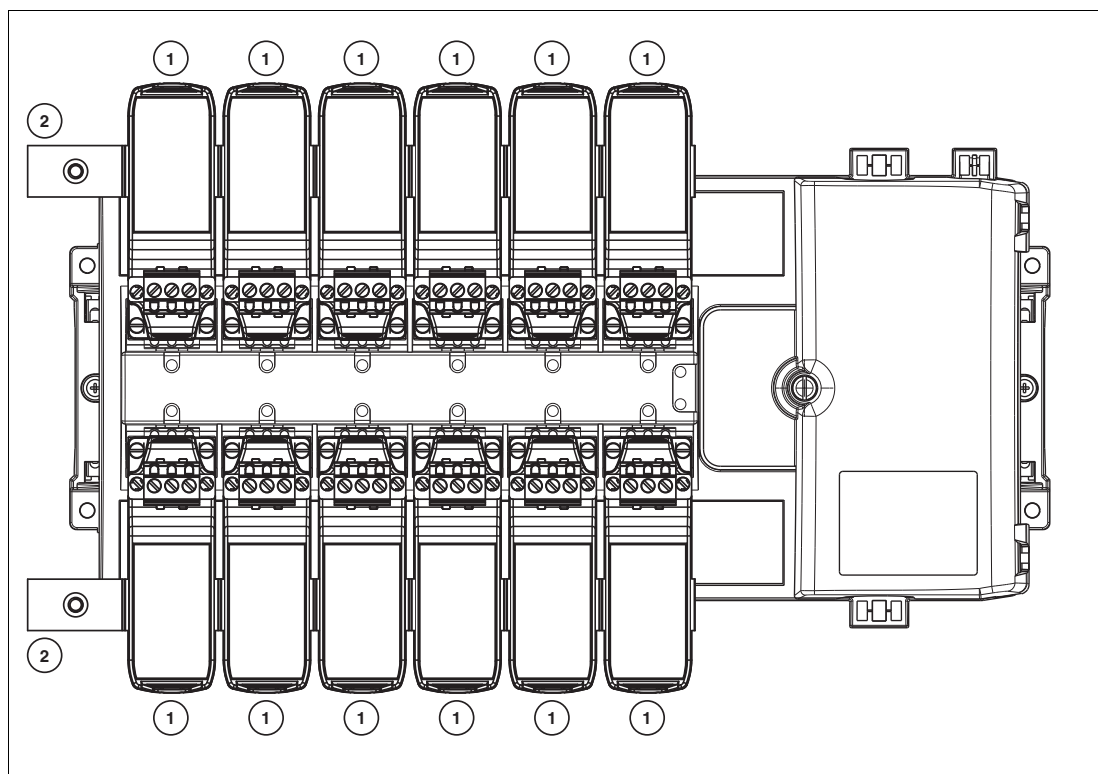

- 1 Surge Protector SCP-LBF-IA1.36.IE*
- 2 Earth bar ACC-LBF-EB.6

4.7 Accessory: Enclosure Leakage Sensor ELS-1

The FieldConnex® enclosure leakage sensor ELS-1 contains a diagnostic function to detect water ingress breaches inside housings early. ELS-1 warns of water ingress before it can adversely affect fieldbus communication, demand high current levels or cause galvanic corrosion damage to electronics. Compactly designed ELS-1 fits into most of today's existing field device housings.

The sensor is designed for use in fieldbus communication topologies according to IEC 61158-2. ELS-1 conforms to the intrinsically safe FISCO and Entity concepts and to IEC 60079-11. As an associated apparatus, ELS-1 can be attached to any fieldbus trunk or spur that is intrinsically safe certified.

ELS-1 can be connected in parallel to the spur output cables of Pepperl+Fuchs device couplers types R2-SP-IC*, F2-SP-IC*, and R4D0-FB-*. Powered by the spur, ELS-1 requires less than 6 mA for operation.

Once water is detected, the diagnostic function inside ELS-1 issues an alarm to the Pepperl+Fuchs Advanced Diagnostics infrastructure. The alarm is transmitted to the Pepperl+Fuchs 'Advanced Diagnostic Manager' software running on the systems maintenance or operator workstation.

Additionally, ELS-1 issues a visual alarm to help identify the affected device/housing or validate the error.

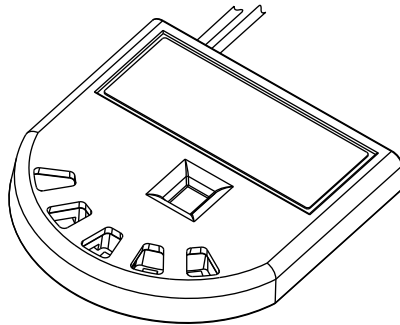

4.8 Using Device Couplers in PROFIBUS PA Installations

You need to take special precautions for installations operating under the following conditions:

- With a high level of environmental impact
- With vibration or shock
- With field devices connecting or disconnecting regularly during operational conditions

The following precautions are necessary to decrease consecutive failures that cause a PROFIBUS PA segment to fail:

- Regularly check that the terminal connections of the device coupler are tightened correctly
- Increase the RETRY LIMIT parameter of the PROFIBUS master to a minimum of 4
Note: When using the Pepperl+Fuchs Segment Coupler HD2-GT* series, the default value of the RETRY LIMIT is already set to 4.
- In order to disconnect a field device, ensure to adhere to the following sequence:
 1. Unplug the corresponding connector at the device coupler
 2. Unscrew the fieldbus wires at the field device

4.9 Using Device Couplers in FOUNDATION Fieldbus H1 Installations

You need to take special precautions for installations operating under the following conditions:

- With a high level of environmental impact
- With vibration or shock
- With field devices connecting or disconnecting regularly during operational conditions



The following precautions are necessary to decrease consecutive failures that cause a FOUNDATION Fieldbus H1 segment to fail:

- Regularly check that the terminal connections of the device coupler are tightened correctly
- Increase the STALE_COUNT_LIMIT parameter of the FOUNDATION Fieldbus LAS or host used to a minimum of 2
- In order to disconnect a field device, ensure to adhere to the following sequence:
 1. Unplug the corresponding connector at the device coupler
 2. Unscrew the fieldbus wires at the field device

5 Appendix

5.1 Ordering Information

Product name	Description
R4D0-FB-IA12.0	FieldBarrier with 12 spur outputs, with pluggable screw terminal connectors for trunk and spurs.
R4D0-FB-IA10.0	FieldBarrier with 10 spur outputs, with pluggable screw terminal connectors for trunk and spurs.
R4D0-FB-IA8.0	FieldBarrier with 8 spur outputs, with pluggable screw terminal connectors for trunk and spurs.
R4D0-FB-IA12.1	FieldBarrier with 12 spur outputs, with pluggable spring cage terminal connectors for trunk and spurs.
R4D0-FB-IA10.1	FieldBarrier with 10 spur outputs, with pluggable spring cage terminal connectors for trunk and spurs.
R4D0-FB-IA8.1	FieldBarrier with 8 spur outputs, with pluggable spring cage terminal connectors for trunk and spurs.
F*-LBF-D1.32	Surge Protector for trunk connection
SCP-LBF-IA1.36.IE.0	Surge Protector for spur connection, shield earthed via GDT.
SCP-LBF-IA1.36.IE.1	Surge Protector for spur connection, diagnostic included, shield earthed via GDT.
ACC-LBF-EB.6	Grounding rail to provide a common earth point and mechanical support for up to six SCP-LBF-1.36* modules.
ELS-1	Enclosure Leakage Sensor for water ingress detection.
MFT-2L.1600 MFT-BASE.4P	Multi Function Terminal MFT-2L.1600 and MFT-BASE.4P for the trunk connection of the FieldBarrier. The MFT allows live disconnect and maintenance in Zone 1 without requiring a hot work permit.

5.2 Electromagnetic Compatibility Verification in Accordance with EC Council Legislation Directive 2004/108/EC

Compatibility in Accordance with EN 61326-1 and NAMUR NE 21 Recommendation

The electromagnetic compatibility – EMC – requirements applicable for electrical equipment for measurement, control and laboratory use in general are anchored in the European Standard EN 61326. 3 different performance criteria are distinguished in this standard:

A category **A** device operates as intended during the test. This device can withstand the immunity tests without any noticeable performance degradations within the specification limits of the manufacturer.

A category **B** device operates as intended after the test. The device shows temporary degradation or loss of function of performance during the test but self-recovers from that state when the exposures are ceased.

A category **C** device has loss of function, may need manual restoration. During the test a temporary loss of function is allowed as long as an operator can restore the device back to operation.

The requirements of the association for standard and control and regulations of the German chemical industries, defined in the NE 21 recommendation, are partly higher compared to the test levels and failure criteria defined in EN 61326-1. For the product qualification, failure criteria and test levels have been selected, always representing the worst case conditions.

2014-10

EN 61000-4, as a generic standard, defines the test setups for the specific required test for EN 61326-1 and NE 21.

See declaration of conformity for standards and editions applied.

Conducted EMC Tests

Immunity

Standard	Type	Test Level	Category
EN 61000-4-2	Electrostatic discharge, direct contact	6 kV	A
	Electrostatic discharge, indirect, air	8 kV	A
EN 61000-4-3	Electromagnetic field radiated, radio frequency	10 V/m	A
EN 61000-4-4	Fast transients burst on signal lines	1 kV	A
	Fast transients burst on power lines	2 kV	A
EN 61000-4-5	Slow transient surge on signal lines	1 kV	B
	Slow transient surge on shielded lines	2 kV	B
EN 61000-4-6	Conducted immunity, radio frequency	10 V	A
EN 55011	RF conducted emission	Class A	–
	RF radiated emission	Class A	–





PROCESS AUTOMATION – PROTECTING YOUR PROCESS



Worldwide Headquarters

Pepperl+Fuchs GmbH
68307 Mannheim · Germany
Tel. +49 621 776-0
E-mail: info@de.pepperl-fuchs.com

For the Pepperl+Fuchs representative
closest to you check www.pepperl-fuchs.com/contact

www.pepperl-fuchs.com

Subject to modifications
Copyright PEPPERL+FUCHS • Printed in Germany

 **PEPPERL+FUCHS**
PROTECTING YOUR PROCESS

/ TDOCT-3161C_ENG
10/2014