

MANUAL

UC***-F77 Series

Configuring Ultrasonic Sensors with IO-Link Interface

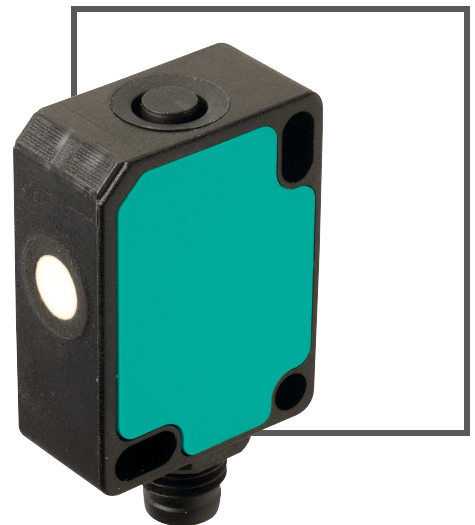

With regard to the supply of products, the current issue of the following document is applicable: The General Terms of Delivery for Products and Services of the Electrical Industry, published by the Central Association of the Electrical Industry (Zentralverband Elektrotechnik und Elektroindustrie (ZVEI) e.V.) in its most recent version as well as the supplementary clause: "Expanded reservation of proprietorship"

1	Introduction.....	7
1.1	Content of this Document	7
1.2	Target Group, Personnel.....	7
1.3	Symbols Used	7
1.4	Intended Use	8
1.5	General Safety Notes	8
1.6	Declaration of Conformity	9
2	Product Description	10
2.1	Use and Application.....	10
2.2	Displays and Local Controls	12
2.3	Accessories	13
2.3.1	Accessories for Mounting and Connection.....	13
2.3.2	Configuration Aids	14
3	Installation.....	15
3.1	Safety Information.....	15
3.2	Preparation	15
3.3	Mounting.....	15
3.4	Connection	16
4	Commissioning without IO-Link.....	17
5	Sensor Programming via the Programming Button.....	18
5.1	Programming Switch Points/Limits.....	18
5.2	Programming Sensor Operating Modes (Sensor with Switching Output)	19
5.3	Programming the Sensor Operating Modes (Sensor with Analog Output)	20
6	Commissioning with IO-Link Using PACTware and DTM	22

7	Configuration and Analysis with DTM via IO-Link.....	25
7.1	Overview.....	25
7.2	Sensor Information Menu Option.....	26
7.3	Output Configuration Menu Item	26
7.4	Sensor Configuration Menu Option.....	27
7.5	Analysis & Echo Suppression Menu Option.....	29
7.6	Observation Menu Option.....	37
7.7	Service Menu Option.....	42
7.8	Information Menu Option.....	43
8	Description of Sensor Parameters.....	44
8.1	Sensor Information.....	44
8.2	Output – Switching Output.....	44
8.2.1	Output Mode	44
8.2.2	Output Logic.....	47
8.2.3	Output Type.....	47
8.2.4	Switch Point 1	47
8.2.5	Switch Point 2.....	48
8.2.6	Retroreflective Mode Offset.....	48
8.2.7	Switching Hysteresis	49
8.2.8	Switch-On Delay	49
8.2.9	Switch-Off Delay	50
8.3	Output Configuration – Analog Output	50
8.3.1	Output Mode	50
8.3.2	Output Type.....	50
8.3.3	Near Limit.....	51
8.3.4	Far Limit	51
8.3.5	Lower Output Value.....	51
8.3.6	Upper Output Value.....	52

8.4	Sensor Configuration – Evaluation	52
8.4.1	Sound Beam Width.....	52
8.4.2	Echo Evaluation	53
8.4.3	Evaluation Method	54
8.4.4	Averages & Skip Count.....	55
8.4.5	Weighting of Former Measurement.....	55
8.4.6	Allowed Deviation to the Former Measurement.....	56
8.4.7	Skip Time.....	56
8.4.8	Temperature Compensation.....	57
8.4.9	Operating Temperature	58
8.4.10	Foreground Suppression	58
8.4.11	Background Suppression.....	58
8.4.12	Sensor Cycle Time.....	59
8.4.13	Ultrasonic Pulse Length	59
8.5	Sensor Configuration – Synchronization.....	60
8.6	Sensor Configuration – Echo Loss and Error Handling.....	61
8.6.1	No Echo.....	61
8.6.2	Output Behavior if an Error Occurs	61
8.6.3	Error Replacement Value – Current/Voltage.....	62
8.7	Sensor Configuration – Local Controls	62
8.7.1	Local Controls.....	62
8.7.2	Local Controls Status	63
8.8	Service	63
8.8.1	Locator Indication	63
8.8.2	"Reset to Factory Defaults" Button	63
9	Synchronizing Multiple Sensors	64
10	Maintenance and Repair	66
10.1	Maintenance Work	66
10.2	Cleaning	66
10.3	Resetting to the Factory Default.....	66
11	Troubleshooting.....	67
11.1	What to Do in Case of an Error	67



12 Appendix	68
12.1 IO-Link Device Parameters	68

1 Introduction

1.1 Content of this Document

This document contains information required to use the product in the relevant phases of the product life cycle. This may include information on the following:

- Product identification
- Delivery, transport, and storage
- Mounting and installation
- Commissioning and operation
- Maintenance and repair
- Troubleshooting
- Dismounting
- Disposal



Note!

Visit www.pepperl-fuchs.com to access further documentation for full information about the product.

The documentation comprises the following parts:

- This document
- Datasheet

In addition, the documentation may comprise the following parts, if applicable:

- EU-type examination certificate
- EU declaration of conformity
- Attestation of conformity
- Certificates
- Control drawings
- Instruction manual
- Other documents

1.2 Target Group, Personnel

Responsibility for planning, assembly, commissioning, operation, maintenance, and dismounting lies with the plant operator.

Only appropriately trained and qualified personnel may carry out mounting, installation, commissioning, operation, maintenance, and dismounting of the product. The personnel must have read and understood the instruction manual and the further documentation.

Prior to using the product make yourself familiar with it. Read the document carefully.

1.3 Symbols Used

This document contains symbols for the identification of warning messages and of informative messages.

Warning Messages

You will find warning messages, whenever dangers may arise from your actions. It is mandatory that you observe these warning messages for your personal safety and in order to avoid property damage.

Depending on the risk level, the warning messages are displayed in descending order as follows:



Danger!

This symbol indicates an imminent danger.

Non-observance will result in personal injury or death.



Warning!

This symbol indicates a possible fault or danger.

Non-observance may cause personal injury or serious property damage.



Caution!

This symbol indicates a possible fault.

Non-observance could interrupt the device and any connected systems and plants, or result in their complete failure.

Informative Symbols



Note!

This symbol brings important information to your attention.



Action

This symbol indicates a paragraph with instructions. You are prompted to perform an action or a sequence of actions.

1.4

Intended Use

The UC***-F77 series ultrasonic sensors use ultrasonic pulses to detect objects. The sensor emits ultrasound which is reflected by the object and received again by the sensor. The measured sound propagation time is used to determine the distance to the object (pulse-echo principle). Objects in the following forms can be detected: solid, granular, powder, or liquid. The color and surface structure of the objects are irrelevant. Gases cannot be detected.



Note!

UC***-F77 series ultrasonic sensors are not safety components within the meaning of the EC Machinery Directive 2006/42/EC. They must not be used for the purposes of avoiding risk to individuals or parts of the body.

Always operate the device as described in these instructions to ensure that the device and connected systems function correctly. The protection of operating personnel and plant is guaranteed only if the device is operated in accordance with its intended use.

Responsibility for compliance with locally-valid safety regulations is borne by the operator.

Only use recommended original accessories.

1.5

General Safety Notes

Responsibility for planning, assembly, commissioning, operation, maintenance, and dismantling lies with the plant operator.

Installation and commissioning of all devices may only be performed by trained and qualified personnel.

The device is only approved for appropriate and intended use. Ignoring these instructions will void any warranty and absolve the manufacturer from any liability.

If serious faults occur, stop using the device. Secure the device against inadvertent operation. In the event of repairs, return the device to your local Pepperl+Fuchs representative or sales office.



Note!

Disposal

Electronic waste is hazardous waste. When disposing of the equipment, observe the current statutory requirements in the respective country of use, as well as local regulations.

1.6

Declaration of conformity

This product was developed and manufactured under observance of the applicable European standards and guidelines.



Note!

A Declaration of Conformity can be requested from the manufacturer.

The product manufacturer, Pepperl+Fuchs GmbH, D-68307 Mannheim, has a certified quality assurance system that conforms to ISO 9001.



2 Product Description

2.1 Use and Application

The UC***-F77 series ultrasonic sensors use ultrasonic pulses to detect objects. The sensor emits ultrasound which is reflected by the object and received again by the sensor. The measured sound propagation time is used to determine the distance to the object (pulse-echo principle). Objects in the following forms can be detected: solid, granular, powder, or liquid. The color and surface structure of the objects are irrelevant. Gases cannot be detected.



Figure 2.1 Example of application: film monitoring on a packaging machine

Typically, ultrasonic sensors are used in a wide range of applications including:

- Sag control on packaging and metal processing machines
- To measure diameter of roll material (e.g., film, paper, metal sheet)
- To detect fill levels in tanks and silos
- To avoid collisions with self-propelled or controlled machines
- Height control of booms for sprayers
- To detect containers on refuse collection vehicles
- To detect objects or to measure fill levels on conveyor belts
- To detect pallets on forklift trucks
- To monitor range on barrier systems
- To detect PCBs when feeding them to SMD placement machines

The F77 compact housing design can be programmed and so adapted to various applications. You can program limits, output mode, output type, and sound beam width via the programming button on the sensor or the convenient IO-Link interface. Programming via the IO-Link also provides the option of setting many other parameters such as filter options, echo suppression, synchronization settings,...

The IO-Link versions with switching output enable IO-Link communication in accordance with the IO-Link standard. The F77 versions with analog output can be configured via their IO-Link interface but are not designed for long-term IO-Link operation.

The advantages of the UC***-F77 series ultrasonic sensors are:

- Compact housing design
- Advanced setting options via programming button on the device
- IO-Link 1.1 interface for service and process data, and for parameterization
- Excellent immunity to background noise such as compressed air
- Can be self-synchronized to avoid mutual interference of several adjacently mounted ultrasonic sensors
- Programmable echo suppression
- Also available as sidelooker version with M18 mounting option and higher detection range

What is IO-Link?

IO-Link is a new dimension in the communication of and with sensors. The possibility of making the intelligence that is already integrated in each and every sensor fully available to users opens up new possibilities for automation. Using IO-Link brings specific advantages to all areas of application in the field of factory automation; in service (fault elimination, maintenance, and device replacement), during commissioning (cloning, identification, configuration, and localization) or in operation (job changes, continuous parameter monitoring, and online diagnostics). Reducing the variety of interfaces offers users significant savings potential. This variety of interfaces often results from having analog sensor inputs and the complex installation required in this case.

Device description file (IODD)

The sensor parameters are different for each device. These parameters are described in a standardized format in the device description IODD (IO Device Description). The IODD can be imported into various engineering tools from different system providers, providing they support IODD. The sensor can be configured or diagnosed using the appropriate tool.

You can also transform the IODD via the "IODD DTM Configurator" to configure via a tabular user interface. We recommend "PACTware" software as the user interface in which you can load the transformed IODD. It is also possible to use equivalent software.

You can find the device description file (IODD) which is necessary for connecting to an IO-Link system online at www.pepperl-fuchs.com on the product page for the relevant UC***-F77-...

DTM (Device Type Manager)

If a sensor is not used long-term in an IO-Link environment, but nevertheless needs to be configured, this can be done easily via a PC with installed FDT framework application (e.g., PACTware) and with the DTM (Device Type Manager, a kind of "device driver") available for the sensor. Unlike configuration via the IODD, this method provides extended functions and ensures improved graphic visualization and convenient operation. Functions such as UC***-F77 series "echo suppression" can only be configured via the relevant DTM.

2.2 Displays and Local Controls

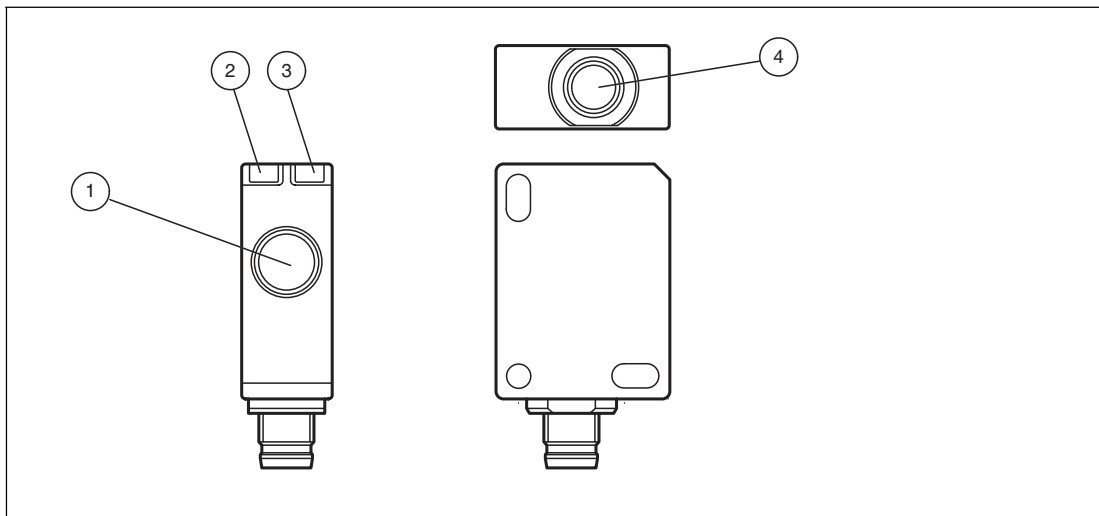

Figure 2.2

1. Sonically-active area
2. Yellow LED
3. Green/red LED (Duo LED)
4. Programming button

LED display for sensors with switching output

	Green LED	Yellow LED	Red LED
In normal operation			
Error-free operation	On	Switching state	Off
Fault (e.g., compressed air)	Off	Retains previous state (factory default setting, can be changed via IO-Link)	On
Standby (high level for > 1 s at synchronization input)	Flashing	Retains previous state	Off
When programming the switch points			
Object detected	Off	Flashing slowly	Off
No object detected	Off	Flashing quickly	Off
Unreliable object detection	Off	Off	Flashing
Confirmation of successful programming	Flashes 3x	Off	Off
Warning in the event of invalid programming	Off	Off	Flashes 3x
When programming operating modes			
Programming output mode	Flashing	Off	Off
Programming output logic	Off	Flashing	Off
Programming sound beam width	Off	Off	Flashing

Table 2.1

LED display for sensors with analog output

	Green LED	Yellow LED	Red LED
In normal operation			
Error-free operation	On	Output state	Off
Fault (e.g., compressed air)	Off	Retains previous state (factory default setting, can be changed via IO-Link)	On
Standby (high level for > 1 s at synchronization input)	Flashing	Retains previous state	Off
When programming the limits			
Object detected	Off	Flashing slowly	Off
No object detected	Off	Flashing quickly	Off
Unreliable object detection	Off	Off	Flashing
Confirmation of successful programming	Flashes 3x	Off	Off
Warning in the event of invalid programming	Off	Off	Flashes 3x
When programming operating modes			
Programming output mode	Flashing	Off	Off
Programming the output type	Off	Flashing	Off
Programming sound beam width	Off	Off	Flashing

Table 2.2

2.3 Accessories

Various accessories are available.

2.3.1 Accessories for Mounting and Connection

Several components are available for mounting and connecting UC***-F77 series sensors. You will find details online at www.pepperl-fuchs.com on the product page for the relevant sensor or on the relevant datasheet.

The following types of accessories are available for order:

- OMH ML7* mounting aids
- Connection cable and cordset



Note!

For mounting, connection, and commissioning, the following product information is available online at www.pepperl-fuchs.com on the product page for the relevant sensor: datasheet, commissioning manual, manual. The relevant DTM also contains comprehensive context-related help descriptions.

2.3.2 Configuration Aids

The following configuration aids are available:

Designation	Description
PACTware	FDT frame application for operating IODDs and DTMs
Pepperl + Fuchs PACTware Connection Wizard	Wizard for simple project and connection set-up of the ultrasonic sensor in PACTware. Visit www.pepperl-fuchs.com and the product page for the relevant UC***-F77 series sensor.
IODD for UC***-F77*	IODD (IO Device Description) – device description for operating the sensor, integration in the system environment Visit www.pepperl-fuchs.com and the product page for the relevant UC***-F77 series sensor.
DTM for UC***-F77*	DTM (Device Type Manager) – device description and graphic user interface for operating the sensor, integration into the system environment Visit www.pepperl-fuchs.com and the product page for the relevant UC***-F77 series sensor.
IODD Interpreter DTM	Software for integrating IODDs in an FDT frame application (e.g., PACTware)
IO-Link-Master02 USB	"USB-IO-Link-Master02" adapter box for direct control of an IO-Link sensor via a PC, M12 connection for sensor
V31-GM-1M-PVC-V1-G	Connection cable, M8 to M12, for connecting a UC***-F77 series sensor to the IO-Link-Master02 USB
IO-Link-Master-USB DTM	Device Type Manager – software for operating the IO-Link-Master02 USB via FDT

Table 2.3

3 Installation

3.1 Safety Information



Caution!

Risk of short circuit

Carrying out work while the system is energized may result in damage to the device.

- Always disconnect the supply voltage before carrying out work on the device.
- Only connect the device to the supply voltage once all work has been completed.

3.2 Preparation



Unpacking the unit

1. Check that all package contents are present and undamaged.
 - ↳ If anything is damaged, inform the shipper and contact the supplier.
2. Check that all items are present and correct based on your order and the shipping documents.
 - ↳ If you have any questions, please contact Pepperl+Fuchs.
3. Keep the original packing material in case you need to store or ship the unit at a later time.

3.3 Mounting



Note!

Mounting instructions for UC400-F77... sensors

To ensure a reliable function of UC400-F77... sensors at operating temperatures below 0 °C, you need to mount the enclosed plastic mounting base between the sensor housing and mounting rack.



Mounting UC***-F77 sensors

Use M3 cylinder head screws to secure the sensor and tighten to a maximum torque of 0.2 Nm.

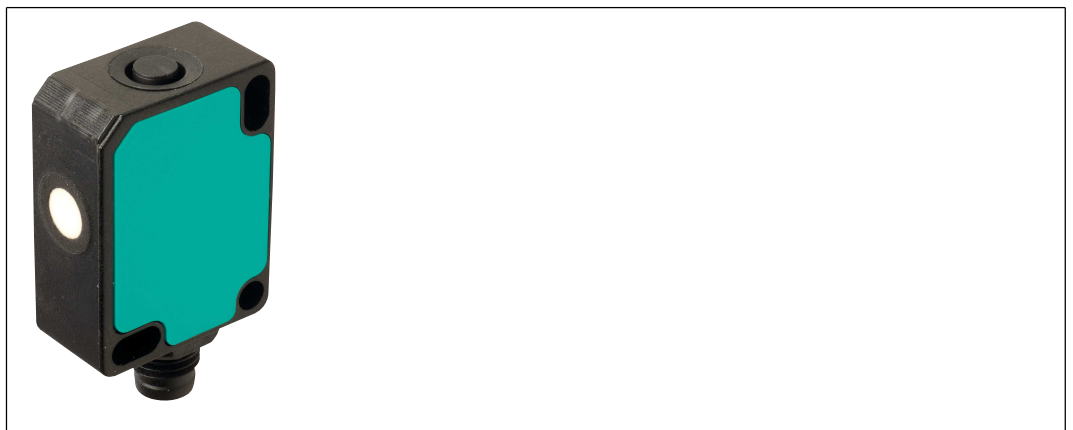

Figure 3.1



Mounting UC***-F77S sensors

F77S sensors can be secured using either M3 cylinder head screws or an M18 nut.

Tighten the M3 cylinder head screws with a maximum torque of 0.2 Nm. Tighten the M18 nut with a maximum torque of 1 Nm.

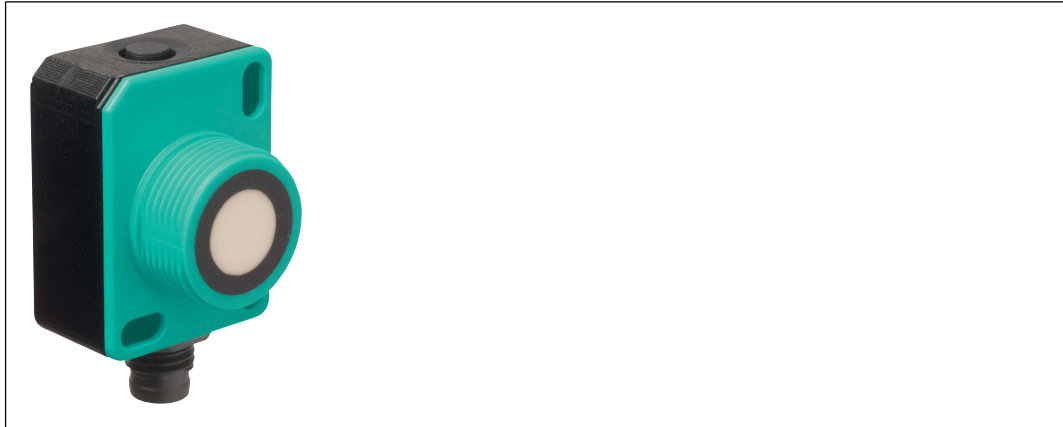

Figure 3.2

3.4 Connection



Note!

If the synchronization option is not used, the synchronization input must be connected to ground (0 V).



Applying supply voltage for a sensor with connector plug

To supply voltage to the sensor, proceed as follows:

1. Insert the prepared connection cable into the connector plug provided for this purpose on the underside of the housing.
2. Screw the cap nut onto the connector plug as far as it will go. This ensures that the power cable cannot be inadvertently pulled out.
3. Now connect the supply voltage to the cable provided for this purpose and switch it on.
 - ↳ The sensor is now ready for operation.



Applying supply voltage for a sensor with connection cable

To supply voltage to the sensor, proceed as follows:

1. Connect the sensor connection cable to your control environment.
2. Switch on the supply voltage for the sensor.
 - ↳ The sensor is now ready for operation.



Control via IO-Link

To prepare the sensor for control via IO-Link, proceed as follows:

Connect the sensor to an IO-Link master. For a sensor with connector plug, screw the cap nut onto the connector plug as far as it will go. Use a 4-wire or 5-wire sensor cable for the connection.

↳ The sensor is now prepared for IO-Link communication.



4

Commissioning without IO-Link



Switch on the supply voltage. The operating indicator on the sensor lights up green.

↳ The sensor will now function using the preset parameters.



Note!

It is only possible to change configuration by programming with the programming button or by configuring via IO-Link!

5 Sensor Programming via the Programming Button

Basic information about programming

In terms of factory settings, the sensor can only be programmed during the first 5 minutes after switching on. This time is extended during the actual programming process. The option of programming the sensor is revoked if no programming activities take place for 5 minutes. After this, programming is no longer possible until the sensor is switched off and on again.

When configuring sensors via the IO-Link, you can use the DTM to adjust the programming button's locking logic. This is done in the "Sensor configuration" menu option, "Local controls" tab.

When actively communicating via the IO-Link interface of the sensor, it is not possible to use the programming button to program.

The programming activities can be canceled at any time without changing the sensor settings. To do so, press and hold the programming button for 10 seconds.

Programming via the programming button can take place in the stand-alone mode of a sensor or also in the synchronized sensor group of several sensors (only for automatic common mode and multiplex mode). When programming in the synchronized sensor group, there may be a delay to starting the programming routine, depending on when the sensor in question is next in line. For the duration of the programming process, the other sensors in the sensor group go into standby mode (green LED is flashing). Then synchronization mode continues to operate as normal.

5.1 Programming Switch Points/Limits



Note!

Depending on the type of sensor, you can program the switch points for sensors with switching output and the limits for sensors with analog output. The programming procedures are the same in both cases and are therefore described in conjunction below.



Programming Switch Point 1/Near Limit (SP1)

If the object is detected correctly during the programming process, the yellow LED flashes slowly. If no object is detected, the yellow LED flashes at a higher frequency. A flashing red LED during or when completing the programming process indicates unreliable object detection. In this case, correct the alignment of the object during the programming process until the yellow LED flashes. Only then will the settings be transferred to the sensor memory.

1. Position the object at the site of the required switch point/the required near limit.
2. Press and hold the T programming button for 2 seconds (yellow LED flashes)
3. Briefly press the T programming button (green LED flashes 3 times as confirmation). The sensor returns to normal operation.



Programming Switch Point 2/Far Limit (SP2)

1. Position the object at the site of the required switch point/required far limit.
2. Press and hold the T programming button for 2 seconds (yellow LED flashes)
3. Press and hold the T programming button for 2 seconds (green LED flashes 3 times as confirmation). The sensor returns to normal operation.

5.2 Programming Sensor Operating Modes (Sensor with Switching Output)

The sensor features a 3-stage process for programming the sensor operating modes. In this programming routine you can program as follows:

- A) Output mode
- B) Output logic
- C) Sound beam width

These stages of the process are programmed in succession. To switch from one programming step to the next, press and hold the programming button for 2 seconds.

The following graphic illustrates the programming routine:

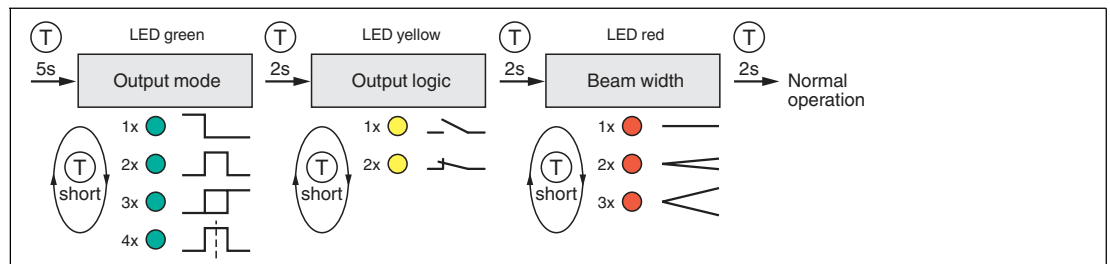

Figure 5.1

▶ Activating the programming routine

To activate the programming routine, press the programming button for 5 seconds until the green LED begins to flash.

▶ Programming output mode

The green LED is now flashing. The number of flashing pulses shows the currently programmed output mode:

- 1x: switch point mode
- 2x: window mode
- 3x: hysteresis mode
- 4x: retroreflective mode

1. Briefly press the programming button to navigate through the output modes in succession. Select the required output mode.
2. Press the programming button for 2 seconds to switch to the next programming step, to adjust the output logic.

▶ Programming output logic

The yellow LED is now flashing. The number of flashing pulses shows the currently programmed output logic:

- 1x: normally-open
- 2x: normally-closed

1. Briefly press the programming button to navigate through the output logic in succession. Use this method to choose the output logic.
2. Press the programming button for 2 seconds to switch to the next programming step, the programming of the sound beam width.

▶ Programming sound beam width

The red LED is now flashing. The number of flashing pulses shows the currently programmed sound beam width:

- 1x: small
- 2x: medium
- 3x: wide

1. Briefly press the programming button to navigate through the sound beam widths in succession. Use this method to choose the required sound beam width.
2. Press and hold the push button for 2 seconds to save all performed settings and to return to normal operation.

5.3 Programming the Sensor Operating Modes (Sensor with Analog Output)

The sensor features a 3-stage process for programming the sensor operating modes. In this programming routine you can program as follows:

- A) Output mode
- B) Output type
- C) Sound beam width

These stages of the process are programmed in succession. To switch from one programming step to the next, press and hold the programming button for 2 seconds.

The following graphic illustrates the programming routine:

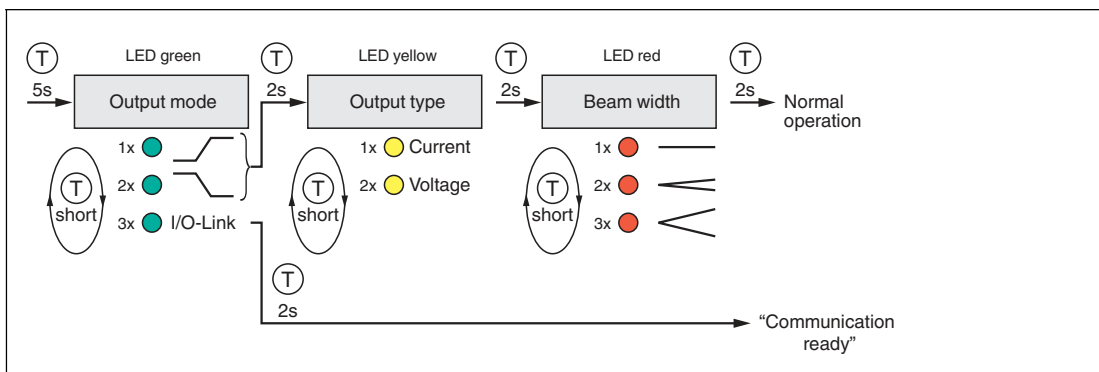

Figure 5.2



Note!

To exit the IO-Link parameter mode in normal operation (analog signal at the output), briefly disconnect the sensor from the power supply.



Activating the programming routine

To activate the programming routine, press the programming button for 5 seconds until the green LED begins to flash.



Programming output mode

The green LED is now flashing. The number of flashing pulses shows the currently programmed output mode:

- 1x: rising ramp
- 2x: falling ramp
- 3x: IO-Link mode (select this mode if you want to communicate with the sensor via IO-Link)

1. Briefly press the programming button to navigate through the output modes in succession. This allows you to select the required output mode.
2. Press the programming button for 2 seconds to change to the next programming step, the selection of the output type.



Programming output logic

The yellow LED is now flashing. The number of flashing pulses displays the currently programmed output type:

- 1x: current output
- 2x: voltage output



1. Briefly press the programming button to navigate through the output types in succession. Select the required output type.
2. Press the programming button for 2 seconds to change to the next programming step, the adjustment of the sound beam width.



Programming sound beam width

The red LED is now flashing. The number of flashing pulses displays the currently programmed sound beam width:

1x: small

2x: medium

3x: wide

1. Briefly press the programming button to navigate through the sound beam widths in succession. Use this method to choose the required beam width.
2. Press and hold the push button for 2 seconds to save all performed settings and to return to normal operation.

6 Commissioning with IO-Link Using PACTware and DTM



Note!

An M8 to M12 connection cable is necessary to connect the sensor to the IO-Link master. You can find suitable connection cables by visiting www.pepperl-fuchs.com and clicking on the product page for the relevant sensor.

There is a DTM available to download to help you fully configure the sensor easily via IO-Link. Visit www.pepperl-fuchs.com and access the product page for the relevant UC***-F77 series sensor.

This manual sets out how to configure using the "PACTware" FDT framework application in which the DTM (Device Type Manager) is loaded. In principle you can use other appropriate FDT framework applications. It is also possible to use the appropriate IO-Link for configuration instead of using the DTM.

The "Pepperl + Fuchs PACTware Connection Wizard" is available to help you launch and connect the sensor easily. The wizard takes you through all the necessary steps for opening a PACTware project. Alternatively you can launch PACTware directly and add or launch devices such as IO-Link master and the sensor as well as the DTM and connection set-up on a step-by-step basis.



Prerequisites for Commissioning

Proceed as follows to communicate with the sensor via IO-Link using "PACTware" software and the associated DTM (Device Type Manager):

1. Make sure that PACTware and the necessary DTMs (Device Type Managers), and the IO-Link device description for the sensor, IO-Link master, and any required communication DTMs for upstream components are installed.
2. Connect the sensor via an M8 to M12 connection cable to an IO-Link master.
3. Connect the IO-Link master via a USB cable to a USB port of your PC.
4. Only for UC-F77 with analog output: Put the sensor into IO-Link mode. Details can be found in the "Programming sensor operating modes (sensor with analog output)" chapter, "Programming output mode" section.

↳ IO-Link mode is switched on if the green LED flashes continuously.

You need to exit IO-Link mode once the sensor has been configured via the DTM. The sensor is not intended for long-term IO-Link operation. To prevent this from happening, briefly disconnect the sensor from the power supply.



Setting Up Sensor Communication using PACTware via "Pepperl + Fuchs PACTware Connection Wizard"

You need to install "Pepperl + Fuchs PACTware Connection Wizard" on your PC and connect the sensor and IO-Link master to the PC.

Double-click the "Pepperl + Fuchs PACTware Connection Wizard" icon.

↳ Loads PACTware and the associated DTM and the connection to the sensor is automatically established.

➤ **Setting Up Sensor Communication using PACTware (Step-by-Step)**

1. Launch PACTware by double-clicking on the PACTware icon.

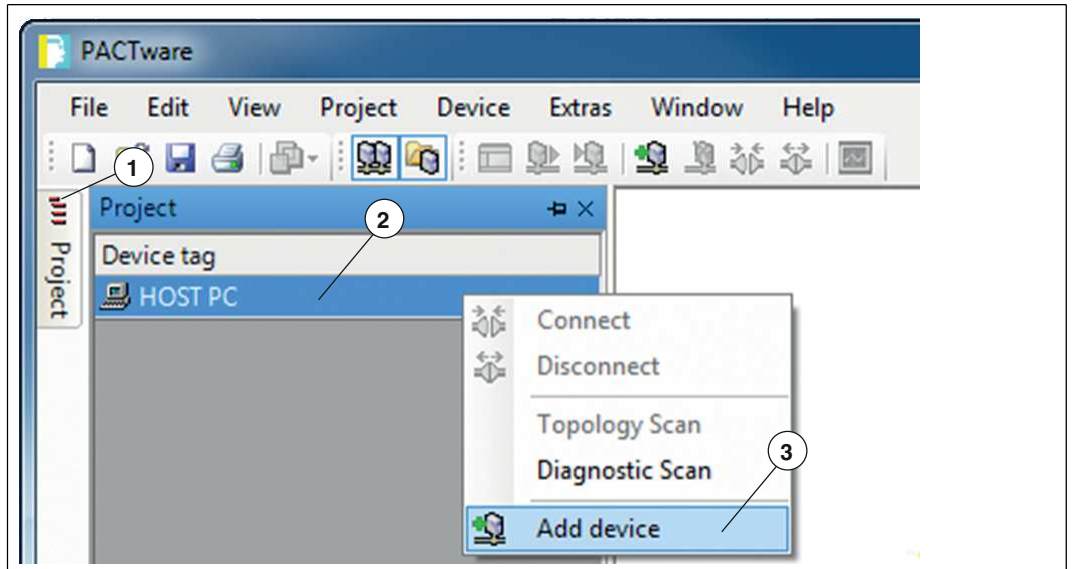

Figure 6.1

2. Click at the top left on **Project** (1).
3. Click on **Host PC** (2), then click the right mouse button and click **Add device** (3).
↳ Displays a window for selecting the device
4. Check "IO-Link USB master..." in the window and confirm with **OK**.
↳ The IO-Link USB master is installed as a device in the project.
5. Click in the project on the **IO-Link USB master...** (4), then click the right mouse button and then on **Add device** in the now extended display.
↳ The window for selecting devices is displayed again with all available DTMs and IODDs.
6. Select the required DTM and use OK to confirm.
↳ The DTM is installed in the project (5) here as example "UC250-F77-EP-IO-V31."

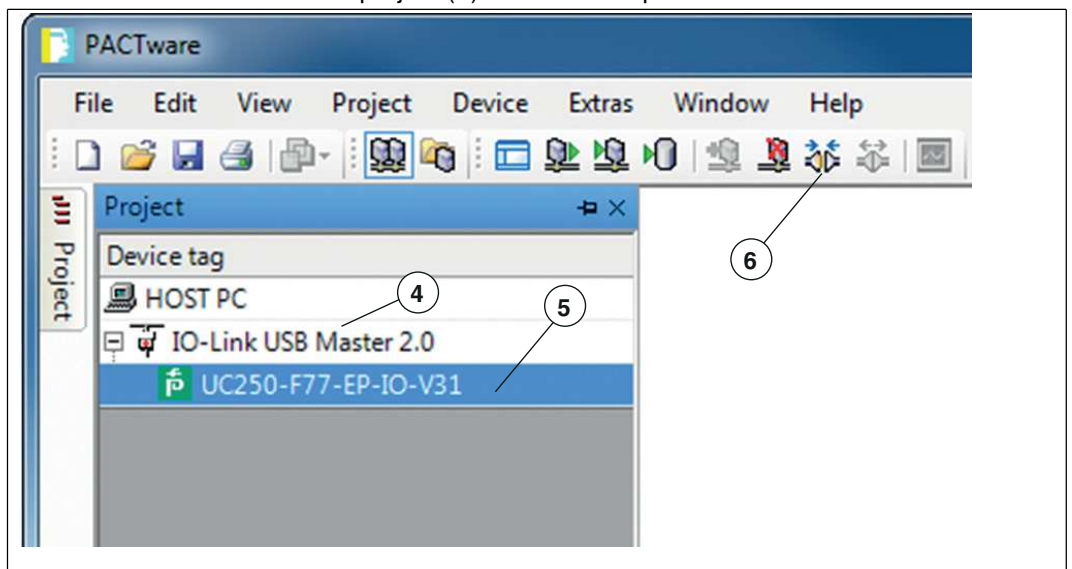

Figure 6.2



7. Double-click in the project on the DTM (5) here as example "UC250-F77-EP-IO-V31."
↳ The selected DTM interface is displayed.
8. Click on the icon to set up the connection (6).
↳ Data connection to the sensor is established. Status information "connected" will be displayed in the bottom left of the menu if connection is successful.

7 Configuration and Analysis with DTM via IO-Link

7.1 Overview

The sensor parameters are different for each device. These parameters are clearly set out in the DTM (Device Type Manager), with guidance being provided in the form of graphics for some of the parameters. The DTM can be imported into various engineering tools from different system providers, providing they support DTM. The sensor can then be configured or diagnosed using the appropriate tool (e.g., PACTware). The DTM menus are outlined below on the basis of the "PACTware" FDT framework application being used.

The DTM (Device Type Manager) set out below provides you with various ways of easily and fully configuring the sensor via IO-Link and analyzing sensor logic.

In addition to configuring the sensor, you can use the **Analysis & Echo suppression** and **Observation** menus to display and record sensor logic in operation in order to adapt it in the best way possible to your application.



Note!

The following DTM screenshots in the PACTware framework program apply to all versions of UC***-F77-...-IO-.. products, taking the UC250-F77-EP-IO-V31 sensor as an example. Individual sensors of the product family vary in terms of the number of switching outputs or in terms of whether they are fitted with or without analog output, for example. Consequently the DTMs of the respective product versions may differ from the following screenshots.

Context-Related Help Texts via F1

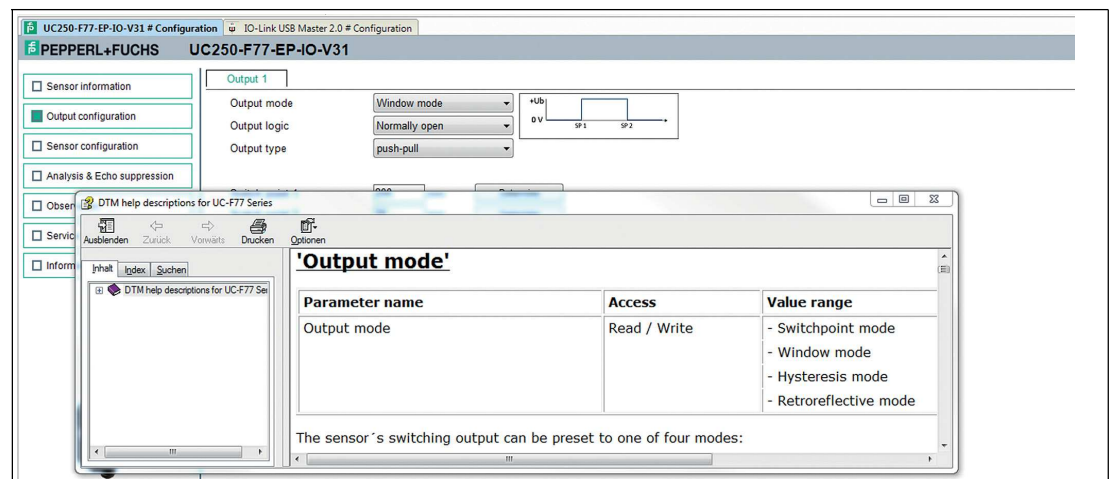

Figure 7.1

In the DTM, you can access context-related help texts by clicking on the "?" icon in the displayed menu or by clicking on the required parameter and then pressing the F1 button. A display will then open showing information about the setting options of the relevant menu and its parameters.

7.2 Sensor Information Menu Option

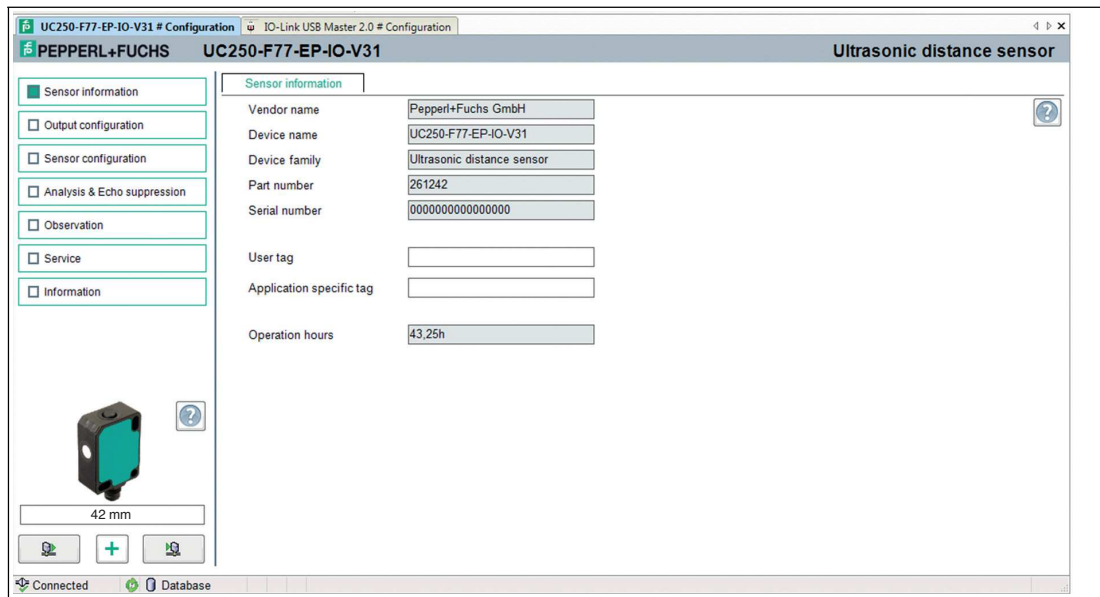

Figure 7.2

Preprogrammed manufacturer and device information is displayed in the **Sensor information**

- menu option, as well as the number of operating hours. These are read-only fields.
- You can input application-specific tags to identify and mark your sensor in the system environment. Text information (string) can be input in the "User tag" and "Application-specific tag" fields.

7.3 Output configuration Menu Item

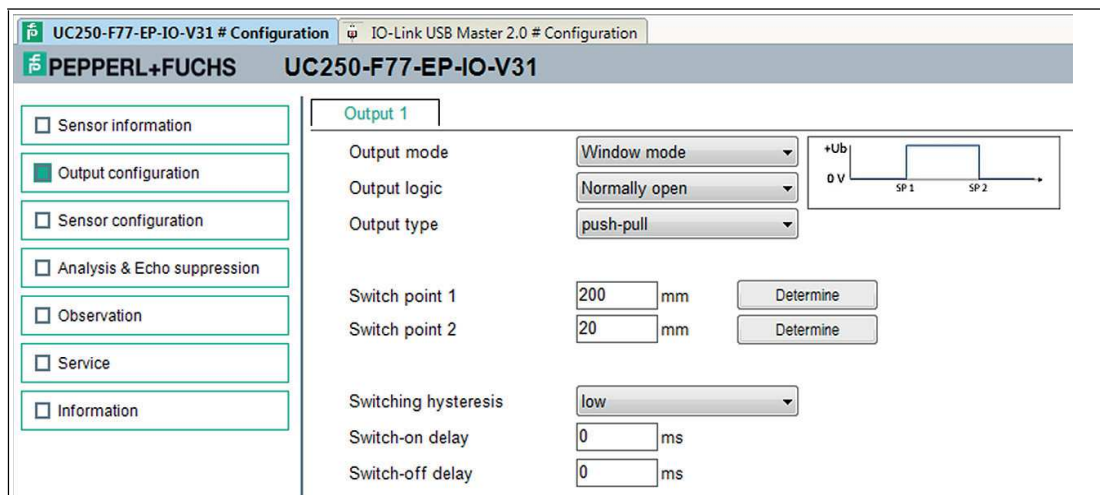

Figure 7.3

In the **Output configuration** menu item you have the possibility to set the output logic and the switching characteristics of the sensor.

7.4 Sensor Configuration Menu Option

Overview of the Sensor Configuration menu option

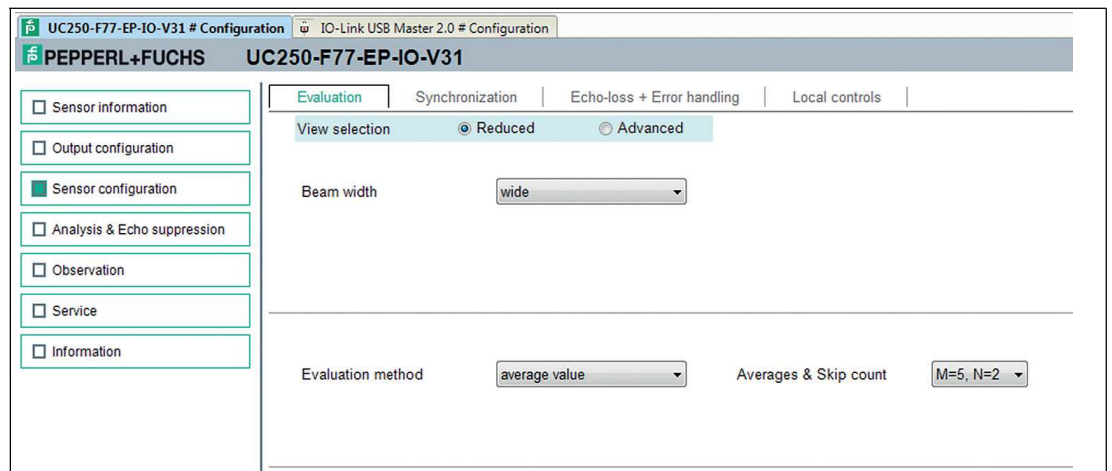

Figure 7.4

The **sensor configuration** menu option consists of 4 tabs

- Evaluation (with reduced and advanced view)
- Synchronization
- Echo loss and error handling
- Local controls

Evaluation tab (advanced view)

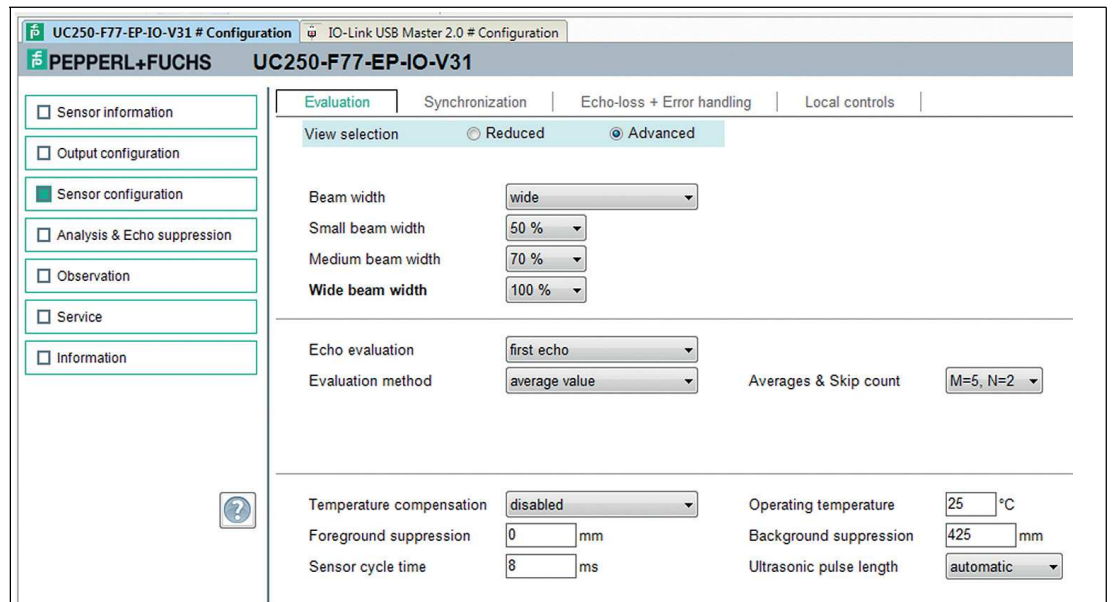

Figure 7.5

In the **Evaluation** tab, you can set the functions which impact evaluation logic with sensor measurement. You can choose between a reduced view for basic settings and an advanced view for evaluation expert settings.

Synchronization tab

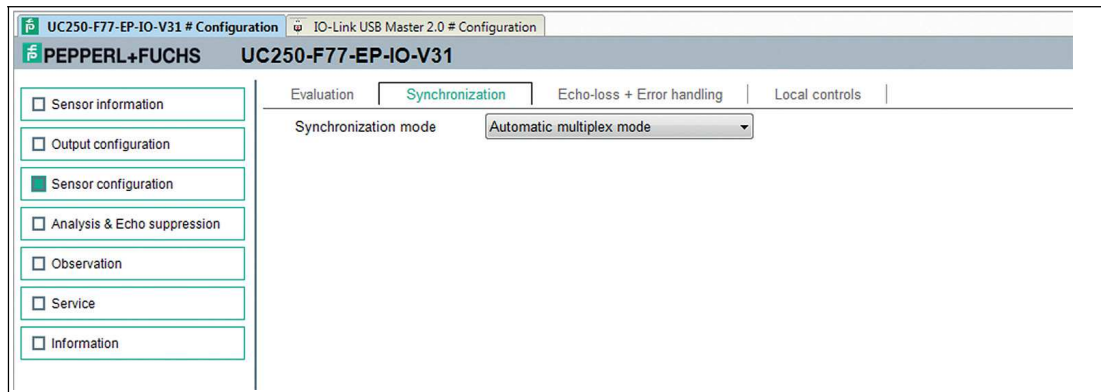

Figure 7.6

In the Synchronization tab, you can set the required synchronization mode if you want to suppress mutual interference when operating several UC***-F77-...-IO-.. sensors. Details of the individual synchronization modes can be found in the chapter "Synchronizing multiple sensors."

Echo loss + Error handling tab

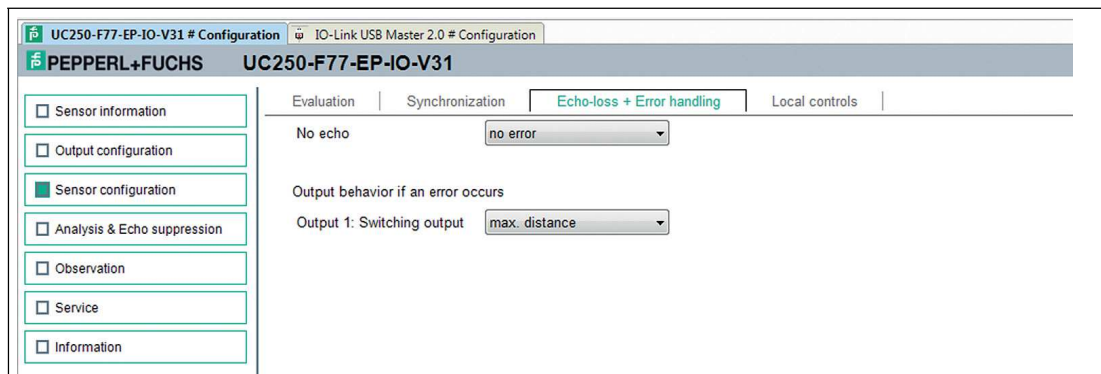

Figure 7.7

In the **Echo loss and error handling** tab, you can adjust the evaluation of a loss of echo and the error output behavior of the sensor output.

Local controls tab

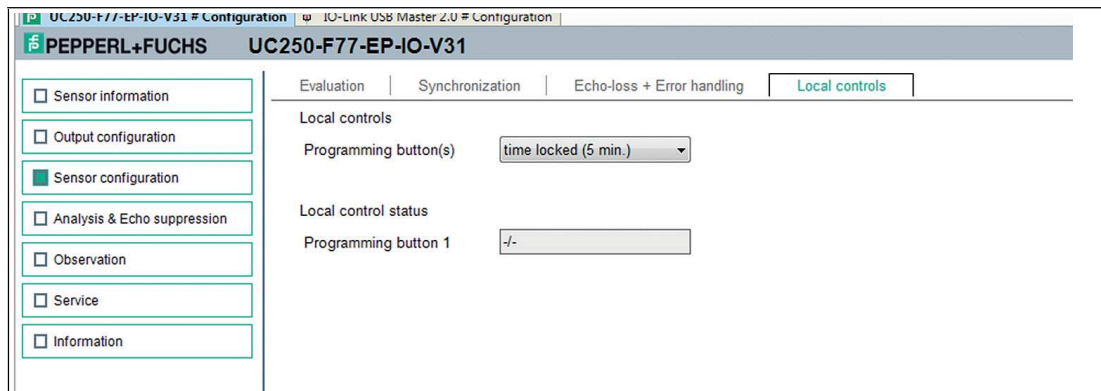

Figure 7.8

In the **Local controls** tab, you can lock or activate the programming button, or use a time lock and display the status of the programming button (pressed/not pressed).

7.5 Analysis & Echo Suppression Menu Option

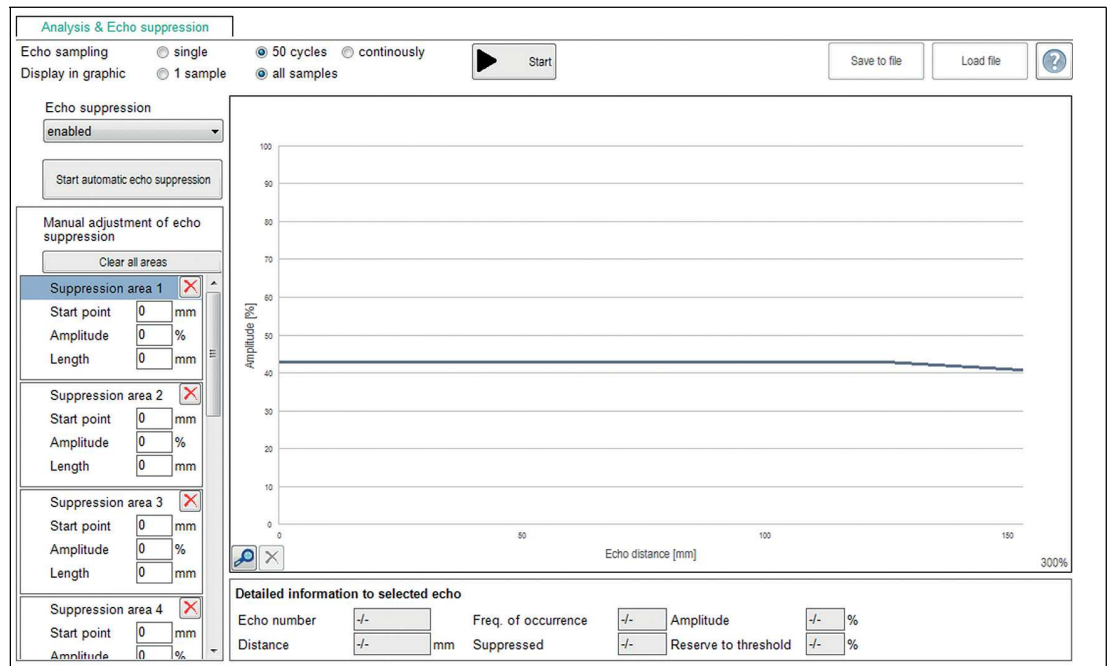

Figure 7.9

In some applications, machine parts or support bars within a tank obstruct the sensing area, preventing proper distance or level measurement. Using the **Analysis & Echo Suppression** menu option, you can visualize and analyze all echoes received by the ultrasonic sensor from one or a series of measurements, as well as suppress the disruptive objects in the sensing area.



The general procedure is as follows:

1. You must first establish a connection to a sensor built into the application environment.
2. Ideally carry out multiple echo samples.
 - ↳ The corresponding data will then be shown in the display together with the switching threshold of the sensor (blue line).
3. Start automatic echo suppression. If necessary, you can correct the suppression areas. Alternatively, you can also manually set the suppression areas.
4. Finally, verify the detected settings by taking fresh echo samples.
 - ↳ The detected settings can be stored to/loaded from a file.

Menu Description

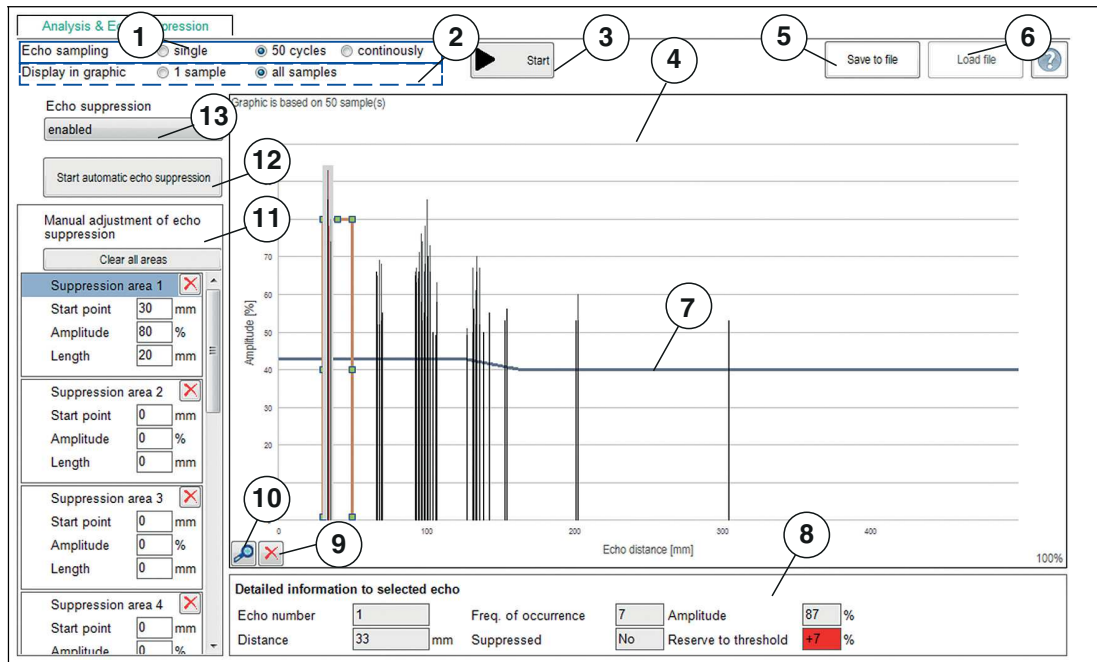

Figure 7.10

No.	Name	Description
1	Echo sampling	In the "Echo sampling" area, you can choose whether to record a single value, 50 values or continuous data. Using the continuous display also provides you with an alignment aid. You can use the displayed amplitude of the evaluated echo to check whether the sensor is optimally aligned to the object. You will know this has worked when slightly varying the alignment no longer increases the displayed echo amplitude.
2	Display in graphic	You can use the "Display in graphic" area to set whether all of the gathered recorded echoes are shown or only the last recorded echo image. The former is recommended if you want to set suppression areas in an application; the latter in order to verify detected suppression areas.
3	Start	The "Start" button is used to start and stop echo sampling. After echo sampling has started, the button changes to "Stop." <ul style="list-style-type: none"> ■ In the case of "individual" echo sampling, echo sampling stops after one measurement. ■ In the case of "50 values" echo sampling, echo sampling automatically stops after 50 measurements. You can stop it at any time by pressing the button. ■ In the case of "continuous" echo sampling, echoes will continue to be sampled until you press the button again.
4	Display area	The sampled echoes are displayed in the form of thin columns during and after completion of echo sampling. The counter in the upper left corner indicates the number of echo samples the current graphic is based on.
5	Save to file	You can save the echo sample, including set suppression areas, as a .CSV file, .XML file or .TXT file by pressing the "Save to file" button. In addition to this data, sensor settings (parameter values) will also be saved. This means it is possible to evaluate recorded data later "offline."

2017-06

No.	Name	Description
6	Load file	You can load previously-saved echo samples to the DTM by pressing the "Load file" button, allowing you to assess or evaluate the samples. Note: You can only load a saved file if disconnected from the sensor.
7	Sensor switching threshold (blue line)	In addition to the recorded echoes, the switching threshold of the sensor will also be displayed as a "blue line." Echoes for which amplitude exceeds this threshold can be evaluated by the sensor. Echoes below the switching threshold are in effect suppressed and are discounted by the sensor during evaluation.
8	Details of the selected echo	Clicking on one of the echo columns shown in the graphic displays detailed information about the selected echo below the graphic. Note: More information on this can be found in the following section "Details about sampled echoes."
9	Clear echo sample	You can use the "Clear echo sample" button to clear the display area and restore to the original state.
10	Rescale diagram	You can use the "Rescale diagram" (magnifying glass) button to enlarge the view along the x-axis 5-fold in 100 % increments. If magnification is set to more than 100 %, the displayed area of the x-axis can be shifted (by scrolling) to be able to obtain a magnified view of sections of the entire sample area. To do so, right-click on the x-axis, keep it pressed and move left or right with the mouse.
11	Manually adjusting the suppression areas	The area allows you to manually set individual suppression areas. 10 areas can be individually customized as well as deleted individually or all at once. Each suppression area is determined by three parameters: "Start point," "Amplitude," and "Length." <ul style="list-style-type: none"> ■ The mm value entered for "Start point" specifies where the suppression area starts on the X-axis of the graph. ■ The % value for "Amplitude" specifies the height of the suppression area in keeping with the scale of the Y-axis. ■ The mm value entered for "Length" specifies the length of the suppression area measured from the respective start point. <p>Individual areas can be cleared by either pressing the relevant button with the red "X" or by going directly to the graphic and clicking on the framed area and pressing the "Del" button on the keyboard. It is necessary to clear a single area, for example, if the echo from the target object is also contained in the echo sample and was also suppressed by automatically setting the suppression areas. All areas can be cleared by pressing the "Clear all areas" button.</p>
12	Start automatic echo suppression	Automatic echo suppression is a quick and simple, one-click option to suppress all previously sampled echoes. You must first take a sample of the echoes in the sensor's installed state and then press the "Start automatic echo suppression" button. The recorded echoes are then suppressed by setting the individual suppression areas based on algorithms.
13	Echo suppression activated/not activated	The "Echo suppression activated/not activated" parameter switches echo suppression in the sensor on or off and shows or hides the echo suppression display in the menu.

Table 7.1

Details about sampled echoes

Using an echo sample with manual echo suppression as an example, the following sets out the graphic elements of information in the display area.

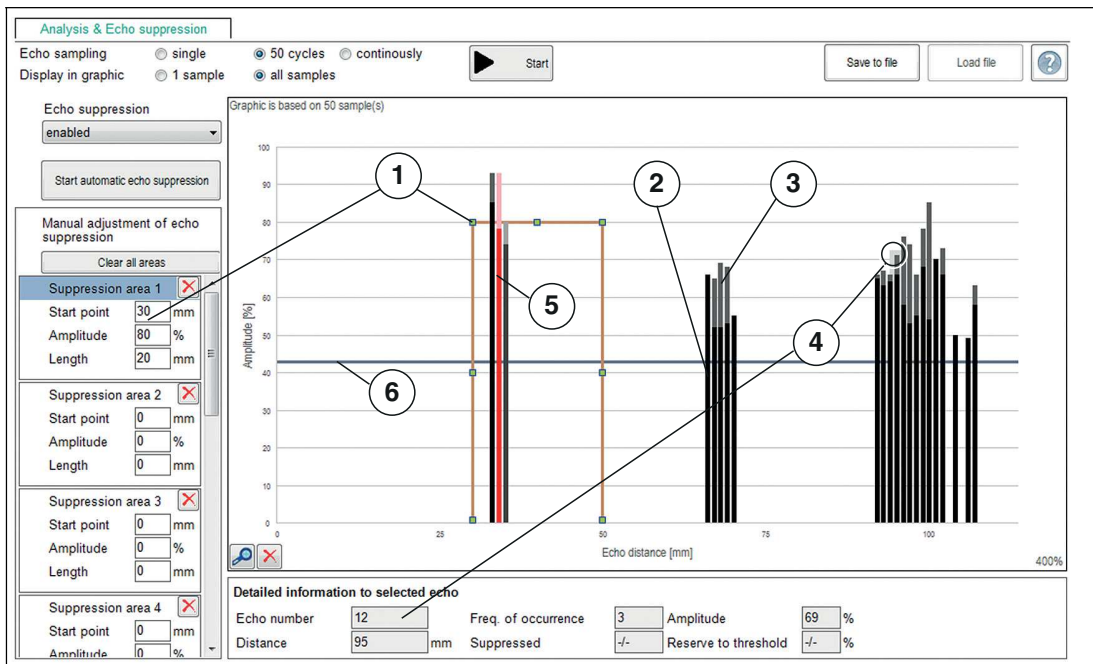

Figure 7.11

No.	Name	Description
1	Suppression area	A rectangle indicates the specified suppression area.
2	Black part of the column	If multiple echo samples are shown in the graphic, the black part of each column shows the amplitude which each of the recorded echoes reached from this distance.
3	Gray part of the column	The gray part of the column, above the black part, shows the variance in the strength of amplitude of all echoes from this distance.

No.	Name	Description
4	Details of the selected echo	<p>Clicking on a column from the echo sample displays the following detailed information in the "Details of the selected echo" area:</p> <ul style="list-style-type: none"> ■ Echo number: The echo number is a consecutive number which numbers the echoes shown in the graphic from left to right. ■ Frequency of occurrence: The value of the frequency of occurrence indicates how often the selected echo occurs in the currently displayed number of echo samples. ■ Amplitude: The strength of the amplitudes of the selected echo is displayed as a % value ■ Distance: The distance indicates the distance corresponding to the displayed echo value, measured from the sensor surface in mm. <p>Note: The displayed distance value always refers to the runtime measured by the sensor after the relevant echo was taken. This does not mean that an object has to be physically present in each of these distances. For example, if an object is located close to the sensor, so-called multiple echoes may occur. This involves reflecting the sound pulse of a measurement back and forth several times between the sensor and the object. The sensor sees each fresh echo reflected from the object as its own echo and provides it accordingly. These multiple echoes can be identified in the graphic as echoes in the x-times actual object distance.</p> ■ Suppressed: When indicating suppression (yes/no), the displays shows whether the selected echo exceeds or falls below the switching threshold. If the echo amplitude exceeds the switching threshold, the echo is "not suppressed," but can be evaluated by the sensor. If the echo amplitude is lower than the switching threshold, the echo is "suppressed." ■ Reserve to threshold: The threshold reserve value indicates how reliably an echo is detected or suppressed. This value is shaded by traffic light colors so that evaluation can be carried out easily.
5	Red column	<p>The evaluated echo of the last recorded echo samples is displayed in the graphic as a red column. This specific representation makes it possible to subsequently verify the effectiveness of set suppression areas because the evaluated echo can be easily distinguished from the rest.</p>
6	Sensor switching threshold (blue line)	<p>In the graphic, a "blue line" indicates the switching threshold of the sensor alongside the recorded echoes. Echoes for which amplitude exceeds this threshold can be evaluated by the sensor. Echoes below the switching threshold are in effect suppressed and will be discounted.</p>

Table 7.2

Application Information for Echo Suppression

In order to be able to suppress echoes, you first have to set the "Echo suppression" parameter to "enabled," provided that the parameter is not already set accordingly in the connected sensor. The "Start automatic echo suppression" button as well as the parameter values of the available suppression areas 1–10 are then displayed in the DTM.

Ideally, echo suppression areas should be based on a variety of echo samples (at least 50) because the echo amplitude can vary from measurement to measurement depending on the ambient conditions.

Obtaining sampled echoes from the original sensor mounting location in the plant is mandatory before starting targeted echo suppression.

Automatic Echo Suppression

If the echo from the target object is also contained in the echo samples, this will be suppressed through automatic echo suppression. This may occur, for example, when echo samples are taken in a partially-filled tank because then the echo from the surface of the liquid is also included in the echo samples.

The same applies in the case where samples are carried out in an empty tank because the echo from the base of the tank in most cases should still be identified as "Tank empty," even after echo suppression.

In these cases, a manual correction must be carried out to the corresponding suppression area to eliminate the relevant echo from the suppression (see section on "Manual echo suppression").

A lot of "Echo blocks" in the echo samples may lead to the 10 available suppression areas not being sufficient for algorithm-based automatic suppression to really suppress all recorded echoes. In this case, it is necessary to carry out manual adjustments to the individual suppression areas (see section on "Manual echo suppression").

Manual Echo Suppression

Each of the 10 suppression areas is specified via the "Start point," "Amplitude," and "Length" parameters (see section on "Menu description"). Each area can be modified or deleted individually or all at once.

To reliably suppress echoes under varying ambient conditions (for example fluctuations of air temperature or air humidity), we recommend selecting a suppression area which is larger than the echo or echo block to be suppressed. Specifically, this means that the amplitude value of the suppression area should be set at least 10 % higher than the largest echo amplitude to be suppressed. However, the amplitude value should not be set so high that the echo to detect (e.g., a fill level) is no longer recognized. For indoor applications, the lateral boundaries of the suppression area should be set to +/- 5 % and for outdoor applications to +/- 10% of the relevant echo distances, which should be suppressed with the area.

Example

In terms of the following echo sample, the echo labeled with the red arrow should be suppressed. The echo labeled with the green arrow comes from the object that is to be detected (e.g., the level surface).

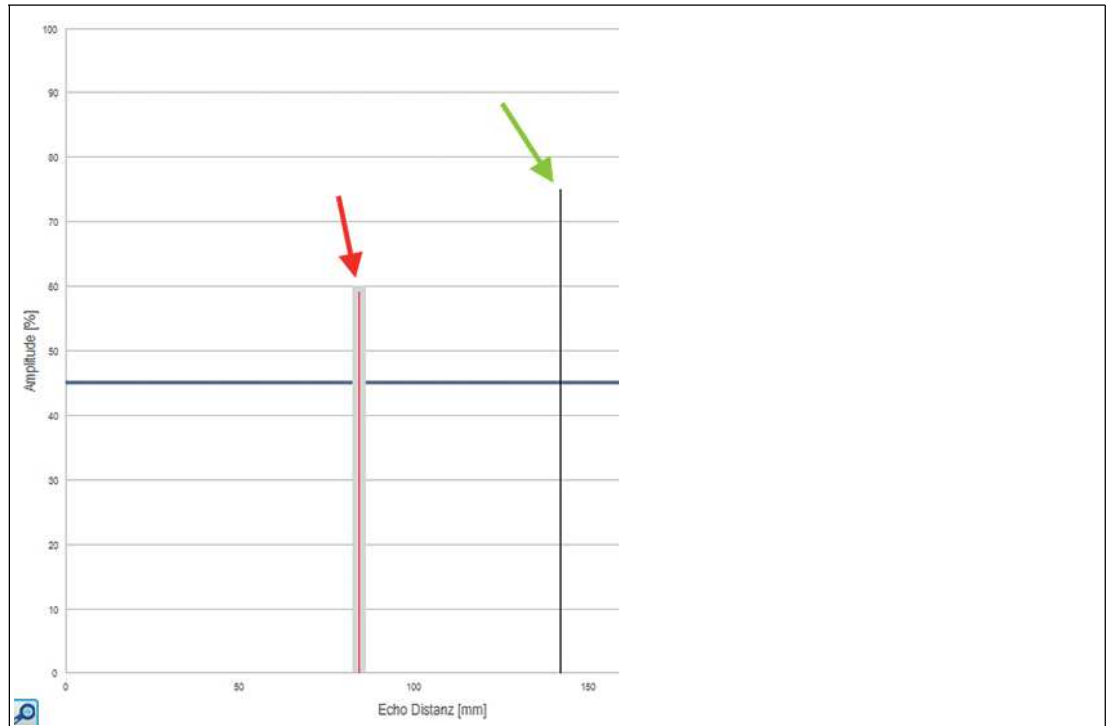

Figure 7.12

The echo to be suppressed has an amplitude of 59 % at a distance of 84 mm. To suppress the echo correctly and with reserve, for an indoor application the parameters for the suppression area should be set as follows (in brackets are the corresponding values for an outdoor environment):

- Start point: 80 mm (75 mm)
- Amplitude: 69 % (69 %)
- Length: 8 mm (18 mm)

The graphic with set suppression area for an interior application is as follows:

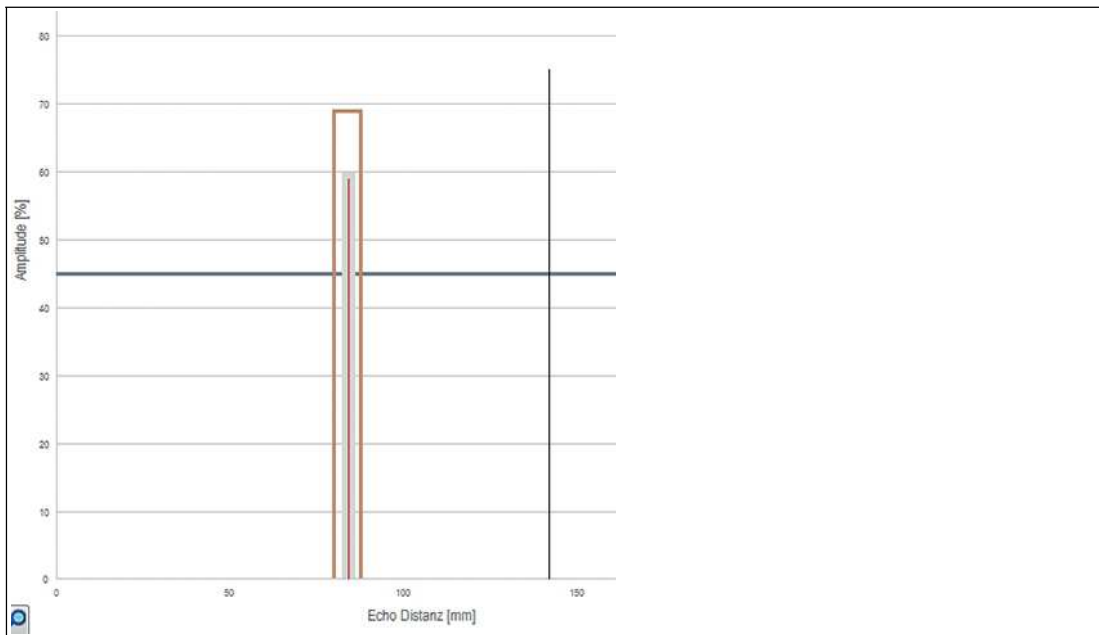

Figure 7.13



Note!

The boundaries of suppression areas can also be adjusted directly within the graphic by left-clicking and dragging with the mouse.



Note!

The amplitude difference between unwanted echoes and echoes from the desired target is critical to proper echo suppression performance.

With echoes from target objects which reflect well, unwanted echoes in the peripheral areas can be suppressed very successfully without impairing function because the echo amplitudes of the unwanted echoes are not too high in this case.

On the other hand, unwanted echoes in the center of the sound beam usually create an echo which is situated in approximately the same amplitude range as the echo of the object to be detected. For this reason it is not usually possible to suppress unwanted echoes with normal reflective properties in the center of the sound beam.

7.6 Observation Menu Option

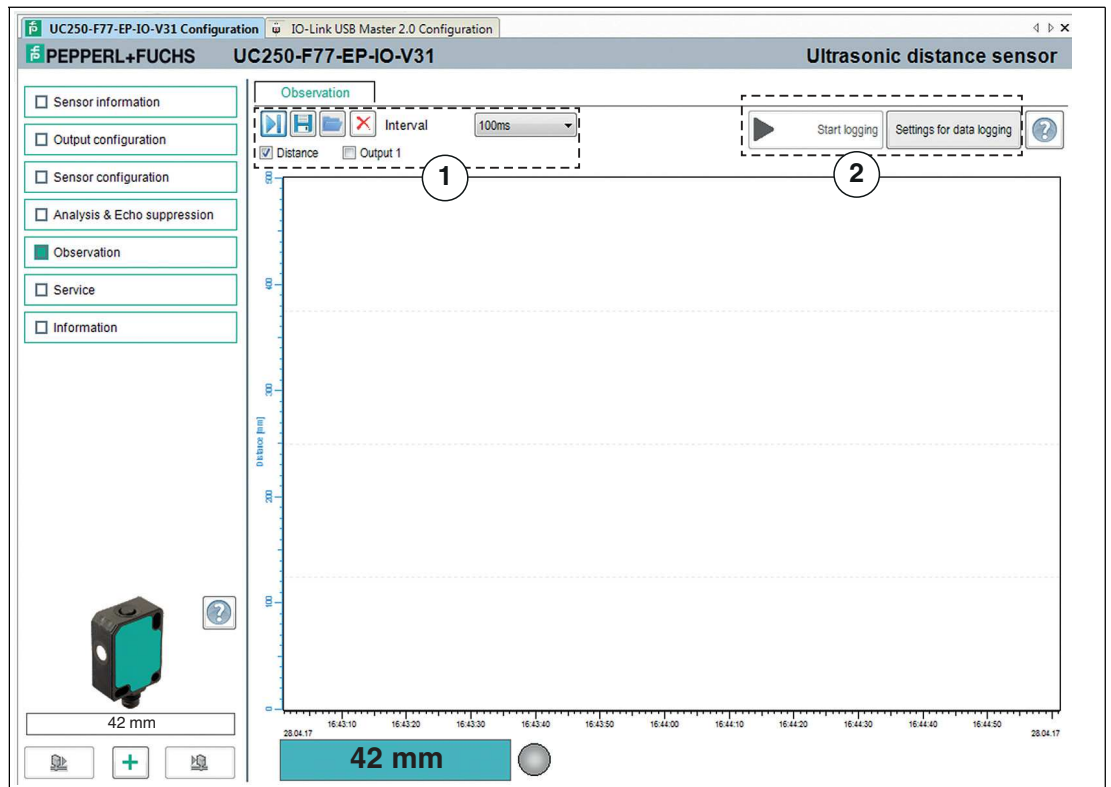

Figure 7.14

You can use the **Observation** menu option to track and record data from the ultrasonic sensor over time, as well as the corresponding behavior of the switching and analog outputs. You can choose from the "Visual observation" (1) or "Event-driven data logging" (2) application focuses.

Visual Observation

The visual observation functions (1) allow you during commissioning for example to observe whether data and switching characteristics of the sensor behave as intended.

When you first access the **Observation** menu option in the DTM, automatic recording of data will start in the graphic. From this point in time, recording will run continuously in the background. The data display works according to the "follow-mode-principle." It will always track the current measurement value in accordance with the rescale settings in the x-axis and make sure it is visible in the display. You can save the data displayed in this trend graphic in a file in various file formats for evaluation at a later stage.

Placing the check mark in front of the available measured variables or output statuses selects which data will appear in the graphic.

Event-Driven Data Logging

Event-driven data logging functions (2) allow you, for cause analysis for example, to monitor sensor logic in such a way that an event occurring sporadically is recorded in a file. You can specify the recording conditions from predefined trigger criteria such as changing the status of the switching output or a change to the value of the distance measurement. The DTM function then observes the sensor and writes the measured variables and output statuses to a file if an event occurs.



Note!

If the DTM is closed whilst data is being recorded, recording automatically stops. Values recorded up to this point in time are and will remain in the corresponding file.

Menu Description

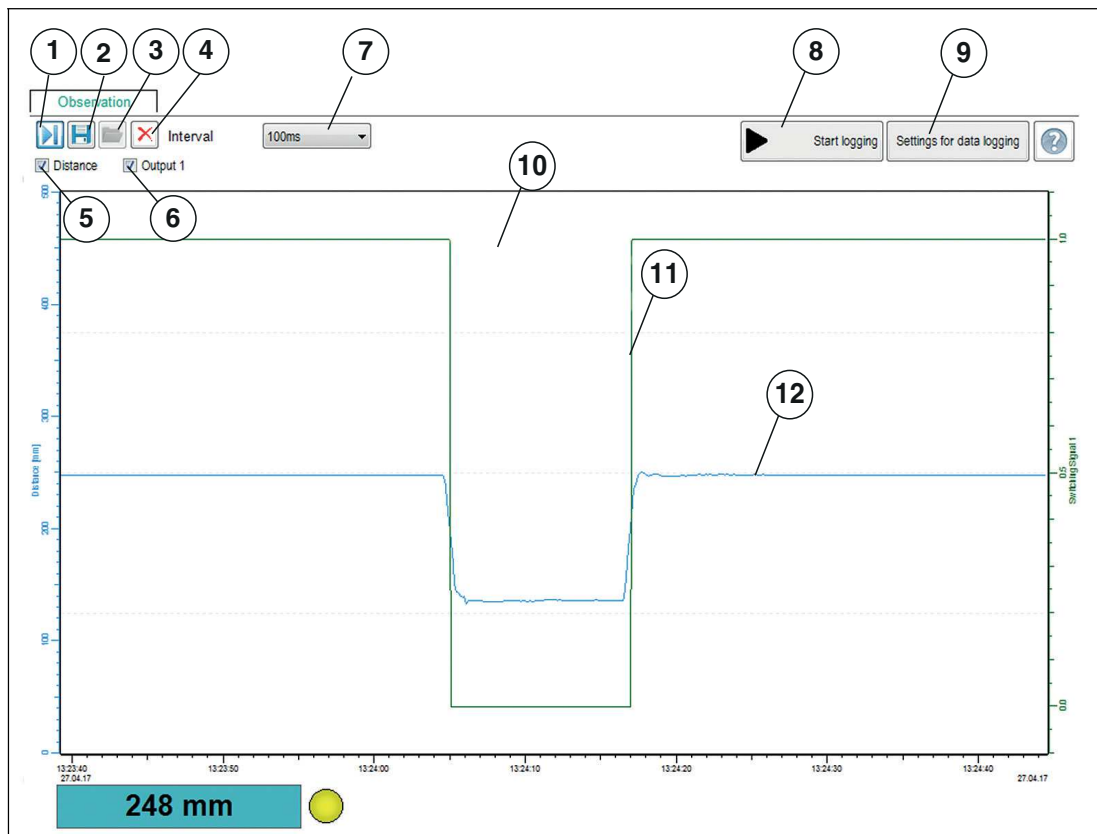

Figure 7.15

No.	Name	Description
1	Follow mode on/off	If follow mode is "On," data is displayed in accordance with the current rescale setting of the x-axis. The measured value is visible in the display. If follow mode is "Off," the data stops being continuously displayed. When follow mode is re-started, data recorded in the background is added in the meantime.
2	Save trend data	Only for visual observation You can save data recorded via follow mode in one of three available file formats (.csv, .xml, or .txt) by pressing the "Save trend data" button. In addition to this data, sensor settings (parameter values) will also be saved. This means it is possible to evaluate recorded data later "offline."
3	Load data	You can load the saved trend data (visual observation) or logging data (event-driven data logging) to the DTM again by pressing the "Load data" button to assess or evaluate the data. Files with recorded data combined with the parameter settings can be very useful for discussing issues with our experts. Note: You can only load a saved file if disconnected from the sensor.
4	Clear	Pressing the "Clear" button allows you to delete all data in the display area (10). All data recorded up to this point is discarded and the display is cleared. Recording automatically restarts from scratch.
5	Distance	By clicking on the check box, you can enable or disable display of the distance values in the display area in the form of a blue line.

2017-06

No.	Name	Description
6	Output	By clicking on the check box, you can enable or disable display of the output status (0/1) in the display area in the form of a green line. The analog output value is displayed in the diagram for an analog output.
7	Interval	You can use the "Interval" selection function to specify the time interval at which data is recorded in the graphic. There are several fixed intervals available between 100 ms and 1 hour.
8	Start recording	Only for event-driven data logging You can use the "Start recording" button to start and end event-driven recording of data in a file (data logging).
9	Settings for recording data	Only for event-driven data logging You can use the "Settings for data logging" button to specify events for data recording and the name of the log file via a menu.
10	Display area	In the display area, the "Distance" and "Output" check boxes can be used to display selected measured variables and output statuses in the form of line diagrams.
11	Output behavior (green line)	The green line indicates the logical status of the output (right y-axis) for the switch point set in the Output configuration menu option. The analog output value is displayed (likewise right y-axis) for a sensor with analog output.
12	Distance value line (blue line)	The blue line shows the distance value measured from the sensor (left y-axis).

Table 7.3

Scaling the x-axis and navigate to significant data

You can use the left and right mouse button to rescale the displayed area of the x-axis or move the display to focus on the required data.

To do so, you will need to move the cursor over the x-axis until the cursor becomes a hand icon. Then hold down the required mouse button and move the hand icon left or right along the x-axis.

- Both mouse buttons: moves the display area to the left or right.
- Right mouse button: rescales the x-axis from the right, thus retaining left time value.
- Left mouse button: rescales the x-axis from the left, thus retaining right time value.

Data logging setting

Pressing the "Settings for data logging" button opens the menu displayed below.

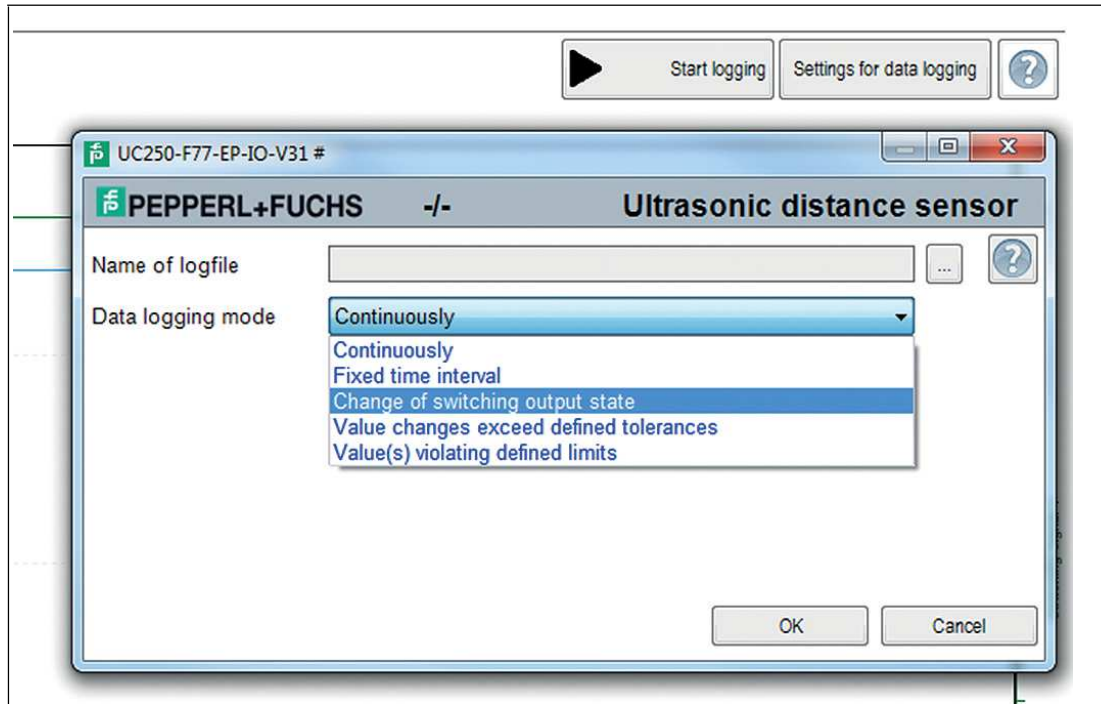

Figure 7.16

You can use the "Name of log file" field to set the file path and file names for logging data.

You can select "Data logging mode" to set the events that trigger automatic data recording. You need to press the OK button at the end to save the setting.

Measured data can be recorded either on a continuous or event-driven basis. For event-driven recording, the number of measured values to be recorded before and after the event is independently defined via two parameters.

The following recording modes are available:

- Continuous

Data is continuously recorded and saved in the file. Data is sequentially recorded, but is not necessarily consistent. Individual data may not be recorded depending on the sensor's repeat measurement rate, data transmission rate, computer's capacity, and operating system tasks.
- Fixed time interval

Data is recorded at fixed time intervals. The time interval can be selected in fixed increments between 500 ms and 2 hours.
- Change of switching output state

Data is recorded in the event of a change of status of a sensor switching output. A further parameter is used to define with what type of status change data should be recorded. You can choose status changes to "Closed," "Open," or "In both directions". If the sensor has more than one switching output, but only one should be used as a trigger for recording data, the other parameters need to be set to "Ignore."

- Value changes exceed defined tolerances

Data recording is triggered by changes to data which exceed the specified tolerance limits. The reference value is the distance value determined during the previous measurement. The permissible tolerances can be specified either as an absolute value, i.e., in mm, or as a percentage, relative to the previous measurement. If this tolerance limit is exceeded from one measurement to the next, data recording is triggered.

- Value violating defined limits

Data is recorded if specified, absolute limit values are exceeded. The distance value in mm as well as the value at the sensor analog output (if physically present on the sensor) are available as reference values. In addition, the "Log occurrence" parameter can be used to determine whether data recording should take place once per limit being exceeded or for the full duration.



1. Use the "Name of log file" field to set the file path and file name for logging data. To do so, click on the "..." button.
2. Use the "Data logging mode" option to set the events which should trigger automatic recording of data. You need to press the "OK" button at the end to save the setting.

7.7 Service Menu Option

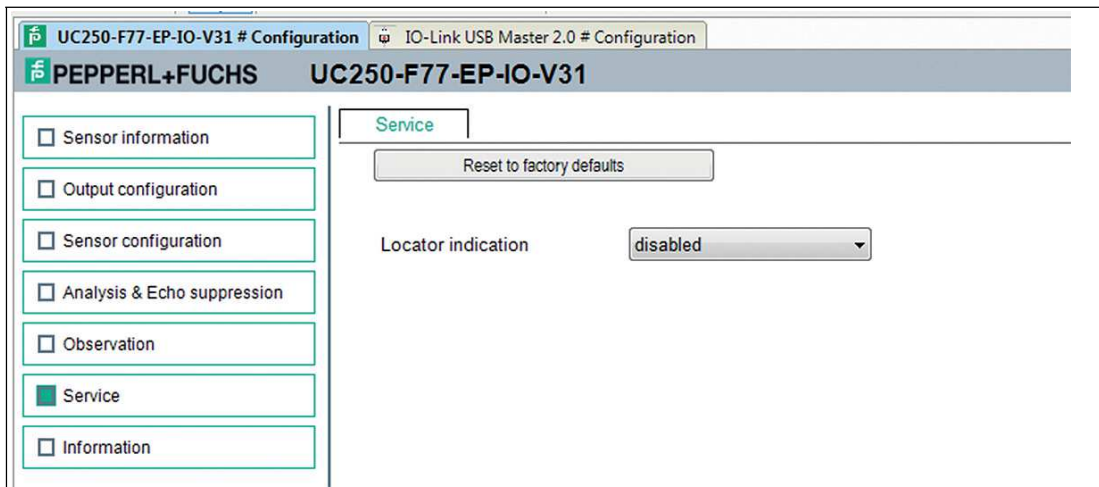

Figure 7.17

You can use the **Service** menu option to set the following service functions.

- **Reset to factory defaults:** activating the switch resets the sensor to settings as delivered. All previous parameter changes are lost as a result of this.
- **Locator indication:** setting the "localization display" to "enabled" makes the LEDs flash simultaneously. This function can be used to localize a sensor in a plant or machine more easily. This function is disabled by default, which means that the LEDs indicate status and diagnostic information.

7.8 Information Menu Option

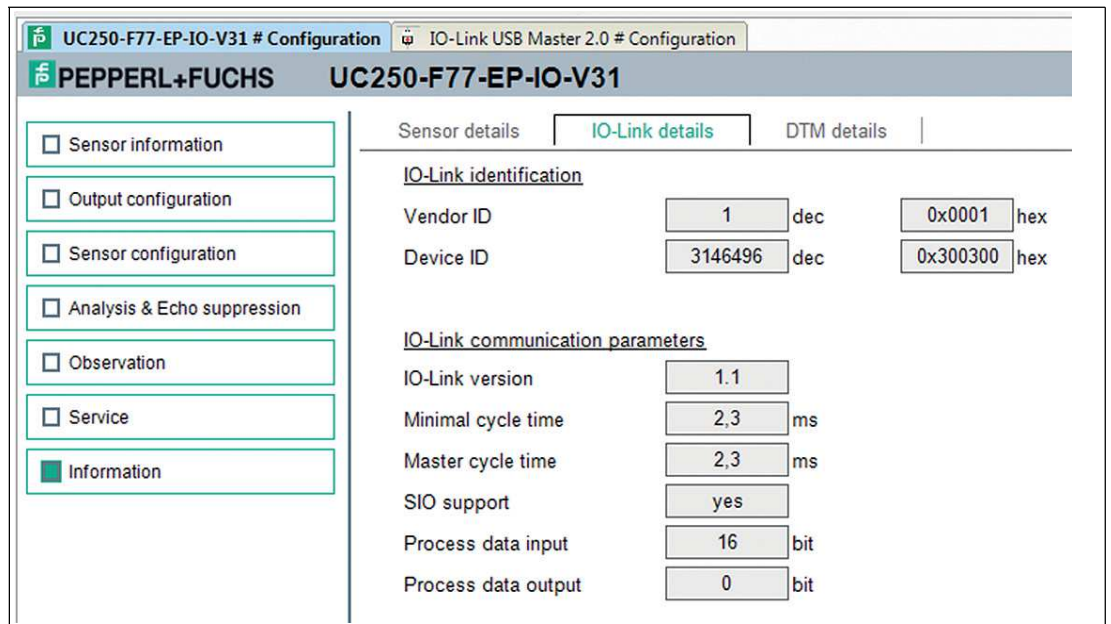

Figure 7.18

The **Information** menu option consists of 3 tabs

- **Sensor Details:** information about hardware and software version
- **IO-Link Details:** information about the device ID, vendor ID and information about the IO-Link communication parameters
- **DTM Details:** Information about the DTM version

8 Description of Sensor Parameters

8.1 Sensor Information

Application-specific tag

Parameter name	Access	Value range
Application-specific tag	Read/write	32 alphanumeric characters

Table 8.1

The user can use this parameter to tag the sensor, e.g., "Tank 2 fill level" or to tag the sensor in the plant design.

User tag

Parameter name	Access	Value range
User tag	Read/write	32 alphanumeric characters

Table 8.2

The user can use this parameter to tag the sensor, e.g., name of the customer's company, in whose plant the sensor is installed.

Operating hours

The parameter indicates the number of hours that the sensor has already been in operation for, i.e., has been supplied with voltage.

8.2 Output – Switching Output

8.2.1 Output Mode

Overview of output mode

Parameter name	Access	Value range
Output mode	Read/write	<ul style="list-style-type: none"> ■ Switch point mode ■ Window mode ■ Hysteresis mode ■ Retroreflective mode

Depending on the purpose of the sensor and its associated task, you can use this parameter to individually adjust the mode for each switching output.

There are four options to choose from:

- Switch point mode
- Window mode
- Hysteresis mode
- Retroreflective mode

Switch point mode

If the mode is set to "Switch point mode," the output status changes at the set switch point 1. The direction of motion or fill level of the object, to or from the sensor, as well as any configured switch point 2 are not relevant.

Switch Point Mode in Practice

In practice, this mode is used to monitor a tank fill level at a minimum or maximum level. If the media drops below or exceeds this level, the status of the switching output changes and indicates as such.

This setting is also suitable for preventing driverless transport systems from colliding with objects in the path of travel. In this application, the output changes value if an object is detected within a minimum distance. This causes the engine to stop or activates the vehicle's brakes.

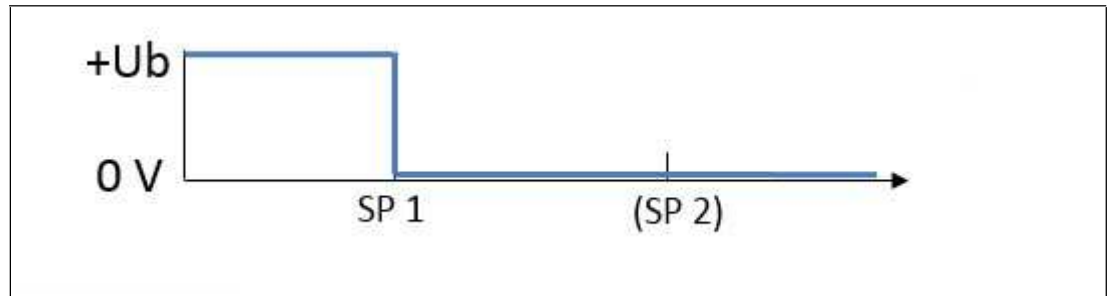

Figure 8.1 Example of behavior of a "normally-open" push-pull/PNP switching output in switch point mode

Window mode

When set to window mode, the status of the switching output changes if an object is detected within the area between switch points 1 and 2. The direction of motion of the object to and from the sensor is not relevant.

Window Mode in Practice

An ultrasonic sensor is mounted laterally on a conveyor belt and counts the conveyed goods. When window mode is set, its output only switches if objects are detected on the conveyor belt. Individuals who pass the sensor behind the conveyor belt do not cause the output to switch.

This setting can indicate whether a tank fill level is within a desired range and is neither too full or too empty.

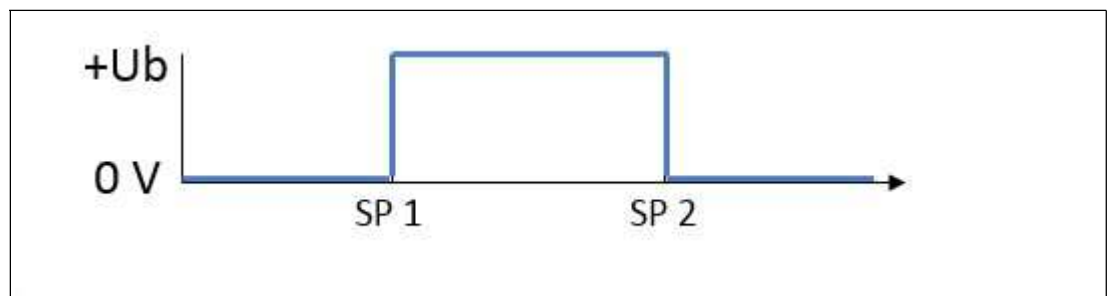

Figure 8.2 Example of behavior of a "normally-open" push-pull/PNP switching output in window mode

Hysteresis mode

In "Hysteresis mode" output mode, the status of the switching output changes if an object is approaching switch point 1. The status will change back to the previous value when the object passes switch point 2.

Hysteresis Mode in Practice

A so-called two-point control can typically be implemented in practice. For example, to directly control a pump which should always be filling a tank up to a specific level (>> switch point 1). Only when a minimum fill level (>> switch point 2) is not reached is filling restarted.

This function also allows the opposite situation to be achieved directly from the sensor. This means that in this case, the pump empties the liquid in a tank to a specified minimum level when it has reached maximum fill level. The emptying process should only be restarted if the maximum level is reached again.

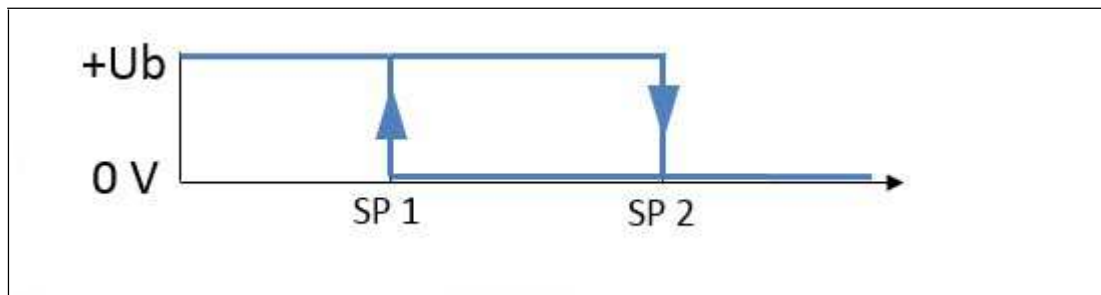

Figure 8.3 Example of behavior of a "normally-open" push-pull/PNP switching output in hysteresis mode

Retroreflective mode

In retroreflective mode, the ultrasonic sensor works in a similar way to an optical retroreflective sensor. An ultrasonic sensor is programmed to recognize a reference object, e.g., the floor, a conveyor belt or a side panel on a conveyor belt.

The switching output status changes if an object is detected in a shorter distance to the sensor than the reference range set around the reflector.

When detecting an object at a greater distance than the reference range set around the reflector, the switching output changes status, like when an echo does not come back to the sensor. This can happen in practice if an object placed in front of the reflector reflects the sound away or absorbs the ultrasound due to its material composition.

Only switch point 1 is relevant in this output mode; any configured switch point 2 has no effect.

Retroreflective Mode in Practice

An example of how this output mode is applied in practice is to detect vehicles in parking spaces. This involves ultrasonic sensors being mounted on the ceiling above the parking space, using the car park floor as a reference reflector. This means vehicles in a parking space can be reliably detected, even if its windshield is located below the sensor via which sound is reflected away.

Retroreflective mode can also be used to detect objects on a conveyor belt. This involves the sensor being mounted either alongside or above the conveyor belt, using the opposite side panel or the conveyor belt itself as a reference reflector. The sensor reliably detects any objects which pass it on the conveyor belt. This also happens even if the objects reflect sound away due to an inclined surface or absorb the sound as a result of material composition (e.g., foam components).

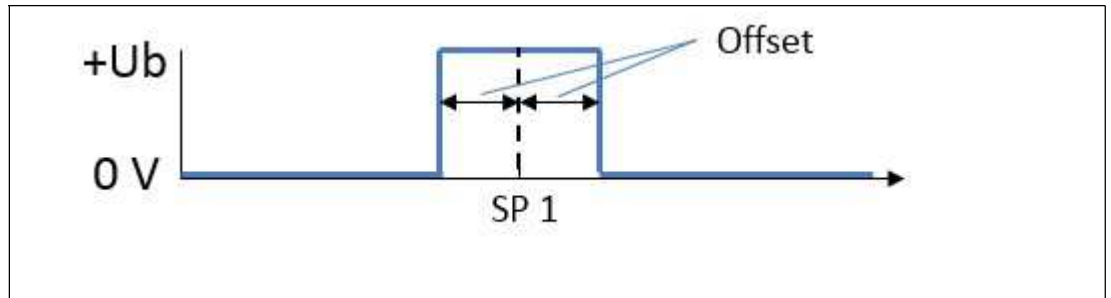

Figure 8.4 Example of behavior of a "normally-open" push-pull/PNP switching output in retroreflective mode

8.2.2 Output Logic

Parameter name	Access	Value range
Output logic	Read/write	<ul style="list-style-type: none"> ■ Normally-open ■ Normally-closed

Table 8.3

You can use this parameter to set the logic of the switching output.

8.2.3 Output Type

Parameter name	Access	Value range
Output type	Read/write	<ul style="list-style-type: none"> ■ Push-pull ■ Sourcing (PNP) ■ Sinking (NPN)

Table 8.4

You can physically operate the switching output of the sensor either as a push-pull, PNP, or NPN output and you can use this parameter to adjust the output.



Note!

If the second switching output or both switching outputs for a sensor do not physically exist, then the corresponding parameter may still be provided and adjusted via the IODD. However, this parameter has no physical effect in this scenario.

8.2.4 Switch Point 1

Parameter name	Access	Value range
Switch point 1	Read/write	<Beginning of adjustment range> ... <End of adjustment range> [mm] (See technical data in the sensor datasheet)

Table 8.5

You can use this parameter to adjust the switch point 1 in "mm", measured from the ultrasonic transducer surface of the sensor.

If switch point 1 is set to a farther distance than switch point 2, the two switch points are virtually inverted within the sensor. This is done to ensure that the set output mode is working as intended.



Note!

The DTM also accepts values between <Beginning of sensing range> and <Beginning of adjustment range> as well as values above <End of adjustment range> up to a certain limit. Values in these ranges are outside of the adjustment range specified by Pepperl+Fuchs; use them at your own risk.

8.2.5 Switch Point 2



Note!

Switch point 2 is not relevant for "Switch point mode" and "Retroreflective mode" output modes and is therefore hidden in the DTM.

Parameter name	Access	Value range
Switch point 2	Read/write	<Beginning of adjustment range> ... <End of adjustment range> [mm] (See technical data in the sensor datasheet)

Table 8.6

You can use this parameter to adjust the switch point 2 in "mm", measured from the ultrasonic transducer surface of the sensor.

If switch point 1 is set to a farther distance than switch point 2, the two switch points are virtually inverted within the sensor. This is done to ensure that the set output mode is working as intended.



Note!

The DTM also accepts values between <Beginning of sensing range> and <Beginning of adjustment range> as well as values above <End of adjustment range> up to a certain limit. Values in these ranges are outside of the adjustment range specified by Pepperl+Fuchs; use them at your own risk.

8.2.6 Retroreflective Mode Offset



Note!

The "Retroreflective mode offset" parameter is only relevant and visible in the DTM if the output mode is set to "Retroreflective mode."

Parameter name	Access	Value range
Retroreflective offset	Read/write	1 ... (0.5 x <end of adjustment range>) [mm] (See technical data in the sensor datasheet)

Table 8.7

You can use the "Retroreflective mode offset" parameter to change the size of the switching window in order to adjust the reflector distance defined by switch point 1. The specified offset works equally in both directions around the reflector distance, i.e., both in the direction of the sensor as well as away from the sensor. The offset is necessary to avoid output fluctuations due to changing environmental conditions.

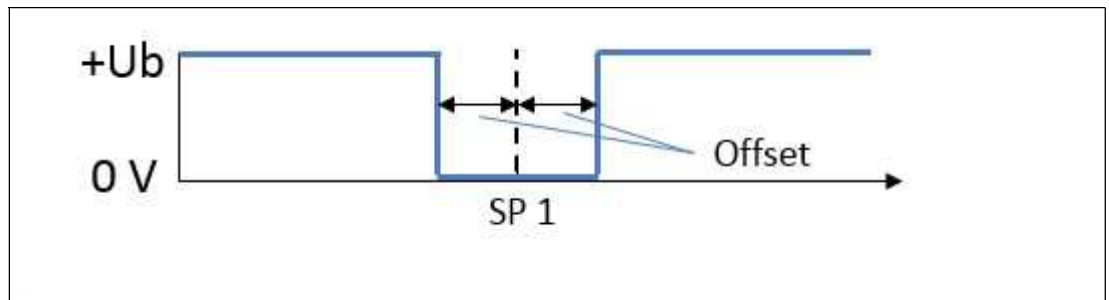

Figure 8.5 For example, retroreflective mode for push-pull/PNP switching output set to normally-closed



Note!

An offset value of at least 10 % of the reflector distance is typically recommended to prevent impact of temperature fluctuations, in outdoor applications too.

8.2.7 Switching Hysteresis



Note!

The "Switching hysteresis" parameter is not relevant if output mode is set to "Hysteresis mode" and is hidden in the DTM.

Parameter name	Access	Value range
Switching hysteresis	Read/write	<ul style="list-style-type: none"> ■ Low ■ Medium ■ High

Table 8.8

You can use this parameter to set the hysteresis for switch points 1 and 2. You can choose between three settings (low, medium, high). "Low" corresponds to a hysteresis of 1 % of the measured distance value, "medium" to 2 % and "high" to 5 %. In any case, the hysteresis is always at least 1 mm in size.

8.2.8 Switch-On Delay



Note!

This parameter influences the response time of the sensor.

Parameter name	Access	Value range
Switch-on delay	Read/write	0 ... 60000 [ms]

Table 8.9

You can use the "Switch-on delay" parameter to delay the switching output being switched on in order to stabilize the output signal and suppress short switching pulses resulting from potential interference.

The "output logic" parameter determines which signal change is considered as a "switch-on process."

If the output logic is set to "normally-open," the switch-on delay effects the change of output state from "Open" to "Closed."

If the output logic is set to "normally-closed," the switch-on delay effects the change of output state from "Closed" to "Open."

8.2.9 Switch-Off Delay



Note!

This parameter influences the response time of the sensor.

Parameter name	Access	Value range
Switch-off delay	Read/write	0 ... 60000 [ms]

Table 8.10

You can use the "Switch-off delay" parameter to delay the switching output being switched off.

This delay can be helpful if very fast events need to be reliably reported by programmable logic controllers with slower cycle time. A switch-off delay can also be useful when needing to ensure a certain over-travel time for components in applications.

The "output logic" parameter determines which signal change is considered as a "switch-off process."

If the output logic is set to "normally-open," the switch-off delay effects the change of output state from "Closed" to "Open."

If the output logic is set to "normally-closed," the switch-off delay effects the change of output state from "Open" to "Closed."

8.3 Output Configuration – Analog Output

8.3.1 Output Mode

Parameter name	Access	Value range
Analog output – Output mode	Read/write	<ul style="list-style-type: none"> ■ Rising ramp ■ Falling ramp

Table 8.11

Depending on the intended purpose of the sensor and its associated task, you can use this parameter to adapt the mode to the analog output. With "Rising ramp," the analog output value increases with an increasing object distance; with "Falling ramp," the analog output value reduces with an increasing object distance.

In practice, the "Falling ramp" output mode is usually used to display fill levels in a tank because a large analog value also corresponds to a large quantity of liquid in the tank.

For other applications in which the distance to the sensor is relevant, the "Rising ramp" output mode is usually used because a larger analog value also corresponds to a greater distance from the sensor.

8.3.2 Output Type

Parameter name	Access	Value range
Analog output – Output type	Read/write	<ul style="list-style-type: none"> ■ Current ■ Voltage

Table 8.12

You can physically operate the analog output of the sensor either as current or voltage output and select this via this parameter.

8.3.3 Near Limit

Parameter name	Access	Value range
Analog output – Near limit	Read/write	<Beginning of adjustment range> ... <End of adjustment range> [mm] (See technical data in the sensor datasheet)

Table 8.13

You can use this parameter to adjust the near limit of the analog range in mm, measured from the ultrasonic transducer surface of the sensor.



Note!

The DTM also accepts values between <Beginning of sensing range> and <Beginning of adjustment range> as well as values above <End of adjustment range> up to a certain limit. Values in these ranges are outside of the adjustment range specified by Pepperl+Fuchs; use them at your own risk.

8.3.4 Far Limit

Parameter name	Access	Value range
Analog output – Far limit	Read/write	<Beginning of adjustment range> ... <End of adjustment range> [mm] (See technical data in the sensor datasheet)

Table 8.14

You can use this parameter to adjust the far limit of the analog range in mm, measured from the ultrasonic transducer surface of the sensor.



Note!

The DTM also accepts values between <Beginning of sensing range> and <Beginning of adjustment range> as well as values above <End of adjustment range> up to a certain limit. Values in these ranges are outside of the adjustment range specified by Pepperl+Fuchs; use them at your own risk.

8.3.5 Lower Output Value



Note!

The DTM will display just the appropriate lower output value depending on the set output type for the analog output (current or voltage).

Parameter name	Access	Value range
Lower output value – Current	Read/write	0 ... 20 [mA]
Lower output value – Voltage		0 ... 10 [V]

Table 8.15

You can use this parameter to set the lower physical output value of the analog output, e.g., 4 mA with a 4..20 mA current output.

8.3.6 Upper Output Value



Note!

The DTM will display just the appropriate upper output value depending on the set output type for the analog output (current or voltage).

Parameter name	Access	Value range
Upper output value – Current	Read/write	0 ... 20 [mA]
Upper output value – Voltage		0 ... 10 [V]

Table 8.16

You can use this parameter to set the upper physical output value of the analog output, e.g., 20 mA with a 4..20 mA current output.

8.4 Sensor Configuration – Evaluation

8.4.1 Sound Beam Width



Note!

The selected sound beam width is a sensor adjustment and acts on all outputs alike. It is not possible to assign an individual sound beam width to the individual outputs.

Overview of Sound Beam Width

Parameter name	Access	Value range
Beam width	Read/write	<ul style="list-style-type: none"> ■ Wide ■ Medium ■ Small

Table 8.17

You can use the "Beam width" parameter to select one of the 3 predefined sound beam widths.

It is sometimes necessary to adapt the sound beam width, for example if in the application objects can be detected in the boundary area of the sound beam, which can lead to incorrect data.



Note!

The 3 available sound beam widths are the same 3 which can also be selected via the programming button on the sensor.

The following detailed settings for the selected sound beam widths are only an option in the DTM advanced view.

Small beam width

Parameter name	Access	Value range
Small beam width	Read/write	10 ... 100 [% in increments of 10 %]

Table 8.18

This enables you to further adjust the width of this sound beam in a range of 10 ... 100 % according to the previous selection of the small beam width (via parameter or programming button).

Medium beam width

Parameter name	Access	Value range
Medium beam width	Read/write	10 ... 100 [% in increments of 10 %]

Table 8.19

This enables you to further adjust the width of this sound beam in a range of 10 ... 100 % according to the previous selection of the medium beam width (via parameter or programming button).

Wide beam width

Parameter name	Access	Value range
Wide beam width	Read/write	10 ... 100 [% in increments of 10%]

Table 8.20

This enables you to further adjust the width of this sound beam in a range of 10 ... 100 % according to the previous selection of the wide beam width (via parameter or programming button).

8.4.2

Echo Evaluation



Note!

This parameter is only visible in the DTM advanced view.

Parameter name	Access	Value range
Echo evaluation	Read/write	<ul style="list-style-type: none"> ■ First echo ■ Strongest echo

Table 8.21

This parameter allows you to specify whether the sensor uses the first or strongest echo for evaluation purposes.

The preferred setting in most applications is to evaluate the "first echo." This is because the first echo corresponds to the closest object to the sensor which is relevant to the response of the sensor.

More rarely, it can be advantageous to set echo evaluation to "strongest echo" if smaller interfering objects (e.g., welding seams) near to the sensor prevent the correct tank fill level from being captured. By setting echo evaluation to "strongest echo," the echo with the highest amplitude is used for evaluation purposes.

8.4.3 Evaluation Method



Note!

This parameter is visible in the DTM advanced view.

Parameter name	Access	Value range
Evaluation method	Read/write	<ul style="list-style-type: none"> ■ Average value ■ Low pass ■ None

Table 8.22

The "Evaluation method" parameter allows you to specify the extent to which values of previous measurements are included in the evaluation of the current measurement. The objective is to ensure a robust measurement even when confronted with short-term disturbances such as rain, compressed air, agitators, or wave formation on liquid surfaces.

Evaluation Methods in Practice

In most applications the **"Average value" setting** is proven to be effective. This involves calculating a floating arithmetic average value over the latest data in accordance with the setting of the "Averages & skip count" parameter.

When detecting a tank fill level where the liquid surface is heavily agitated, the **"Low pass" setting** can be of benefit. With this evaluation method, previous data is included when determining the current distance value according to the "Weighting of former measurement", "Allowed deviation to former measurement" and "Skip time" parameters. The evaluation produces a typical low pass behavior, i.e., the distance value output by the sensor follows the actual measured value and the sensor response time is delayed accordingly. In addition, large changes to the measured value are only taken into account if they occur repeatedly and/or after a certain period of time.

With the **"None" setting** each individual measured value is output directly at the output. This setting is not recommended for most applications as faulty measurements resulting from external influences immediately have an effect on the output. When using the evaluation method, filtering and/or validation of the data by downstream logic controllers (like a programmable logic controller (PLC)) is recommended.

8.4.4 Averages & Skip Count



Note!

This parameter is only relevant and visible in the DTM if the "Evaluation method" is set to "Average value."

Parameter name	Access	Value range
Averages & skip count	Read/write	<ul style="list-style-type: none"> ■ M=2, N=0 ■ M=3, N=0 ■ M=3, N=1 ■ M=4, N=0 ■ M=4, N=1 ■ M=5, N=0 ■ M=5, N=1 ■ M=5, N=2 ■ M=6, N=0 ■ M=6, N=1 ■ M=6, N=2 ■ M=7, N=0 ■ M=7, N=1 ■ M=7, N=2 ■ M=7, N=3 ■ M=8, N=0 ■ M=8, N=1 ■ M=8, N=2 ■ M=8, N=3

Table 8.23

You can use this parameter to control the depths of the average determination. M defines the total number of measurements which are used to generate average determination. N defines the number of measurements from the number of M which are not taken into account for average determination. These are the value/values with the greatest deviation from the measurement result most recently determined. The current measurement result is calculated arithmetically from the remaining data.

8.4.5 Weighting of Former Measurement



Note!

This parameter is only relevant and visible in the DTM if the "Evaluation method" parameter is set to "Low pass."

Parameter name	Access	Value range
Weighting of former measurement	Read/write	1 ... 99 [%]

Table 8.24

This parameter determines how much weighting in percentage terms the result of the previous measurement result is given in the current evaluation.

The following formula applies:

$$\text{Res}_N = (\text{Res}_{N-1} \times W + \text{Meas} \times (100 - W)) / 100$$

Res = result

W = "weighting of previous measurement" factor

Meas = current measured value

This means that the less the "Weighting of former measurement" value, the closer the sensor's output follows the real distance.

8.4.6 Allowed Deviation to the Former Measurement



Note!

This parameter is only relevant and visible in the DTM if the "Evaluation method" parameter is set to "Low pass."

Parameter name	Access	Value range
Allowed deviation to the former measurement	Read/write	10 ... 50 [%]

Table 8.25

Together with the "Skip time" parameter, you can use this parameter to define an acceptance filter to filter short disturbances, so that the measured result is not changed.

The "Allowed deviation to the former measurement" parameter defines the value by which the new measured value may deviate at most from the previous measurement result. Only measured values with allowed deviation will be included in the calculation of the new measurement results. If the deviation is exceeded, the measured values are ignored until the set skip time is reached (see "Skip time" parameter).

8.4.7 Skip Time



Note!

This parameter is only relevant and visible in the DTM if the "Evaluation method" parameter is set to "Low pass."

Parameter name	Access	Value range
Skip time	Read/write	0 ... 60000 [ms]

Table 8.26

Together with the "Allowed deviation to former measurement," this parameter lets you define an acceptance filter to filter short disturbances, so that the measured result is not changed.

The "Allowed deviation to former measurement" parameter defines the value by which the new measured value may deviate at most from the previous measurement result. Only measured values with allowed deviation will be included in the calculation of the new measurement results. If the deviation is exceeded, the measured values are ignored until the set skip time is reached.

8.4.8 Temperature Compensation



Note!

This parameter is visible in the DTM advanced view.

Parameter name	Access	Value range
Temperature compensation	Read/write	<ul style="list-style-type: none"> ■ Disabled ■ Enabled

Table 8.27

The speed of sound and subsequently an ultrasonic sensor's accuracy is affected by changes in ambient temperature. By using the "Temperature compensation" parameter, you can switch the sensor's integral automatic temperature compensation off and on.

When this parameter is enabled, the distance value is calculated taking into account the ambient temperature continuously measured by the sensor. This method automatically corrects measuring errors resulting from a changing ambient temperature and thus greatly improves the measuring accuracy of the sensor.

If disabled, the distance value is calculated on the basis of the temperature value provided by the "operating temperature" parameter.

Temperature Compensation in Practice

With active temperature compensation, ambient temperature is measured within the sensor housing. The accuracy of this temperature measurement can be falsely influenced by external influences which heat or cool the sensor housing. Such influences can be, for example:

- Solar radiation
- High load on the sensor output resulting in a great deal of heat within the sensor housing
- Cleaning the sensor with cold water

In applications with significant fluctuations in ambient temperature, e.g., as a result of heat produced by machines and/or processing, or outside, we generally recommend enabling temperature compensation

In applications with an almost constant temperature, e.g., in large tanks, it may be useful to disable automatic temperature compensation. This is useful because then other influences (see note) will not impact measurement accuracy.



Note!

Internal temperature compensation can be disabled if the ambient temperature of the ultrasonic sensor is measured on the process side. The measured value of the ultrasonic sensor can then be corrected in the downstream logic unit taking into account the measured ambient temperature.

8.4.9 Operating Temperature



Note!

This parameter is visible in the DTM advanced view.

Parameter name	Access	Value range
Operating temperature	Read/write	-40 ... 100 [°C]

Table 8.28

With disabled temperature compensation (see "Temperature compensation" parameter), the operating temperature specified here is used to calculate the object distance from the measured sound propagation time. You can specify a value within the allowable value range.

8.4.10 Foreground Suppression



Note!

This parameter is visible in the DTM advanced view.

Parameter name	Access	Value range
Foreground suppression	Read/write	<End of dead band> ... <End of adjustment range> [mm]

Table 8.29

You can use the "Foreground suppression" parameter to define an area in front of the sensor where all received echoes are ignored. The range extends from the transducer surface of the sensor up to the distance value specified by this parameter.

By default, the value is set to <End of dead band>.

8.4.11 Background Suppression



Note!

This parameter is only visible in the DTM advanced view.

Parameter name	Access	Value range
Background suppression	Read/write	<Beginning of sensing range> ... <End of sensing range> [mm]

Table 8.30

You can use the "Background suppression" parameter to specify a range in which incoming echoes are discounted. When doing so, the input value represents the start of this range and therefore represents the distance from which all incoming echoes are discounted.

8.4.12 Sensor Cycle Time



Note!

This parameter is only visible in the DTM advanced view.

Parameter name	Access	Value range
Sensor cycle time	Read/write	<min. cycle time> ... 60000 [ms]

Table 8.31

You can use the "Sensor cycle time" parameter to specify the length of a measuring cycle. The minimum allowable cycle time depends on the range of the respective sensor and is set at the factory. If a value exceeding the minimum cycle time is entered, the sensor pauses after its measurement for the rest of that time period before the next measurement starts.



Note!

The minimum cycle time is dependent on the detection range of the respective sensor. If values that are too small are entered in the DTM, a corresponding message will appear stating the minimum allowable value for the selected sensor.

8.4.13 Ultrasonic Pulse Length



Note!

This parameter is only visible in the DTM advanced view.

We recommend only changing this parameter after consulting our application specialists.

Parameter name	Access	Value range
Ultrasonic pulse length	Read/write	<ul style="list-style-type: none"> ■ Automatic ■ Short pulse ■ Long pulse

Table 8.32

You can use the "Ultrasonic pulse length" parameter to select the length of the transmission pulse. The factory default ultrasonic pulse length is set to automatic, which is also the correct setting for the large majority of the applications. In this case, the sensor itself automatically chooses the correct pulse length between the short and long pulse depending on the detected object distance.

Setting in exceptional cases

We recommend adjusting the short pulse only in exceptional cases, such as applications in which only laterally-moving objects need to be detected very quickly very close to the sensor. This achieves only a fraction of the nominal range because the short pulse does not provide for a large detection range.

It is helpful to adjust to the long pulse in applications in which only laterally-moving objects need to be detected very quickly at a medium to large distance to the sensor. The long pulse setting increases the dead band in comparison to the specified datasheet value.

Then the sensors will only use the selected pulse length for your measurements.

8.5 Sensor Configuration – Synchronization



Note!

In addition to setting the "Synchronization mode" parameter, further measures are necessary for synchronization to be successful. This could include connecting the devices to each other accordingly. The commissioning instructions for the respective sensor provide details on this.

Synchronization Mode

Parameter name	Access	Value range
Synchronization mode	Read/write	<ul style="list-style-type: none"> ■ Automatic multiplex mode ■ Automatic common mode ■ Externally controlled

Table 8.33

In applications where multiple ultrasonic sensors are operated in close proximity to each other, we must prevent these sensors from mutually influencing each other. Otherwise it can result in individual devices providing incorrect measurements. The easiest way to solve this problem is by synchronizing the devices.

You can set the type of synchronization by using the "Synchronization mode" parameter. The following are the various synchronization modes in detail.

Automatic Multiplex Mode

This type of synchronization is essential for all applications in which each sensor has to individually determine its distance from the object.

The synchronized sensors self-synchronize in succession, i.e., there is always just one sensor transmitting at any one time. The measuring cycles of the individual sensors run in succession in a chronological sequence.

Advantage: mutual interference is completely avoided.

Disadvantage: delayed response time of the sensors by factor n. (n = number of the synchronized sensors)

Automatic Common Mode

We recommend synchronizing in automatic common mode for all applications where there is range monitoring, which is carried out using several sensors mounted in parallel. For example, this could be a automatically-guided transport system which is implemented with several sensors mounted in parallel. With these applications, it just has to be ensured that the automatically-guided transport system does not collide with any obstacle. For the individual sensor, it is irrelevant which sensor the sound of the received echo has been sent from.

The synchronized sensors work in a self-synchronized way at the same time, i.e., all sensors always send their ultrasound pulse at the same time.

Advantage: response time of the individual sensors is as short as in stand-alone mode.

Disadvantage: mutual interference cannot be completely ruled out.

External Synchronization

External synchronization is only necessary if the number of sensors to be synchronized exceeds the maximum specified in the datasheet. Or if the sensors need to be triggered in a unique, application-specific sequence.

The synchronized sensors are triggered in parallel by an external square-wave signal (e.g., a PLC output) and all sensors always send their ultrasound pulse at the same time.

8.6 Sensor Configuration – Echo Loss and Error Handling

8.6.1 No Echo

Parameter name	Access	Value range
No echo	Read/write	<ul style="list-style-type: none"> ■ No error ■ Error

Table 8.34

You can use this parameter to confirm whether "Sensor receives no echo" should be classified as an error or not.

With the default "No error" setting, the sensor not receiving an echo will not be interpreted as an error. In this instance, the sensor is behaving in terms of its outputs as if an object is at a maximum distance.

In some applications, normal operation may mean that a sensor should never lose its echo. However by setting the parameter as "Error," sensor output can be rendered safe should an error occur. Output behavior in the event of an error is determined via the "Output behavior if an error occurs" parameter.

8.6.2 Output behavior if an error occurs

Parameter name	Access	Value range
Output behavior if an error occurs – Switching output	Read/write	<ul style="list-style-type: none"> ■ Freeze ■ Max. distance ■ Closed ■ Open
Output behavior if an error occurs – Analog output	Read/write	<ul style="list-style-type: none"> ■ Freeze ■ Max. distance ■ Replacement value

Table 8.35

You can use this parameter to adjust the behavior of the output in the event of an error.

Possible error cases are:

- Extremely loud ambient noise in the ultrasonic frequency range of the sensor
- Hardware error in the sensor electronics
- Sensor receives no echo (only an error case if "No echo" parameter is set as "Error")

The meaning of the individual parameter values is explained in the following table.

Parameter value	Meaning
Freeze	The output retains its last status or value until a new valid measured value can be determined by the sensor.
Max. distance	In the event of an error, the output behaves as it would when an object is at a maximum distance from the sensor.
Closed	This setting is only available for switching outputs. It sets the output status to "Closed" in the event of an error.

Parameter value	Meaning
Open	This setting is only available for switching outputs. It sets the output status to "Open" in the event of an error.
Replacement value	This setting is only available for analog outputs. It specifies that in the event of an error, a certain output value should be output at the analog output. In the event of an error, this output value is determined via the "Error replacement value – current" or "Error replacement value – voltage" parameter.

8.6.3 Error Replacement Value – Current/Voltage



Note!

To be able to adjust the replacement value, the "Replacement value" setting must be set to "Output behavior if an error occurs" for the analog output in the DTM. Only the error replacement value parameter appropriate to the analog output and the selected output type is displayed ("Error replacement value – current" or "Error replacement value – voltage").

Parameter name	Access	Value range
Error replacement value – current	Read/write	0 ... 200 [x 0.1 mA]
Error replacement value – voltage	Read/write	0 ... 200 [x 0.1 V]

Table 8.36

You can use this parameter to adjust which value the analog output should adopt in the event of an error. Adjustment is possible in increments of 0.1 mA or 0.1 V.

The final value actually output at the analog output in the event of an error (current/voltage value) depends on the setting of the "Output type" parameter for the analog output.

8.7 Sensor configuration – Local controls

8.7.1 Local controls

Parameter name	Access	Value range
Programming button	Read/write	<ul style="list-style-type: none"> ■ Locked ■ Time locked (5 min) ■ Unlocked

Table 8.37

You can use this parameter to set whether and in what period of time during operation of the sensor local controls can be used to carry out changes.

By default, local controls are locked 5 minutes after switching on the power supply or after the last access to the local controls (>> time locked (5 min)).

If the parameter is set to "Locked," the local controls are locked permanently.

By selecting "Unlocked," the local controls can be accessed at any time. You can always change the sensor settings via the local controls.

8.7.2 Local Controls Status

Parameter name	Access	Value range
Local controls status	Read only	<ul style="list-style-type: none"> ■ Button not pressed ■ Button pressed

Table 8.38

You can use this parameter to check that the programming button on the sensor is working properly.

If the programming button on the sensor is working properly, the parameter value changes when the programming button is pressed or released. If the parameter value does not change, there may be a fault with the programming button.

8.8 Service

8.8.1 Locator Indication

Parameter name	Access	Value range
Locator indication	Read/write	<ul style="list-style-type: none"> ■ Disabled ■ Enabled

Table 8.39

You can use this parameter to switch the locator indication on and off. When locator indication is activated, the yellow and green LEDs on the sensor flash at the same time with a specific flashing sequence. This function can be used to localize the sensor in a plant or machine more easily.

8.8.2 "Reset to Factory Defaults" Button

By pressing this button, you can restore the sensor to its factory settings. When doing so, a security prompt will initially appear.

9 Synchronizing Multiple Sensors

The sensor is fitted with a synchronization connector that suppresses mutual interference from external ultrasonic signals. The following 3 types of synchronization can be set:

- Automatic multiplex mode
- Automatic common mode
- External synchronization



Note!

If the synchronization option is not used, the synchronization connection must be connected to ground (0 V).

In the event that a sensor operated in a synchronized group is programmed using the programming button, the start of the programming process may be delayed. The remaining sensors in the synchronized group go into standby mode for the duration of the programming process and do not carry out any measurements.

Programming of a single sensor must not be carried out using the programming button in an externally synchronized sensor group. The remaining sensors in the group carry out further measurements using the external trigger. This influences the measurement of the sensor to be programmed

Automatic Multiplex Mode

Several sensors (see datasheet for the maximum number) can be synchronized by simply connecting the synchronization connectors on the sensors. In this case, the sensors self-synchronize in succession in multiplex mode.

Only one sensor sends signals at any one time. The measuring cycles of the individual sensors run in succession in a chronological sequence. This also increases the response time of the sensors in proportion to the number of sensors in the synchronization group.

Automatic Common Mode

Multiple sensors (see datasheet for the maximum number) can be synchronized by simply connecting the synchronization connectors on the sensors and setting the synchronization mode to "Automatic common mode" via the IO-Link interface. In this case, the sensors self-synchronize at the same time, i.e., all sensors always send their ultrasound pulse at the same time.

External Synchronization

Multiple sensors can be jointly controlled by an external square-wave signal, e.g., a PLC output. The maximum number depends on the driver capabilities of the external device to be used for synchronization. In this case, the sensors are triggered in parallel and operate synchronously, i.e., at the same time. All sensors must be configured via the IO-Link interface in the "External synchronization" synchronization mode.

The necessary minimum pulse duration must be observed (see datasheet). If a high level is present on the synchronization connection for longer than 1 second, the sensor goes into standby mode (green LED is flashing).

As long as a low level is present on the synchronization input, the sensor carries out measurements in accordance with the sensor cycle time. If a high level is present on the synchronization input for longer than 1 second, the sensor goes on standby (green LED is flashing). As long as the sensor is in standby mode, the last received output conditions are retained.



The synchronization connection of the sensors supplies an output current in the case of a low signal, and generates an input impedance in the case of a high signal. Please note that the device used for external synchronization must have the following driver capability:

- Driver current acc $+UB > n \times$ (high level/input impedance)
- Driver current acc $0V > n \times$ output current

(n = number of sensors to be synchronized)

10 Maintenance and Repair

10.1 Maintenance Work

The sensor itself is maintenance-free. For this reason, it is not necessary to carry out regular adjustments or maintenance work on the sensor itself.

However, check that the sensor and connector are tight within the scope of routine maintenance intervals. You may also want to check that the connection cable is installed and intact.

10.2 Cleaning

Cleaning is only necessary in applications in which the transducer surface is exposed to dirt or build-up.

In general, the following applies as far as cleaning is concerned:

- Only with water without chemicals
- Without pressure/high pressure
- Only by using a soft cloth
- No abrasive cleaning, scratching, or scrubbing

10.3 Resetting to the Factory Default

You can reset the sensor to the factory default setting in the following ways:

- Using the programming button
- Via the DTM in the **Service** menu
- Via IO-Link



Resetting with the programming button

1. Disconnect the sensor from the power supply.
2. Press and hold the T programming button.
3. Switch on the supply voltage. The yellow and red LEDs flash simultaneously for 5 seconds. Then the yellow and green LEDs flash simultaneously for a further 5 seconds.
4. Release the T programming button while the yellow and green LEDs flash simultaneously.

↳ The sensor will now function with the original factory settings. If the T programming button continues to be pressed down beyond this flash sequence, the sensor changes back to normal operation (green LED lights up). In this case, all settings remain unchanged in the sensor.

The following graphic illustrates the sequence for the reset to factory settings:

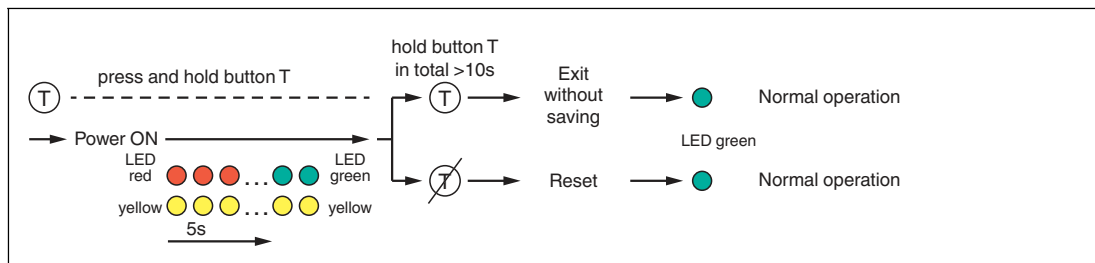

Figure 10.1

11 Troubleshooting

11.1 What to Do in Case of an Error

In case of an error, check whether a fault with the sensor can be remedied according to the following checklist.

If none of the information specified in the checklist solves the problem, in the event of queries contact Pepperl+Fuchs via your sales office. Have details of the model number and firmware version of the sensor ready if possible.

Checklist

Error	Cause	Remedy
Green LED not lit up	The power supply is switched off.	Check whether there is a reason why the power supply is switched off (installation or maintenance work, etc.). Switch on the power supply if appropriate.
Green LED not lit up	The plug is not connected to the connector on the sensor.	Connect the plug to the sensor and tighten the cap nut by hand.
Green LED not lit up	Wiring error in the splitter or switch cabinet.	Check the wiring carefully and repair any faults with the wiring.
Green LED not lit up	Supply cable to the sensor is damaged.	Replace the damaged cable.
No IO-Link connection to the device	The communication port on the sensor is not connected to the IO-Link master.	Make sure that the communication port on the sensor is connected to the IO-Link master.
No IO-Link connection to the device	No power supply	Check whether there is a reason for the absence of the power supply (installation or maintenance work, etc.). Switch on the power supply.
The target object is not detected, even though the sensor is OK	Perhaps there is an obstruction in the vicinity of the sensor	Check that the sensor is correctly aligned. Check sensor configuration and if necessary, change the sound beam width.

12 Appendix

12.1 IO-Link Device Parameters



Note!

The existing indexes for the various sensors differ according to their properties. For example, indexes for configuring an analog output are only available for sensors with an analog output.

Service commands

Name	Index (dec)	Sub-index	Type	Data type	Value	Default value	Unit
Reset to factory defaults	2		W	unit8	0x82		
Locator indication	127		R/W	unit8	0x00: disabled 0x01: enabled	0x00	

Process data input description

Name	Index (dec)	Sub-index	Type	Data type	Value	Default value	Unit
Process data	40		R	unit16	14-bit distance value + 2-bit BinaryDataChannel 1/2 Valid distance values in mm: UC250: 0 ... 425 UC400: 0 ... 680 UC800: 0 ... 1200 Replacement values: 16379: hardware error 16380: ambient noise error 16383: no-echo		

Identification parameters

Name	Index (dec)	Sub-index	Type	Data type	Value	Default value	Unit
Vendor name	16		R	char[32]	Pepperl+Fuchs	Pepperl+Fuchs	
Vendor text	17		R	char[32]			
Device name	18		R	char[32]			
Part number	19		R	char[16]			
Device family	20		R	char[32]	Ultrasonic distance sensor	Ultrasonic distance sensor	
Serial number	21		R	char[16]			
Hardware revision	22		R	char[7]			
Firmware revision	23		R	char[7]			
Application specific tag	24		R/W	char[32]			

2017-06

Name	Index (dec)	Sub-index	Type	Data type	Value	Default value	Unit
User tag	192		R/W	char[32]			
Operating hours	224		R	unit32			0.25h

Device parameters

Name	Index (dec)	Sub-index	Type	Data type	Value	Default value	Unit
Output Configuration							
Switching output – Switch point 1	60	1	R/W	unit16	UC250: 20 ... 425 UC400: 30 ... 680 UC800: 60 ... 1200	UC250: 20 UC400: 30 UC800: 60	mm
Switching output – Switch point 2	60	2	R/W	unit16	UC250: 20 ... 425 UC400: 30 ... 680 UC800: 60 ... 1200	UC250: 20 UC400: 30 UC800: 60	mm
Switching output – Output logic	61	1	R/W	unit8	0x00: Normally open 0x01: Normally closed	0x00	
Switching output – Output mode	61	2	R/W	unit8	0x01: Switch point mode 0x02: Window mode 0x03: Hysteresis mode 0x80: Retroreflective mode	0x02	
Switching output – Switching hysteresis	61	3	R/W	unit16	0x00: low 0x01: medium 0x02: high	0x00	
Switching output – Retroreflective mode offset	64	1	R/W	unit16	UC250: 1 ... 125 UC400: 1 ... 200 UC800: 1 ... 400	UC250: 12 UC400: 20 UC800: 40	mm
Switching output – Switch-off delay	64	2	R/W	unit16	0 ... 60000	0	ms
Switching output – Switch-on delay	64	3	R/W	unit16	0 ... 60000	0	ms
Switching output - Output type	112	1	R/W	unit8	0x00: push-pull 0x01: sourcing (PNP) 0x02: sinking (NPN)	0x00	
Analog output – Near limit	66	1	R/W	unit16	UC250: 20 ... 425 UC400: 30 ... 680 UC800: 60 ... 1200	UC250: 20 UC400: 30 UC800: 60	mm
Analog output – Far limit	66	2	R/W	unit16	UC250: 20 ... 425 UC400: 30 ... 680 UC800: 60 ... 1200	UC250: 250 UC400: 400 UC800: 800	mm
Analog output – Output type	114	1	R/W	unit8	0x00: Current 0x01: Voltage	0x00	
Analog output – Output mode	114	2	R/W	unit8	0x00: Rising ramp 0x01: Falling ramp	0x00	
Analog Output – Lower output value (current)	114	3	R/W	unit8	0 ... 200 (0...20mA)	40	0.1 mA

Name	Index (dec)	Sub-index	Type	Data type	Value	Default value	Unit
Analog output – Upper output value (current)	114	4	R/W	unit8	0 ... 200 (0...20mA)	200	0.1 mA
Analog Output – Lower output value (voltage)	114	5	R/W	unit8	0 ... 100 (0...10V)	0	0.1 V
Analog output – Upper output value (voltage)	114	6	R/W	unit8	0 ... 100 (0...10V)	100	0.1 V
Sensor configuration – Evaluation							
Beam width	97	1	R/W	unit8	0x00: Small 0x01: Medium 0x02: Wide	0x02	
Small beam width	97	2	R/W	unit8	10, 20, 30, 40, 50, 60, 70, 80, 90, 100	50	%
Medium beam width	97	3	R/W	unit8	10, 20, 30, 40, 50, 60, 70, 80, 90, 100	70	%
Wide beam width	97	4	R/W	unit8	10, 20, 30, 40, 50, 60, 70, 80, 90, 100	100	%
Ultrasonic pulse length	97	5	R/W	unit8	0X00: Automatic 0x01: Short pulse 0x02: Long pulse	0x00	
Sensor cycle time	97	6	R/W	unit16	UC250: 7 ... 60000 UC400: 9 ... 60000 UC800: 12 ... 60000	UC250: 7 UC400: 9 UC800: 12	ms
Foreground suppression	97	7	R/W	unit16	UC250: 15 ... 250 UC400: 25 ... 400 UC800: 70 ... 1200	UC250: 15 UC400: 25 UC800: 55	mm
Background suppression	97	8	R/W	unit16	UC250: 15 ... 250 UC400: 25 ... 400 UC800: 70 ... 1200	UC250: 425 UC400: 680 UC800: 1200	mm
Echo evaluation	99	1	R/W	unit8	0x00: First echo 0x01: Strongest echo	0x00	
Evaluation method	99	3	R/W	unit8	0x00: None 0x01: Average value 0x02: Low pass	0x01	
Average value – Averages & Skip count	99	4	R/W	unit8	0x00: M= 2 N= 0 0x01: M= 3 N= 0 0x02: M= 3 N= 1 0x03: M= 4 N= 0 0x04: M= 4 N= 1 0x05: M= 5 N= 0 0x06: M= 5 N= 1 0x07: M= 5 N= 2 0x08: M= 6 N= 0 0x09: M= 6 N= 1 0x0A: M= 6 N= 2 0x0B: M= 7 N= 0 0x0C: M= 7 N= 1 0x0D: M= 7 N= 2 0x0E: M= 7 N= 3 0x0F: M= 8 N= 0 0x10: M= 8 N= 1 0x11: M= 8 N= 2 0x12: M= 8 N= 3	0x07	

2017-06

Name	Index (dec)	Sub-index	Type	Data type	Value	Default value	Unit
Low pass – Weighting of former measurement	99	5	R/W	unit8	1 ... 99	75	%
Low pass – Allowed deviation to former measurement	99	6	R/W	unit8	10 ... 50	10	%
Low pass – Skip time	99	7	R/W	unit16	0 ... 60000	0	ms
Temperature compensation	100	1	R/W	unit8	0x00: disabled 0x01: enabled	0x01	
Operating temperature	100	2	R/W	unit8	-40 ... 100	25	°C
Sensor configuration – Synchronization							
Synchronization mode	101		R/W	unit8	0x00: Automatic multiplex mode 0x01: Automatic common mode 0xFF: Externally controlled	0x00	
Sensor configuration – Echo Loss + error handling							
No echo is	99	2	R/W	unit8	0x00: No error 0x01: Error	0x00	
Switching output – Behavior if error occurs	64	4	R/W	unit8	0: Freeze 1: Max. distance 2: Closed 3: Open	1	
Analog output – Behavior if error occurs	114	7	R/W	unit8	0: Freeze 1: Max. distance 2: Error replacement value	1	
Analog output – Error replacement value (current)	114	8	R/W	unit8	0 ... 200 (0 ... 20 mA)		0.1 mA
Analog output – Error replacement value (voltage)	114	9	R/W	unit8	0 ... 100 (0 ... 10 V)		0.1 V
Sensor configuration – Local controls							
Local controls – Programming button 1	117		R/W	unit8	0x00: Unlocked 0x01: Time locked (5 min) 0x02: Locked	0x01	
Local control status – Programming button 1	236		R	unit32	Bits 0 ... 3: (Mask 0x01 ... 0x08) 0x00: button 1 not pushed 0x01: button 1 pushed		

Name	Index (dec)	Sub-index	Type	Data type	Value	Default value	Unit
Echo suppression							
Echo suppression	98	1	R/W	unit8	0x00: disabled 0x01: enabled	0x00	
Suppression area 1 – Start point	98	2	R/W	unit16	UC250: 0 ... 425 UC400: 0 ... 680 UC800: 0 ... 1200	0	mm
Suppression area 1 – Amplitude	98	3	R/W	unit8	0 ... 100	0	%
Suppression area 1 – Length	98	4	R/W	unit16	UC250: 0 ... 425 UC400: 0 ... 680 UC800: 0 ... 1200	0	mm
Suppression area 2 – Start point	98	5	R/W	unit16	UC250: 0 ... 425 UC400: 0 ... 680 UC800: 0 ... 1200	0	mm
Suppression area 2 – Amplitude	98	6	R/W	unit8	0 ... 100	0	%
Suppression area 2 – Length	98	7	R/W	unit16	UC250: 0 ... 425 UC400: 0 ... 680 UC800: 0 ... 1200	0	mm
Suppression area 3 – Start point	98	8	R/W	unit16	UC250: 0 ... 425 UC400: 0 ... 680 UC800: 0 ... 1200	0	mm
Suppression area 3 – Amplitude	98	9	R/W	unit8	0 ... 100	0	%
Suppression area 3 – Length	98	10	R/W	unit16	UC250: 0 ... 425 UC400: 0 ... 680 UC800: 0 ... 1200	0	mm
Suppression area 4 – Start point	98	11	R/W	unit16	UC250: 0 ... 425 UC400: 0 ... 680 UC800: 0 ... 1200	0	mm
Suppression area 4 – Amplitude	98	12	R/W	unit8	0 ... 100	0	%
Suppression area 4 – Length	98	13	R/W	unit16	UC250: 0 ... 425 UC400: 0 ... 680 UC800: 0 ... 1200	0	mm
Suppression area 5 – Start point	98	14	R/W	unit16	UC250: 0 ... 425 UC400: 0 ... 680 UC800: 0 ... 1200	0	mm
Suppression area 5 – Amplitude	98	15	R/W	unit8	0 ... 100	0	%
Suppression area 5 – Length	98	16	R/W	unit16	UC250: 0 ... 425 UC400: 0 ... 680 UC800: 0 ... 1200	0	mm
Suppression area 6 – Start point	98	17	R/W	unit16	UC250: 0 ... 425 UC400: 0 ... 680 UC800: 0 ... 1200	0	mm
Suppression area 6 – Amplitude	98	18	R/W	unit8	0 ... 100	0	%

2017-06

Name	Index (dec)	Sub-index	Type	Data type	Value	Default value	Unit
Suppression area 6 – Length	98	19	R/W	unit16	UC250: 0 ... 425 UC400: 0 ... 680 UC800: 0 ... 1200	0	mm
Suppression area 7 – Start point	98	20	R/W	unit16	UC250: 0 ... 425 UC400: 0 ... 680 UC800: 0 ... 1200	0	mm
Suppression area 7 – Amplitude	98	21	R/W	unit8	0 ... 100	0	%
Suppression area 7 – Length	98	22	R/W	unit16	UC250: 0 ... 425 UC400: 0 ... 680 UC800: 0 ... 1200	0	mm
Suppression area 8 – Start point	98	23	R/W	unit16	UC250: 0 ... 425 UC400: 0 ... 680 UC800: 0 ... 1200	0	mm
Suppression area 8 – Amplitude	98	24	R/W	unit8	0 ... 100	0	%
Suppression area 8 – Length	98	25	R/W	unit16	UC250: 0 ... 425 UC400: 0 ... 680 UC800: 0 ... 1200	0	mm
Suppression area 9 – Start point	98	26	R/W	unit16	UC250: 0 ... 425 UC400: 0 ... 680 UC800: 0 ... 1200	0	mm
Suppression area 9 – Amplitude	98	27	R/W	unit8	0 ... 100	0	%
Suppression area 9 – Length	98	28	R/W	unit16	UC250: 0 ... 425 UC400: 0 ... 680 UC800: 0 ... 1200	0	mm
Suppression area 10 – Start point	98	29	R/W	unit16	UC250: 0 ... 425 UC400: 0 ... 680 UC800: 0 ... 1200	0	mm
Suppression area 10 – Amplitude	98	30	R/W	unit8	0 ... 100	0	%
Suppression area 10 – Length	98	31	R/W	unit8	UC250: 0 ... 425 UC400: 0 ... 680 UC800: 0 ... 1200	0	mm
IO-Link events							
IO-Link event – No echo error	120	1	R/W	bool	0xx00: disabled 0x01: enabled	0x00	
IO-Link event – Ambient noise error	120	2	R/W	bool	0xx00: disabled 0x01: enabled	0x00	
IO-Link event – Hardware error	120	3	R/W	bool	0xx00: disabled 0x01: enabled	0x00	

FACTORY AUTOMATION – SENSING YOUR NEEDS



Worldwide Headquarters

Pepperl+Fuchs GmbH
68307 Mannheim · Germany
Tel. +49 621 776-0
E-mail: info@de.pepperl-fuchs.com

USA Headquarters

Pepperl+Fuchs Inc.
Twinsburg, Ohio 44087 · USA
Tel. +1 330 4253555
E-mail: sales@us.pepperl-fuchs.com

Asia Pacific Headquarters

Pepperl+Fuchs Pte Ltd.
Company Registration No. 199003130E
Singapore 139942
Tel. +65 67799091
E-mail: sales@sg.pepperl-fuchs.com

www.pepperl-fuchs.com

 **PEPPERL+FUCHS**
SENSING YOUR NEEDS