

## Technical Manual

### **Operation Workstation**

**VisuNet EX1 Remote Monitor  
(RM519)**

**VisuNet EX1 Panel PC  
(PC419)**



With regard to the supply of products, the current issue of the following document is applicable: The General Terms of Delivery for Products and Services of the Electrical Industry, published by the Central Association of the Electrical Industry (Zentralverband Elektrotechnik und Elektroindustrie (ZVEI) e.V.) in its most recent version as well as the supplementary clause: "Expanded reservation of proprietorship"

## Table of Content

1	Important Information .....	2
1.1	General Information .....	2
1.2	Safety Instructions .....	3
2	Differences between PC4xx and RM5xx .....	4
3	System Overview of the VisuNet RM/PC in Hazardous Area .....	5
4	Front View VisuNet PC an VisuNet RM.....	6
4.1	PC4xx .....	6
4.2	RM5xx .....	6
5	Rear View VisuNet RM and VisuNet PC .....	7
6	Connecting and Wiring Diagrams .....	8
6.1	Terminal Compartment X1 (Ex e) (Terminal Pin Assignment) .....	8
6.1.1	Network Connection Ethernet (X1) .....	9
6.1.2	Wiring Diagram of the Setup Cable to the USB Interface (Ex e) .....	10
6.2	Terminal Compartment X2 (Ex ib) (Terminal Pin Assignment).....	11
7	VisuNet RM and VisuNet PC .....	12
7.1	Screen VisuNet RM and VisuNet PC.....	12
7.2	Front-Plate Keys VisuNet PC .....	12
8	Case Design VisuNet RM and VisuNet PC .....	14
8.1	General Installation Instruction VisuNet RM and VisuNet PC .....	14
8.2	Cutout for Panel Mounting VisuNet 19" .....	15
8.3	Stainless Steel Housing for 19" VisuNet RM and VisuNet PC .....	17
8.4	Rear View VisuNet Stainless Steel Case for 19" with Drilling Pattern for Wall Mount Bracket Wall-Bracket5 .....	18
8.5	Bottom View VisuNet Stainless Steel Case for 19" .....	19
8.6	Mounting PE Bolt to the Housing (Optional) .....	19
8.7	Keyboard Connection .....	19
8.7.1	Option – F: VisuNet RM, VisuNet PC 19" .....	20
8.7.2	Option – T: Desktop Keyboard to VisuNet .....	21
8.7.3	Keyboard for Panel Mounting .....	22

8.8	Information for Positioning VisuNet Devices in Housing with BasicLine Pedestal ..	23
8.9	Information for Positioning VisuNet Devices in Housing .....	24
8.10	Accessories for Mounting Stainless Steel Case AGx .....	24
8.10.1	Direct Wall Mount Bracket for Stainless Steel Case AGx.....	25
8.10.2	BasicLine Floor Mount for Stainless Steel Housing AGx.....	26
8.10.3	Floor Mount for Stainless Steel Housing AGx .....	27
9	Accessories VisuNet RM and VisuNet PC .....	43
9.1	Barcode Reader.....	43
9.1.1	Holder for Barcode Reader .....	44
9.2	BOX-A10 (Ethernet RJ45 1 Off Patch Field Element).....	50
9.2.1	Connection Instructions.....	51
9.2.2	Technical Data Box A10.....	54
9.2.3	Connection Instructions VisuNet RM/PC.....	55
9.3	PC Keyboard Intrinsically Safe (Components Optional) .....	56
10	Installation VisuNet RM and VisuNet PC.....	57
10.1	General Instructions and Explosion Protection Requirements .....	57
10.2	External Equipotential Bonding .....	57
10.3	Cable Types and Maximum Cable Lengths.....	57
10.3.1	Ethernet 100BASE-TX (Ex e) .....	57
10.3.2	USB (Ex e) .....	60
10.3.3	RS 422 (Ex e).....	60
10.3.4	RS 232 (Ex e).....	60
10.3.5	RS485 Interface (Ex e).....	60
10.3.6	External Keyboard (Ex ib) .....	60
10.3.7	Mouse (Ex ib) .....	60
10.3.8	20 mA TTY-Interface (Ex ib) e.g. Scanner.....	60
10.3.9	VisuNet Power Supply Cable (24V DC) .....	61
10.4	Shielding of Data Cables.....	61
10.4.1	Shielding Concept.....	61
10.4.2	Assembly Instructions for Ex EMC Cable Glands .....	63

11 Accessories..... 64

    11.1 Box A-10 (Ethernet RJ45 1 Off Patch Field Element) ..... 64

    11.2 Holder for Barcode Reader ..... 64

    11.3 Cables ..... 64

    11.4 Fuse Set ..... 64

    11.5 Jack 4W ..... 64

    11.6 Pedestal/Support-Arm/Ceiling..... 65

    11.7 Pedestal BasicLine ..... 65

    11.8 Keyboards EXTA2 ..... 65

    11.9 Packing Set: VisuNet Front Plate Protection ..... 66

12 Replace a Blown Fuse..... 67

13 Dictionary for VisuNet..... 68

# 1 Important Information

## 1.1 General Information

Copyright 2007-2015 by Pepperl+Fuchs GmbH

All rights reserved

The publisher reserves the right to alter the information and data contained in this manual without prior notice. Unless otherwise indicated, the company names as well as other names and data used in the examples are purely fictitious.

The publisher may have registered patents or pending patent applications for subject matter covered in the manual. This manual does not give you license to these patents.

Limited warranty:

No warranty is provided for the accuracy of the information contained in this manual. As mistakes cannot be entirely avoided despite taking the greatest of care, we would be grateful to receive information about any errors you may discover. The publisher disclaims all legal responsibility or liability for errors as well as for subsequent damages and claims.

Microsoft, MS, MS-DOS, Windows 2000, Windows XP Professional, Windows XP embedded, Windows 7 Ultimate are registered trademarks of the Microsoft Corporation.

Manufacturer:

Pepperl-Fuchs GmbH  
Lilienthalstr. 200  
68307 Mannheim  
Germany

[www.pepperl-fuchs.com](http://www.pepperl-fuchs.com)

Tel. 0621-776-0

Fax 0621-776-1000

E-Mail: [info@de.pepperl-fuchs.com](mailto:info@de.pepperl-fuchs.com)



## 1.2 Safety Instructions

Please refer to the operation instructions for the safety instructions.

## 2 Differences between PC4xx and RM5xx

The VisuNet product family is a series of rugged operator workstations for the process industry based on high-resolution color graphic LCD monitors.

The following table provides an overview of the VisuNet family and its two product lines: Remote Monitor (RM5xx) and Panel PC (PC4xx).

The Remote Monitor RM5xx allows operating an automation PC installed at a distant location in the safe area (e.g. the PC of a process control system) and its user programs via an Ethernet TCP/IP connection. It comprises an industry-standard display, keyboard, and mouse.

The Panel PC PC4xx consists as well of a display, keyboard, mouse and additionally includes a powerful industrial PC featuring the standard Windows operating system and a solid state disk (SSD). It can be connected to the process system either using an Ethernet cable or via a serial RS 485 or RS 422 port and the appropriate automation protocols. The operator control and monitoring software (e.g. SCADA) is directly installed on that panel PC.

Criteria	VisuNet RM5xx	VisuNet PC4xx
Front panel design (Stainless Steel): Keys LED	No keys No LED	6+2 keys 3 LED
Storage media: SSD Flash disc RAM	 x x	 x
Processor	Intel® ATOM	Intel® Core™ 2 Duo
Interfaces	Chapter 6 Reduced options	Chapter 6
Display size	19"	19"
Mounting Options: Panel mounting Wall bracket Pedestal Ceiling 7 support arm	 x x (optional) x (optional) x (optional)	 x x (optional) x (optional) x (optional)
Material front-plate: Stainless steel 1.4301 (304), standard Stainless steel 1.4571 (316Ti), on request	 x x (optional)	 x x (optional)
Operating system: Windows XP embedded Windows XP Prof. Multilingual Windows 7 Ultimate	 x	 x x
Software package (preinstalled): - Hotkey Tool - Start menu - Smart monitor (harddisc) - System recovery - Language settings - Refresh Display - Factory Reset - Clean Disk - Set up Menu	      x  x	 x x x (not with SSD) x (not with SSD) x x x x (not with SSD)

2015-01



### 3 System Overview of the VisuNet RM/PC in Hazardous Area

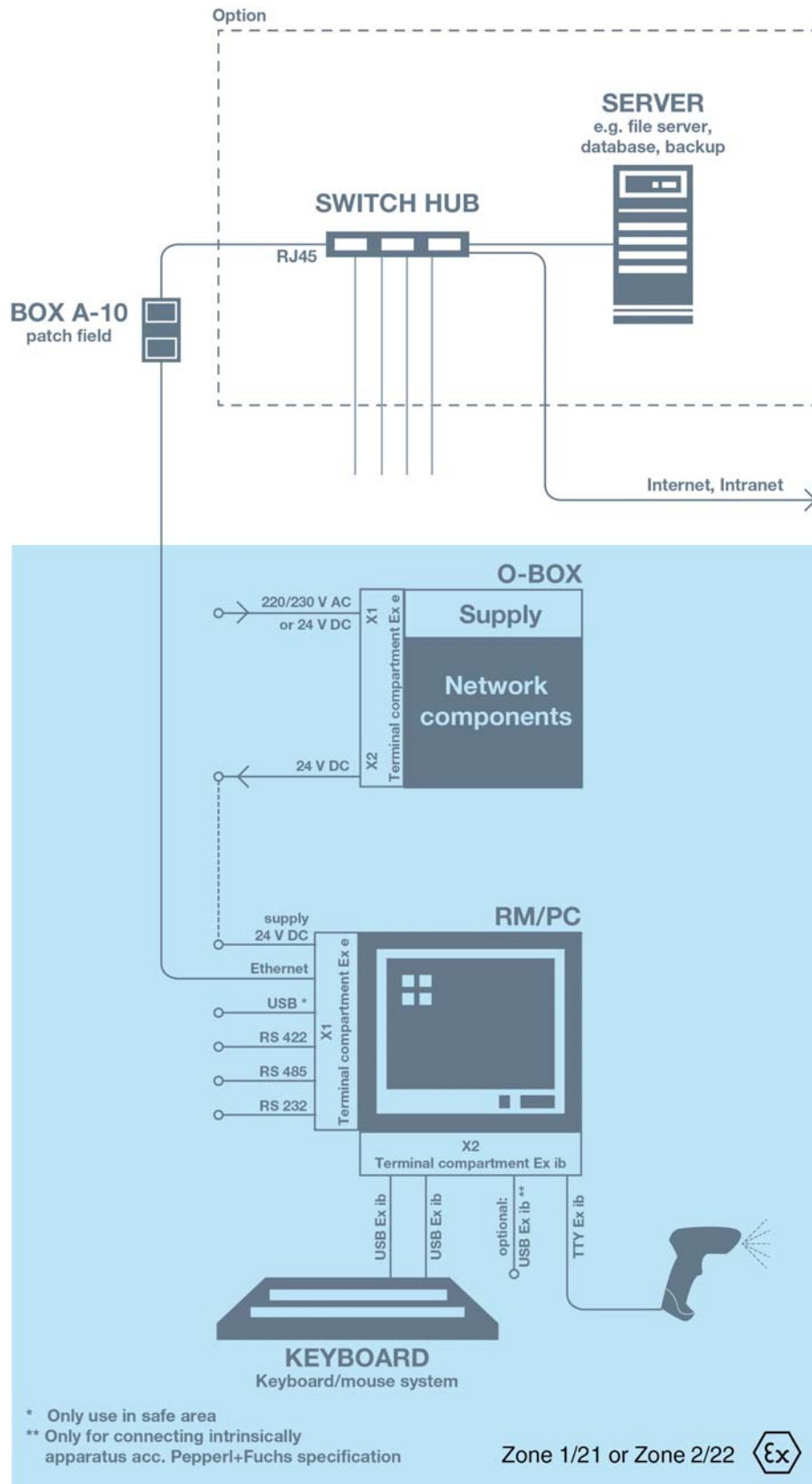

2015-01



## 4 Front View VisuNet PC an VisuNet RM

### 4.1 PC4xx

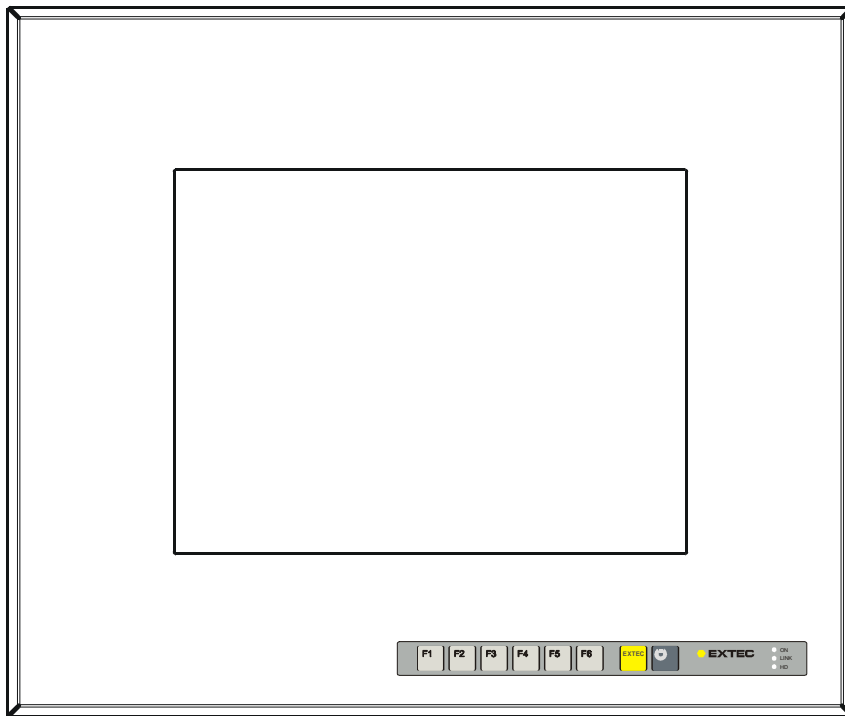

### 4.2 RM5xx

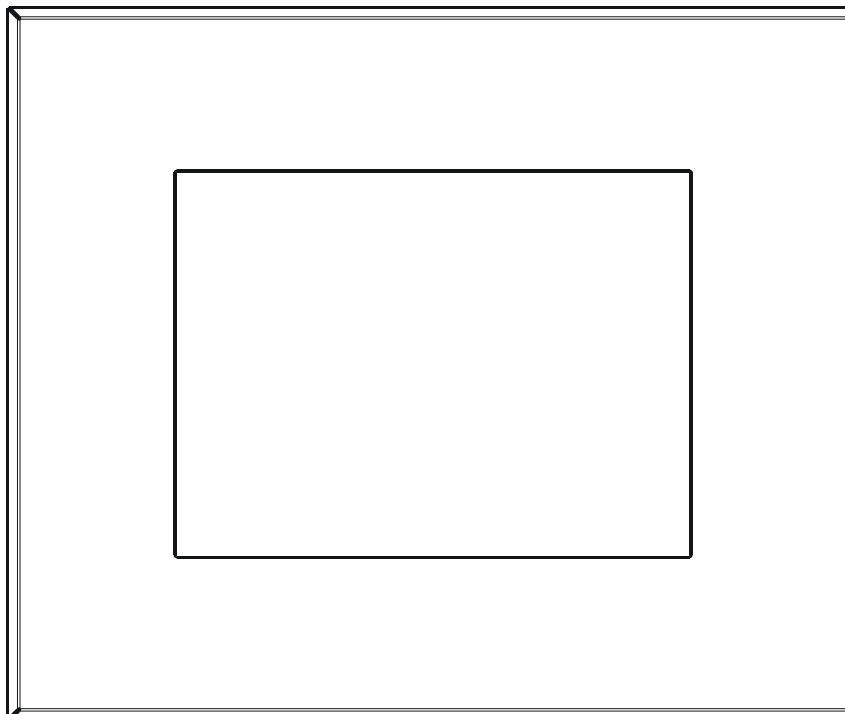

## 5 Rear View VisuNet RM and VisuNet PC

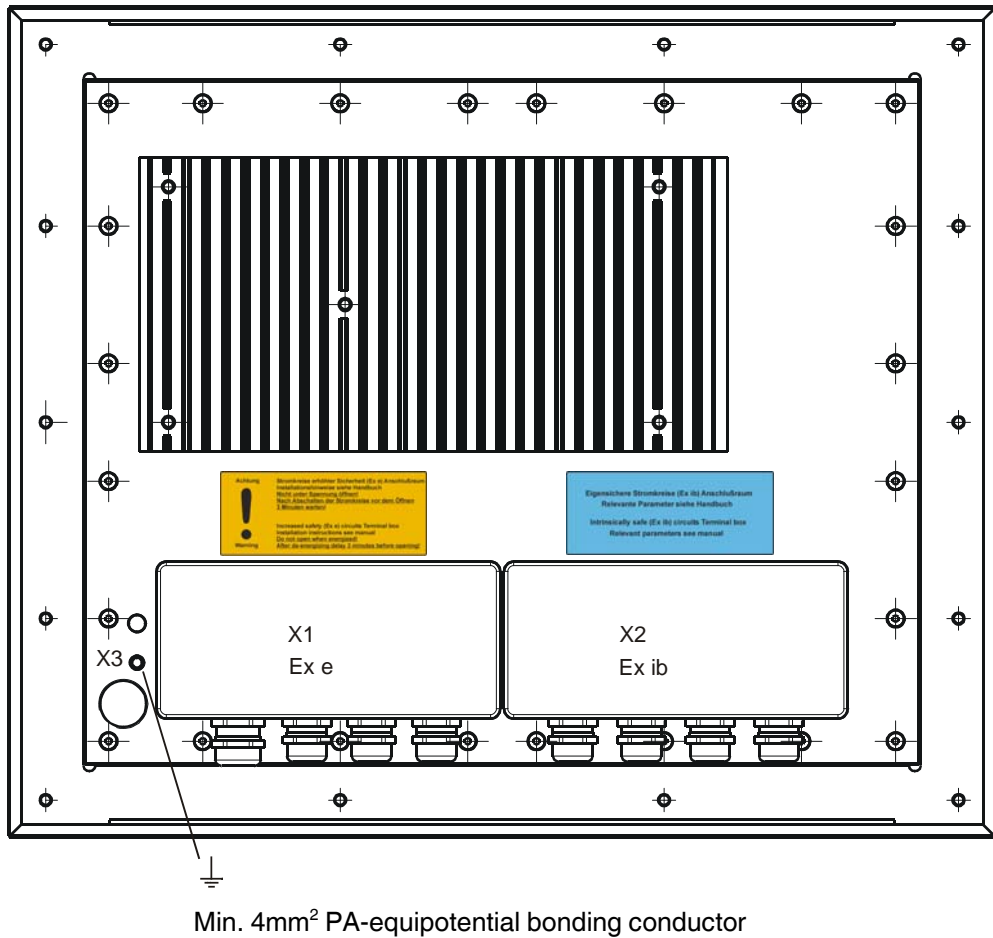

**Warning!**

Please refer to the operation instructions for all safety relevant information that must be considered for installation and operation of these devices!

**Achtung**

**Stromkreise erhöhter Sicherheit (Ex e) Anschlußraum**  
 Installationshinweise siehe Handbuch  
**Nicht unter Spannung öffnen!**  
 Nach Abschalten der Stromkreise vor dem Öffnen  
 3 Minuten warten!

Increased safety (Ex e) circuits Terminal box  
 Installation instructions see manual  
**Do not open when energized!**  
 After de-energizing delay 3 minutes before opening!

**Warning**

**Eigensichere Stromkreise (Ex ib) Anschlußraum**  
 Relevante Parameter siehe Handbuch

**Intrinsically safe (Ex ib) circuits Terminal box**  
 Relevant parameters see manual

## 6 Connecting and Wiring Diagrams

### 6.1 Terminal Compartment X1 (Ex e) (Terminal Pin Assignment)

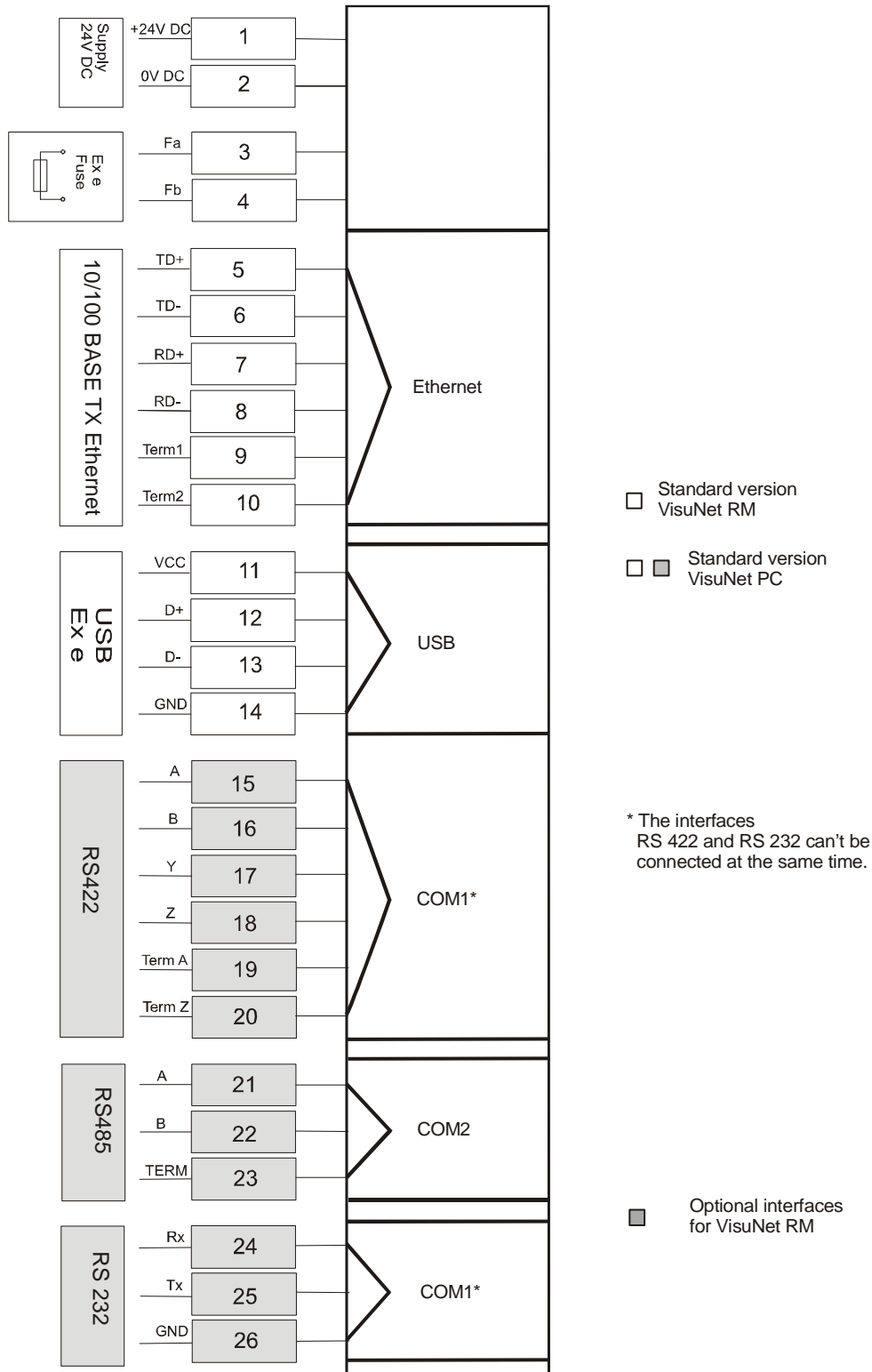

(10/100 BASE TX Ethernet cable: DATL-CAT71-8-2, recommendation for cable see chap. 10.3.1)

### 6.1.1 Network Connection Ethernet (X1)

#### VisuNet RM and VisuNet PC

(10/100 BASE TX Ethernet cable: DATL-CAT71-8-2, recommendation for cable see chap.10.3.1)

**Version 1:** with component: Box-A10 (max over all distance: max. 90m over all)

Connection instruction Box-A10 see chap. 9.2

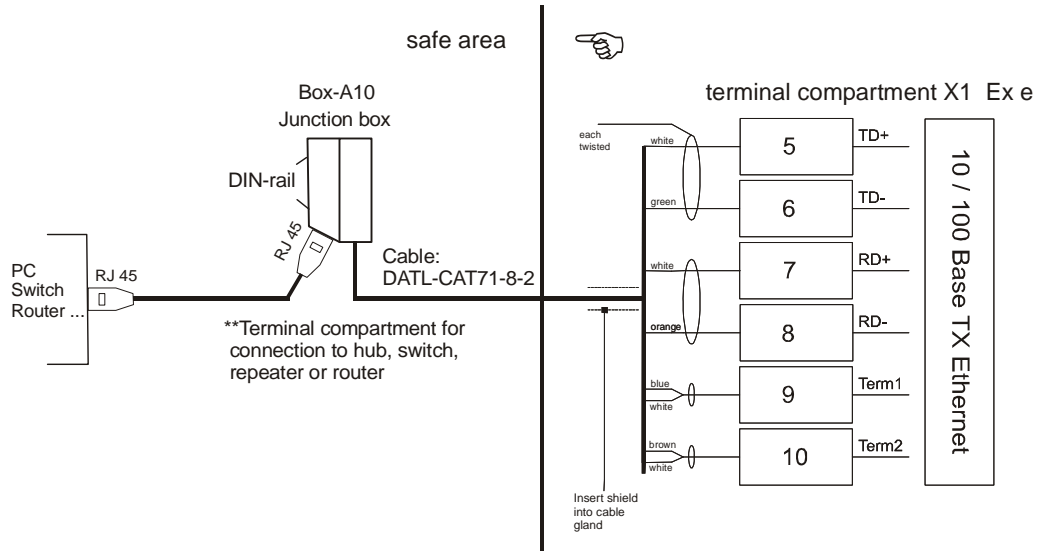

The cable shield has to be connected in the cable gland. (see chap. 10.4.2)

**Version 2:** with component: Cable DATL-C/TP-1-1RJ45 (distance: max. 90m)

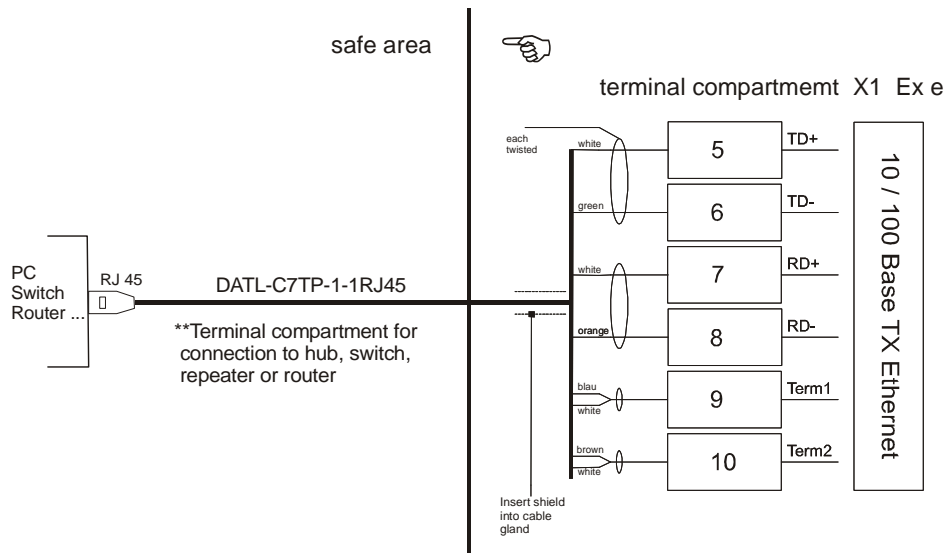

The cable shield has to be connected in the cable gland. (see chap. 10.4.2)

**Version 3:** with component: Start-up cable S-RJ45/PCEX-1-Setup-Kabel  
(distance: max. 2,5 m)

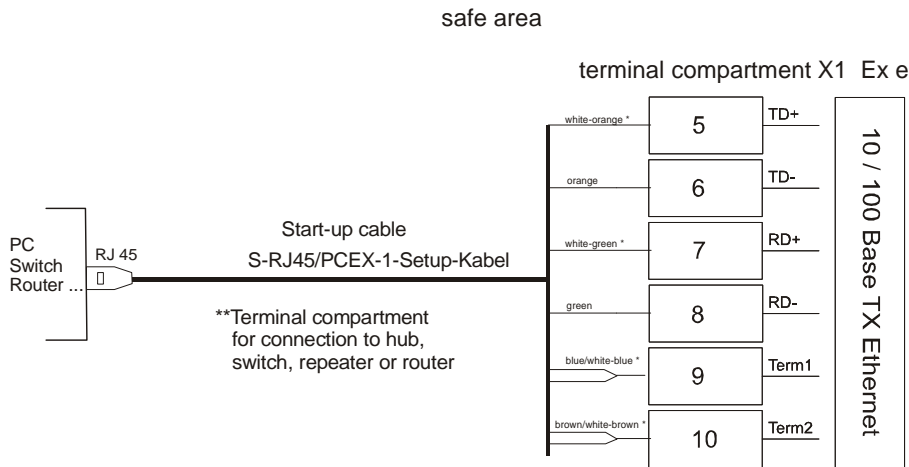

**Warning!**

Start-up cable S-RJ45/PCEX-1-Setup-Kabel  
Don't use in the hazardous area!

\* also possible: for line coding, use "black" Instead of "white".

\*\* For direct connection to a host or PC, the pairs of wires (white-orange / orange) and (white-green / green) must be interchanged.

## 6.1.2 Wiring Diagram of the Setup Cable to the USB Interface (Ex e)

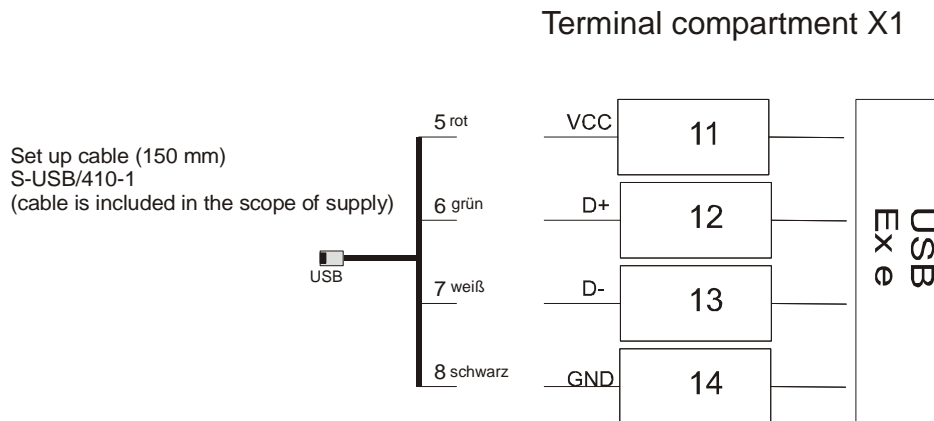

**Warning!**

Start-up cable S-RJ45/PCEX-1-Setup-Kabel  
Don't use in the hazardous area!

## 6.2 Terminal Compartment X2 (Ex ib) (Terminal Pin Assignment)

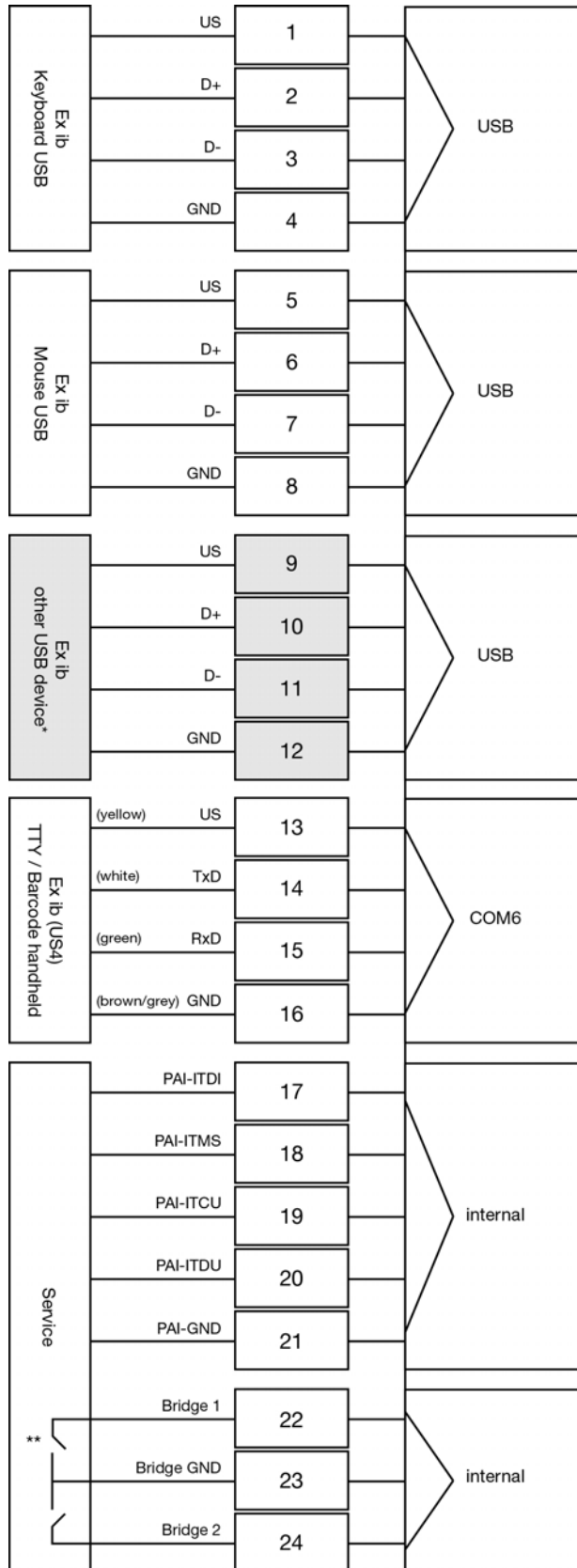

\* Interface to connect additional compatible USB Ex ib device

\*\* Close bridge to enable Power Off via front-plate keyboard

Wiring conditions considered acc.EN 60079-14

2015-01

## 7 VisuNet RM and VisuNet PC

### 7.1 Screen VisuNet RM and VisuNet PC

The screen has a CCFL backlight.

During direct sun exposure the visibility of the display can be reduced. Always protect the system from direct sunlight.

An optional touchscreen allows the direct interaction with the application software.



**Note!**

**Image Sticking of LCDs**

Displaying a fixed image may cause burn-in-effects. (image sticking due to the LCD characteristics). To avoid image sticking change pattern frequently or activate screen saver.

Please note that display damages at the display caused by burn-in-effects are not covered by warranty.

### 7.2 Front-Plate Keys VisuNet PC

A service for defining function keys F1 ... F6 and shortcuts is installed on the VisuNet PC4xx. Among others, this allows to start applications with the function keys or change the assignment of key codes to keys (refer to Software Manual chapters Hotkey Tool).



Light indicators of the front plate keyboard provide following system information:

LED	Function
on	Power on
Link	Link established
HD	Hard disk activity



**Note!**

All 3 LEDs on: Device is warming up

After warming up and going off of the 3 LEDs the device could be started with the “Power on” button.



## Power On

PC systems can be started by pressing the following key combination:



**Note!**

Systems built before January 2014 can also be started by pressing the power button.



**Note!**

Systems can be switched off with the same key combination when bridge 1 in terminal compartment X2 is closed ( see chapter 6.2).

Pressing the shortcut	Default Settings
	F1
	F6
+	F7
+	F12

## 8 Case Design VisuNet RM and VisuNet PC

### 8.1 General Installation Instruction VisuNet RM and VisuNet PC

The device must be installed carefully in accordance with the general explosion protection regulations.

**19"**

Material front plate: Stainless steel 1.4301 (304)

Optional on request: Stainless steel 1.4571 (316Ti) / 1.4404 (316L)

Weight: approx. 41 kg

Optional: Touch screen

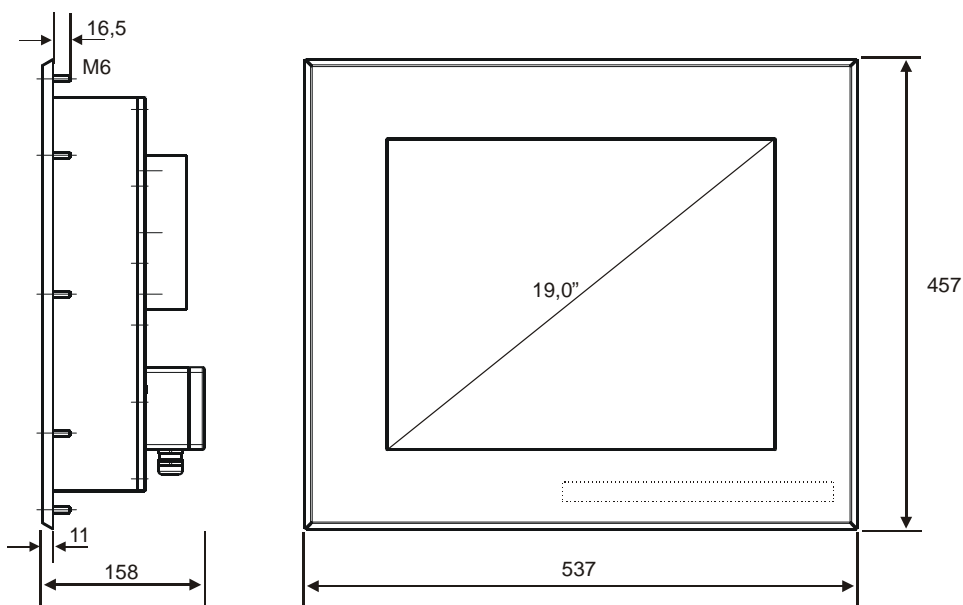

8.2 Cutout for Panel Mounting VisuNet 19"

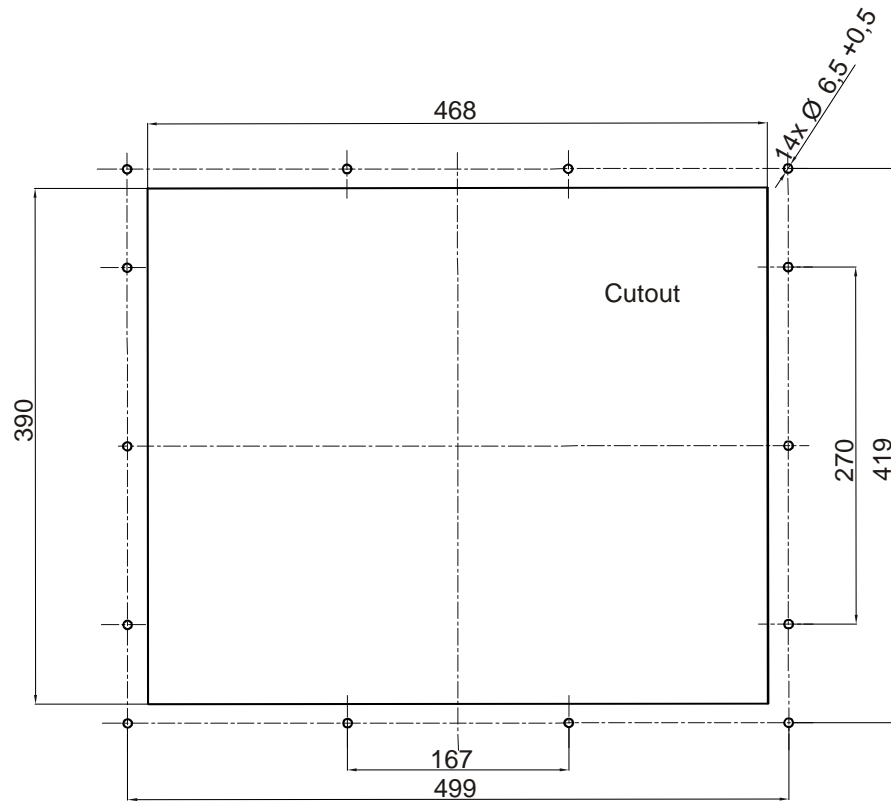

2015-01

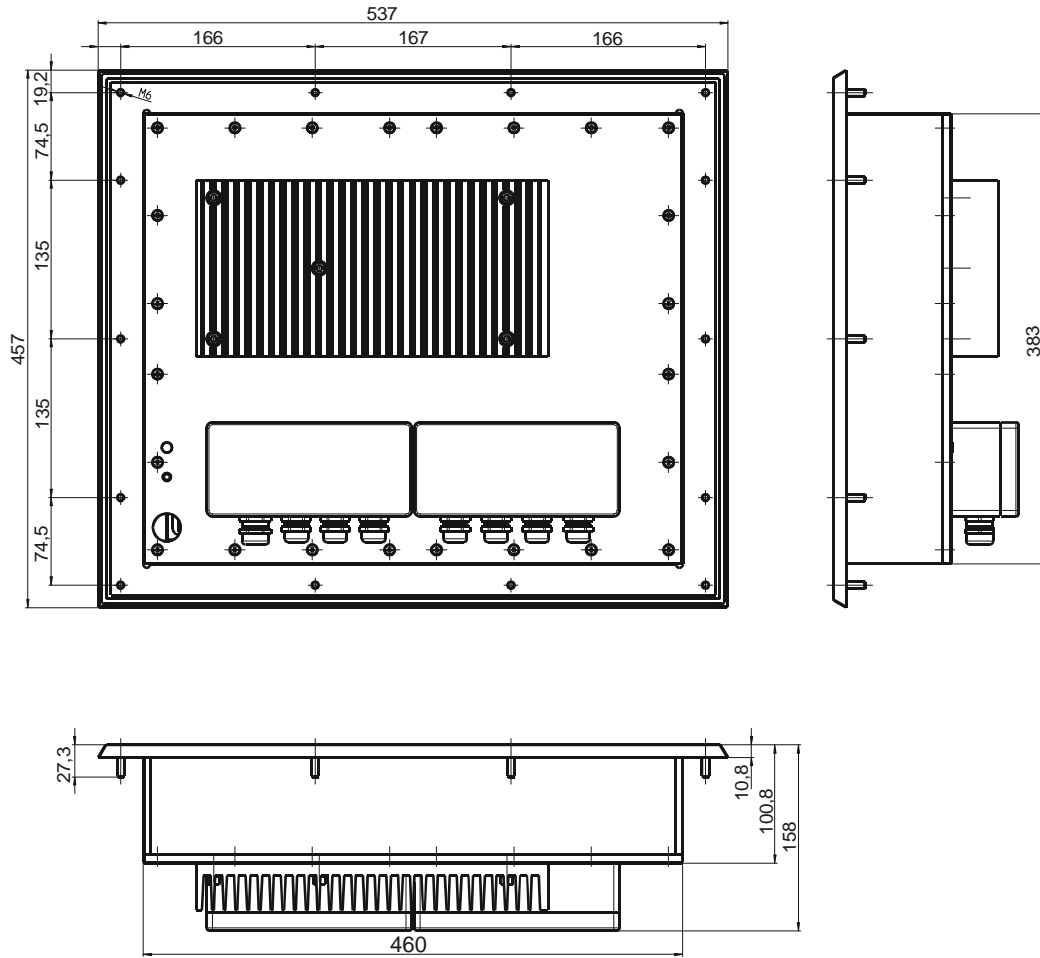

### 8.3 Stainless Steel Housing for 19" VisuNet RM and VisuNet PC

For further technical details please refer to AG1 datasheet.

#### Stainless Steel Housing AG1

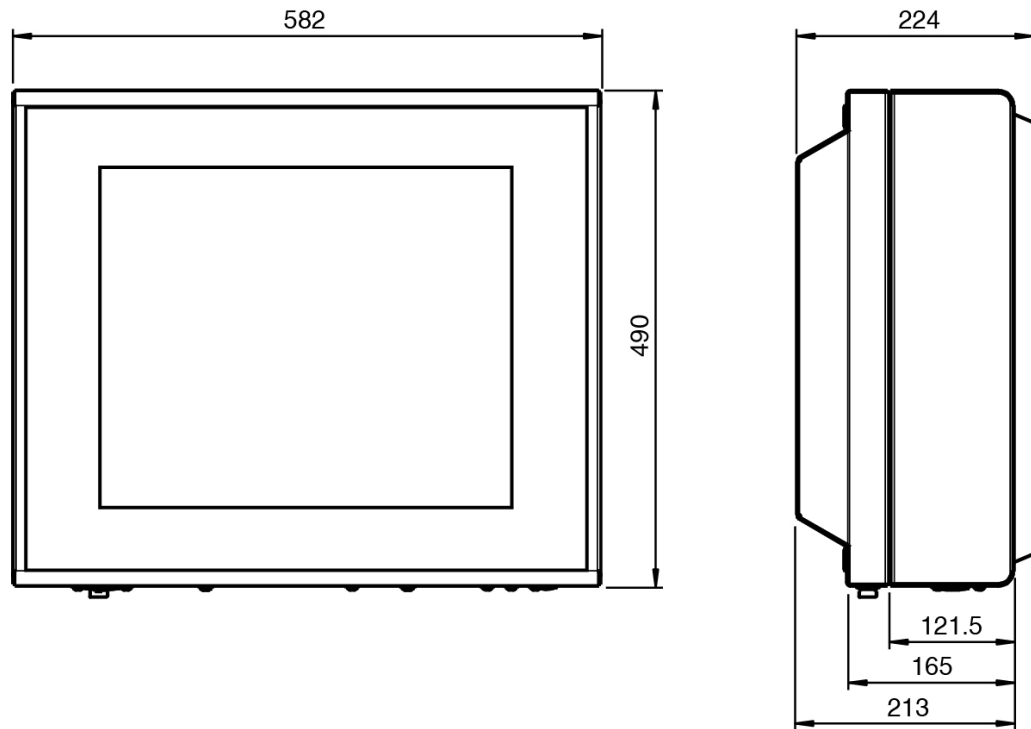

8.4 Rear View VisuNet Stainless Steel Case for 19" with Drilling Pattern for Wall Mount Bracket Wall-Bracket5 (Wall-Bracket5 included in the wall mount version of housing)

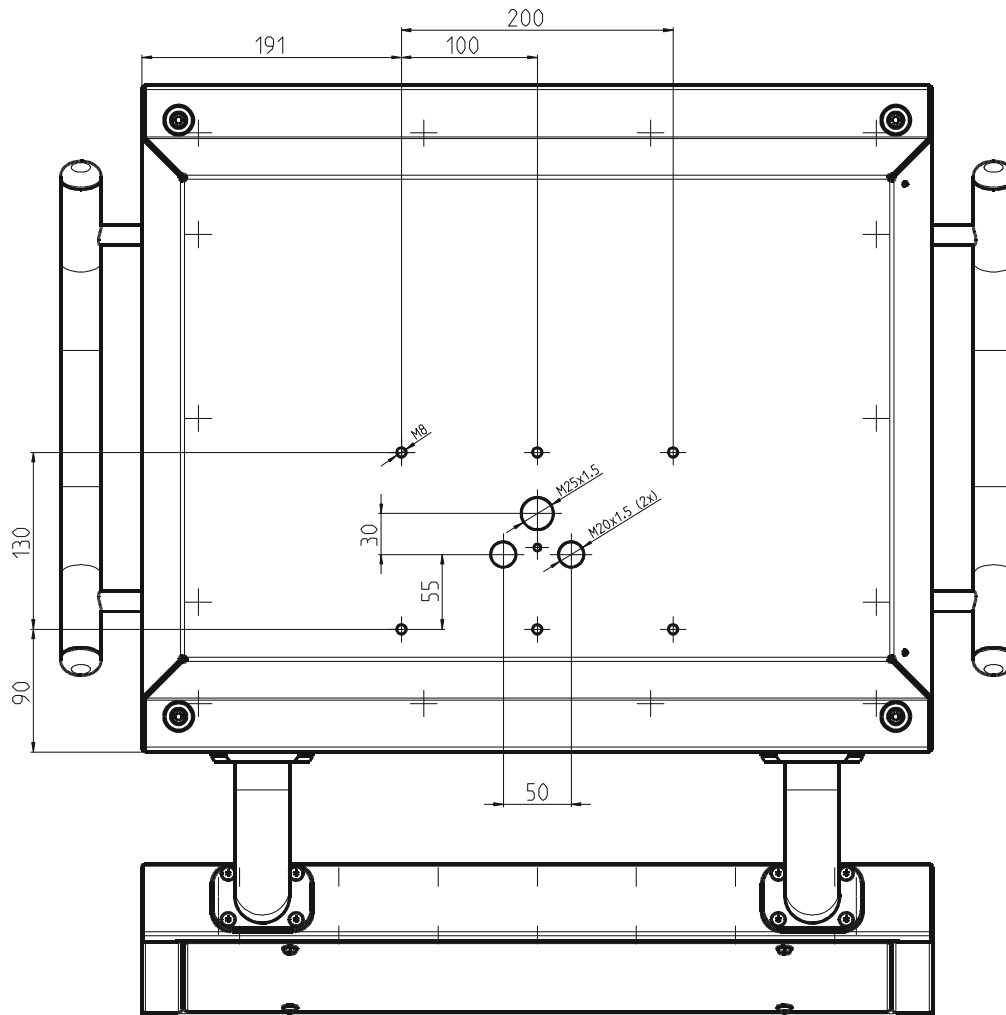

(all dimensions in mm)

(Up to version 12.2010 delivery with 3 x M 20)

### 8.5 Bottom View VisuNet Stainless Steel Case for 19"

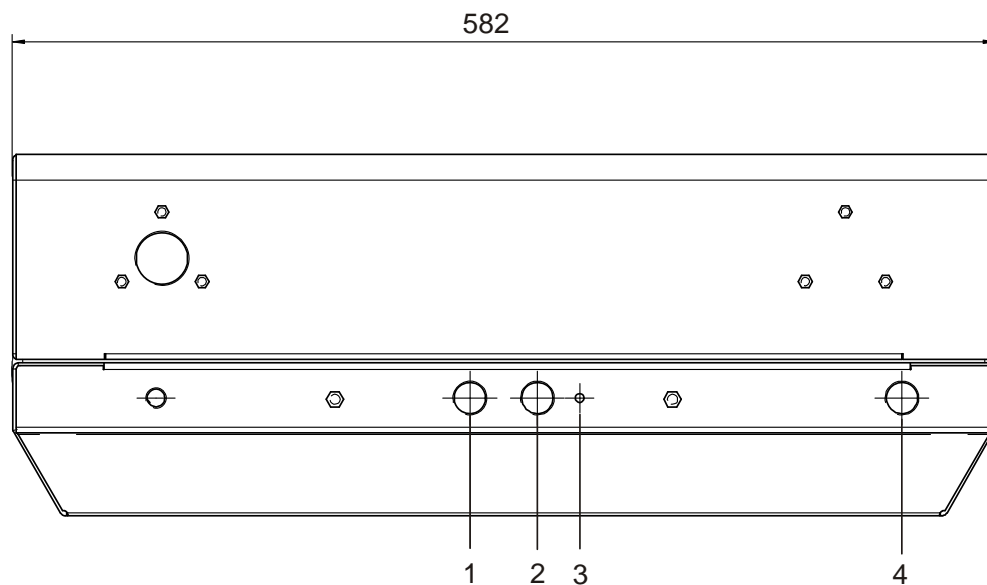

- 1 M 20 (for cable gland)
- 2 M 20 (for cable gland)
- 3 for PE bolt
- 4 (for barcode reader optional)

### 8.6 Mounting PE Bolt to the Housing (Optional)

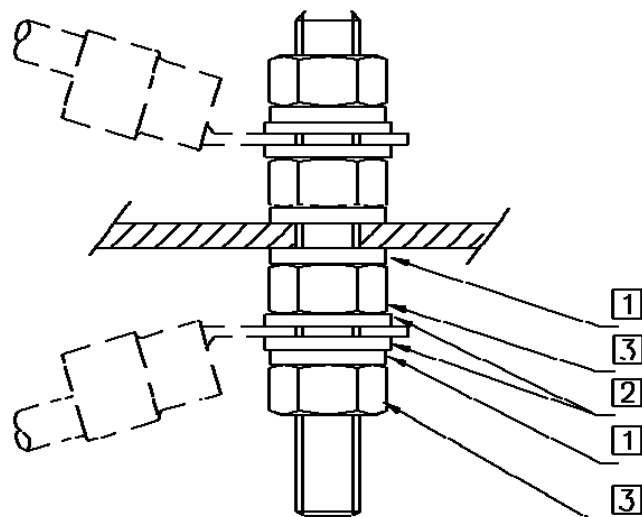

- 1 lock washer
- 2 washer
- 3 nut

### 8.7 Keyboard Connection

Weight: Housing for keyboard including connection	4 kg
---	------

2015-01

8.7.1 Option – F: VisuNet RM, VisuNet PC 19”

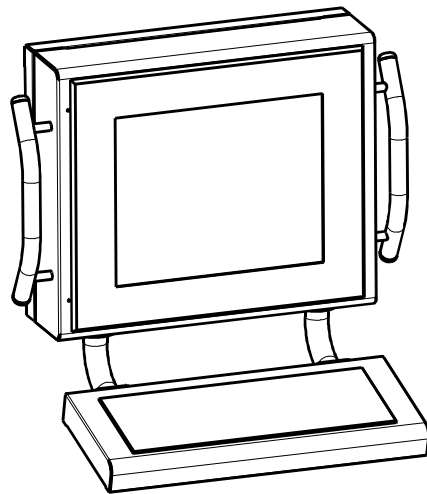
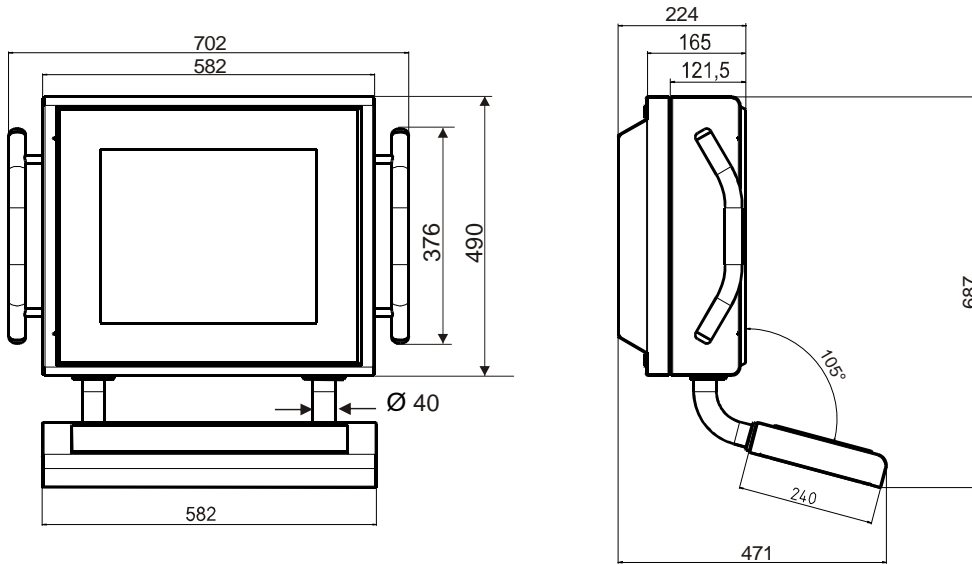



### 8.7.2 Option – T: Desktop Keyboard to VisuNet (or Accessory TASTEX, option T)

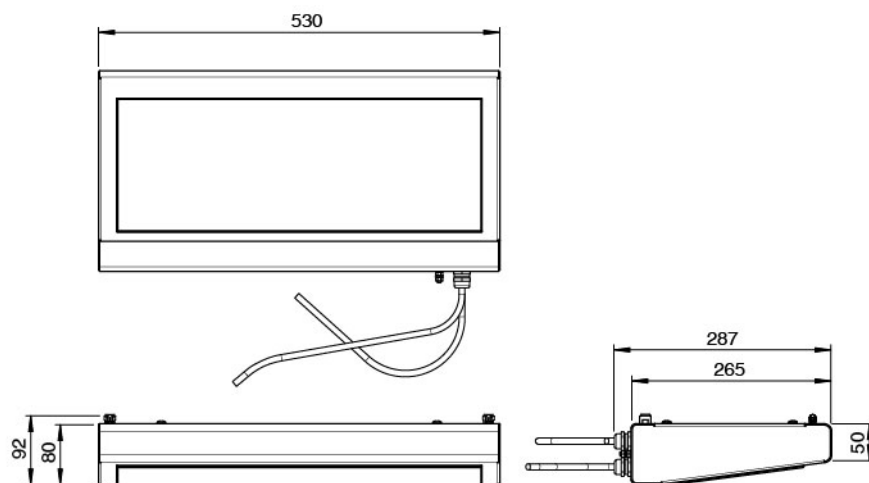

**Warning!**

The housing must always be connected to the PE.

There are 2 possibilities:

- 1.) Connection via cable shielding of the connecting cable.
- 2.) Connection via a separate grounding cable  
(min. 4 mm<sup>2</sup>) to the PE connecting bolt of the keyboard.

### 8.7.3 Keyboard for Panel Mounting

(Accessory to the product line TASTEX, version N)

Keyboard dimension drawing

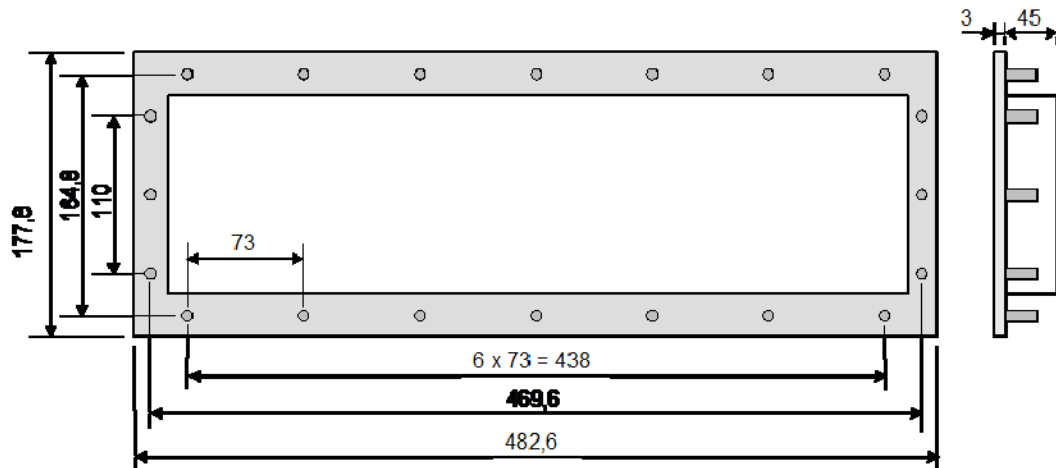

#### **Warning!**

The housing must always be connected to the PE.

There are 2 possibilities:

- 1.) Connection via cable shielding of the connecting cable.
- 2.) Build into a metal housing which is connected with the PE.

## 8.8 Information for Positioning VisuNet Devices in Housing with BasicLine Pedestal



**Note!**

On positioning VisuNet RM/PC devices a distance of min. 700 mm swiveling range between housing and behind wall has to be observed for mounting and opening. A distance of min. 100 mm between housing and left wall has to be observed, too.

Distance of behind wall

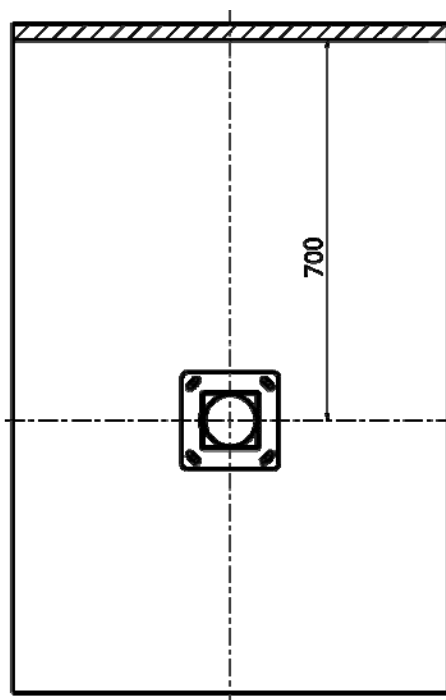

Distance of the left wall

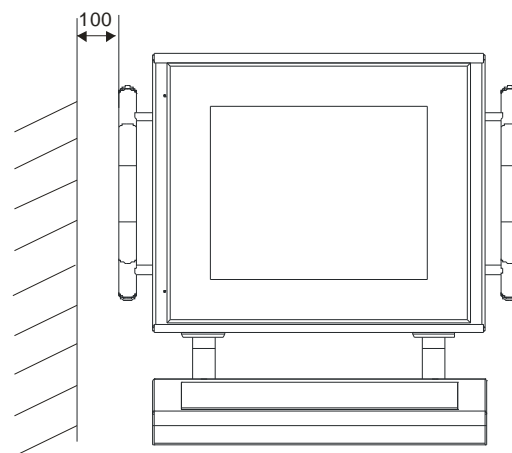

(Dimensions in mm)

## 8.9 Information for Positioning VisuNet Devices in Housing



### **Note!**

On positioning VisuNet devices a distance of min. 350 mm swivelling range between housing and left wall has to be observed.

Distance min.

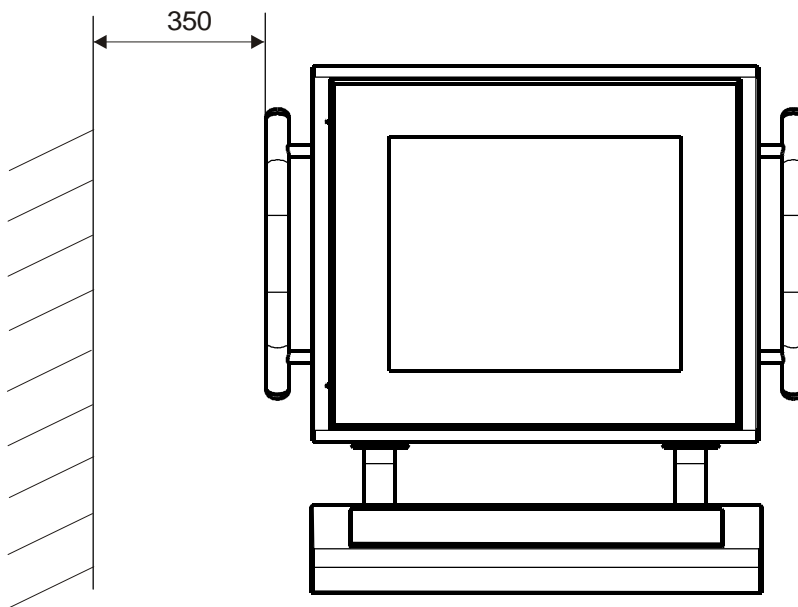

## 8.10 Accessories for Mounting Stainless Steel Case AGx

There are the following accessories for mounting VisuNet stainless steel case AGx:

- Direct wall mount bracket
- Floor mount
- Wall mount
- Ceiling mount

Direct wall mount bracket for stainless steel case AGx

### 8.10.1 Direct Wall Mount Bracket for Stainless Steel Case AGx

Naming: Wall-Bracket5 (included in the wall mount version of housing)

The wall mount bracket has the following dimensions:

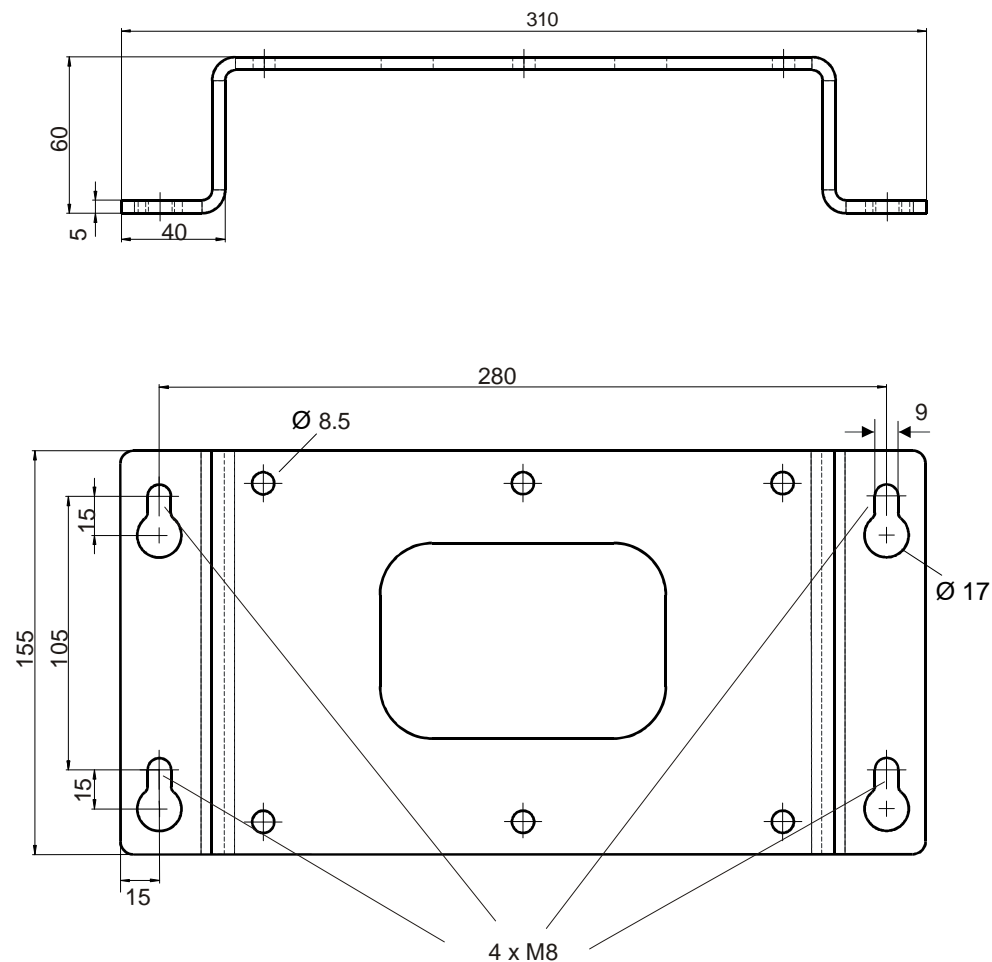

**Note!**

On positioning VisuNet devices a distance of min. 350 mm swivelling range between housing and left wall has to be observed. (refer chapter 8.12).

### 8.10.2 BasicLine Floor Mount for Stainless Steel Housing AGx

Order designation: PEDESTAL5-1458-FIX-BL

Pedestal fix, stainless steel 1.4301 (304)

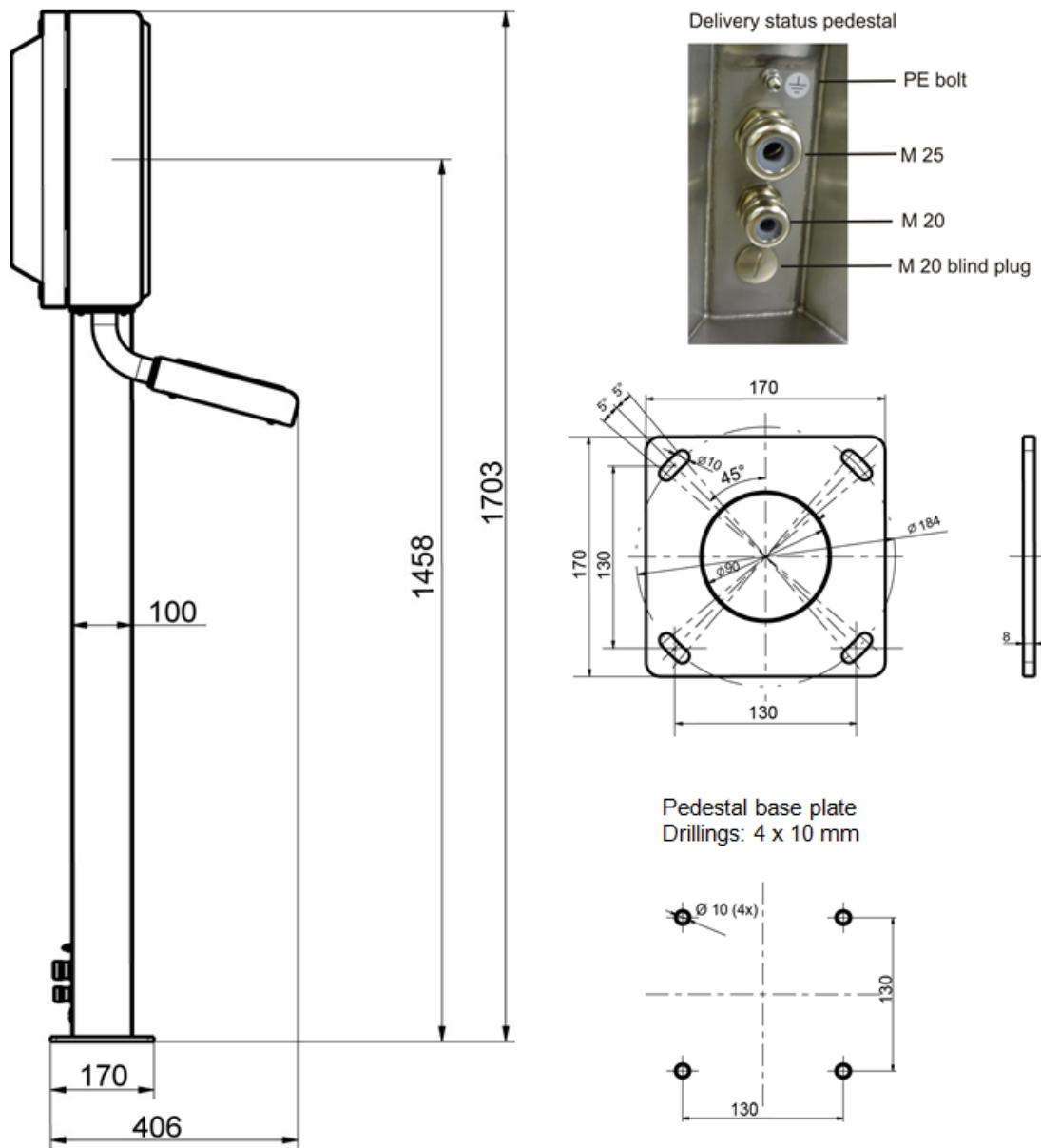

**Note!**

On positioning VisuNet devices a distance of min. 700 mm swivelling range between housing and behind wall has to be observed for mounting and opening. A distance of min. 100 mm between housing and left wall has to be observed, too. (refer chapter 8.12 )

### 8.10.3 Floor Mount for Stainless Steel Housing AGx

#### Pedestal, fix

Order designation: Pedestal5-1458-fix

Floor mount: not turnable

Material: Stainless steel 1.4301 (304)

Optional on request: Stainless steel 1.4571 (316Ti) / 1.4404 (316L)

Standard height 1458 mm to center screen

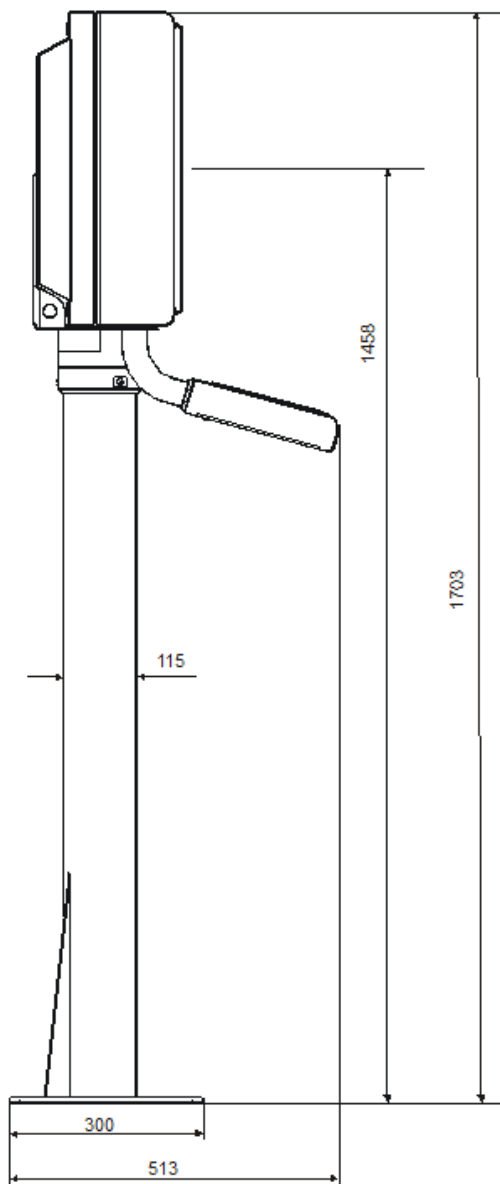

Delivery status pedestal

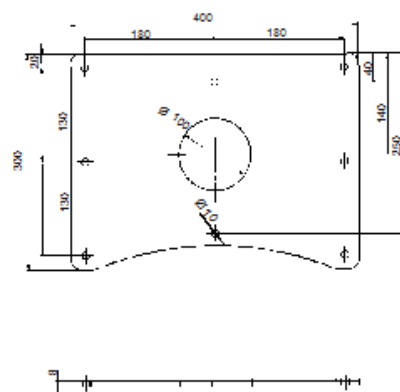
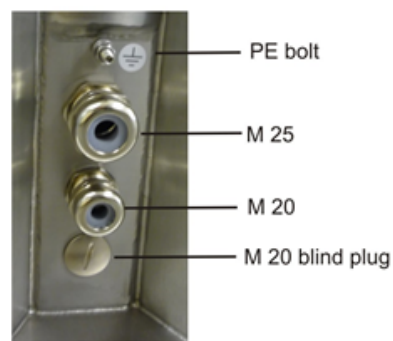

Pedestal base plate  
Drillings: 8 x 10 mm

2015-01



**Note!**

On positioning VisuNet devices a distance of min. 350 mm swivelling range between housing and left wall has to be observed. (refer chapter 8.12 )

**Pedestal, turnable**

Order designation: Pedestal5-1458-turn

Floor mount: turnable

Material: Stainless steel 1.4301 (304)

Optional on request: Stainless steel 1.4571 (316Ti) / 1.4404 (316L)

Eg.: zzzz=1542 mm, ceiling to center screen if ceiling height is 3000 mm

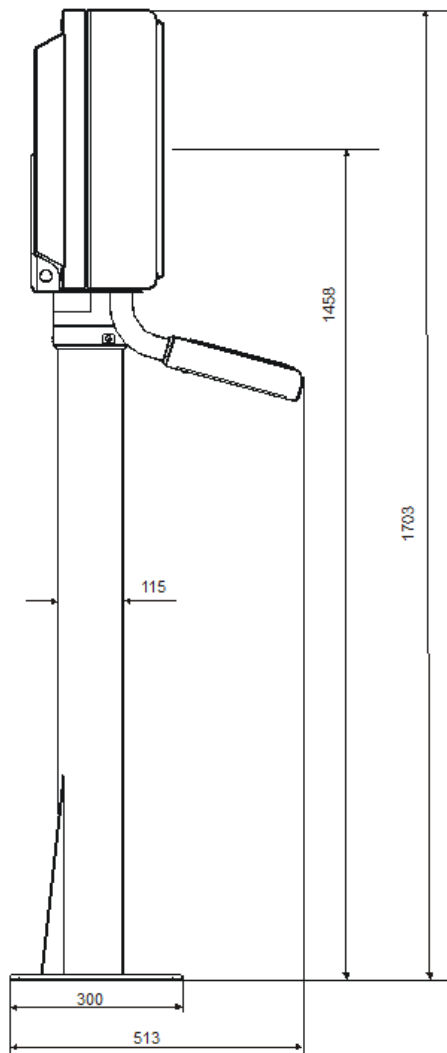

Delivery status pedestal

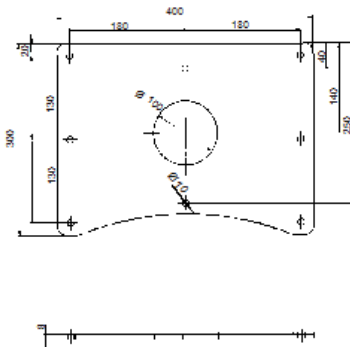
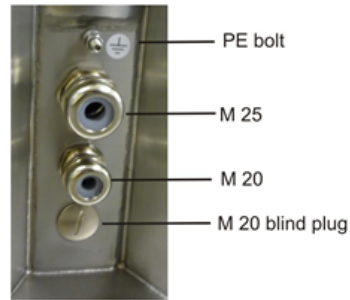

Pedestal base plate  
Drillings: 8 x 10 mm





**Note!**

On positioning VisuNet devices a distance of min. 350 mm swivelling range between housing and left wall has to be observed. (refer chapter 8.12)

**Pedestal, tilt**

Order designation: Pedestal5-1458-tilt

Floor mount: tiltable

Material: Stainless steel 1.4301 (304)

Optional on request: Stainless steel 1.4571 (316Ti) / 1.4404 (316L)

E.g.: zzzz=1542 mm, ceiling to center screen if ceiling height is 3000 mm

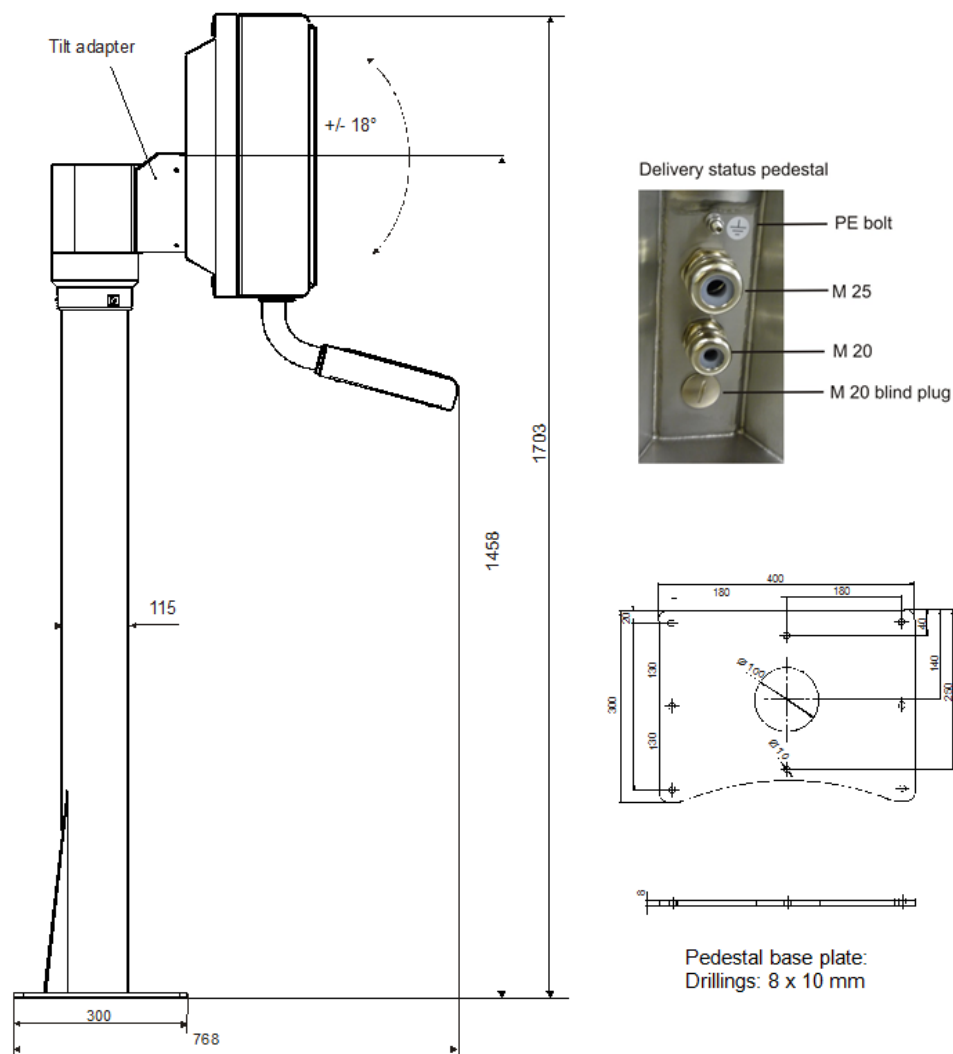

2015-01



**Note!**

On positioning VisuNet devices a distance of min. 350 mm swivelling range between housing and left wall has to be observed. (refer chapter 8.12 )

**Pedestal, turnable and tiltable**

Order designation: Pedestal5-1458-turn-tilt

Floor mount: turnable and tiltable

Material: Stainless steel 1.4301 (304)

Optional on request: Stainless steel 1.4571 (316Ti) / 1.4404 (316L)

E.g.: zzzz=1542 mm, ceiling to center screen if ceiling height is 3000 mm

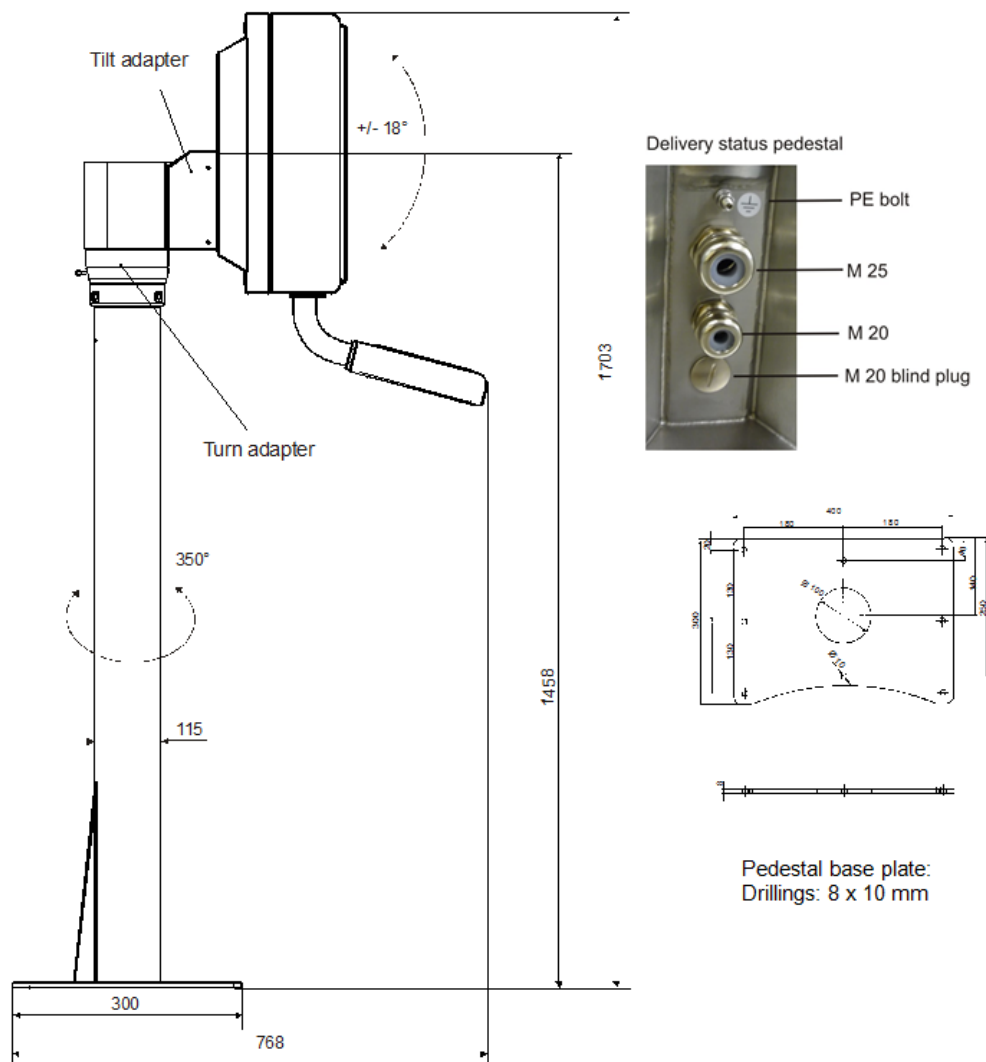



**Note!**

On positioning VisuNet devices a distance of min. 350 mm swivelling range between housing and left wall has to be observed. (refer chapter 8.12 )

**Table Housing**

Order designation: Pedestal5-0528-fix-Y

Pedestal fix

Material: Stainless steel 1.4301 (304)

Optional on request: Stainless steel 1.4571 (316Ti) / 1.4404 (316L)

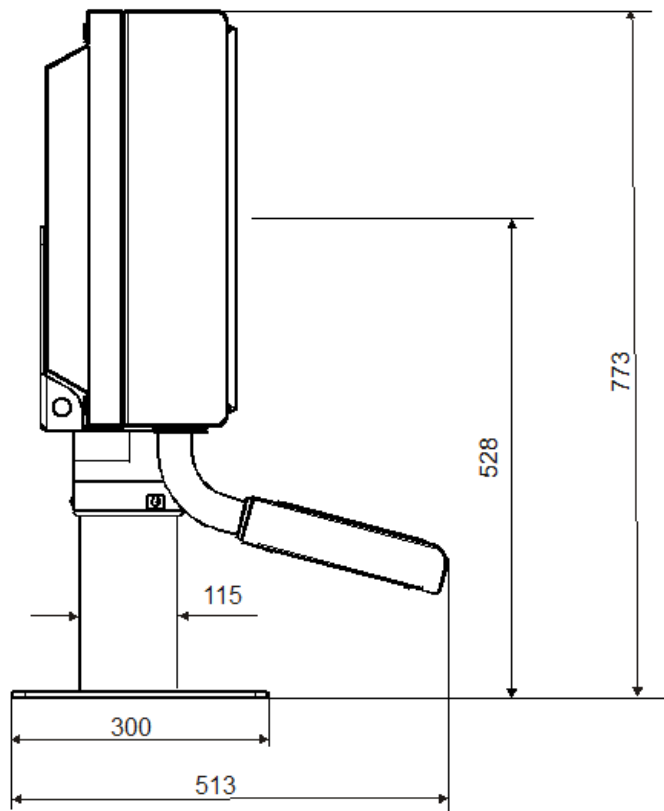

Delivery status

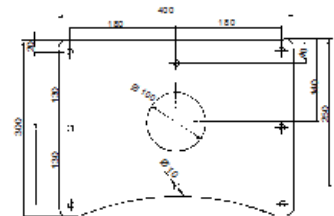
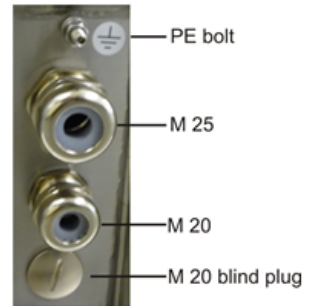

Pedestal base plate:  
Drillings: 8 x 10 mm



**Note!**

On positioning VisuNet devices a distance of min. 350 mm swivelling range between housing and left wall has to be observed. (refer chapter 8.12 )

## Wall Mount

Mounting wall bracket to the wall:

Dimensions:



**12 x M8**

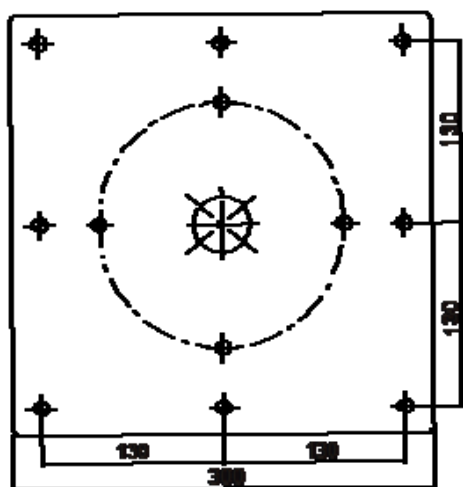

Possibilities of connection by cable glands:

- 1 x M16
- 1 x M20
- 1 x PE bolt

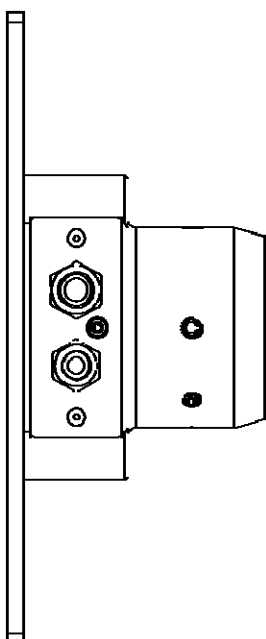

**Wall Mount, fix**

Order designation: Support-Arm5-350-350-fix

Wall mount: not turnable, stainless steel 1.4301 (304)

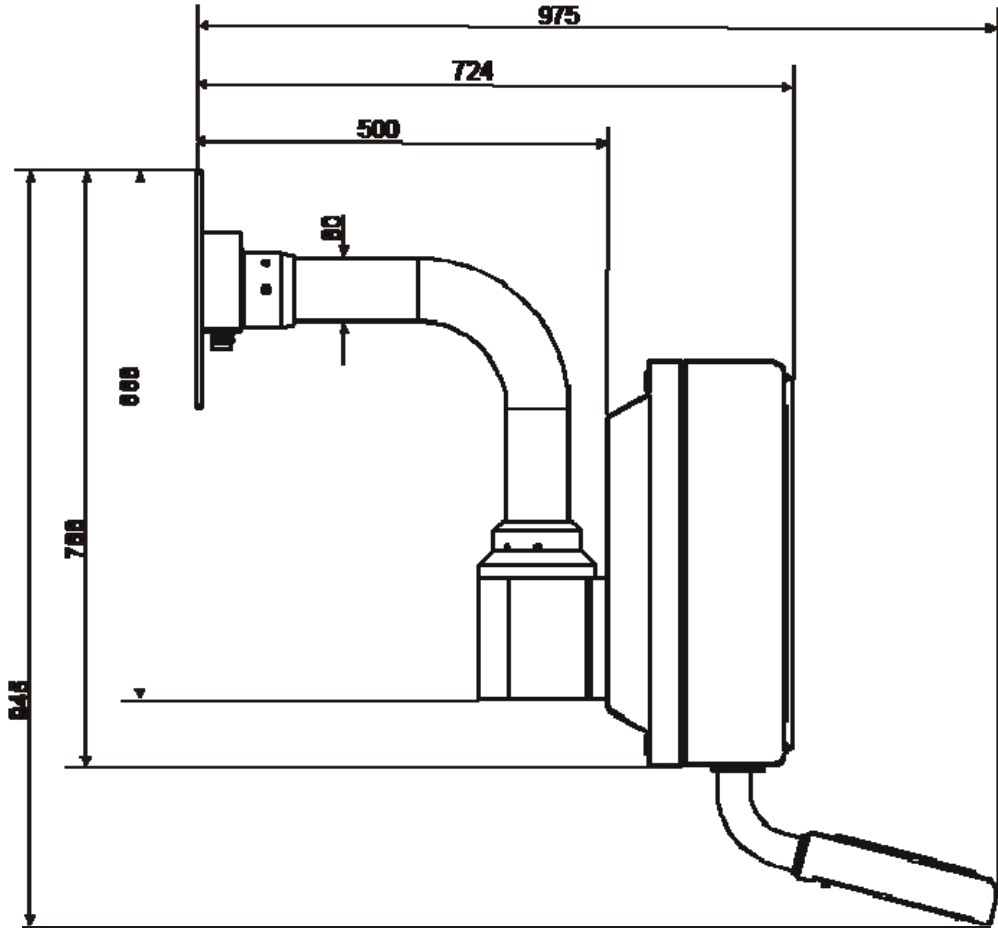

**Note!**

On positioning VisuNet devices a distance of min. 350 mm swivelling range between housing and left wall has to be observed. (refer chapter 8.12 )

### Wall Mount, turnable

Order designation: Support-Arm5-350-350-turn

Wall mount: turnable, stainless steel 1.4301 (304)

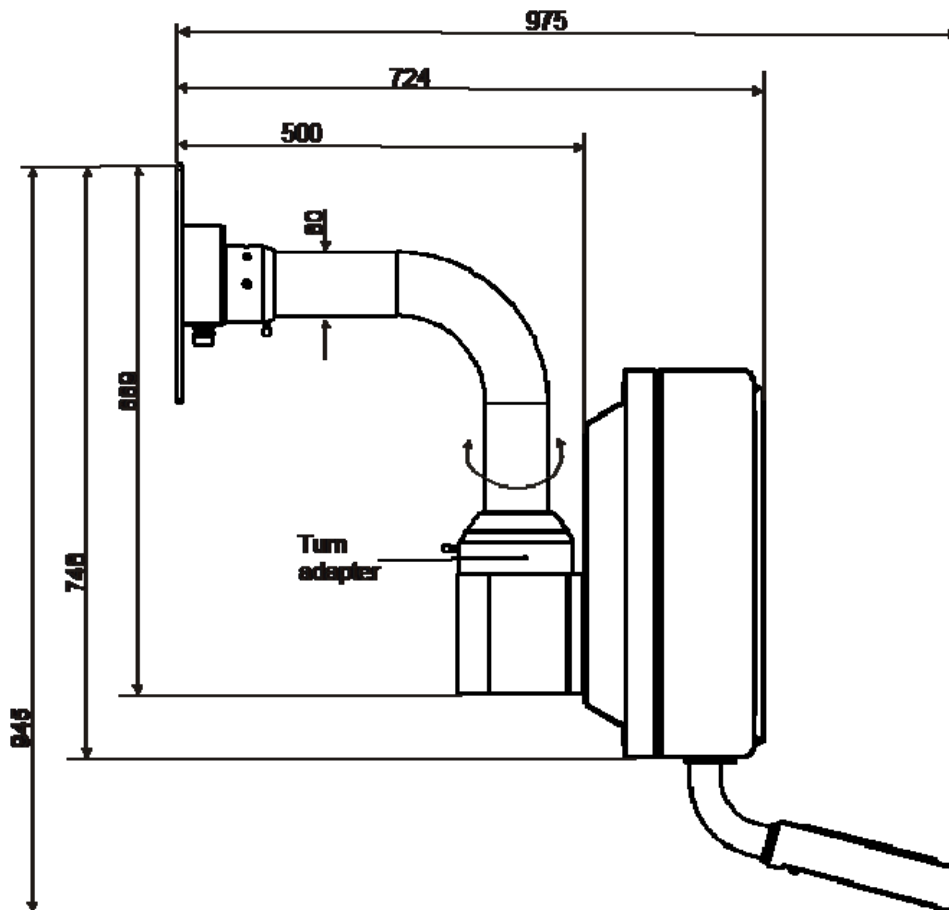

	Swivelling angle
Case AG1 without keyboard	320°
Case AG1 with keyboard	260°

**Note!**

On positioning VisuNet devices a distance of min. 350 mm swivelling range between housing and left wall has to be observed. (refer chapter 8.12)



**Wall Mount, tiltable**

Order designation: Support-Arm5-350-350-tilt

Wall mount: tiltable, stainless steel 1.4301 (304)

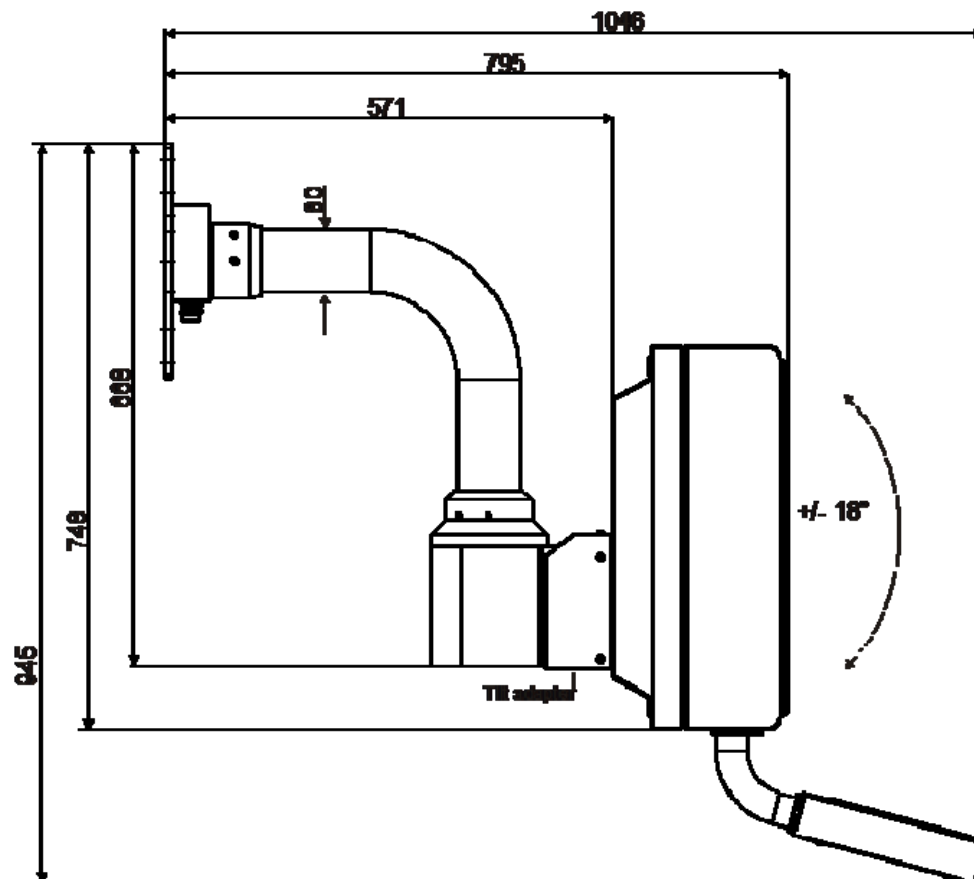

**Note!**

On positioning VisuNet devices a distance of min. 350 mm swivelling range between housing and left wall has to be observed. (refer chapter 8.12 )

### Wall Mount, turnable and tiltable

Order designation: Support-Arm5-350-350-turn-tilt

Wall mount: turnable and tiltable, stainless steel 1.4301 (304)

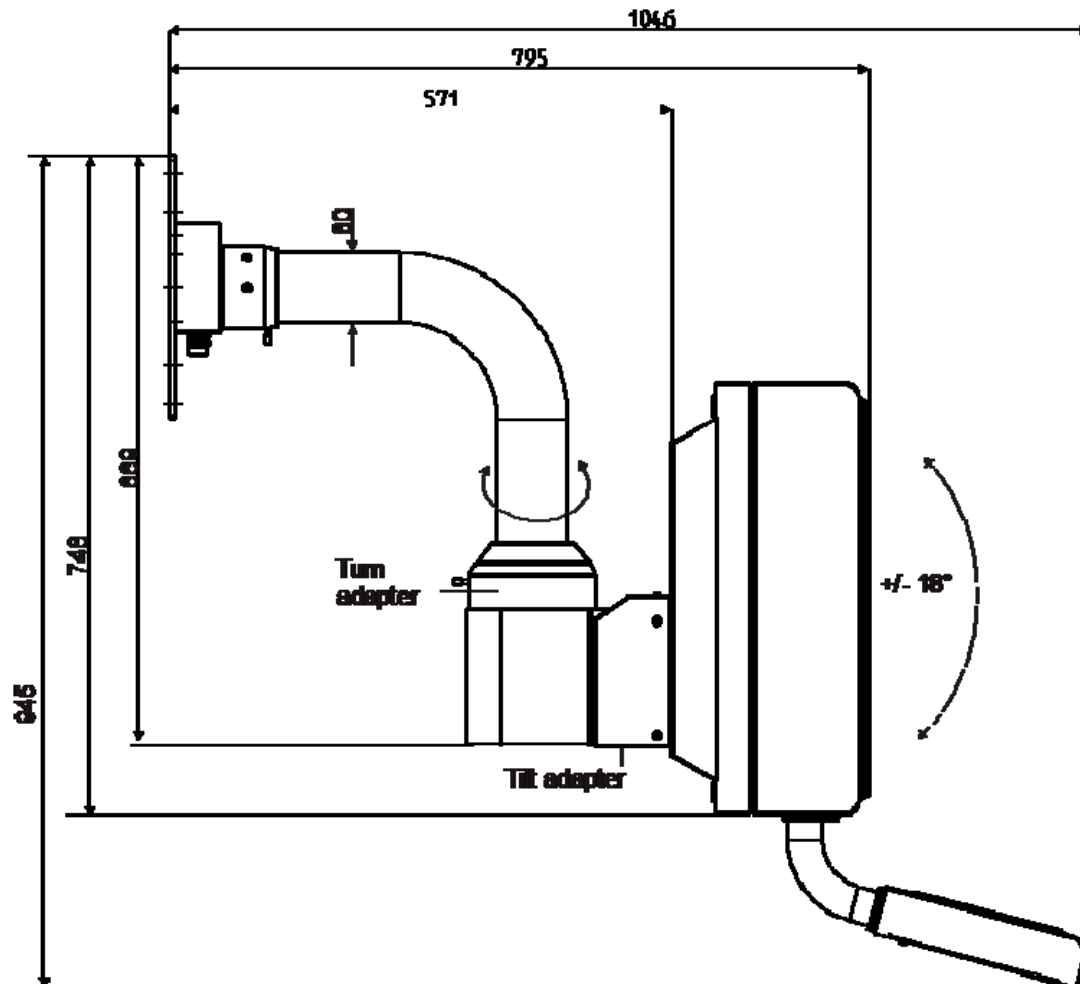

	Swivelling angle
Case AG1 without keyboard (Case justified horizontal)	295°
Case AG1 with keyboard (Case justified horizontal)	250°



**Note!**

On positioning VisuNet devices a distance of min. 350 mm swivelling range between housing and left wall has to be observed. (refer chapter 8.12)



### Ceiling Mount

Drilling pattern for mounting ceiling bracket



12 x M8

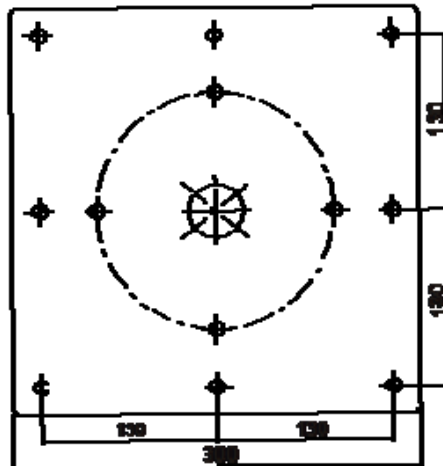

Possibilities of connection by cable glands:

- 1 x M16
- 1 x M20
- 1 x PE bolt

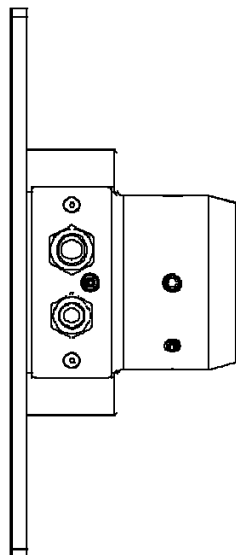

### Ceiling, fix

Order designation: Ceiling5-zzzz-fix

Ceiling not turnable

Material: Stainless steel 1.4301 (304)

Optional on request: Stainless steel 1.4571 (316Ti) / 1.4404 (316L)

Ceiling height - 1458 = ZZZZ

(Example: Ceiling height 3m: 3000-1458 = 1542 = ZZZZ Ceiling5-1542-fix)

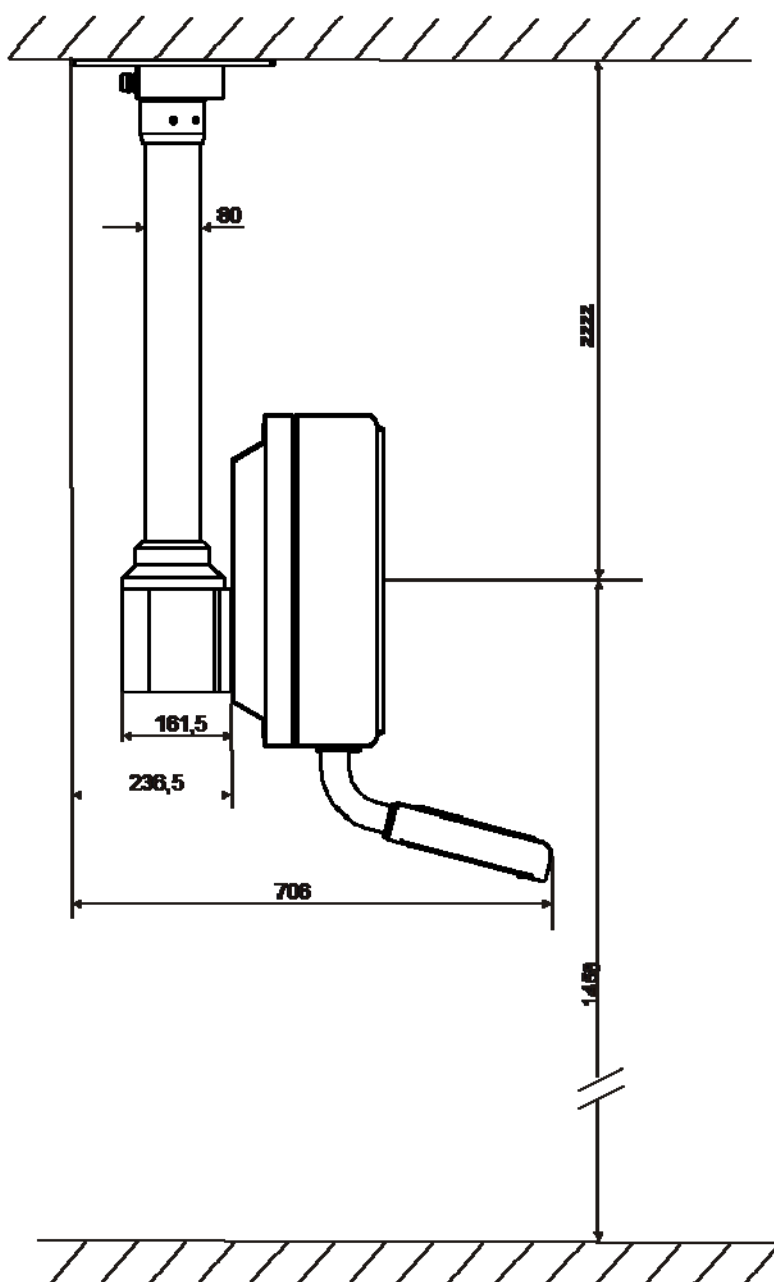

2015-01



**Note!**

On positioning VisuNet devices a distance of min. 350 mm swivelling range between housing and left wall has to be observed. (refer chapter 8.12 )

**Ceiling, turnable**

Order designation: Ceiling5-zzzz-turn

Ceiling turnable ( +/- 175°)

Material: Stainless steel 1.4301 (304)

Optional on request: Stainless steel 1.4571 (316Ti) / 1.4404 (316L)

Ceiling height – 1458 = zzzz

(Example: Ceiling height 3m: 3000-1458 = zzzz Ceiling5-1542-turn)

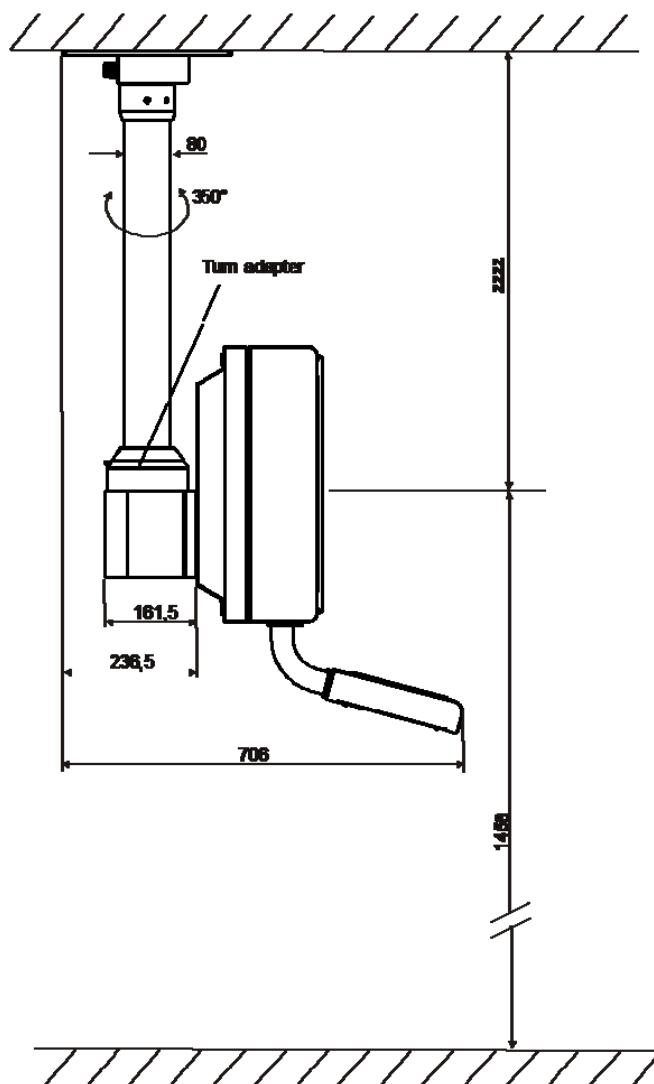

2015-01



**Note!**

On positioning VisuNet devices a distance of min. 350 mm swivelling range between housing and left wall has to be observed. (refer chapter 8.12)

**Ceiling, tiltable**

Order designation: Ceiling5-zzzz-tilt

Ceiling tiltable

Material: Stainless steel 1.4301 (304)

Optional on request: Stainless steel 1.4571 (316Ti) / 1.4404 (316L)

E.g.: ceiling height – 1458 = zzzz

( e.g. ceiling height 3 m: 3000 – 1458 = 1542 = zzzz Ceiling5-1542-tilt)

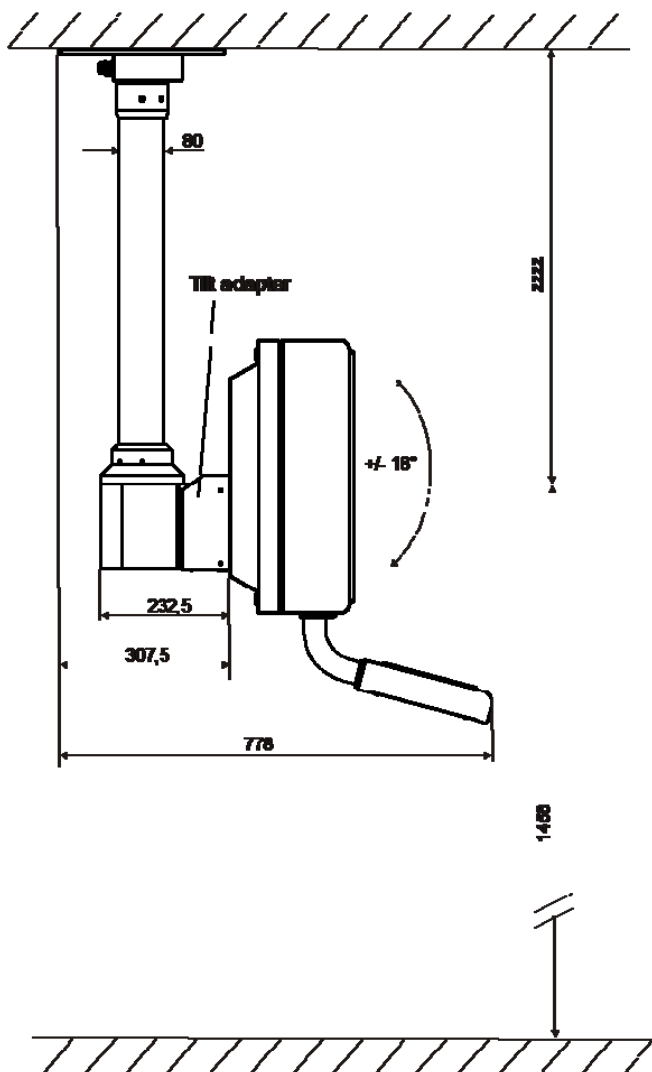



**Note!**

On positioning VisuNet devices a distance of min. 350 mm swivelling range between housing and left wall has to be observed. (refer chapter 8.12)

**Ceiling, turnable and tiltable**

Order designation: Ceiling5-zzzz-turn-tilt

Ceiling turnable and tiltable

Material: Stainless steel 1.4301 (304)

Optional on request: Stainless steel 1.4571 (316Ti) / 1.4404 (316L)

E.g.: ceiling height – 1458 = zzzz

(e.g. ceiling height 3 m: 3000 – 1458 = 1542 = zzzz Ceiling5-1542-turn-tilt)

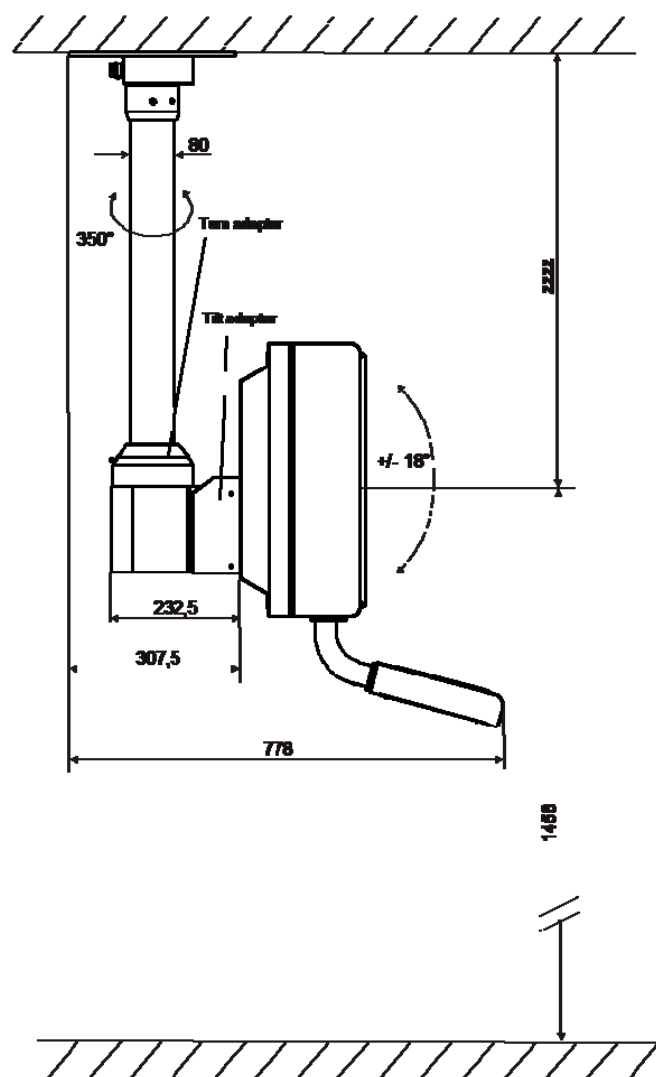

2015-01



**Note!**

On positioning VisuNet devices a distance of min. 350 mm swivelling range between housing and left wall has to be observed. (refer chapter 8.12 )

## 9 Accessories VisuNet RM and VisuNet PC

### 9.1 Barcode Reader

The VisuNet RM/PC can operate an intrinsically safe barcode reader at its intrinsically safe TTY interface. The following products can be used:

PSCAN-M (radio barcode reader) with PSCAN-B (base station)



PSCAN-D (barcode reader) with 5m helix cable



Please also refer to the barcode reader operating instructions if one of these intrinsically safe barcode readers is connected. The terminal assignment of the VisuNet RM/PC is shown in section 6.

### 9.1.1 Holder for Barcode Reader

(with the order of a barcode reader (interface option -S / -A) the holder for the barcode reader is contained in the order)

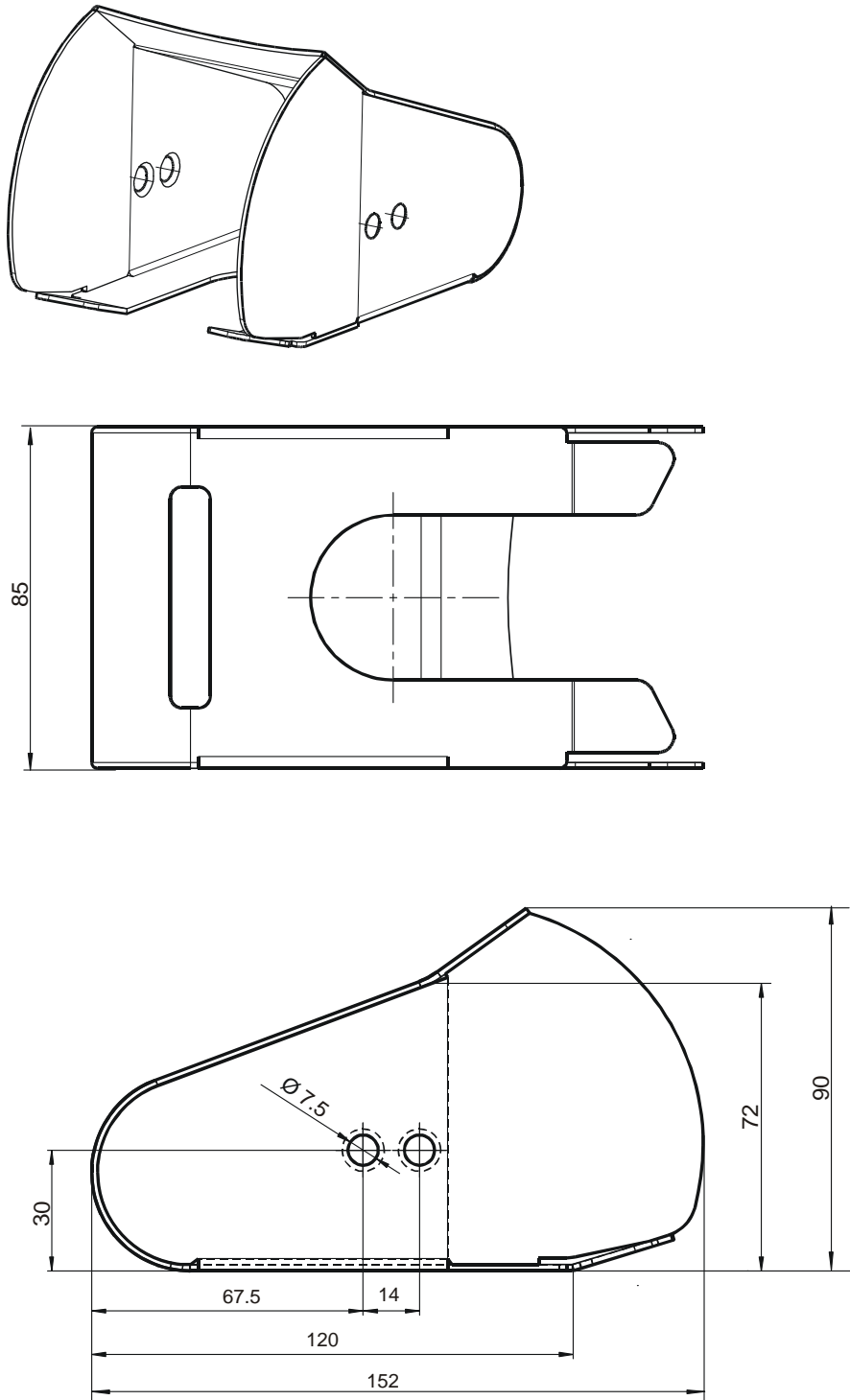

All dimensions in mm



### Holder for the Barcode Reader at the Case AG1

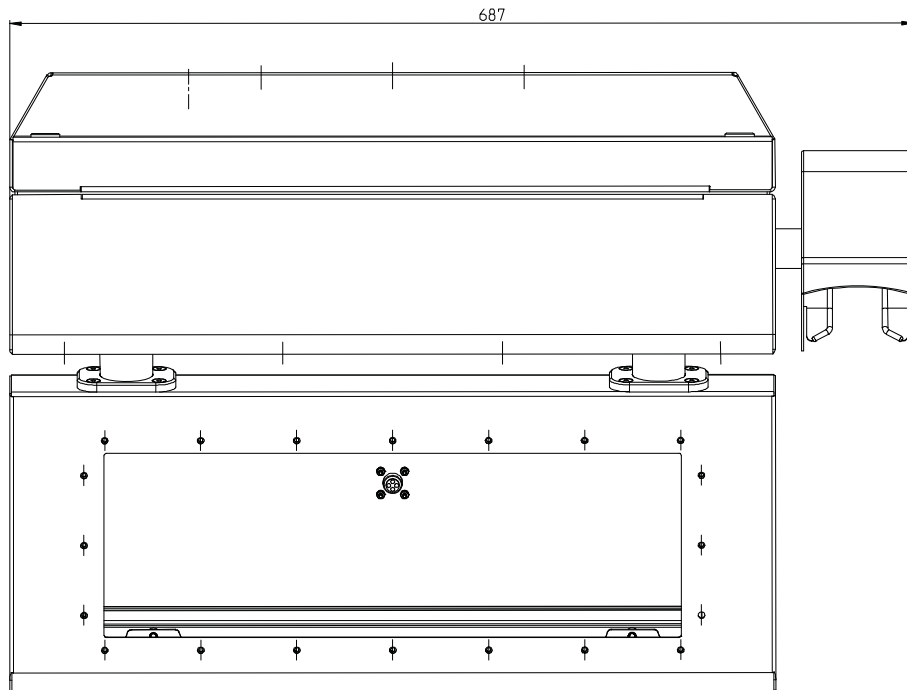
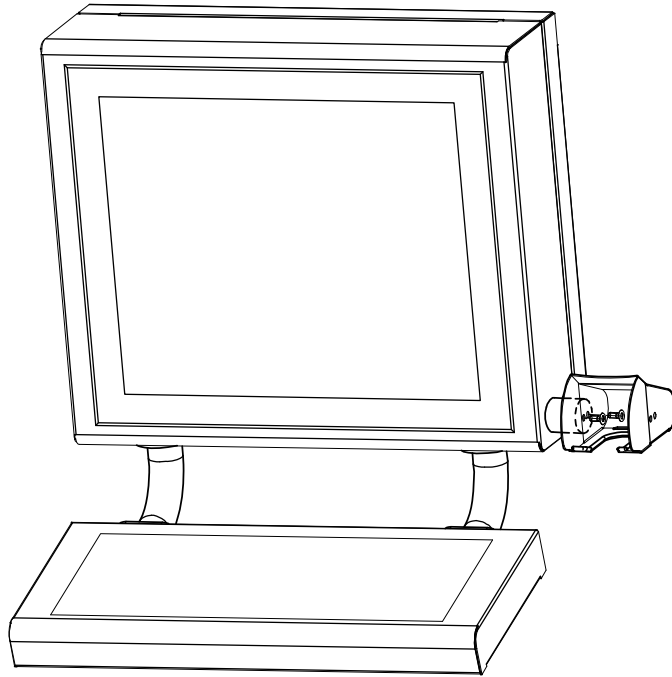

2015-01

## Mounting the Barcode Reader to Case AG1

1. Screw the two enclosed countersunk head screws tight to the spacer on the AG1 case with an Allen key.

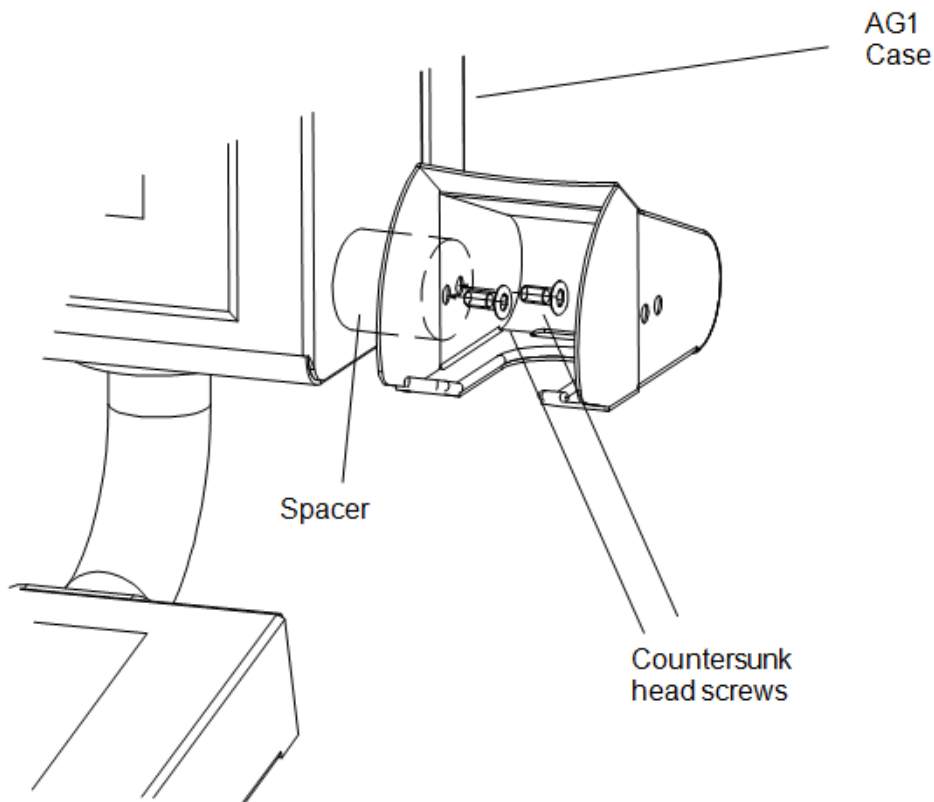

## Supplementary Upgrade of the VisuNet in AG1 Housing with the Barcode Readers

1. Upgrade the socket for the barcode reader
2. Upgrade the holder for the barcode reader on the AG1 housing
3. Connect the cable between the socket of the barcode reader and the interface of the VisuNet

### Upgrade of the Socket for the Barcode Reader

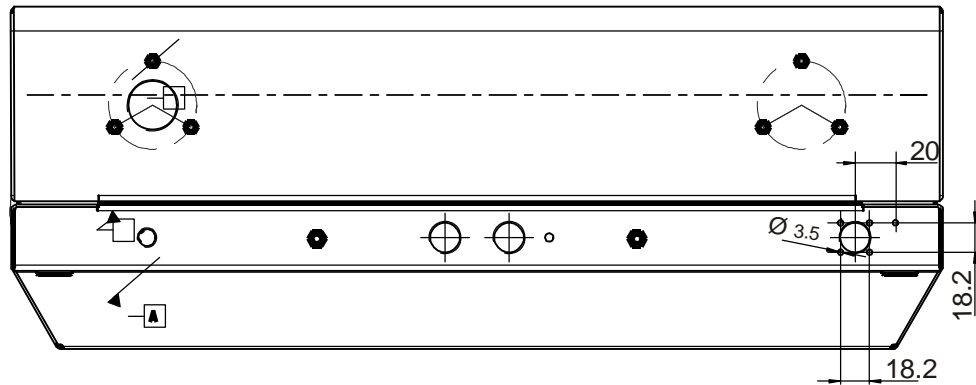

1. Drill-hole M20x1.5 exists in AG1 housing
2. Set 5 drill-holes Ø 3.5, four for the socket of the barcode reader and one for the PA.

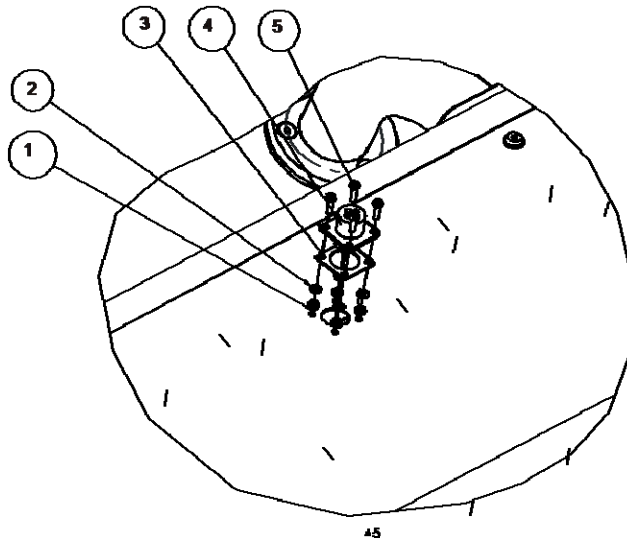

1. Hex nut
2. Lock-washer
3. Gasket
4. Socket for barcode reader
5. Rounded head screw

3. Mount the socket for the barcode reader as described in the mechanical drawing.

## Upgrade the Holder for Barcode Reader on the AG1 Housing

1. Set 2 drill-holes for the spacer on the AG1 housing

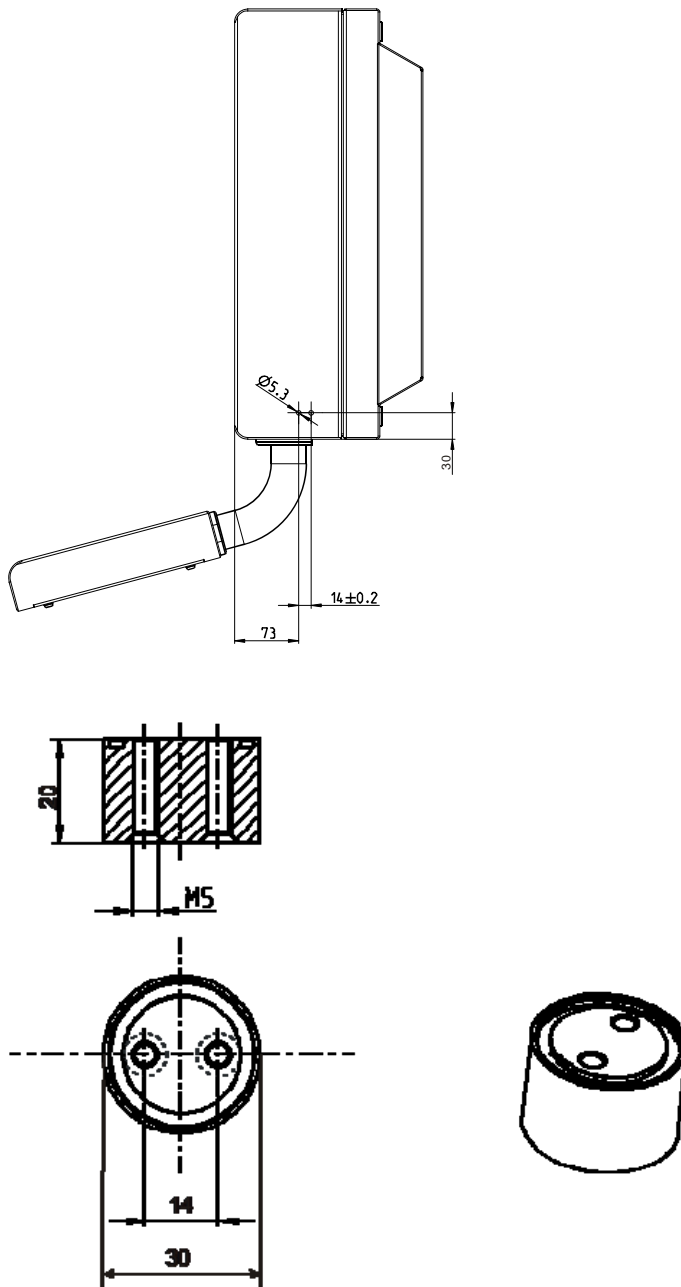

### Mounting the Spacer on the Holder for Barcode Reader

1. Tighten the both countersunk head screws with an allen key on the spacer.

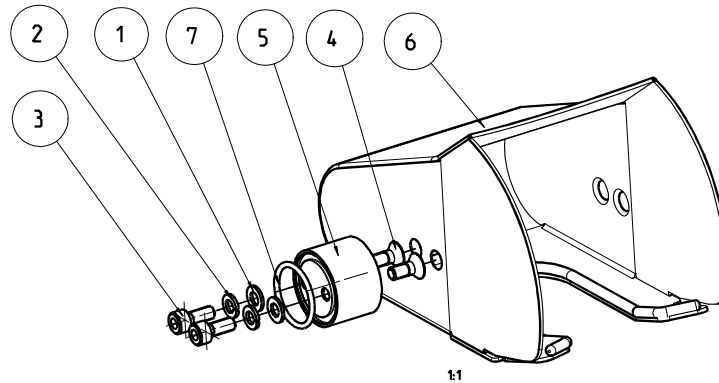

1. Washer
2. Lock-washer
3. Cylinder head screw with allen screw
4. Countersunk head screw
5. Spacer
6. Holder for barcode reader
7. O-ring seal

### Mounting the Holder for Barcode Reader with the Spacer on the AG1 Housing

1. Put the lock-washer (2) and the washer (1) on the cylinder head screw with allen screw (3).
2. Put the cylinder head screws (3) through the drillings on the AG1 housing.
3. Place the O-ring seal into the spacer.
4. Tighten the cylinder head screw (3) with an allen key on the AG1 housing.

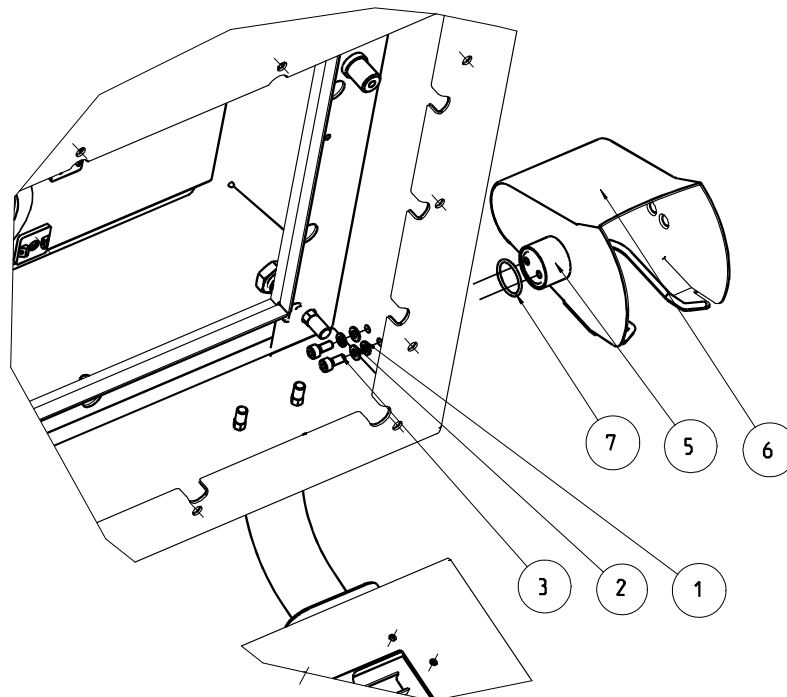

2015-01

## 9.2 BOX-A10 (Ethernet RJ45 1 Off Patch Field Element)

It offers a 1 off Ethernet RJ 45 socket for DIN rail mount. The socket is crimpable to the end of the Ethernet field cable. It is the junction element between the fix installed Ethernet field cable (Cat.6e or Cat.7) and a patch cable to a switch, router or PC.

It is supplied as an accessory for the VisuNet RM/PC. (see chap. 13.1)

### Box-A10

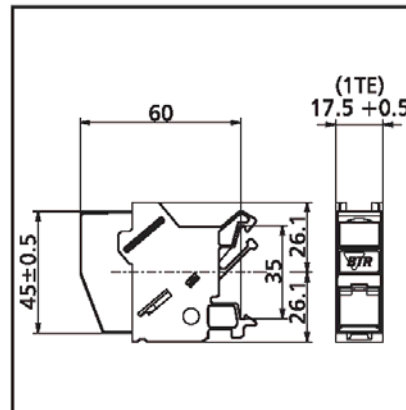

## 9.2.1 Connection Instructions

### Preparation of the BOX-A10 for Installation on a DIN Rail (35 mm)

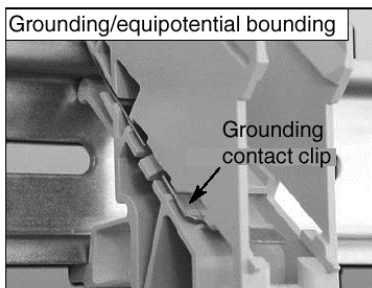

The modules are grounded directly on the rail via the ground contact spring. This spring is connected by a ground terminal to the equipotential bonding. The rail must be electrically conductive

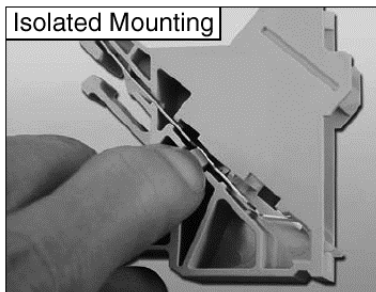

If the module is not supposed to be grounded, press the locking latch on the housing down and remove the ground contact spring.

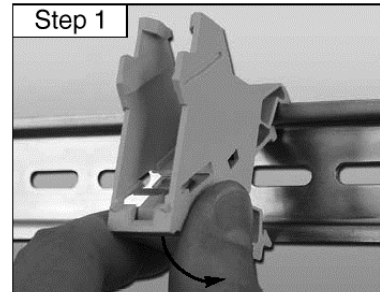

Then snap the lower housing part of the E-DAT REG module onto the rail

### Preparation of the DATL-CAT71 Ethernet Cable

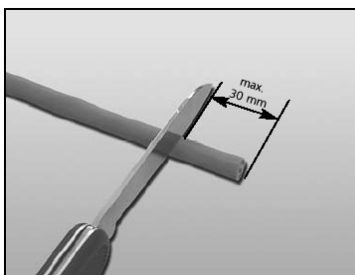

Remove about 25 mm (max. 30 mm) of the plastic sheath.

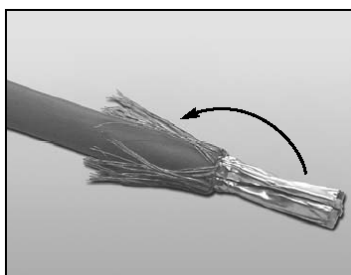

Fold back the braided shield...

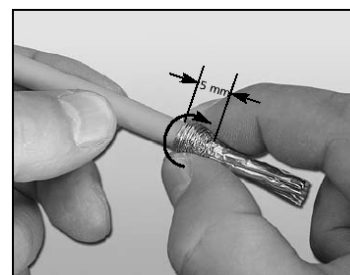

...and wrap it around the plastic sheath.

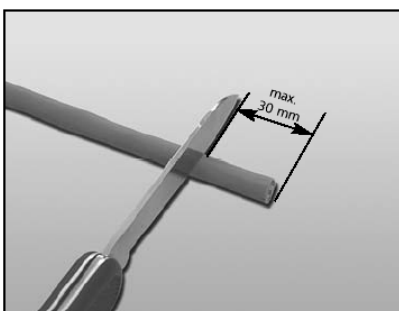

Glue in the shield film for the wire pairs and remove.

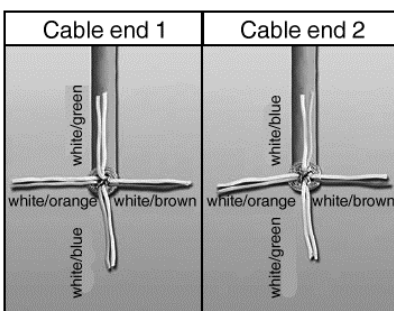

Separate the pairs of wires according to how they exit at the cable ends...

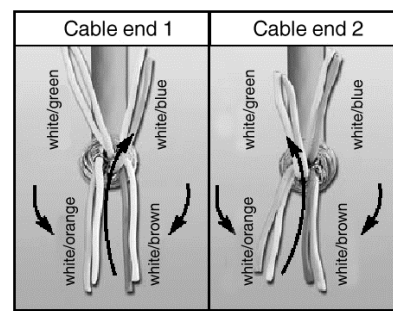

..and arrange them as shown in the photo to facilitate wire insertion into the loader later.

### Cable Termination

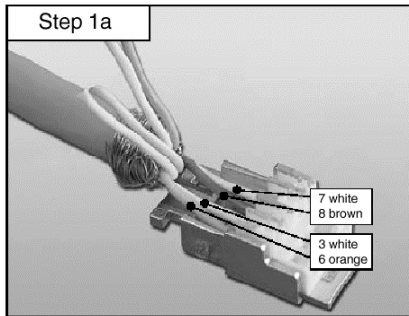

Insert the white/brown and white/orange pairs of wires into the lower part of the loader...

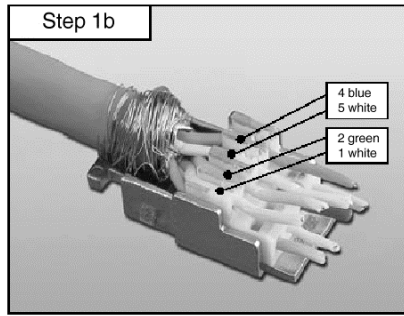

...and the blue/white and green/white pairs of wires into the upper part.

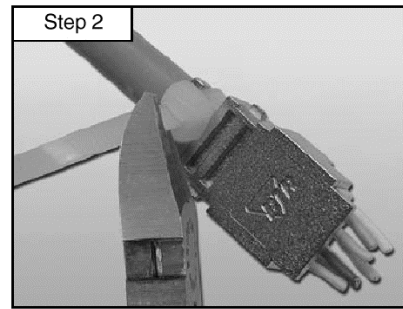

Fit a cable tie as strain relief and cut off the excess length.

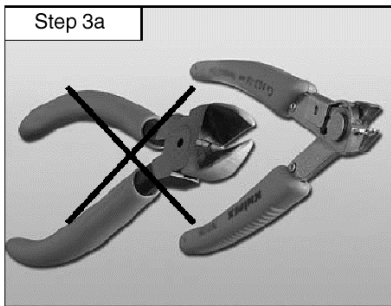

Use a wire cutter of appropriate size to remove the wire ends...

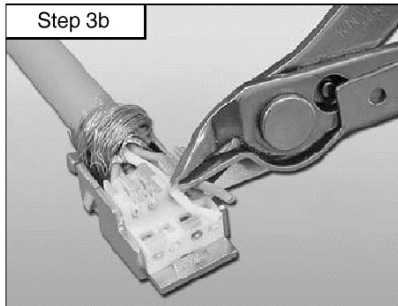

...and cut them flush.

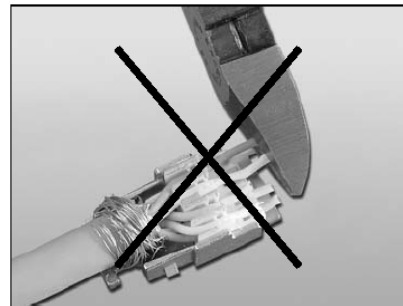

The wires cannot be cut properly flush with an unsuitable wire cutter. This will cause problems when the two housing parts are assembled.

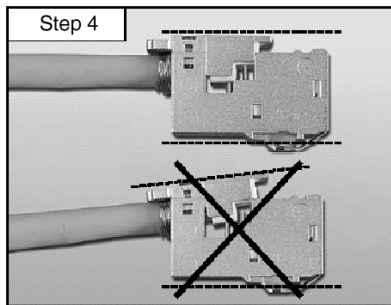

Assemble the housing by positioning the loader straight on the lower housing part.

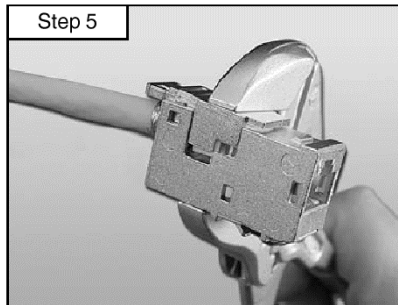

Apply pliers in the middle of the module and squeeze them until the housing is closed.

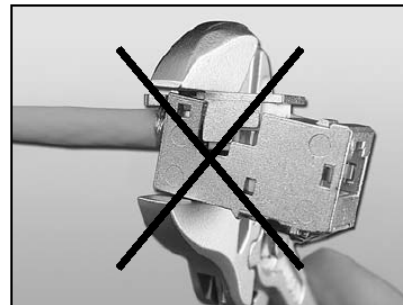

If the pliers are applied too far back, the loader may be displaced, damaging the ID connectors inside the module.



### Installation of the Modules

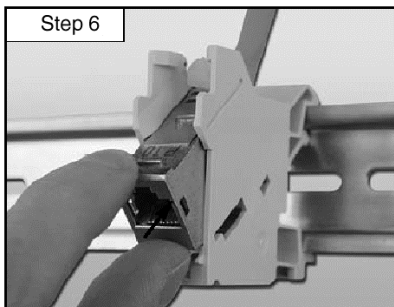

Insert the assembled 8(8) module into the lower part of the REG housing.

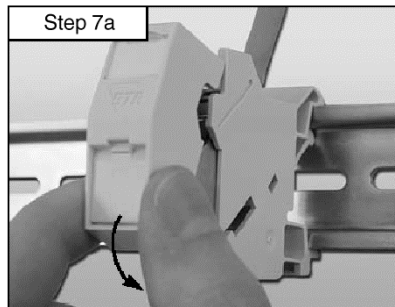

Attach the housing cover to the top of the lower section and click it downwards into place.

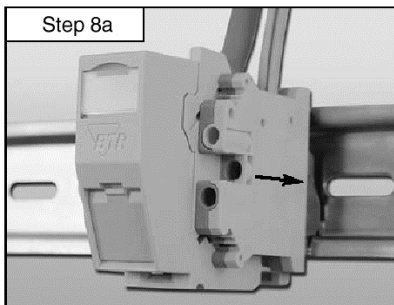
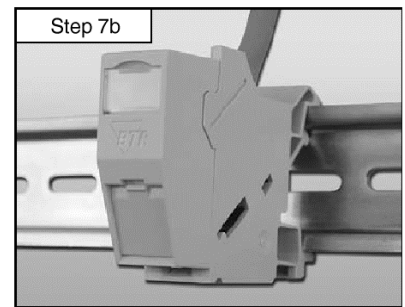

The rail must be connected by a ground terminal to the ground electrode, to ensure proper equipotential bonding of the modules.

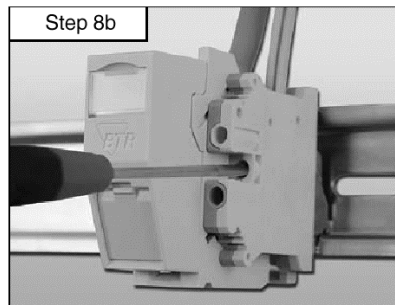

Simply fit this terminal onto the rail, screw it tight and connect it to the equipotential bonding.

### Disassembly of the Individual Components

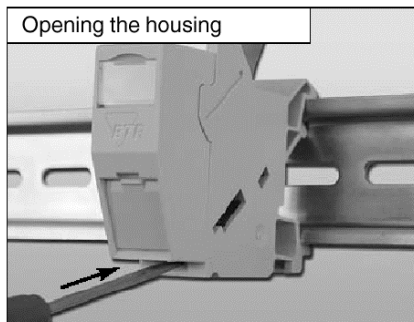

Loosen the upper housing part with a screwdriver and remove.

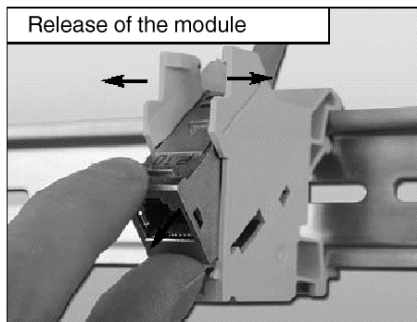

Press the housing walls gently outwards and take out the module.

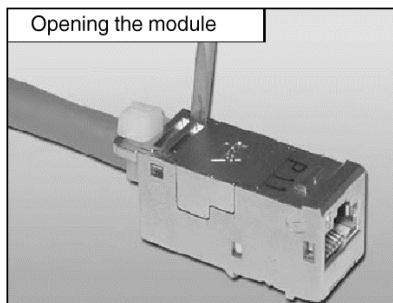

Lever out the loader with the screwdriver...

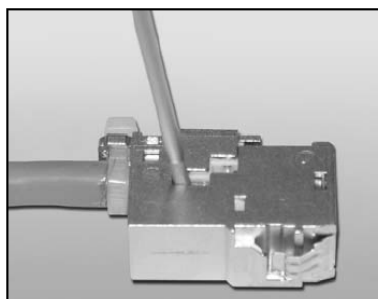

... and carefully separate the two parts of the housing.

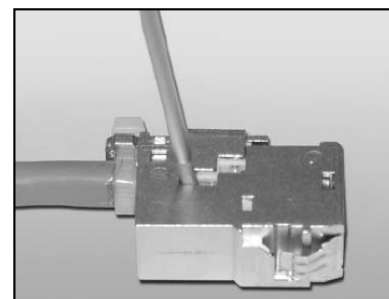

### 9.2.2 Technical Data Box A10

Plug socket BOX A10

View of spring-loaded contacts

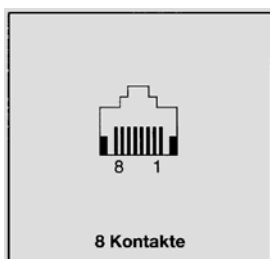

### Mechanical Characteristics

Wire connection:

Insulation piercing connecting device BTR-IDC: Conductor 0.4 – 0.65 mm

AWG 26 – 22 insulation 0.7 – 1.4 mm (1.6 mm)

AWG 26/7 stranded wire conductor with 7 Cu strands, uninsulated

Can be reused for AWG 22, AWG 23 and AWG 24, providing an identical or larger cross-section is selected.

### 9.2.3 Connection Instructions VisuNet RM/PC

(10/100 BASE TX Ethernet cable: DATL-CAT71-8-2, recommendation for cable see chap.10.3.1)

BOX A10

Box-A10-Kat.7-RJ45-Mini-Patch

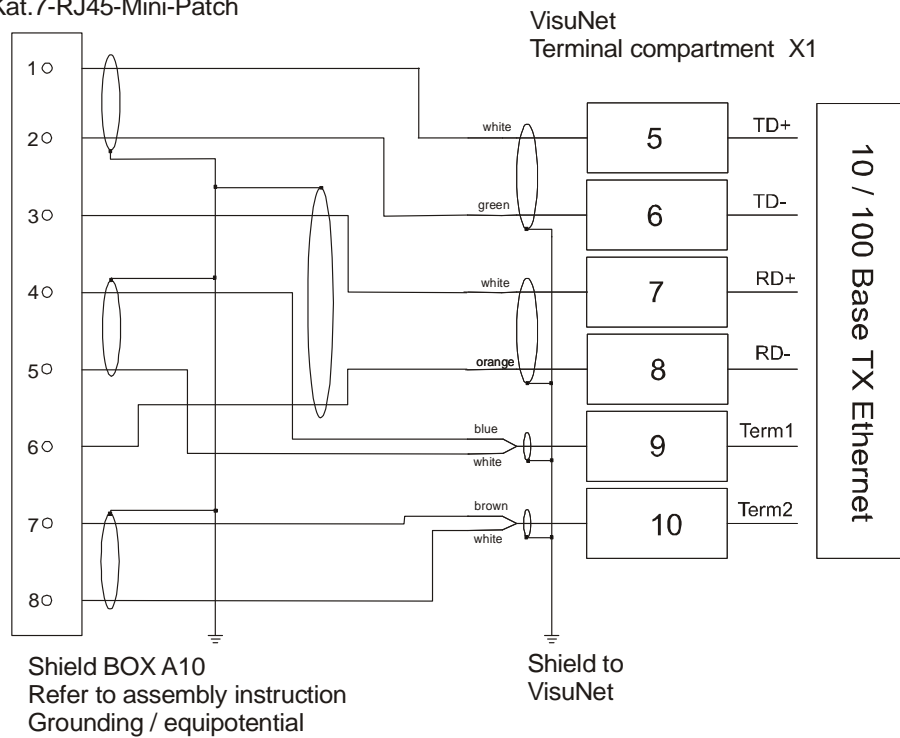

Cable:  
DATL-CAT71-8-2

### Order when Connecting



**Note!**

When connecting please check that the pairs of wires are twisted till near the clamp.

Example:



### 9.3 PC Keyboard Intrinsically Safe (Components Optional)

The intrinsically safe keyboards integrate different mouse systems. The dimensions are the same for all versions. The keyboards are designed to be installed in a housing.

Please also refer to the TASTEX EXTA2 operating instructions if an EXTA2 keyboard is connected.

	Assignment	Color coding	Terminal compartment X2 (Ex ib) Core assignment
Keyboard cable	+5V	green	X2.1
	D+	brown	X2.2
	D-	grey	X2.3
	GND	yellow	X2.4
Mouse cabel	+5V	red	X2.5
	D+	white	X2.6
	D-	pink	X2.7
	GND	blue	X2.8

## 10 Installation VisuNet RM and VisuNet PC

### 10.1 General Instructions and Explosion Protection Requirements

Cables are only allowed to be connected when de-energized. Make sure that all terminal compartments are tightly sealed in accordance with regulations prior to starting up the equipment.

All cable glands must be screwed tight and checked to ensure that they are securely in position.

The minimum clearances in air and creepage distances in the vicinity of the terminals must be maintained; they must not be shortened by stripping the wires too far. (isolated wire end sleeve with  $l_{max}=8mm$ ).

- The cables in the vicinity of terminal compartments (Ex e) must be fixed-mounted.
- The cables in the vicinity of the intrinsically safe terminal compartment (Ex ib) can be flexibly laid.

### 10.2 External Equipotential Bonding

Explosion-protected electrical equipment in a metal case must be provided with external equipotential bonding, which must be connected to the equipotential bonding of the system over the shortest possible distance (cross section: min.  $4mm^2$ ).

### 10.3 Cable Types and Maximum Cable Lengths



**Warning!**

For wiring of interfaces with the type of protection “e” increased safety the standard EN 60079-14 has to be considered!

#### 10.3.1 Ethernet 100BASE-TX (Ex e)

We recommend using a high-quality cable to assure a minimum of errors during Ethernet data transmission. A large core cross-section and excellent shielding increase the permissible cable length and reduce transmission errors, leading to a higher transmission speed.

The table below provides a rough guide to the line lengths that can be achieved with different cable qualities.

Short name	Description	Cable length
<b>Cat. 7</b>	<b>4 x 2 x AWG22 S/FTP (600 MHz) Paired, twisted and shielded</b>	<b>90 m</b>
Cat. 6e	4 x 2 x AWG22 or AWG23 S/STP or S/FTP (500 MHz)	80 m
Cat. 6	4 x 2 x AWG24 S/UTP (250 MHz)	60 to 70 m

We recommend using a Cat. 7 cable because it offers the best results, especially in an industrial environment.

In addition to the cable quality, transmission reliability can be negatively affected by four other factors:

- EMC, e.g. interference from current leads laid parallel
- Quality of the connectors, e.g. high loss values
- Cable routing, e.g. sharp bends
- Number of insertion points and cable transitions

### Troubleshooting the Ethernet Connection

If you cannot establish an Ethernet connection	
VisuNet PC	VisuNet RM
Link LED	- Check the IP address (bottom right) There is no link if the IP address is 127.0.0.1
<b>Link on:</b> A physical connection exists between the switch, the server or PC and VisuNet	
<b>Link off:</b> No Ethernet connection Remedy: Check the wiring <ul style="list-style-type: none"> <li>■ Make sure the wiring in the Ex e terminal compartment (X1) corresponds to the information in the manual (refer to section 6.1)</li> <li>■ Make sure the switch and the server or PC are wired correctly. A crossover cable is required for a direct connection.</li> </ul>	

If the Link LED is on but you cannot establish an Ethernet connection	
VisuNet PC	VisuNet RM
Send a ping: Ping a suitable partner with START / RUN / CMD Ping 192.xxx.xxx.xxx	Send a ping: Start the ping tool ("Ping Host") in configuration mode
<b>Ping works</b>	
If a connection is established between the host and VisuNet but the ping does not work	
<b>VisuNet PC</b> Check the settings under START / RUN CMD / IPCONFIG and change the network settings if necessary.	<b>VisuNet RM</b> Check the settings in Configuration Mode / Settings / TCP/IP. You should have set: Subnet mask, IP address, default gateway
<ul style="list-style-type: none"> <li>■ Check whether the ping is blocked by the partner's firewall (default setting with XPP/SP2)</li> <li>■ Ask the partner to send a ping. VisuNet RM is programmed so that it always answers</li> <li>■ Repeat the ping</li> </ul>	

2015-01

**If the ping works but you cannot establish an Ethernet connection**

**VisuNet PC and VisuNet RM**

Remedy:  
Check the firewall settings on the host, switch or router

**10.3.2 USB (Ex e)**

Paired data cable for fixed mounting with copper braiding and a cross-section of 0.75 mm<sup>2</sup>, e.g. LiYCY (TP) 2 x 2 x 0.75.

The maximum cable length is 5 m.

**10.3.3 RS 422 (Ex e)**

Paired data cable for fixed mounting with copper braiding and a cross-section of 0.75 mm<sup>2</sup>, e.g. LiYCY (TP) 2 x 2 x 0.75.

The maximum cable length is 1200 m and the maximum baudrate 57600 baud.

**10.3.4 RS 232 (Ex e)**

Paired data cable for fixed mounting with copper braiding and a cross-section of 0.75 mm<sup>2</sup>, (e.g. LiYCY 4 x 0.75).

The maximum cable length is 50 m at a baudrate of 9600 baud.

Cable capacitance < 50pF/m

**10.3.5 RS485 Interface (Ex e)**

Paired data cable for fixed mounting with copper braiding and a cross-section of 0.75 mm<sup>2</sup>, e.g. LiYCY (TP) 2 x 2 x 0.75.

The maximum cable length is 1200 m and the maximum baudrate 57600 baud.

**Warning!**

For wiring of interfaces with the type of protection “e” increased safety the standard EN 60079-14 has to be considered!

**10.3.6 External Keyboard (Ex ib)**

The keyboard is supplied with the already connected cable. See 6.2, for the VisuNet RM/PC.

**10.3.7 Mouse (Ex ib)**

The mouse is supplied with the already connected cable. See 6.2, for the VisuNet RM/PC.

**10.3.8 20 mA TTY-Interface (Ex ib) e.g. Scanner**

This interface is used to connect intrinsically safe apparatus, e.g. input devices such as a barcode reader.

Paired data cable for fixed mounting with copper braid.

0.75 mm<sup>2</sup> cross-section, e.g. LiYCY (TP) 2 x 2 x 0.75.

The maximum cable length is 50 m.



### 10.3.9 VisuNet Power Supply Cable (24V DC)

DC Power supply cable			
Part code:	Order number	Cable length	Information
DATL-A2-2.5-1	205285	up to 80m	
DATL-A2-2.5-1-Flex (flexible cable 2 x 2.5 mm <sup>2</sup> )	205286	up to 80 m	If the VisuNet is ordered in a case AGx and additional with a <u>turnable accessory for mounting</u> a flexible cable must be used!
DATL-A2-4.0N/2.5F-2 (solid cable 2 x 4.0 mm <sup>2</sup> ----- 2.5 m flexible cable 2 x 2.5 mm <sup>2</sup> )	206496	up to 110m	

## 10.4 Shielding of Data Cables

### 10.4.1 Shielding Concept

The purpose of cable shielding is usually to improve the signal quality and reduce interference as well as radiation from electromagnetic fields.

The data cables (RS485, TTY, Ethernet) must be shielded. The shields must be continuously connected and grounded in order to guarantee the necessary interference suppression.

One of the following three techniques should be used:

1. Connect and hard ground both ends of the shield. This method achieves the greatest reduction in electromagnetic interference. There is, however, a risk of current loops with high compensating currents. These currents can lead to safety problems if their values are excessive.
2. Connect and hard ground one end of the shield. This method achieves a reduction in electromagnetic interference while simultaneously preventing the above-mentioned current loops.
3. Provide a hard connection at one end of the shield (VisuNet RM/PC) and capacitive grounding at the other end in the safe area. This method achieves a relatively large reduction in electromagnetic interference while simultaneously preventing current loops with high compensating currents.

A capacitor (approx. 10 nF) with a fixed dielectric (ceramic) and a test voltage > 1500 V can be installed in the safe area for this purpose.

**The final decision regarding the most suitable shielding concept must be based on a detailed observation of the equipotential bonding system.**

**Example 1:**

If a low-impedance equipotential bonding system (building grounding system) is effective under all operating conditions, both ends of the shield must be connected and grounded. Caution is necessary, however, if transients that cannot be statically measured are produced when machines are switched.

**Example 2:**

If there is no equipotential bonding system or only a poor system, or if the equipotential bonding system does not have a very low impedance or has a high noise voltage, variant 2 or 3 should be preferred.

Which of these three concepts is used must be determined by the user on a case-to-case basis (best interference suppression and safety).

No liability can be accepted by the manufacturer for this decision.





A non-connected shield at the VisuNet RM/PC end must always be properly insulated in order to prevent sparking!

The Box-10-A (Ethernet patch panel) allows the shield to be optionally connected or not connected to ground. It is connected by means of a small contact spring on the DIN rail.

Each user must ascertain which form of EMC protection is necessary, and offers sufficient reliability for their particular installation. In systems that are relatively insusceptible to electromagnetic interference, it may be adequate to connect and ground only one end of the shield.

### 10.4.2 Assembly Instructions for Ex EMC Cable Glands

The supply cables for the Ex e Ethernet and the RS485 or TTY Ex e data interface, the Ex i keyboard and the Ex i scanner must be shielded, in order to ensure sufficient immunity to interference (EMC). The cable shields must be connected to the VisuNet RM/PC in accordance with the assembly instructions below:

	<p>Step 1</p> <ul style="list-style-type: none"> <li>▪ Strip the cable</li> <li>▪ Uncover the braiding</li> <li>▪ Strip the braiding and insulation staircase-style</li> <li>▪ With thin cables, the braiding can be folded back over the insulation jacket</li> <li>▪ Insert the cable into the gland until the braiding reaches the contact position</li> <li>▪ Tighten the gland</li> </ul>
	<p>Step 2</p> <ul style="list-style-type: none"> <li>▪ Insert the cable through the union nut</li> <li>▪ Insert the cable into the clamping insert</li> <li>▪ Fold the braiding over the insert</li> <li>▪ The braiding must overlap the O-ring by approx. 2 mm</li> </ul>
	<p>Step 3</p> <ul style="list-style-type: none"> <li>▪ Fit the clamping insert into the intermediate gland</li> <li>▪ Assemble the cable gland</li> <li>▪ That's all!</li> </ul>
	<p>If the braiding ends in the cable gland</p>

## 11 Accessories

### 11.1 Box A-10 (Ethernet RJ45 1 Off Patch Field Element)

Order code Box-A10	Order number
Box-A10-Kat.7-RJ45-Mini Patch	520242

### 11.2 Holder for Barcode Reader

Order code holder for barcode reader	Order number
Scanner-Holder-Visunet-RM/PC	208140

### 11.3 Cables

Order code Power supply cable Variants see chap. 10.3.9	Order number
DATL-A2-2.5-1	205285
DATL-A2-2.5-1-Flex	205286
DATL-A2-4.0N/2.5F-2	206496

Order code Ethernet cable:	Order number
DATL-C7TP-1-1RJ45 (E. g. from VisuNet – to switch)	200884
DATL-CAT71-8-2 (VisuNet - Box-A10 Patch field element)	193075

Order code cable:	Order number
DATL-A4-0.75-3 VisuNet – EXOM (EXOM = Cradle of the barcodereader)	193070

### 11.4 Fuse Set

Order code fuse set	Order number
FUSE-RM/5PC4-1ATL	209640

### 11.5 Jack 4W

Order code Jack 4W	Order number
Buchse-4W	520248

## 11.6 Pedestal/Support-Arm/Ceiling

Order code	Order number
<b>Pedestals</b>	
PEDESTAL5-1458-FIX	198769
PEDESTAL5-1458-TURN	198770
PEDESTAL5-1458-TILT	198771
PEDESTAL5-1458-TURN-TILT	198772
<b>Table housing</b>	
PEDESTAL5-0528-FIX-Y	203537
<b>Support-arms</b>	
Support-Arm5-350-350-fix	198777
Support-Arm5-350-350-TURN	203401
Support-Arm5-350-350-TILT	198779
Support-Arm5-350-350-TURN-TILT	203402
<b>Ceilings</b>	
CEILING5-ZZZZ-FIX	198773
CEILING5-ZZZZ-TURN	198774
CEILING5-ZZZZ-TILT	198775
CEILING5-ZZZZ-TURN-TILT	198776

## 11.7 Pedestal BasicLine

Order code	Order number
<b>Pedestal BasicLine</b>	
PEDESTAL5-1458-FIX-BL	242087

## 11.8 Keyboards EXTA2

Order code keyboard EXTA2	Order number
Optional Example: EXTA2-J-T-K4-DE-U-02-CF-Z-10-N	optional

11.9 Packing Set: VisuNet Front Plate Protection

Order code front plate protection	Order number
For 19" devices: SPARE-PROTECTPLATE-VISUNET-EX1-19	221502
For 15" devices: SPARE-PROTECTPLATE-VISUNET-EX1-15	228546

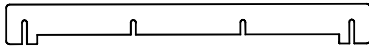

Protect plate

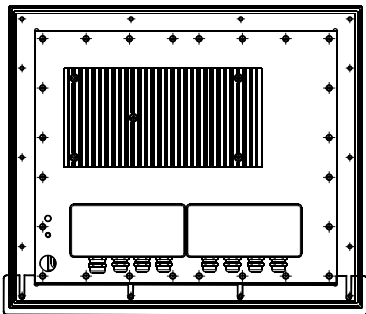

Protect plate mounted

## 12 Replace a Blown Fuse

(Fuse set: FUSE-RM5/PC4-1ATL)

Disconnect device from power supply and wait at least three minutes

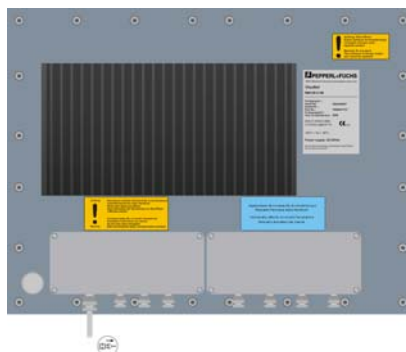

Unscrew the four screws of the Ex-e terminal box with an appropriate tool and open the Ex-e terminal box by removing the cover.

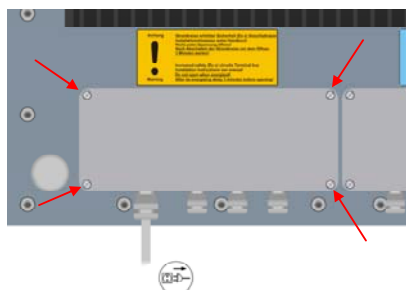

Disconnect the fuse from terminal 3 and 4 and remove the screw of the fuse holder with an appropriate tool.

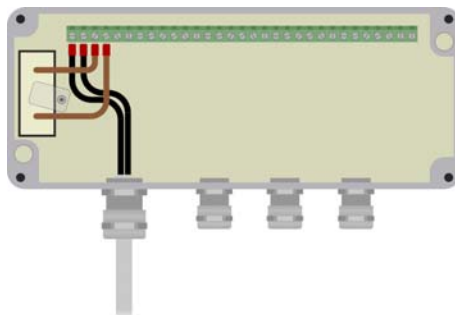

Remove the fuse holder and withdraw the blown fuse.

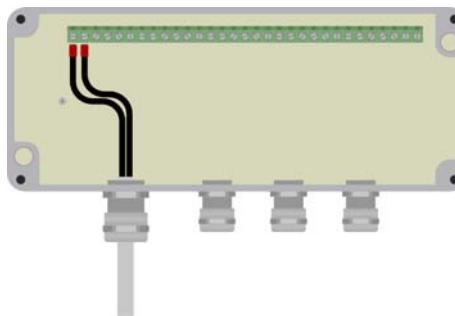

The new fuse has to be installed in reversed order.

### 13 Dictionary for VisuNet

10Base-T	Network card capability	10 MBit/s, Baseband (one signal per time), Twisted pair cable
100Base-TX	Network card capability	100 MBit/s, Baseband (one signal per time), Twisted pair cable, max 100m per segment
100Base-FX	Network card capability	100-1000 MBit/s, Baseband (one signal per time), Fibre Optic cable, usually multimode fibre (max 2000m per segment). Uses ST connectors.
1000Base-SX	Network card capability	1000 MBit/s, Baseband (one signal per time), Fibre Optic cable, usually multimode fibre (max 2000m per segment). Uses SC connectors.
802.11.a....n	IEEE Norm	for wireless data transmission (W-LAN) b: 11MBit/s g: max 54MBit/s
Access-Point	Hardware for W-LAN	Usually a Router with additional radio hardware and antenna(s) for the 802.11... standard, to connect W-LAN clients to this Access-Point
CAT.5 .. 7	Cable specification	8-wire Twisted Pair (TP) cable. CAT.5: unshielded (UTP), max. 100MBit/s, max. 100m CAT.6: shielded individual pairs, max.100MBit/s, max. 100m CAT.7: shielded individual pairs plus cable shield, max. 1000MBit/s, max 100m
Client	PC Type (Function)	PC in a Network which partly uses the data and functionality of a Server.
Cross-Link-Cable	Cable type	for direct connection of two computers, Receive and Transmit pins are crossed.
CSMA/CD		Carrier Sense Multiple Access with Collision Detection. Several participants detect whether the cable is occupied, individually send their data, and, if nevertheless a collision occurs, it is detected and the data are resend after an arbitrary, short time span. ISO-OSI Layer 2 definition.
DHCP	Address Finding	Dynamic Host Configuration Protocol. Functionality, that enables together with a corresponding host, the automatic address allocation procedure in a computer network.
DSL	Protocol	Digital Subscriber Line. It is a technology to enable high speed data transmission on basic 2-wire or 4-wire copper cables SHDSL is a high speed symmetric version of the DSL protocol family. Max transmission length depends on cable cross section.

2015-01



Ethernet	Network definition	global Definition for distributed, packet-switching, local computer networks (IEEE 802.3), e.g. it defines the use of Twisted Pair cables (physical Layer), its connectors (physical layer) and the use of the CSMA/CD standard (connection layer). speed 10MBit/s, 100MBit/s, 1000MBit/s, topology: Star
Fast Ethernet	Network definition	synonymous for Ethernet with 100MBit/s
Fire Wall	Software (Hardware)	Is a system of Software, and sometimes also hardware components, to regulate the data traffic between computer networks to implement a security concept
Full-Duplex	Data transmission	A participant in the network can send and receive data at the same time
Half-Duplex	Data transmission	A participant in the network can either send or receive data at the same time
Hub	Network Hardware	Central data distributor in a star topology network. It exists as active and passive device. Establishes a channel connection between an incoming port and one/all outgoing ports, blocking of incoming data from other ports are possible. It can only work in Half-Duplex Mode.
Internet	Network Structure	INTERconnected NETworks, is an electronic connection between computers to exchange data. It is established worldwide and it uses normalized Internet Protocols like the TCP/IP. www World Wide Web is one of the established services.
Intranet	Network Structure	is a computer network, which uses the same techniques as the Internet does (TCP/IP, HTTP), but it can only be used by a predefined group of an organisation.
IP-Address	Address schematic	Definition version 4 of the address schematic in IP-networks. Private networks should have the address 192.168.xxx.xxx and will not be routed in the internet

2015-01

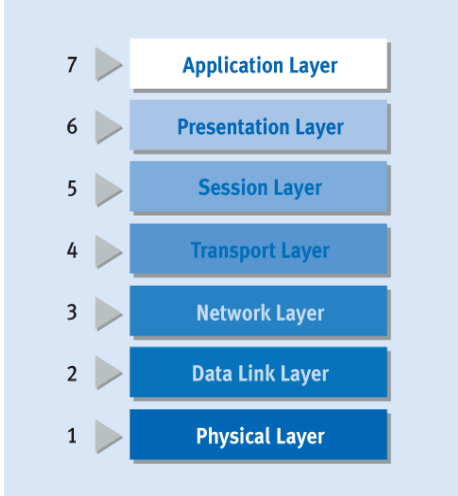
ISO / OSI reference model			<p>Is an Open System Interconnection standard, introduced by the International Standardisation Organisation (ISO) in 1984. It consist of 7 layers to represent the different levels of communication in a very general form.</p> <p>Layer 1 is the physical layer and specifies e.g. the cable type of an electrical data communication and how bits are transferred (e.g. 100BaseTX).</p> <p>Layer 2 shall specify the basic representation of the data and e.g. its correctness after reception (frames, e.g. Ethernet)</p> <p>Layer 3 is the Network layer and e.g. administrates the partners in a communication and their addresses (packets, e.g. IP))</p> <p>Layer 4 is the connection between the system layers 1 – 3 and the application (e.g. TCP)</p> <p>Layers 5 - 7. Here the addressing / decoding and multiplexing / demultiplexing of the data shall be defined.</p> <p>Layers 5, 6 and 7 care on the further forward of the data up to the interface between application and computer.</p>
LAN	Network Type	Local Area Network, max layout within a room, building or the own premises	
MBit/s	speed unit for data	Megabit per second, data transfer rate between two points	
Network		connection of min. 2 points to transfer e.g. information	
RDP	Protocol	Remote Desktop Protocol, built-in in the Microsoft operating systems Windows 2000 Server, XP pro, 2003 Server and Vista. Also 3 <sup>rd</sup> party products from several software houses. Software protocol for compression and transfer of keyboard, video, mouse and serial interface data from one computer to another. It is hereby possible to completely control a	

		far distant PC, e.g. through a network. TCP/IP is usable as transport protocol.
Network Operating System		Microsoft Windows XP Pro, Windows 2000 Server, Windows 2003 Server, Novell NetWare offer the functionality for Client/Server Networks
Repeater	Network Hardware	Is an active device which refreshes and amplifies the network signals in a cable (ISO-OSI Level 1). It offers another e.g. 100m cable length in an Ethernet network.

RJ45	Connector Type	Western type connector, standard for Ethernet and Fast Ethernet cables, 8 contacts
Router	Network Hardware	Establishes a connection to other networks and creates herewith subnetworks. It knows all addresses and other routers in the network for optimal data flow. It has an own network address.
SC	Connector Type	Fibre Optic (F.O.) industrial connector
Server	PC Type (Function)	usually a dedicated PC in a Network which supplies Database functionalities and Network Services to the connected Clients
Switch	Network Hardware	Central data distributor in a star topology network. It amplifies and individually distributes the incoming data at full speed for all participants. Recognizes and remembers addresses and ports. It knows all addresses in the network. It works in Full-Duplex-Mode.
ST	Connector Type	Fibre Optic (F.O.) industrial connector
TCP/IP	Protocol	Transmission Control Protocol (TCP, transport layer) with Internet Protocol (IP, network layer). It is a reliable, connection oriented protocol for computer networks.
Terminal Server	Protocol, Function	is a functionality based on the RDP protocol. It enables a far away PC to have control over another PC though a network
UDP	Protocol	User Datagram Protocol , is a minimal, connectionless network protocol, which is responsible for the data

2015-01

		transportation to the correct destination in the Internet Alternatively used to TCP
UTP	Cable Type	Unshielded Twisted Pair cable
W-LAN	Network Type	Wireless Network
WAN	Network Type	Wide Area Network, also MAN (Metropolitan Area Network) and GAN (Global Ara Network)
WiFi	organisation	Wireless Fidelity. Organisation which certifies products of different manufacturers for their interoperability according the IEEE 802.11 W-LAN standards.







2015-01

# PROCESS AUTOMATION – PROTECTING YOUR PROCESS



#### Worldwide Headquarters

Pepperl+Fuchs GmbH  
68307 Mannheim - Germany  
Tel. +49 621 776-0  
E-mail: [info@de.pepperl-fuchs.com](mailto:info@de.pepperl-fuchs.com)

For the Pepperl+Fuchs representative  
closest to you check [www.pepperl-fuchs.com/contact](http://www.pepperl-fuchs.com/contact)

[www.pepperl-fuchs.com](http://www.pepperl-fuchs.com)

Subject to modifications  
Copyright PEPPERL+FUCHS • Printed in Germany

 **PEPPERL+FUCHS**  
PROTECTING YOUR PROCESS

266858 / TDOCT-3675AENG

01/2015