

2-D LiDAR Sensor

OBD*-R2000-*

Manual



Your automation, our passion.

 **PEPPERL+FUCHS**

With regard to the supply of products, the current issue of the following document is applicable:
The General Terms of Delivery for Products and Services of the Electrical Industry, published
by the Central Association of the Electrical Industry (Zentralverband Elektrotechnik und Elek-
troindustrie (ZVEI) e.V.) in its most recent version as well as the supplementary clause:
"Expanded reservation of proprietorship"

Worldwide

Pepperl+Fuchs Group
Lilienthalstr. 200
68307 Mannheim
Germany
Phone: +49 621 776 - 0
E-mail: info@de.pepperl-fuchs.com

North American Headquarters

Pepperl+Fuchs Inc.
1600 Enterprise Parkway
Twinsburg, Ohio 44087
USA
Phone: +1 330 425-3555
E-mail: sales@us.pepperl-fuchs.com

Asia Headquarters

Pepperl+Fuchs Pte. Ltd.
P+F Building
18 Ayer Rajah Crescent
Singapore 139942
Phone: +65 6779-9091
E-mail: sales@sg.pepperl-fuchs.com
<https://www.pepperl-fuchs.com>

1	Introduction.....	5
1.1	Introduction.....	5
1.2	Validity	5
2	Declaration of Conformity.....	6
3	Safety	7
3.1	Symbols Relevant to Safety	7
3.2	Safety Notices	7
3.3	Laser Class 1	8
3.4	Intended Use	8
4	Product Description	9
4.1	R2000 Laser Scanner	9
4.2	Functional Principle.....	10
4.3	Indicators and Operating Controls	11
4.4	Interfaces and Connections	11
4.5	Included in Delivery.....	12
4.6	Accessories.....	13
5	Installation.....	14
5.1	Storage and Transport.....	14
5.2	Unpacking	14
5.3	Mounting.....	14
5.4	Device Connection.....	15
5.5	Grounding / Shielding	16
6	Commissioning.....	17
6.1	Ethernet Configuration.....	17
7	Operation.....	20
7.1	Menu Structure	20
7.2	Operation.....	23
7.3	Description of Menu Items.....	25
7.3.1	"Ethernet Info" Menu Item	25
7.3.2	"Ethernet Setup" Menu Item	26
7.3.3	Sensor Setup Menu Item	26
7.3.4	"Tools" Menu Item.....	27
7.3.5	"End" Menu Item.....	28

8	Maintenance and Repair	29
8.1	Maintenance	29
8.2	Repairs	29
9	Troubleshooting	30
9.1	Troubleshooting	30
10	Appendix	32
10.1	Pulse Ranging Technology (PRT) Glossary	32
10.2	Using Open Source Programs	33

1 Introduction

1.1 Introduction

Congratulations

You have chosen a device manufactured by Pepperl+Fuchs. Pepperl+Fuchs develops, produces and distributes electronic sensors and interface modules for the market of automation technology on a worldwide scale.

Read these instructions carefully before you install this device and put it into operation. Instructions and hints included in this manual lead you step by step through the installation and commissioning and provide a trouble-free use of this product. This is for your benefit, since this helps you to:

- ensures the safe operation of the device
- exploit the full functionality of the device
- avoid operating errors and related disturbances
- avoid costs due to disruptions and repair work
- increase the effectiveness and efficiency of your system.

Keep these instructions for reference for later work on the equipment.

Please check after opening the package, that the device isn't damaged and the completeness of the delivered goods.

Symbols used

The following symbols are used in this manual:



Note

This symbol draws your attention to important information.



Handling instructions

You will find handling instructions beside this symbol

Contact

If you have any questions about the device, its functions, or accessories, please contact us at:

Pepperl+Fuchs Group
Lilienthalstraße 200
68307 Mannheim, Germany
Telephone: +49 (0)621 776-1111
Fax: +49 (0)621 776-271111
Email: fa-info@de.pepperl-fuchs.com

1.2 Validity

This manual applies to devices from firmware 1.20 and hardware 1.00 onward. The versions can be found in the device menu; .

For devices with older versions, documentation is available on request.

2 Declaration of Conformity

All products were developed and manufactured under observance of the applicable European standards and guidelines.



Note

A declaration of conformity can be requested from the manufacturer.

The product manufacturer, Pepperl+Fuchs Group, has a certified quality assurance system that conforms to ISO 9001.



3 Safety

3.1 Symbols Relevant to Safety



Danger!

This symbol indicates an imminent danger.

Non-observance will result in personal injury or death.



Warning!

This symbol indicates a possible fault or danger.

Non-observance may cause personal injury or serious property damage.



Caution!

This symbol indicates a possible fault.

Non-observance could interrupt the device and any connected systems and plants, or result in their complete failure.

3.2 Safety Notices

Read the following information carefully and follow this information when working with the device. Failure to observe the safety notices and warning messages in this documentation can lead to malfunctions and hazardous operating scenarios during operation.

This can result in serious personal injury or death.

Target Group, Personnel

The personnel must be appropriately trained and qualified in order to carry out mounting, installation, commissioning, operation, maintenance, and dismounting of the device. The trained and qualified personnel must have read and understood the instruction manual.

Prior to using the product make yourself familiar with it. Read the instruction manual carefully.

Reference to Further Documentation

Observe directives, standards, and national laws applicable to the intended use and the operating location.

Intended Use

The R2000 2-D LiDAR sensor is a 360° measuring instrument with an all-round display. It is used on automated transport systems or other movable machinery in intralogistics. It is also used on stationary equipment in the area of factory and building automation.

The device is only approved for appropriate and intended use. Ignoring these instructions will void any warranty and absolve the manufacturer from any liability.

Operation, Maintenance, Repair

Do not remove the nameplate.

Do not remove the warning markings.

Do not repair, modify, or manipulate the device.

If there is a defect, always replace the device with an original device.

Only use accessories specified by the manufacturer.

When using the device with rack feeders and moving carriages, observe the applicable safety guidelines for these applications.

Supply the device with a power supply that meets the requirements for safety extra-low voltage (SELV) or protective extra-low voltage (PELV).

Do not point the device directly at the sun. Do not use the device to conduct measurements into the sun.

Delivery, Transport, Disposal

Keep the original packaging. Always store and transport the device in the original packaging.

The device, built-in components, packaging, and any batteries contained within must be disposed in compliance with the applicable laws and guidelines of the respective country.

3.3 Laser Class 1

Class 1 Laser Product

This sensor is certified according to laser protection class 1.



Warning!

Class 1 laser light

The laser light can be an irritant, especially in a dark environment. Do not point lasers at people!

Maintenance and repairs should only be carried out by authorized service personnel!

Install the device so that the warning is clearly visible and readable.

Caution: Use of controls, adjustments, or performance of procedures other than those specified herein may result in harmful laser beam exposure.

3.4 Intended Use

The R2000 laser scanners are measuring devices that are used on automated transport systems or other movable machinery in intralogistics. They are also used on stationary equipment in the area of factory and building automation.

Make sure that the devices are used only for their intended purpose.

4 Product Description

4.1 R2000 Laser Scanner

The two-dimensional R2000 laser scanner is made up of a static body, on which a continuously turning measurement module with an emitter laser and receiver element is located. The laser scanner uses pulse ranging technology (PRT). The implementation of this innovative functional principle permits continuous scanning of the surroundings through a full 360°.

The measurement data is evaluated in an integrated control interface for monitoring tasks and the results made available at up to four switching outputs. The binary switching signals can be further processed by external controllers or other decentralized intelligent automation components. The monitoring fields are defined using a device type manager (DTM). This DTM can be used in an FDT frame application such as PACTware, so that graphically supported parameterization of monitoring fields takes place on the PC screen. The monitoring fields can handle virtually any geometric shape. A monitoring field can extend over a full 360°, but likewise may include only a portion. Up to four fields can be configured. Typical applications for the 2-D laser scanner include object detection, area monitoring, and collision prevention. One particular strength of the device is the detection of small objects. In going about this task, the sensor combines its above-average detection performance with maximum ease of use.

One particular highlight of the laser scanner is the row of LEDs arranged on the back of the measurement module. Rotating the scanner produces a cylinder-shaped projection surface, which is suitable for displaying text-based as well as graphical information. In this way, commissioning and operations can be carried out without aids such as a PC or Notebook. Operating and diagnostic information can be seen directly during ongoing operation.

The laser scanner from the R2000 series fulfills the safety requirements of laser class 1 in measurement mode. The low amount of laser light emitted guarantees that operating personnel are neither injured nor harmed.



4.2 Functional Principle

The laser scanner works according to the principle of pulse ranging technology (PRT). As part of this principle, the time between sending a visible light pulse and receiving the reflected pulse from the object is measured in the device. Due to the constancy of the speed of light, this time is a distance measurement.

In comparison with other distance measurement processes, time-of-flight measurement is affected very little by any disturbances in the measuring environment. As a result, this measurement process can be used with a high level of accuracy even under tough everyday industrial conditions. The light source and light receiver are located in the rotating sensor head.

In the integrated measurement data evaluation, the measurements are compared with up to four configured monitoring fields. The results can be logically linked in two levels and read out at up to four outputs. Up to four inputs can be integrated into the logical linking of the monitoring fields. The laser scanner has four I/Q connections so that an appropriate combination of inputs and outputs is possible.

Note

Influence of Ambient Conditions

The speed of light depends on the air temperature and barometric pressure.

The influence of the air temperature amounts to 1 ppm/K.

The influence of the barometric pressure amounts to -0.3 ppm/hPa.

These faults must be taken into consideration by the user in the case of longer distances.

In the operating range (-10 °C ... +50 °C) this fault amounts to 0.6 mm at a distance of 10 m.

4.3 Indicators and Operating Controls

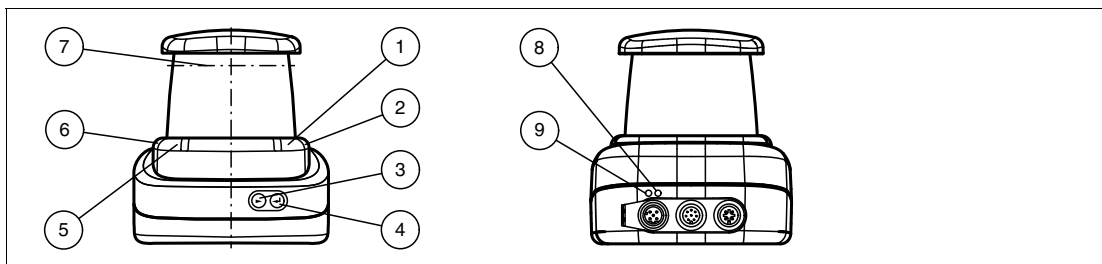

Figure 4.1 Indicators and Controls

No.	Designation	Color
1	Operating status indicator	Green
2	Error indicator	Red
3	"Next" menu button	
4	"Return" menu button	
5	Q2—input/output 2	Yellow
6	Q1—input/output 1	Yellow
7	Laser face	
8	Ethernet activity indicator	Yellow
9	Ethernet link indicator	Green

Table 4.1 Indicators and Operating Controls

4.4 Interfaces and Connections

The following connections are found on all devices:

Power Supply

There is a 4-pin M12 connector on the rear of the housing to connect the power supply. The following diagram shows the pinning:

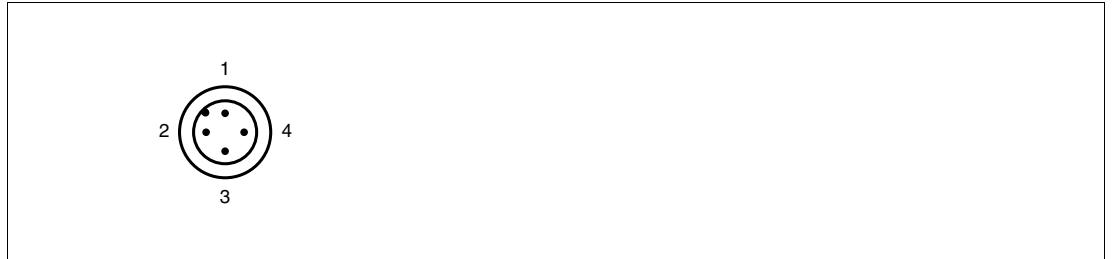
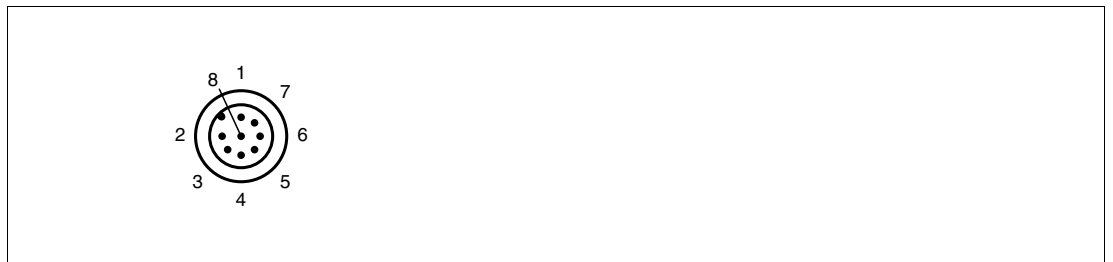

Figure 4.2 Power supply connection layout

- 1 24 V power supply
- 2 I/Q2
- 3 Ground (GND)
- 4 I/Q1

MultiPort

An 8-pin M12 connector is located on the rear of the housing. Inputs/outputs 3 and 4 are located here



- 1 DNC (Do not connect)
- 2 DNC (Do not connect)
- 3 DNC (Do not connect)
- 4 I/Q3
- 5 I/Q4
- 6 I/Q2
- 7 I/Q1
- 8 DNC (Do not connect)

All pins with "DNC (Do not connect)" must not be connected!

Interface:

There is a 4-pin M12 socket on the back of the housing to connect the Ethernet interface. The following diagram shows the pinning:

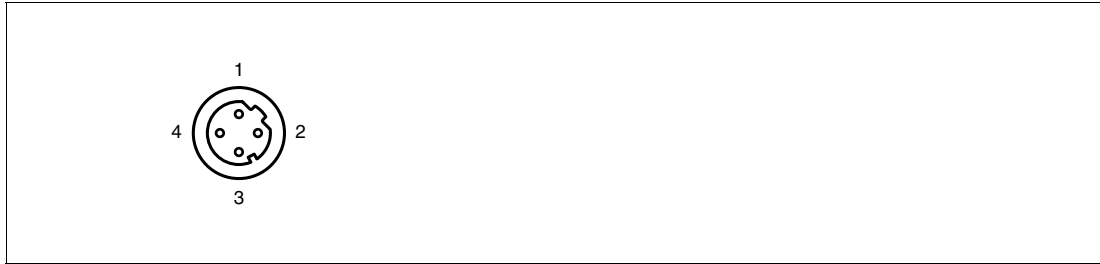

Figure 4.3 Ethernet connection layout

- 1 TD+
- 2 RD+
- 3 TD-
- 4 RD-

The connector housing is located on the shield.

4.5 Included in Delivery

The delivery package contains:

- R2000 2D laser scanner
- Quick start guide
- Protective cover for MultiPort and Ethernet
- 3 x socket cap screws, M5 x 10
- 3 x washers, size 5

4.6 Accessories

The following products are available as accessories.

Designation	Description
V1SD-G-2M-PUR-ABG-V45-G	Patch cable M12 to RJ45, length 2 m
V1SD-G-5M-PUR-ABG-V45-G	Patch cable M12 to RJ45, length 5 m
V1SD-G-ABG-PG9	Single-ended male cordset, M12 D-coded, 4-pin for bus cable
V1-G-2M-PUR	Single-ended female cordset, straight, M12, 4-pin, PUR cable, length 2 m
V1-G-5M-PUR	Single-ended female cordset, straight, M12, 4-pin, PUR cable, length 5 m
V1-W-2M-PUR	Single-ended female cordset, angled, M12, 4-pin, PUR cable, length 2 m
V17-G-2M-PUR	Single-ended female cordset, straight, M12, 8-pin, shielded, PUR cable, length 2 m
V17-G-5M-PUR	Single-ended female cordset, straight, M12, 8-pin, shielded, PUR cable, length 5 m
V1S-B	Blind plugs



Note

Installation Information for North America

If a connection is made with the M12 multi-pin connector, then in the final installation of the power supply, the product must be used with a UL-listed cable/connector assembly (CYJV) that is designed for at least 30 VDC and at least 1.0 A.

Designation	Description
V1-G-BK-2M-PUR-U	Single-ended female cordset, straight, M12, 4-pin, PUR cable, length 2 m, "UL recognized"
V1-G-BK-5M-PUR-U	Single-ended female cordset, straight, M12, 4-pin, PUR cable, length 5 m, "UL recognized"
V1-G-BK-10M-PUR-U	Single-ended female cordset, straight, M12, 4-pin, PUR cable, length 10 m, "UL recognized"

5 Installation

5.1 Storage and Transport

Package the device for storage and transport such that it is protected from impact and moisture. The original packaging provides optimum protection. Also take note of the permitted ambient conditions.



Note

If the temperature is subject to major fluctuations during transport, the device must be allowed to acclimatize for around two hours prior to installation and use. During this acclimatization period, avoid subjecting the device to condensation at all costs, as this could have an effect on internal parts and cause damage.

5.2 Unpacking

Check the product for damage while unpacking. If the product should be damaged, inform the post office or parcel service and notify the supplier.

Retain the original packaging in case the device must be stored or shipped again at a later date.

Should you have any questions, please contact Pepperl+Fuchs.

5.3 Mounting



Caution!

Safety information

Do not point the sensor into the sun.

Protect the sensor against direct and prolonged sunlight.

Prevent condensation from forming by ensuring that the sensor is not subjected to any major temperature fluctuations.

Do not subject the sensor to aggressive chemicals.

Keep the glass on the device clean.

For cleaning, use only water (if necessary with a little detergent) and a soft microfiber cloth! The use of other detergents is not permitted! The glass must never be cleaned when dry!

The device can be fitted with the supplied socket head screws with washers on the underside of the device.



Caution!

Screw-in depth

The maximum screw-in depth in the base must not exceed 8 mm, otherwise the device will be mechanically destroyed! The minimum screw-in depth is 5 mm.

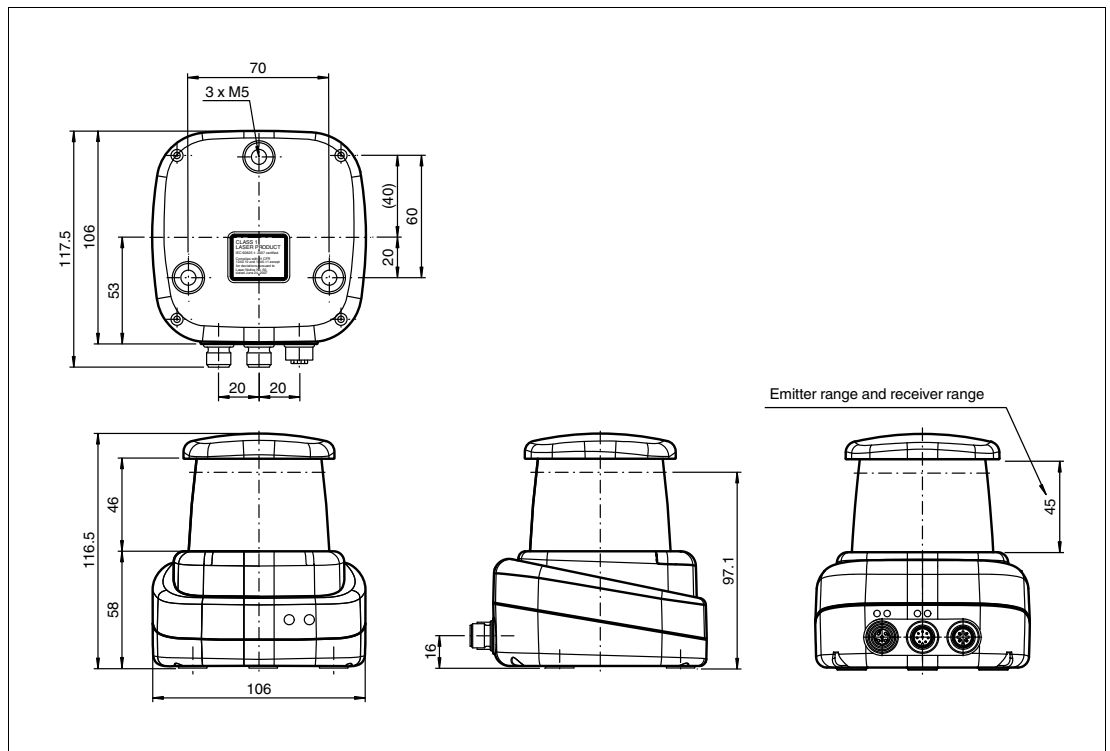

Figure 5.1 Dimensional drawing R2000



Note

Keep the emitting/receiving area clear

During assembly, make sure that the emitting/receiving area is kept clear. If the emitting/receiving area is covered, this reduces the performance of the 2D laser scanner.

5.4 Device Connection



Electrical connection in line with IP65

1. Put protective covers on unused M12 connectors.

↳ The IP65 protection class is achieved. The protective covers can be ordered as accessories

The device conforms to protection class III. This means that the power has to be supplied as a low protective voltage (PELV).

The power supply of the device is 10 VDC ... 30 VDC. On account of the integrated motor, an increased level of startup current is required compared with normal operation. It is recommended that power supplies with 1 A (at 24 V) or with 2 A (at 12 V) are used.

The maximum cable length is 30 m.

The pin assignment is as follows:

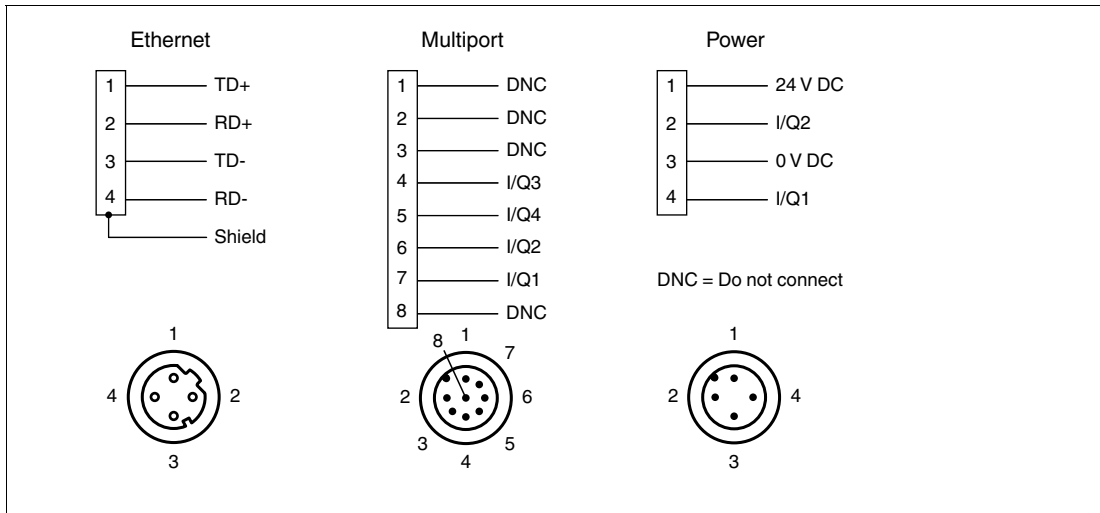

Figure 5.2 R2000 pin assignment

5.5 Grounding / Shielding

The grounding of the cable shields on the metallic flush-type connectors is not protective grounding in the sense of personnel protection, but is a functional grounding.

The functional grounding of the cable shields is recommended, if the housing does not have its own grounding. In environments with severe interference, it is also sensible to shield and to position the shield on both sides.

For shield grounding, use the preassembled insertion prong, which is fixed to the Ethernet socket.



2024-11

6 Commissioning



1. Connect the device to the power supply.
 - ↳ The initialization phase lasts approx. 10 seconds. This phase is indicated by an illuminated Power LED. The display is still disabled in this phase.
2. There is another initialization phase that lasts approx. 10 seconds.
 - ↳ The display turns on and shows circles moving downward.
3. After the initialization phase, the Pepperl+Fuchs logo will appear.
 - ↳ The device is ready for operation.

To achieve the best measurement accuracy, allow the device to warm up for 30 minutes.

The sensor has been tested and calibrated before delivery. It can be put into operation immediately.

It is generally recommended to use a dedicated network card for the connection to the device.

For parameterization, connect the device to an Ethernet interface on a computer. Install the PACTware software and the appropriate DTM.

6.1 Ethernet Configuration

The device has three different address modes. Select your preferred mode from the modes described below. The setting is configured directly on the device using the menu interface.

Auto IP

In this mode, the device independently selects a "Link-Local" IP address in the 169.254.0.0/16 range. During this process, measures are taken to ensure that the selected address is not already being used by another device.

The device is configured to Auto IP by default. The Auto IP setting is the ideal way to establish a direct connection to a PC. Set the DHCP mode (Dynamic Host Configuration Protocol) on the PC. To do this, select the TCP/IP protocol in the network card properties and select the "Obtain an IP address automatically" setting there. After approx. 30 seconds, Windows assigns an Auto IP for the PC.

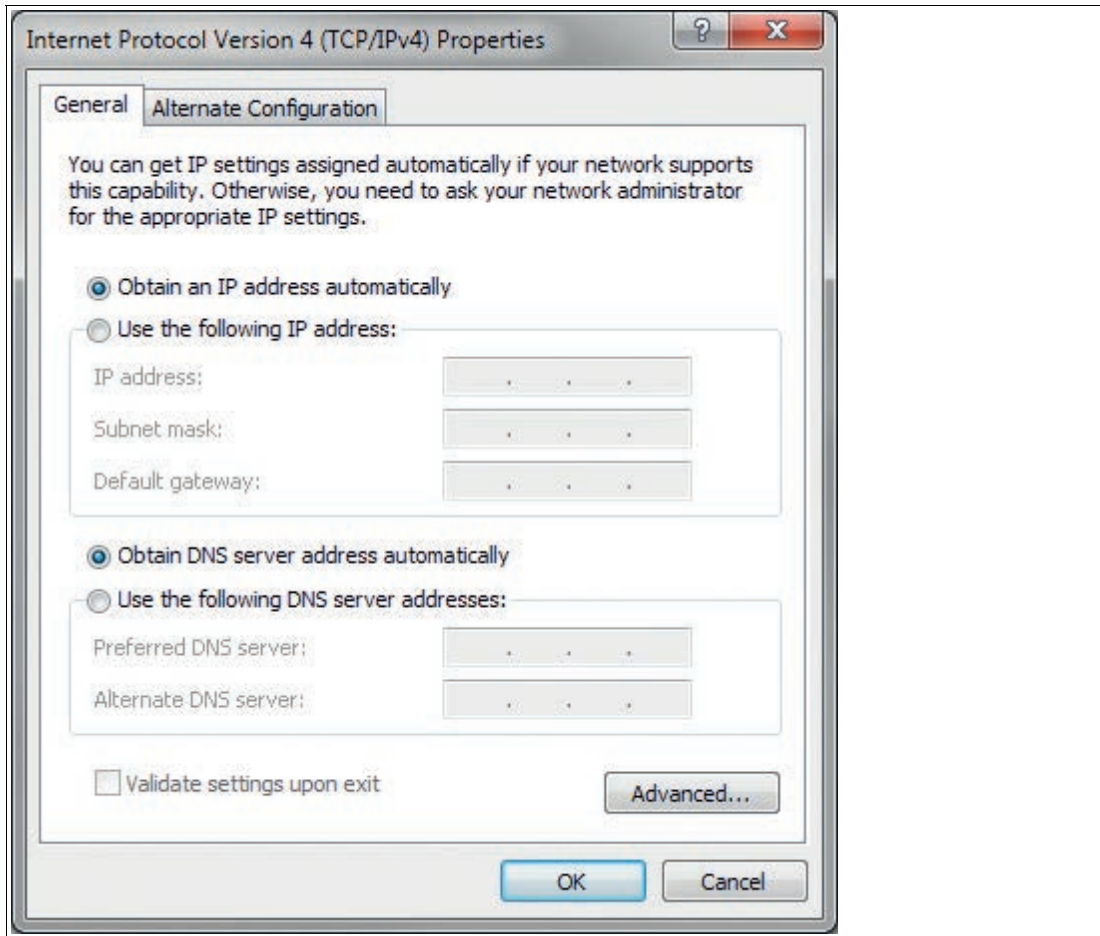

DHCP

Set the device to DHCP under the "Address mode" menu item. The DHCP configuration requires a DHCP server in the local network, e.g., a router. See the "Auto IP" item for information on this.

Manual IP

Set the device to manual under the "Address mode" menu item. The IP address is set to 10.0.10.9 and the subnet mask to 255.0.0.0 by default. To connect the device to the PC, the network card must be configured as follows.

Set the required IP address in the network card menu. Select the TCP/IP protocol in the network card properties and select the "Use the following IP address" setting there. Enter the required IP address and subnet mask.

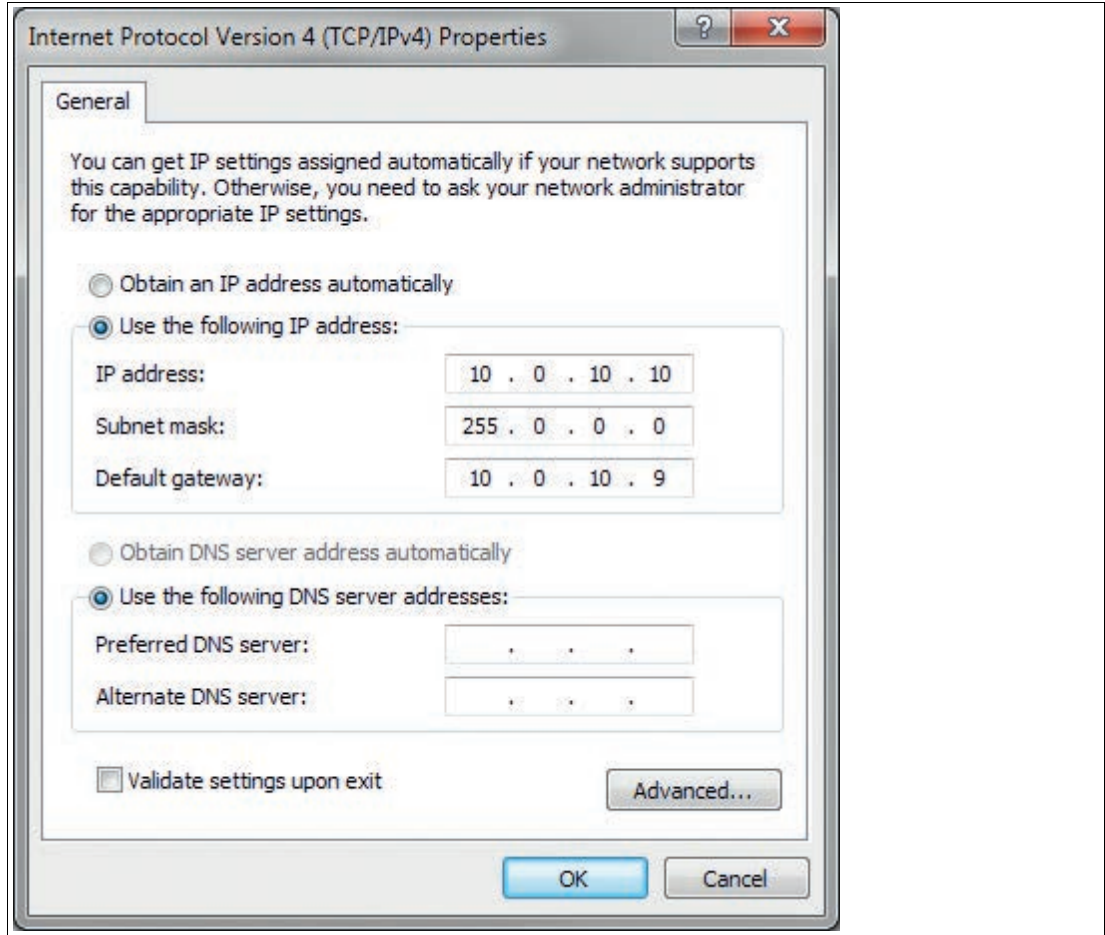

Note

Device restart

You must restart the device after changing the Ethernet configuration.

7 Operation

7.1 Menu Structure

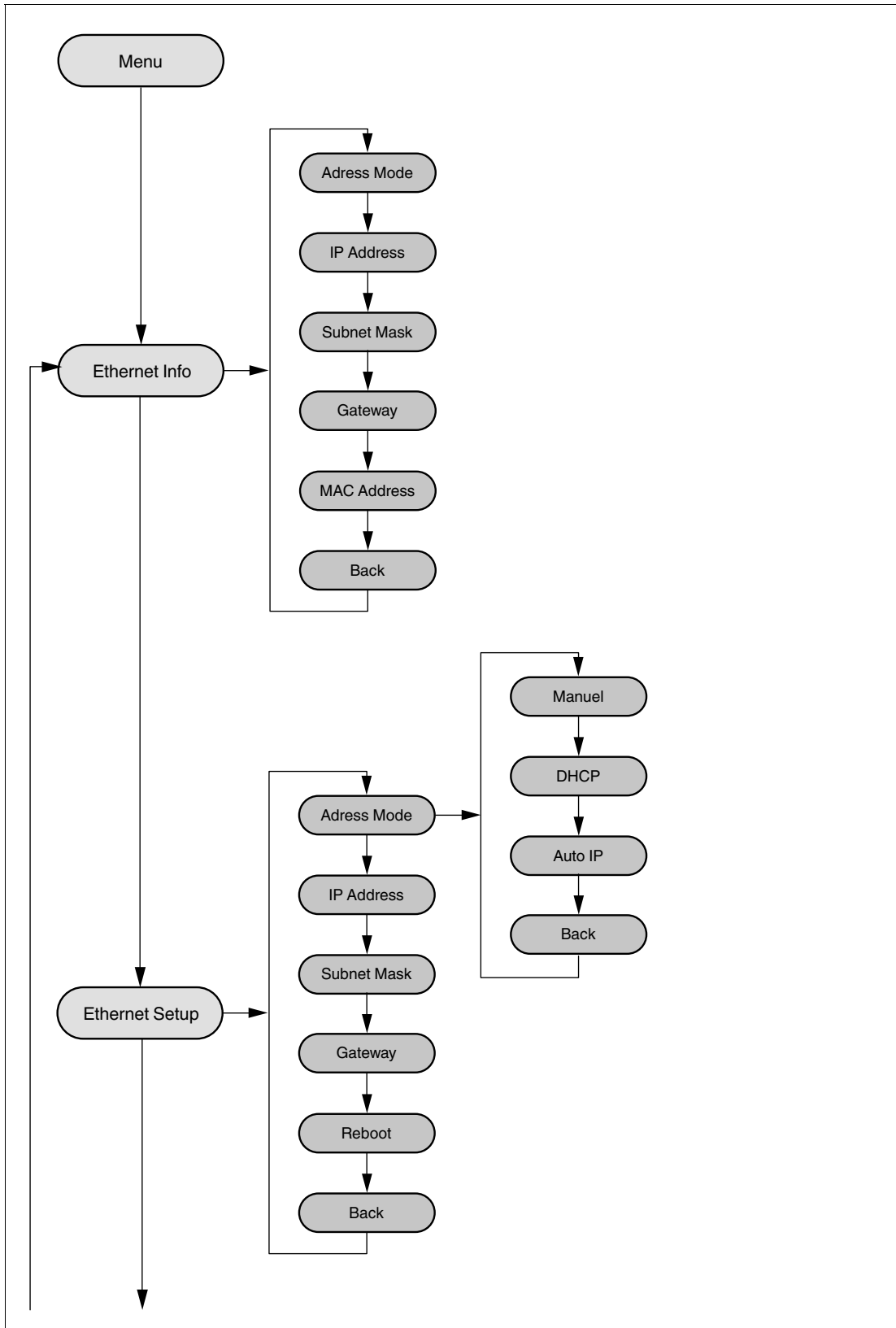

2024-11

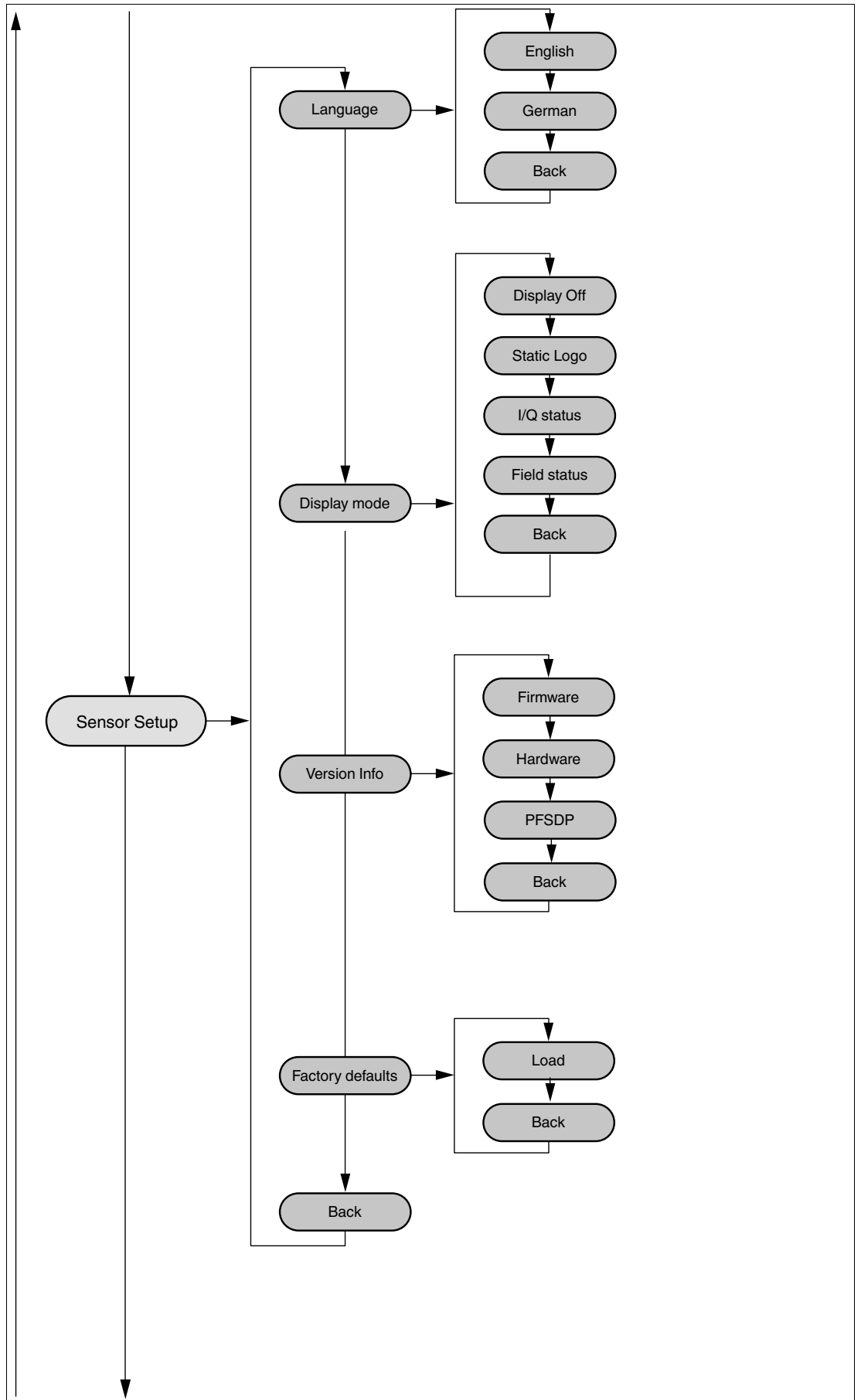

2024-11

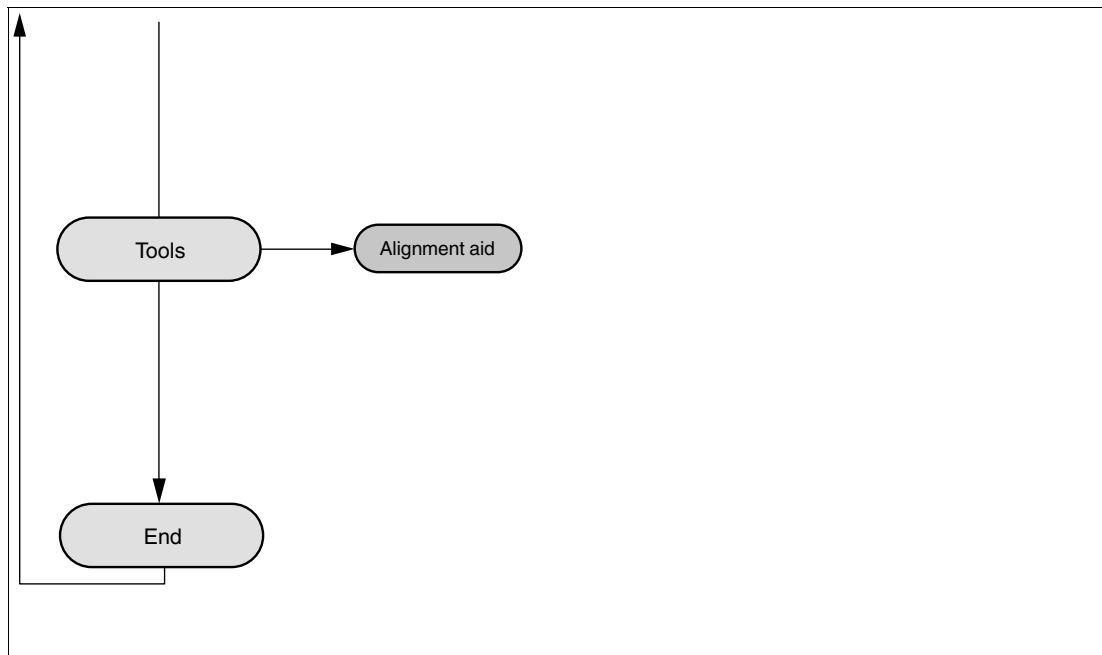

7.2 Operation

The sensor is operated using the two buttons on the front.



These buttons can be used to navigate within the menu structure.

You can also use the two buttons to change parameters or enter values.

The content of the all-round display will vary according to the input data.



Meaning of Buttons

Button	Explanation
	<p>ARROW button. Press this button</p> <ul style="list-style-type: none"> To navigate to the next menu item, To change a value. <p>This button has a similar function to the ARROW button on the computer keyboard.</p>
	<p>ENTER button. Press this button to select a menu item from the display. This button has a similar function to the ENTER button on the computer keyboard.</p>

In each menu item, the set values are indicated by an underscore. These values can be changed.





Note

Device settings may only be configured by trained and qualified personnel.

If no buttons are pressed in the menu levels for ≥ 60 seconds, the menu is exited automatically.

Navigation in the Menu



Menu display	
Top row	The current menu level is shown in the top row.
Bottom row	The currently selected element is shown in the bottom row.
Dash	One dash means you are in the main menu.
	Two dashes mean you are in the submenu.
Operation	
Pressing the ENTER button takes you into the menu structure.	
	Takes you to the next menu element.
	Keep the ARROW button or the ENTER button pressed for > 1 second to go to the next menu element up.
	Takes you to the selected menu element.
	Keep the ARROW button or the ENTER button pressed for > 1 second to go to the next menu element up.
Menu entry	
End	This menu entry exits the main menu.
Back	This menu entry takes you to the next menu element up.

Changing Count Parameters



Menu display	
Top row	This shows the current parameter.
Bottom row	This shows the currently selected parameter value.
Underlined parameter value	This is the currently activated value.
Operation	
	Takes you to the next available parameter value.
	Keep the button pressed for > 1 second to go to the next menu element up without changing the parameter.

	Activates the parameter value currently displayed.
	Keep the button pressed for > 1 second to activate the displayed parameter and return to the higher-level menu element.

Changing Numerical Parameters

Menu display	
Top row	This shows the name of the displayed parameter.
Bottom row	This shows the current value of the parameter.
Underlined parameter value	This is the parameter value to be edited.
Operation	
	Increase the currently selected digit.
	Keep the button pressed for > 1 second to increase the selected digit at a quicker rate.
	Takes you to the next editable digit.
	Keep the button pressed for > 1 second to go to the Confirm menu.
Confirm menu	
Top row	This shows the changed number.
Bottom row	This shows the executable actions (Save, Edit, Cancel).
"Save" action	The changed value is applied and saved.
"Edit" action	Takes you back to the edit display.
"Cancel" action	Rejects the changes and takes you to the higher-level menu.

IP Configuration Display

Menu display	
Top row	Name of the displayed parameter.
Bottom row	This shows the current value of the parameter.
Operation	
	Takes you to the next menu element.
	Keep the ARROW button or the ENTER button pressed for > 1 second to go to the next menu element up.
	No function.
	Keep the ARROW button or the ENTER button pressed for > 1 second to go to the next menu element up.

Back Menu Item

The "Back" menu item returns you to the higher-level menu.

7.3 Description of Menu Items

7.3.1 "Ethernet Info" Menu Item

This menu item provides quick access to the IP configuration currently in use. The data can be read only in this menu item.

Address Mode

The address mode currently being used is displayed in this subitem.

IP Address

The IP address currently being used is displayed in this subitem.

Subnet Mask

The subnet mask currently being used is displayed in this subitem.

Gateway

The gateway currently being used is displayed in this subitem.

MAC ID

The MAC ID currently being used is displayed in this subitem.



Note

Changing the IP configuration

Changes to the IP configuration are only applied after a restart.

The IP configuration currently used by the device is displayed in the "Ethernet Info" menu item. If these settings differ from the configuration specified under the "Ethernet Setup" menu item, the device must be restarted.

7.3.2 "Ethernet Setup" Menu Item

This menu item is used to change the IP configuration data.

Address Mode

- "Manual:" Enables you to manually assign the IP address, the subnet mask, and the gateway to the device.
- "DHCP:" Enables you to assign an IP address to the device from a DHCP server (e.g., a Windows® PC).
- "AutoIP:" Enables automatic detection of the device on the network.

IP Address

The IP address to be used in the "Manual" address mode can be set in this menu item.

Subnet Mask

The subnet mask to be used in the "Manual" address mode can be set in this menu item.

Gateway

The gateway can be set in this subitem.

Restart

The device can be restarted in this menu item.

**Note****Changing the IP configuration**

Changes to the IP configuration are only applied after a restart.

The IP configuration currently used by the device is displayed in the "Ethernet Info" menu item. If these settings differ from the configuration specified under the "Ethernet Setup" menu item, the device must be restarted.

7.3.3 Sensor Setup Menu Item

Language

The language can be set to German or English using this menu item.

Display Mode

The display mode defines the display in normal mode when the menu is not active. The display mode is set on a permanent basis. It is active following a restart.

- **Display off:** The display goes dark as soon as the menu is exited.
- **Static logo:** The text "Pepperl+Fuchs" is displayed.
- **I/Q Status:** The four inputs/outputs are displayed at the same time in rings. The respective input/output is indicated every 90° via points (1–4). The respective input/output is displayed even when it is not active.



- **Field Status:** The four fields are displayed at the same time in rings. The respective field is indicated every 90° via points (1–4). The respective field is displayed even when it is not active.

Version Info

- **Firmware:** The display shows the current version of the firmware.
- **Hardware:** The display shows the current version of the hardware.
- **PFSDP:** The display shows the current version of the Pepperl+Fuchs Scan Data Protocol.

Factory Defaults

The factory defaults for the sensor can be loaded in this menu item. To do this, you must select "Load" in the submenu and confirm by pressing the "Enter" button. You must restart the device to adopt all the changes.

7.3.4 "Tools" Menu Item

Alignment Aid

A bar is shown on the display at the point at which a reflector is detected. An angular scale is shown at the bottom of the display.

7.3.5 "End" Menu Item

End

Pressing the ENTER button to confirm exits the menu and displays the set display mode.

8 Maintenance and Repair

8.1 Maintenance



Caution!

Failure to clean and improper cleaning may cause property damage and malfunction

Failure to follow these instructions for cleaning the device may result in lens damage and impaired function.

Keep the glass on the device clean.

Never clean the glass on the device when the glass is dry. Always use a soft cloth and water, with a little detergent if necessary.

Do not use aggressive solvent-based cleaning agents such as acetone.

Observe the applicable national regulations when maintaining the device.

The sensor is largely maintenance free.

Check the technical safety of the sensor system at regular intervals by looking for damage to the housing. Check the sensor for dirt occasionally.

To clean the sensor, wipe it with a damp soft cloth at regular intervals. This will ensure it continues to function properly. The housing is made of plastic. For this reason, do not use acetone or detergents containing solvents.

8.2 Repairs

If it appears that safe operation of the system is no longer possible, the system must be taken out of operation and steps taken to prevent it being used inadvertently. If the device needs to be repaired, return it to Pepperl+Fuchs. If you open or modify the device yourself, not only are you endangering yourself and others but you will void any warranty and absolve the manufacturer from any liability.

9 Troubleshooting

9.1 Troubleshooting

Interference

- The sensor must be firmly mounted. It must not vibrate.
- The sensor must not be installed behind a cover.
- The sensor should be installed so it is protected from rain.

Note

When carrying out the insulation measurement, be aware that suppressor diodes have been installed for electromagnetic compatibility.

Occurring Fault Display:

- In normal operation, the display shows the current "Display Mode" view. The "Enter" button activates the menu; the "Next" button has no function
- If there are one or more warnings, the message can be displayed by pressing the "Next" button: first line: "Warning 1/3", second line: Scroll through warning message (display can be read from the front). If there are several warning messages, go to the next warning by pressing "Next". If you press "Next" and there is no other warning, the "Display Mode" view reappears
- If there is a fault, a fault indication "Fault // ..." immediately replaces the display. Only one fault is displayed at a time—any other faults that occur at the same time are prioritized internally. The "Next" button has no function
- Press "Enter" to call up the menu when warnings and faults occur. When the menu is exited, the last display to be shown reappears (display mode, warning, fault message)
- If the device is faulty, a corresponding fault message "Device defect // Error Code xxx" is displayed continuously. The buttons then have no function

Warnings

Fault message on the display	Green LED	Red LED	LED Qn	Description
Illuminate in sequence in the HMI	On	Off	Off	The device is initialized
Internal temperature high	On	dual flash	Normal	Measurement still possible—operation is outside the range
Internal temperature low	On	dual flash	Normal	Measurement still possible—operation is outside the range
CPU overloaded	On	dual flash	Normal	Too many Ethernet connections, scan resolution too high, etc.
Invalid IP configuration	On	dual flash	Normal	Invalid manual IP, no DHCP address received
IP address conflict	On	dual flash	Normal	Configured IP is already used in the network
Pre-fault warning	On	dual flash	Normal	Service life reached

Fault messages

Fault message on the display	Green LED	Red LED	LED Qn	Description
Internal temperature too high	On	On	Off	Internal temperature too high—no measurement possible Action: Allow device to cool down
Internal temperature too low	On	On	Off	Internal temperature too low—no measurement possible Action: Heat up device or allow it to heat up
Overload output Qx	Flashes 4 Hz	On	Normal	Short circuit or overload at Qx; Action: Eliminate the short circuit at the corresponding output or reduce load
Configuration	On	On	Off	Application data for field evaluation not valid; Action: Write data to the device again using DTM
Device defect // Error Code xx	Off	On	Off	The device is faulty; the customer is unable to repair the defect. Send the device with details of the error code

10 Appendix

10.1 Pulse Ranging Technology (PRT) Glossary

Term	Explanation
Accuracy	The degree to which the measurement result corresponds to the true value of the measurement. The accuracy is a relative error based on a measurement standard. For practical applications, a distinction is made between different influencing factors.
Absolute accuracy	The total of all systematic measurement errors (e.g., linearity, device offset) over a defined distance range, reflectivity range, and temperature range that cannot be eliminated by other actions such as average determination.
Repeat accuracy (repeatability)	The measurement is repeated on the same target and under the same conditions. The error is the repeatability value. The measured value noise is not taken into account.
Measured value noise	Randomly distributed deviation of a measured value by an average value. The distribution of the individual measurement values typically follows a statistical normal distribution.
Measuring range	The range between the smallest and largest object distance in which the measuring instrument supplies readings within the specification.

10.2 Using Open Source Programs

Pepperl+Fuchs uses a range of open source software in the R2000. These are the programs listed individually below from 1 to 12. We have edited programs 1 to 4:

1. U-Boot
2. Blackfin uClinux
3. Xenomai
4. Mongoose web server
5. Libedit
6. Giflib
7. Libncurses
8. ST standard peripherals library
9. ARM CMSIS header
10. IAR LIBC
11. AVR LIBC
12. CRC library

You may use all programs in accordance with the respective license. The licenses, their exact scope, and their exclusions of liability can be found in the header of the files themselves.

In accordance with the provisions of the licenses for programs 5 and 11, the respective copyright statements are reproduced here. The copyright statements can also be found in the relevant files.

Program no. 5: Libedit: Copyright (c) The Regents of the University of California.

Program no. 11: AVR LIBC: Portions of avr-libc are Copyright 1999 – 2005 (c) Keith Gudger, Bjoern Haase, Steinar Haugen, Peter Jansen, Reinhard Jessich, Magnus Johansson, Artur Lipowski, Marek Michalkiewicz, Colin O'Flynn, Bob Paddock, Reiner Patommel, Michael Rickman, Theodore A. Roth, Juergen Schilling, Philip Soeberg, Anatoly Sokolov, Nils Kristian Strom, Michael Stumpf, Stefan Swanepoel, Eric B. Weddington, Joerg Wunsch, Dmitry Xmelkov, The Regents of the University of California. Portions of avr-libc documentation Copyright (c) 1990, 1991, 1993, 1994 The Regents of the University of California.

We have reproduced the text of the license and exclusion of liability for programs no. 5 and no. 11:

"Redistribution and use in source and binary forms, with or without modification, are permitted provided that the following conditions are met:

*** Redistributions of source code must retain the above copyright notice, this list of conditions, and the following disclaimer.**

*** Redistributions in binary form must reproduce the above copyright notice, this list of conditions, and the following disclaimer in the documentation and/or other materials provided with the distribution.**

*** Neither the name of the copyright holders nor the names of contributors may be used to endorse or promote products derived from this software without specific prior written permission.**

THIS SOFTWARE IS PROVIDED BY THE COPYRIGHT HOLDERS AND CONTRIBUTORS "AS IS" AND ANY EXPRESS OR IMPLIED WARRANTIES, INCLUDING, BUT NOT LIMITED TO, THE IMPLIED WARRANTIES OF MERCHANTABILITY AND FITNESS FOR A PARTICULAR PURPOSE ARE DISCLAIMED. IN NO EVENT SHALL THE COPYRIGHT OWNER OR CONTRIBUTORS BE LIABLE FOR ANY DIRECT, INDIRECT, INCIDENTAL, SPECIAL, EXEMPLARY, OR CONSEQUENTIAL DAMAGES (INCLUDING, BUT NOT LIMITED TO, PROCUREMENT OF SUBSTITUTE GOODS OR SERVICES; LOSS OF USE, DATA, OR PROFITS; OR BUSINESS INTERRUPTION) HOWEVER CAUSED AND ON ANY THEORY OF LIABILITY, WHETHER IN CONTRACT, STRICT LIABILITY, OR TORT (INCLUDING NEGLIGENCE OR OTHERWISE) ARISING IN ANY WAY OUT OF THE USE OF THIS SOFTWARE, EVEN IF ADVISED OF THE POSSIBILITY OF SUCH DAMAGE."

Programs 1, 2, and 3 are licensed in accordance with the GNU General Public License v2. Program 3 is additionally licensed for the **user space** in accordance with the Lesser General Public License. Pepperl+Fuchs grants you and any third party a free license for further processing in accordance with the GNU General Public License v2 and/or the Lesser General Public License.

Pepperl+Fuchs offers to provide you and any third party with the **source code** for programs 1, 2, and 3 in the form in which we developed it for a period of three years from distribution by Pepperl+Fuchs, free of charge on a read/write tag commonly used for exchanging software.

Pepperl+Fuchs is not liable for any changes made to the open source software by the user.

Your automation, our passion.

Explosion Protection

- Intrinsic Safety Barriers
- Signal Conditioners
- FieldConnex® Fieldbus
- Remote I/O Systems
- Electrical Ex Equipment
- Purge and Pressurization
- Industrial HMI
- Mobile Computing and Communications
- HART Interface Solutions
- Surge Protection
- Wireless Solutions
- Level Measurement

Industrial Sensors

- Proximity Sensors
- Photoelectric Sensors
- Industrial Vision
- Ultrasonic Sensors
- Rotary Encoders
- Positioning Systems
- Inclination and Acceleration Sensors
- Fieldbus Modules
- AS-Interface
- Identification Systems
- Displays and Signal Processing
- Connectivity

Pepperl+Fuchs Quality

Download our latest policy here:

www.pepperl-fuchs.com/quality

