

Betriebsanleitung
Instruction manual
Notice d'instructions

Pulscon

LTC57

PROFIBUS PA

**ATEX: II 1D Ex ta IIIC T₅₀₀ xx°C Da
II 1/2D Ex ta IIIC Txx°C Da/Db**

**IECEX: Ex ta IIIC T₅₀₀ xx°C Da
Ex ta IIIC Txx°C Da/Db**



SI005210-C

DE – Sicherheitshinweise für elektrische Betriebsmittel für explosionsgefährdete Bereiche, siehe Seite 5

EN – Safety instructions for electrical apparatus for explosion-hazardous areas, see page 11

FR – Conseils de sécurité pour matériels électriques destinés aux zones explosibles, regardez à la page 17

SI005210-C/98/A3/15.13
71239678

bg - Правила за техниката на безопасност за електрически средства за производство във взривоопасни зони. Ако не разбирате езика на това ръководство има възможност да си поръчате при нас едно ръководство, преведено на езика на Вашата страна

Заявление за съответствие с EG

Производителят Pepperl+Fuchs декларира с това заявление за съответствие и с предявяването на сертификата CE, че този продукт отговаря на изискванията на съответните европейски директиви. Прилаганите директиви, норми и документи са указани в заявлението за съответствие

cs - Bezpečnostní pokyny pro elektrické přístroje v místech s nebezpečím výbuchu. Pokud nemáte možnost přečíst si tento návod, můžete si u nás objednat návod přeložený do svého jazyka.

Prohlášení o shodě s ES

Společnost Pepperl+Fuchs prohlašuje prostřednictvím tohoto prohlášení a použitím značky CE, že tento výrobek vyhovuje příslušným evropským směrnici. Zmíněné směrnice, normy a dokumenty jsou uvedeny v Prohlášení o shodě.

da - Sikkerhedsforskrifter for elektriske apparater certificeret til brug i eksplosionsfarlige områder. Hvis du ikke forstår denne manual, kan en oversat kopi af den på dit eget sprog bestilles fra os.

EF-overensstemmelseserklæring

Med denne overensstemmelseserklæring og tilføjelsen af CE-mærket sikrer producenten Pepperl+Fuchs, at produktet er i overensstemmelse med relevante europæiske direktiver. Dokumentation for overensstemmelsen gives i de anførte direktiver, standarder og dokumenter.

el - Οδηγίες ασφαλείας ηλεκτρικών συσκευών για επικίνδυνες για έκρηξη περιοχές. Σε περίπτωση που δεν μπορείτε να διαβάσετε αυτές τις οδηγίες, τότε μπορείτε να παραγγείλετε ένα αντίστοιχο μεταφρασμένο στη γλώσσα σας.

Δήλωση πιστότητας ΕΚ

Με αυτή τη δήλωση πιστότητας και την τοποθέτηση του σήματος CE ο κατασκευαστής Pepperl+Fuchs δηλώνει, ότι αυτό το προϊόν συμμορφώνεται με τις ευρωπαϊκές οδηγίες που πρέπει να εφαρμοστούν. Οι οδηγίες, τα πορότυπα και τα έγγραφα που εφαρμόστηκαν αναφέρονται στη δήλωση πιστότητας.

es - Instrucciones de seguridad de aparatos eléctricos homologados para su utilización en áreas expuestas a riesgos de deflagración. Si no entiende este manual, puede pedir un ejemplar en su idioma.

Declaración de conformidad CE

Por la presente declaración y la inclusión de la marca CE, el fabricante Pepperl+Fuchs, declara que el producto cumple con las directivas europeas pertinentes. Las directivas, normas y documentos de aplicación se indican en la declaración de conformidad.

et - Ohutusjuhised plahvatusohtlikus keskkonnas kasutatavate elektriseadmete kohta. Kui Te ei saa käesolevast juhendist aru, võite meilt tellida Teie riigikeelde tõlgitud juhendi.

EL vastavusdeklaratsioon

Tootja Pepperl+Fuchs kinnitab juurdelisatud vastavusdeklaratsiooniga esitamise ja CE-märgise kandmise tootele, et käesolev toode vastab kohaldatavate Euroopa Liidu direktiivide nõuetele. Kohaldatavad direktiivid, standardid ja dokumendid on ära toodud vastavusdeklaratsioonis.

fi - Turvallisuusohjeita sähkölaitteille, jotka on vahvistettu käytettäväksi räjähdysvaarallisilla alueilla. Jos et ymmärrä tätä käsikirjaa, voit tilata meiltä käänöksen omalla kansallisella kielelläsi.

EU-vaatimustenmukaisuustodistus

Valmistaja Pepperl+Fuchs vakuuttaa täällä vaatimustenmukaisuustodistuksella ja CE-merkin kiinnittämisellä, että tämä tuote täyttää sovellettavien EU-direktiivien määräykset. Sovellettavat direktiivit, normit ja dokumentit on merkitty vaatimustenmukaisuustodistukseen.

hu - Biztonsági információk robbanásveszélyes területre való elektromos eszközökhöz. Amennyiben nem tudja elolvasni ezt az útmutatót, akkor megrendelheti az Ön anyanyelvére lefordítva is.

EK-megfelelőségi nyilatkozat

Az Pepperl+Fuchs mint gyártó jelen megfeleléségi nyilatkozattal és a CE-jelzés felhelyezésével kijelenti, hogy ez a termék megfelel az alkalmazandó európai irányelveknek. Az alkalmazott irányelvek, szabványok és dokumentumok a megfeleléségi nyilatkozatban fel vannak tüntetve.

it - Istruzioni di sicurezza per apparecchiature elettriche certificate per l'utilizzo in aree con pericolo di esplosione. Se il presente manuale non risulta comprensibile potete ordinarne una copia tradotta nella vostra lingua.

Dichiarazione di conformità CE

Con questa dichiarazione e con l'applicazione del marchio CE, il costruttore Pepperl+Fuchs, assicura che il prodotto è conforme alle direttive europee vigenti. Prova della conformità è fornita dall'osservanza delle direttive, delle norme e dei documenti elencati.

lt - Elektros įrenginio saugumo nurodymai, susiję su sprogimo zonomis. Jeigu negalite perskaityti šios instrukcijos, kreipkitės į mus, kad užsisakytumėte į jūsų gimtąją kalbą išverstą instrukciją.

EB atitikties deklaracija

Gamintojas Pepperl+Fuchs šia atitikties deklaracija ir CE ženkliniu patvirtina, kad gaminys atitinka taikytinas ES direktyvas. Taikomos direktyvos, normos ir dokumentai yra pateikiami atitikties deklaracijoje.

lv - Drošības norādījumi elektrisko darba instrumentu lietošanai apgabalos, kas pakļauti sprādzienbīstāmībai. Ja Jums nav iespēju izlasīt šos norādījumus, Jūs varat pasūtīt pie mums tulkojumu Jūsu valsts valodā.

ES atbilstības apliecinājums

Ražotājs Pepperl+Fuchs ar šo atbilstības apliecinājumu un CE zīmola lietojumu apstiprina, ka produkts izgatavots saskaņā ar atbilstošajām Eiropas vadlīnijām. Piemērotās vadlīnijas, normas un dokumentātrunāt atbilstības apliecinājumā.

nl - Veiligheidsinstructies voor elektrisch materieel in explosiegevaarlijke omgeving. Wanneer u deze handleiding niet kunt lezen, kunt u een in uw landstaal vertaalde handleiding bij ons bestellen.

EG Conformiteitsverklaring

De leverancier Pepperl+Fuchs waarborgt met deze verklaring en het aanbrengen van het CE-teken, dat dit product overeenstemt met de geldende Europese richtlijnen. De geldende richtlijnen, normen en documenten zijn aangegeven in de conformiteitsverklaring.

pl - Wskazówki dot. bezpieczeństwa dla urządzeń elektrycznych stosowanych w obszarze zagrożonym wybuchem. Jeśli niniejsza instrukcja napisana jest w języku, którym się nie posługujesz, możesz zamówić u nas przetłumaczony dokument.

Deklaracja zgodności WE

Producent Pepperl+Fuchs w niniejszej deklaracji zgodności wraz z nadaniem znaku CE oświadcza, że produkt ten jest zgodny z obowiązującą Europejską Dyrektywą. Zastosowane wytyczne, normy oraz dokumenty podane są w deklaracji zgodności

pt - Instruções de segurança para dispositivos eléctricos certificados para utilização em áreas de risco de incêndio. Se não compreender este manual, pode encomendar-nos directamente uma cópia na sua língua.

Declaração de conformidade CE

Com esta declaração de conformidade e a aplicação da marca CE, o fabricante Pepperl+Fuchs, garante que o produto obedece às directivas europeias a aplicar. As directivas, normas e documentos são apresentadas na declaração de conformidade.

ro - Indicații de siguranță pentru mijloacele de producție electrice pentru zonele periculoase de explozie. Dacă nu puteți citi aceste instrucțiuni, atunci puteți comanda la noi instrucțiunile traduse în limba țării dumneavoastră.

Declarație de conformitate CE

Producătorul Pepperl+Fuchs declară prin declarația de conformitate alăturată și prin aplicarea semnului CE că acest produs corespunde directivelor europene aplicabile. Directivele, normele aplicate și documentele sunt menționate în declarația de conformitate.

sk - Bezpečnostné pokyny pre elektrické zariadenie prevádzkované v priestoroch nebezpečenstvom výbuchu. Ak nemáte možnosť prečítať si tento návod, môžete si u nás objednať návod preložený do svojho jazyka.

Vyhlasenie o konformite s ES

Spoločnosť Pepperl+Fuchs vyhlasuje prostredníctvom tohto vyhlásenia o konformite a použitím značky CE, že tento výrobok vyhovuje príslušným európskym smerniciam. Zmieňované smernice, normy a dokumenty sú uvedené vo Vyhlasení o konformite.

sl - Varnostni napotki glede električne opreme, namenjene za uporabo v eksplozivnih območjih. Če teh navodil ne morete razumeti, lahko pri nas naročite prevod v vaš jezik.

Pojasnilo glede potrdila o skladnosti EU

Proizvajalec Pepperl+Fuchs s to izjavo o skladnosti in navedbo oznake CE izjavlja, da je ta izdelek skladen s predpisanimi evropskimi smernicami. Upoštewane smernice, standardi in dokumenti so navedeni v izjavi o skladnosti.

sv - Säkerhetsföreskrifter för elektrisk utrustning certifierad för användning i explosionsfarliga områden. Om du inte förstår denna manual, kan en översatt kopia på ditt eget språk beställas från oss.

EG-försäkran om överensstämmelse

Pepperl+Fuchs försäkrar med vidstående försäkran om överensstämmelse och med CE-märkningen att denna produkt överensstämmer med de tillämpbara europeiska riktlinjerna. De tillämpade riktlinjerna, normerna och dokumenten anges i försäkran om överensstämmelse.

EU-Konformitätserklärung/EU-Declaration of conformity/
Déclaration UE de conformité

EU-Declaration of conformity

en/de

EU-Konformitätserklärung

Pepperl+Fuchs GmbH
Lilienthalstraße 200
68307 Mannheim
Germany
Phone +49 621 776-0
Fax +49 621 776-1000

No. / Nr.: DOC-0091A
Date / Datum: 2015-03-26

Copyright Pepperl+Fuchs
www.pepperl-fuchs.com

PF PEPPERL+FUCHS

Declaration of conformity / Konformitätserklärung

We, Pepperl+Fuchs GmbH declare under our sole responsibility that the products listed below are in conformity with the listed European Directives and standards.

Die Pepperl+Fuchs GmbH erklärt hiermit in alleiniger Verantwortung, dass die unten gelisteten Produkte den genannten Europäischen Richtlinien und Normen entsprechen.

Productfamily / Produktfamilie

Productfamily / Produktfamilie	Description / Beschreibung
LTC50-X-XXXXX-XXXXX-XX	Pulscan Guided Microwave
LTC51-X-XXXXX-XXXXX-XX	Pulscan Guided Microwave
LTC57-X-XXXXX-XXXXX-XX	Pulscan Guided Microwave

The „X“ marked letters of the type code are placeholders and can be replaced by the code described in ANNEX TYPE CODE.
Die mit „X“ markierten Stellen im Typenschlüssel sind Platzhalter und können durch den Schlüssel ersetzt werden der in ANNEX TYPE CODE beschrieben ist.

ANNEX TYPE CODE

The „X“ marked letters of the type code are placeholders and can be replaced by the following code:
Die mit „X“ markierten Stellen im Typenschlüssel sind Platzhalter und können durch folgenden Schlüssel ersetzt werden:

LTC50-X-XXXXX-XXXXX-XX								
LTC50	-X	-XXX	X	X	-XX	XX	X	-XX
Product family	Probe version	Process Connection	Electrical connection	Sealing	Housing	Electrical Output IH, ID, IE, PA, DH	Display	Certificates Options E1, EX, ED, SX, EG, EW
LTC51-X-XXXXX-XXXXX-XX								
LTC51	-X	-XXX	X	X	-XX	XX	X	-XX
Product family	Probe version	Process Connection	Electrical connection	Sealing	Housing	Electrical Output IH, ID, IE, PA, DH	Display	Certificates Options E1, EX, ED, E2, SX, EG, EW
LTC57-X-XXXXX-XXXXX-XX								
LTC57	-X	-XXX	X	X	-XX	XX	X	-XX
Product family	Probe version	Process Connection	Electrical connection	Sealing	Housing	Electrical Output IH, ID, IE, PA, DH	Display	Certificates Options E1, EX, S3, S4, SX, EG

Directives and Standards / Richtlinien und Normen

EU-Directive EU-Richtlinie	Standards Normen
2004/108/EC (EMC)	EN 61326-1:2006 EN 61326-2-3:2006
94/9/EC (ATEX)	EN 60079-0:2012 EN 60079-1:2007 EN 60079-11:2012 EN 60079-26:2007 EN 60079-31:2009

Affixed CE Marking / Angebrachte CE-Kennzeichnung



Signatures / Unterschriften

Mannheim, 2015-03-26

ppa. Lutz Liebers
Vice President Sales

i.V. Martin Holdefer
Business Development Manager

ANNEX 94/9/EC (ATEX)

Notified Body QM-System / Notifizierte Stelle des QM-Systems:
Physikalisch Technische Bundesanstalt (0102)
Bundesallee 100
38116 Braunschweig, Germany

Marking and Certificates / Kennzeichnung und Zertifikate

Products / Produkte	All products listed above (depending on ordering option) / Alle oben gelisteten Produkte (abhängig von Bestelloption)	
Marking Kennzeichnung	Certificate Zertifikat	Issuer ID Aussteller ID
⊕ II 1 G ⊕ II 1/2 G ⊕ II 1/3 G ⊕ II 1 D ⊕ II 1/2 D	DEKRA 14 ATEX 0117 X	0344

Key for Issuer ID / Schlüssel zur Aussteller ID

ID	Issuer / Aussteller
0344	DEKRA Certification B.V. Meander 1051 6825 MJ Arnheim Netherlands





Pulscon **LTC57**

PROFIBUS PA

Table of Contents

Associated documentation	12
Supplementary documentation	12
Manufacturer's certificates	12
Extended order code	12
Safety instructions: General	13
Safety instructions: Special conditions	13
Safety instructions: Installation	14
Temperature tables	14
Connection data	15

EN

Associated documentation

This document is an integral part of the following Operating Instructions:
BA01009O
The Operating Instructions pertaining to the device apply.

Supplementary documentation

Explosion-protection manual

Manufacturer's certificates

EU-Declaration of conformity

see page 3

EC type-examination certificate

Certificate number:
DEKRA 14 ATEX 0117X

IEC Declaration of conformity

Certificate number:
IECEX DEK 14.0066X

Affixing the certificate number certifies conformity with the standards under www.IECEX.com (depending on the device version).

- IEC 60079-0:2011
- IEC 60079-11:2011
- IEC 60079-31:2008

Extended order code

The extended order code is indicated on the nameplate, which is affixed to the device in such a way that it is clearly visible. Additional information about the nameplate is provided in the associated Operating Instructions.

Structure of the extended order code

Device type		Basic specifications		Optional specifications
LTC5X	-	X-XXXXX-XXXXX-XX XXXXX	+	XXXXXXXXXX

X = Placeholder

At this position, an option (number or letter) selected from the specification is displayed instead of the placeholders.

Basic specifications

The features that are absolutely essential for the device (mandatory features) are specified in the basic specifications. The number of positions depends on the number of features available.

The selected option of a feature can consist of several positions.

Optional specifications

The optional specifications describe additional features for the device (optional features). The number of positions depends on the number of features available.

More detailed information about the device is provided in the following tables. These tables describe the individual positions and IDs in the extended order code which are relevant to hazardous locations.

EN

Basic specifications

Selected Option	Position	Description
Approval	LTC57-X-XXXXX-XXXXX- XX XXXXX	S3 ATEX II 1D Ex ta IIIC T ₅₀₀ ^{XX} °C Da
		S4 ATEX II 1/2D Ex ta IIIC T _{XX} °C Da/Db
		IE IECEx Ex ta IIIC T ₅₀₀ ^{XX} °C Da
		IF IECEx Ex ta IIIC T _{XX} °C Da/Db
Electrical output	LTC57-X-XXXXX- XX XX-XX XXXXX	PA 2-wire, PROFIBUS PA, switch output (PFS)
Display, operation	LTC57-X-XXXXX-XXXX X -XX XXXXX	B without display, via communication
		D SD02, 4-line, push-buttons and data backup function
		E SD03, 4-line, illuminated, touch control and data backup function
Housing	LTC57-X-XXXXX- XX XX-XX XXXXX	A2 GT20 dual compartment, alu coated
		A3 GT18 dual compartment, 316L
Seal	LTC57-X-XXXX X -XXXXX-XX XXXXX	3 EPDM, -40 °C ... 120 °C
		5 Viton, -30 °C ... 150 °C

Optional specifications

Selected Option	Position	Description
Probe design	XXXXXX X XXX	B Sensor remote, 3 m cable, detachable, with mounting bracket

Safety instructions:
General

- Staff must meet the following conditions for mounting, electrical installation, commissioning and maintenance of the device:
 - Be suitably qualified for their role and the tasks they perform
 - Be trained in explosion protection
 - Be familiar with national regulations (e. g. IEC/EN 60079-14)
- Install the device according to the manufacturer's instructions and national regulations.
- Do not operate the device outside the specified electrical, thermal and mechanical parameters.
- Only use the device in media to which the wetted materials have sufficient durability.
- Avoid electrostatic charging:
 - Of plastic surfaces (e. g. housing, sensor element, special varnishing , attached additional plates, ...)
 - Of isolated capacities (e. g. isolated metallic plates)
- Refer to the temperature tables for the relationship between the permitted ambient temperature for the sensor and/or transmitter, depending on the range of application, and the temperature class.
- Modifications to the device can affect the explosion protection and must be carried out by staff authorized to perform such work by Pepperl+Fuchs.
- When replacing the probe electronics or opening the connection between the remote cable and the probe, a jumper plug must be used or a short-circuit must be established between the probe contact and the potential equalization conductor to avoid electrostatically charging the probe.
- After mounting and connecting the probe, ingress protection of the housing must be at least IP65 in accordance with EN 60529.
Perform the following to achieve the degree of protection:
 - Screw the cover tight.
 - Mount the cable entry correctly.

Safety instructions:
Special conditions

- Permitted ambient temperature range at the electronics housing: $-40\text{ °C} \leq T_{\text{amb}} \leq +80\text{ °C}$.
Observe the information in the temperature tables.
- In the case of process connections made of polymeric material or with polymeric coatings, avoid electrostatic charging of the plastic surfaces.
 - In the event of additional or alternative special varnishing on the housing or other metal parts:
 - Observe the danger of electrostatic charging and discharge.
 - Do not rub surfaces with a dry cloth.

EN

Safety instructions:
Installation

EN

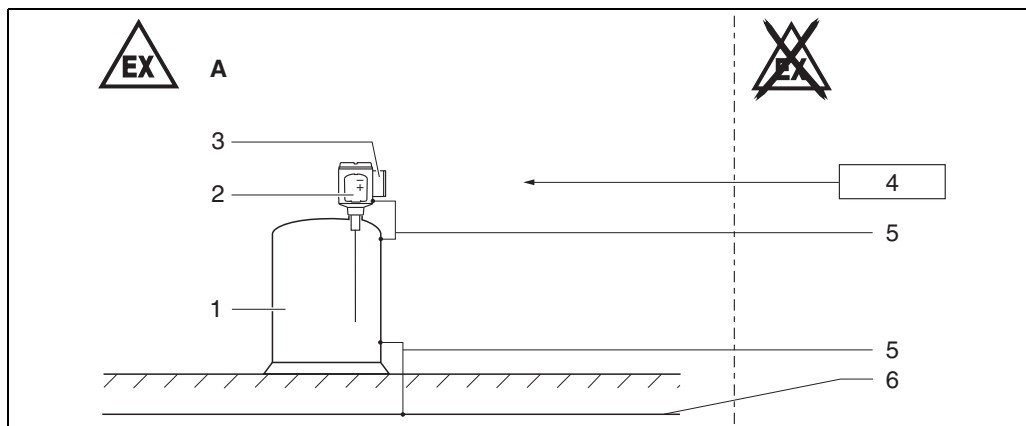

Figure 1

A Zone 20, Zone 21

- 1 Tank; Zone 20, Zone 21
- 2 Electronics compartment Ex iaD; Electronic insert
- 3 Connection compartment Ex t
- 4 Power supply
- 5 Potential equalization line
- 6 Potential equalization

- After aligning (rotating) the housing, retighten the fixing screw (see Operating Instructions).
- When mounting the device:
 - Exclude any mechanical damage or friction during the application.
 - Pay particular attention to flow conditions and tank fittings.
- Continuous service temperature of the connecting cable: $-40\text{ °C} \dots \geq +85\text{ °C}$; in accordance with the range of service temperature taking into account additional influences of the process conditions ($T_{\text{amb, min}}$), ($T_{\text{amb, max}} + 20\text{ K}$).
- Only use certified cable entries or sealing plugs.
The metal sealing plugs supplied meet this requirement.
- Before operation:
 - Screw in the cover all the way.
 - Tighten the securing clamp on the cover.

Intrinsic safety

- The device can be connected to a service interface. Refer to the Operating Instructions

Temperature tables

see page 23

Connection data

Basic specification, option "Approval" = S3, S4, IE, IF

Connection compartment Ex t

The power consumption of I/O modules with passive PFS output can be limited for certain applications.

- Recommended: Power consumption = 1 W.
This is obtained for a supply voltage at the terminals of 27 V DC.
- For higher supply voltages (U_{max}): Insert a serial resistance (R_V) in order to limit the power consumption, see table below.

Table for the PFS serial resistance (RV)

Power consumption	1.0 W
Total power consumption	1.88 W
Internal resistance R_i	760 Ω

U_{max} [V]	R_V min
35	205 Ω
34	177 Ω
33	150 Ω
32	122 Ω
31	95 Ω
30	67 Ω
29	39 Ω
28	12 Ω
27	0 Ω

Note!

For values associated with a higher or lower internal power consumption please contact Pepperl+Fuchs.

Basic specification, Option "Electrical output" = PA (TRC [27])

Terminal 1 (+), 2 (-)	Terminal 3 (+), 4 (-)
Power supply: $U_N = 32$ V DC $U_m = 250$ V AC	Switch output (PFS): $U_N = 35$ V DC $U_m = 250$ V AC

Electronics compartment Ex i

Service interface (CDI)

Taking the following values into consideration, the device can be connected to the certified service tool or a similar interface:

Service interface												
$U_i = 7.3$ V												
effective inner inductance $L_i =$ negligible												
effective inner capacitance $C_i =$ negligible												
$U_o = 7.3$ V												
$I_o = 100$ mA												
$P_o = 160$ mW												
L_o (mH) =	5.00	2.00	1.00	0.50	0.20	0.10	0.05	0.02	0.01	0.005	0.002	0.001
C_o (μ F) =	0.73	1.20	1.60	2.00	2.60	3.20	4.00	5.50	7.30	10.00	12.70	12.70



EN



Temperaturtabellen/Temperature tables/ Tableaux des températures

Inhaltsverzeichnis/Table of Contents/Sommaire

Allgemeine Hinweise/General notes/Généralités	24
Tabellen/Tables/Tableaux	
Sonde und Elektronikgehäuse/Probe and electronics housing/Sonde et boîtier de l'électronique : Zone 20, Zone 21	
LTC57	25

Allgemeine Hinweise

Wenn nicht anders angegeben, beziehen sich die Positionen immer auf die Grundspezifikation.

T_{amb} = Umgebungstemperatur

T_{500} = Einschüttung mit einer Schichtdicke von 500 mm

Auswahltabelle

Zulassung		Gehäuse	
S3	ATEX II 1D Ex ta IIIC $T_{500}^{xx}C$ Da	A2	GT20 Zweikammer, Alu beschichtet
S4	ATEX II 1/2D Ex ta IIIC $T_{xx}C$ Da/Db	A3	GT18 Zweikammer, 316L
IE	IECEX Ex ta IIIC $T_{500}^{xx}C$ Da		
IF	IECEX Ex ta IIIC $T_{xx}C$ Da/Db		

Elektrischer Ausgang		Transmission-Code des Anschlussklemmenmoduls		Kanäle
PA	2-Draht, Schaltausgang (PFS)	TRC [27], TRC [07] ¹		1 oder 2 Kanäle benutzt

¹ siehe Typenschild

General notes

Unless otherwise indicated, the positions always refer to the basic specification.

T_{amb} = Ambient temperature

T_{500} = Deposited material with a layer of 500 mm

Selection table

Approval		Housing	
S3	ATEX II 1D Ex ta IIIC $T_{500}^{xx}C$ Da	A2	GT20 dual compartment, Alu coated
S4	ATEX II 1/2D Ex ta IIIC $T_{xx}C$ Da/Db	A3	GT18 dual compartment, 316L
IE	IECEX Ex ta IIIC $T_{500}^{xx}C$ Da		
IF	IECEX Ex ta IIIC $T_{xx}C$ Da/Db		

Electrical output		Transmission code of the terminal module		Channels
PA	2-wire, switch output (PFS)	TRC [27], TRC [07] ¹		1 or 2 channels used

¹ see nameplate

Généralités

Sauf indication contraire, les positions se réfèrent toujours aux spécifications de base.

T_{amb} = Température ambiante

T_{500} = Enfouissement sous couche de 500 mm d'épaisseur

Tableau de sélection

Agrément		Boîtier	
S3	ATEX II 1D Ex ta IIIC $T_{500}^{xx}C$ Da	A2	GT20 double compartiment, alu revêtu
S4	ATEX II 1/2D Ex ta IIIC $T_{xx}C$ Da/Db	A3	GT18 double compartiment, 316L
IE	IECEX Ex ta IIIC $T_{500}^{xx}C$ Da		
IF	IECEX Ex ta IIIC $T_{xx}C$ Da/Db		

Sortie électrique		Code de transmission du module de raccordement		Voies
PA	2-fils, sortie tout ou rien (PFS)	TRC [27], TRC [07] ¹		1 ou 2 voies utilisées

¹ voir plaque signalétique



Tabellen/Tables/Tableaux Sonde und Elektronikgehäuse/Probe and electronics housing/Sonde et boîtier de l'électronique : Zone 20, Zone 21

LTC57

Elektrischer Ausgang/Electrical output/Sortie électrique= PA (TRC [27])

Gehäuse/Housing/Boîtier = A2, A3

1 Kanal benutzt/1 channel used/1 voie utilisée	2 Kanäle benutzt/2 channeles used/2 voies utilisées
$T = T_{amb} + 5 \text{ K}$ $T_{500} = T_{amb} + 19 \text{ K}$	$T = T_{amb} + 20 \text{ K}$ $T_{500} = T_{amb} + 40 \text{ K}$



With regard to the supply of products, the current issue of the following document is applicable: The General Terms of Delivery for Products and Services of the Electrical Industry, published by the Central Association of the "Elektrotechnik und Elektroindustrie (ZVEI) e.V." including the supplementary clause: "Erweiterter Eigentumsvorbehalt".

PROCESS AUTOMATION – PROTECTING YOUR PROCESS



Worldwide Headquarters

Pepperl+Fuchs GmbH
68307 Mannheim · Germany
Tel. +49 621776-0
E-mail: info@de.pepperl-fuchs.com

For the Pepperl+Fuchs representative
closest to you check www.pepperl-fuchs.com/pfcontact

www.pepperl-fuchs.com

Subject to modifications
Copyright Pepperl+Fuchs • Printed in Germany



SI00521O-C/98/A3/15.13
FM7.2

 **PEPPERL+FUCHS**
PROTECTING YOUR PROCESS

DOCT-3756

269420
04/2015