

## QUICK START GUIDE

# Pulscon LTC51 PROFIBUS PA Guided Level Radar Level measurement in liquids



**SIL3**



With regard to the supply of products, the current issue of the following document is applicable: The General Terms of Delivery for Products and Services of the Electrical Industry, published by the Central Association of the Electrical Industry (Zentralverband Elektrotechnik und Elektroindustrie (ZVEI) e.V.) in its most recent version as well as the supplementary clause: "Expanded reservation of proprietorship".

These Instructions are Quick Start Guides; they are not a substitute for the Operating Instructions pertaining to the device.

Detailed information about the device can be found in the Operating Instructions and the other documentation via internet [www.pepperl-fuchs.com](http://www.pepperl-fuchs.com).

The complete device documentation consists of:

- these Quick Start Guide
- the Operating Instructions
- the Technical Information

|          |   |           |
|----------|---|-----------|
| <b>1</b> | <b>Important document information</b>                 | <b>5</b>  |
| 1.1      | Symbols   | 5         |
| <b>2</b> | <b>Basic safety instructions</b>                      | <b>8</b>  |
| 2.1      | Requirements for the personnel                        | 8         |
| 2.2      | Designated use  | 8         |
| 2.3      | Workplace safety                                      | 9         |
| 2.4      | Operational safety                                    | 9         |
| 2.5      | Product safety  | 10        |
| <b>3</b> | <b>Product description</b>                            | <b>11</b> |
| 3.1      | Design  | 11        |
| <b>4</b> | <b>Incoming acceptance and product identification</b> | <b>13</b> |
| 4.1      | Incoming acceptance                                   | 13        |
| 4.2      | Product identification                                | 14        |
| 4.3      | Device documentation                                  | 15        |
| <b>5</b> | <b>Storage, Transport</b>                             | <b>16</b> |
| 5.1      | Storage conditions                                    | 16        |
| 5.2      | Transport product to the measuring point              | 16        |
| <b>6</b> | <b>Mounting</b>                                       | <b>17</b> |
| 6.1      | Mounting requirements                                 | 17        |
| 6.2      | Mounting the device                                   | 32        |
| 6.3      | Post-installation check                               | 42        |
| <b>7</b> | <b>Electrical connection</b>                          | <b>43</b> |
| 7.1      | Connection conditions                                 | 43        |
| 7.2      | Connecting the device                                 | 48        |
| 7.3      | Post-connection check                                 | 51        |

|          |   |           |
|----------|---|-----------|
| <b>8</b> | <b>Integration into a PROFIBUS network</b>  | <b>52</b> |
| 8.1      | Overview of the device database files (GSD) | 52        |
| 8.2      | Set device address                          | 52        |
| <b>9</b> | <b>Commissioning (via operating menu)</b>   | <b>54</b> |
| 9.1      | Display and operating module                | 54        |
| 9.2      | Operating menu                              | 57        |
| 9.3      | Unlock the device                           | 57        |
| 9.4      | Setting the operating language              | 58        |
| 9.5      | Configuration of a level measurement        | 59        |
| 9.6      | User-specific applications                  | 61        |

# 1 Important document information

## 1.1 Symbols

### 1.1.1 Used Symbols

This document contains information that you must read for your own personal safety and to avoid property damage. Depending on the risk level, the warning messages are displayed in descending order as follows:

#### Safety-Relevant Symbols



##### ***Danger!***

This symbol indicates an imminent danger.

Non-observance will result in personal injury or death.



##### ***Warning!***

This symbol indicates a possible fault or danger.

Non-observance may cause personal injury or serious property damage.



##### ***Caution!***

This symbol indicates a possible fault.

Non-observance could interrupt the device and any connected systems and plants, or result in their complete failure.

#### Informative Symbols



##### ***Note!***

This symbol brings important information to your attention.



##### Action

This symbol indicates a paragraph with instructions.

### 1.1.2 Electrical symbols







| Symbol  | Meaning  |
|---|--|
|  | <b>Direct current</b><br>A terminal to which DC voltage is applied or through which direct current flows.  |
|  | <b>Alternating current</b><br>A terminal to which alternating voltage is applied or through which alternating current flows.   |
|  | <b>Direct current and alternating current</b> <ul style="list-style-type: none"> <li>• A terminal to which alternating voltage or DC voltage is applied.</li> <li>• A terminal through which alternating current or direct current flows.</li> </ul> |
|  | <b>Ground connection</b><br>A grounded terminal which, as far as the operator is concerned, is grounded via a grounding system.  |
|  | <b>Protective ground connection</b><br>A terminal which must be connected to ground prior to establishing any other connections.   |
|  | <b>Equipotential connection</b><br>A connection that has to be connected to the plant grounding system: This may be a potential equalization line or a star grounding system depending on national or company codes of practice.                     |

Table 1.1

### 1.1.3 Tool symbols





| Symbol  | Meaning                |
|---|------------------------|
|    | Torx screwdriver       |
|   | Flat blade screwdriver |
|  | Cross-head screwdriver |
|  | Allen key              |
|  | Hexagon wrench         |

Table 1.2

### 1.1.4 Symbols for certain types of information





| Symbol  | Meaning  |
|---|--|
|  | <b>Allowed</b><br>Indicates procedures, processes or actions that are allowed.     |
|  | <b>Preferred</b><br>Indicates procedures, processes or actions that are preferred. |
|  | <b>Forbidden</b><br>Indicates procedures, processes or actions that are forbidden. |
| 1., 2., 3. ...  | Series of steps  |
|  | Result of a sequence of actions  |
|  | Visual check   |

Table 1.3

### 1.1.5 Symbols in graphics



| Symbol  | Meaning  |
|---|--|
| 1, 2, 3 ...   | Item numbers   |
|  | Series of steps  |
| A, B, C, ...  | Views  |
| A-A, B-B, C-C, ...  | Sections   |
|  | <b>Hazardous area</b><br>Indicates a hazardous area.                         |
|  | <b>Safe area (non-hazardous area)</b><br>Indicates a non-hazardous location. |

Table 1.4

### 1.1.6 Symbols at the device

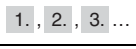

| Symbol  | Meaning   |
|---|---|
|  | <b>Safety instructions</b><br>Observe the safety instructions contained in the associated Operating Instructions.                             |
|  | <b>Temperature resistance of the connection cables</b><br>Specifies the minimum value of the temperature resistance of the connection cables. |

Table 1.5

## 2 Basic safety instructions

### 2.1 Requirements for the personnel

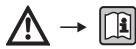
The personnel for installation, commissioning, diagnostics and maintenance must fulfill the following requirements:

- Trained, qualified specialists must have a relevant qualification for this specific function and task
- Are authorized by the plant owner/operator
- Are familiar with federal/national regulations
- Before beginning work, the specialist staff must have read and understood the instructions in the Operating Instructions and supplementary documentation as well as in the certificates (depending on the application)
- Following instructions and basic conditions

The operating personnel must fulfill the following requirements:

- Being instructed and authorized according to the requirements of the task by the facility's owner-operator
- Following the instructions in these Operating Instructions

### 2.2 Designated use

#### Application and measured materials

The measuring device described in these Operating Instructions is intended only for level measurement of liquids. Depending on the version ordered the device can also measure potentially explosive, flammable, poisonous and oxidizing materials.

Observing the limit values specified in the "Technical data" and listed in the Operating Instructions and supplementary documentation, the measuring device may be used for the following measurements only:

- Measured process variable: Level
- Calculated process variables: Volume or mass in arbitrarily shaped vessels (calculated from the level by the linearization functionality)

To ensure that the measuring device remains in proper condition for the operation time:

- Use the measuring device only for measured materials against which the process-wetted materials are adequately resistant.
- Observe the limit values in "Technical data".



### **Incorrect use**

The manufacturer is not liable for damage caused by improper or non-designated use.

Verification for borderline cases:

- For special measured materials and cleaning agents, Pepperl+Fuchs is glad to provide assistance in verifying the corrosion resistance of wetted materials, but does not accept any warranty or liability.

### **Residual risk**

The electronics housing and its built-in components such as display module, main electronics module and I/O electronics module may heat to 80 °C (176 °F) during operation through heat transfer from the process as well as power dissipation within the electronics. During operation the sensor may assume a temperature near the temperature of the measured material.

Danger of burns due to heated surfaces!

- For high process temperatures: Install protection against contact in order to prevent burns.

## **2.3 Workplace safety**

For work on and with the device:

- Wear the required personal protective equipment according to federal/national regulations.

With divisible probe rods, medium may penetrate into the joints between the individual parts of the rod. This medium may escape when loosening the joints. In the case of dangerous (e. g. aggressive or toxic) media this may cause injuries.

- When loosening the joints between the individual parts of the probe rod: Wear appropriate protective equipment according to the medium.

## **2.4 Operational safety**

Risk of injury.

- Operate the device in proper technical condition and fail-safe condition only.
- The operator is responsible for interference-free operation of the device.

### **Conversions to the device**

Unauthorized modifications to the device are not permitted and can lead to unforeseeable dangers.

- If, despite this, modifications are required, consult with the manufacturer.

### **Repair**

To ensure continued operational safety and reliability,

- Carry out repairs on the device only if they are expressly permitted.
- Observe federal/national regulations pertaining to repair of an electrical device.
- Use original spare parts and accessories from the manufacturer only.

### **Hazardous area**

To eliminate a danger for persons or for the facility when the device is used in the hazardous area (e. g. explosion protection, pressure vessel safety):

- Based on the nameplate, check whether the ordered device is permitted for the intended use in the hazardous area.
- Observe the specifications in the separate supplementary documentation that is an integral part of these Instructions.

## **2.5**

### **Product safety**

This measuring device is designed in accordance with good engineering practice to meet state-of-the-art safety requirements, has been tested, and left the factory in a condition in which they are safe to operate.

It meets general safety standards and legal requirements. It also complies with the EC directives listed in the device-specific EC Declaration of Conformity. Pepperl+Fuchs confirms this by affixing the CE mark to the device.

### 3 Product description

#### 3.1 Design

##### 3.1.1 Device

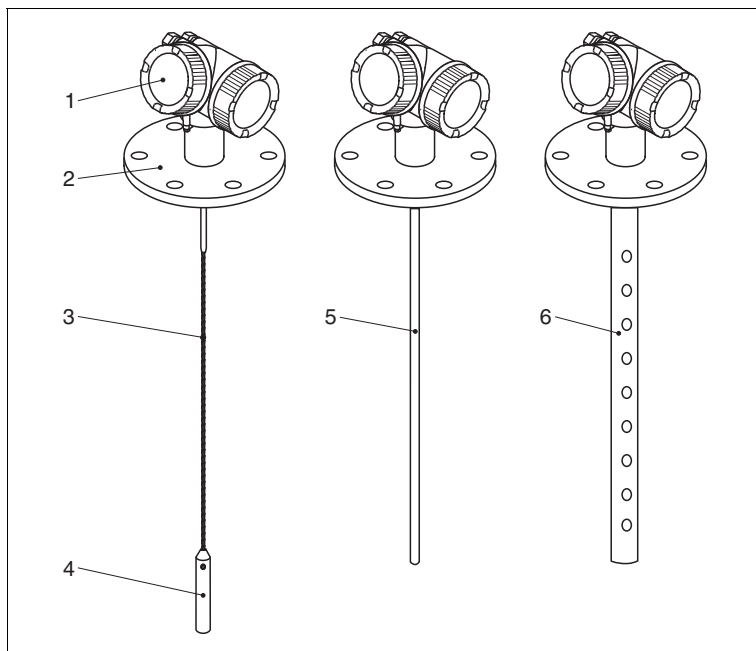

Figure 3.1 Design

- 1 Electronics housing
- 2 Process connection (here as an example: flange)
- 3 Rope probe
- 4 End-of-probe weight
- 5 Rod probe
- 6 Coax probe

### 3.1.2 Electronics housing

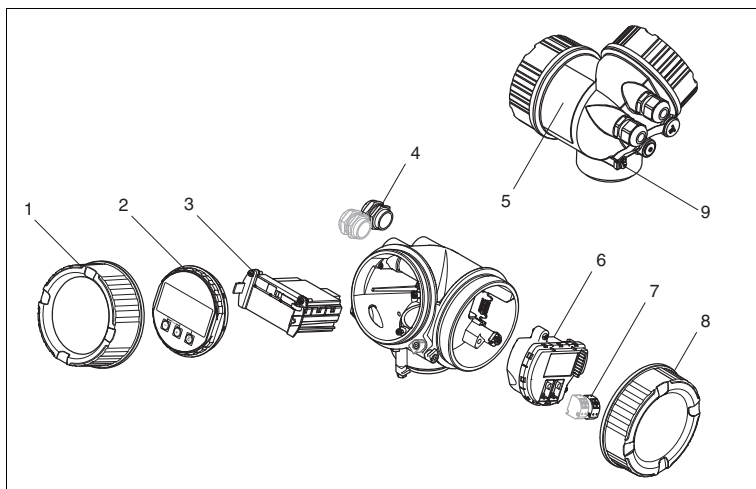

Figure 3.2 Design of the electronics housing

- 1 Electronics compartment cover
- 2 Display module
- 3 Main electronics module
- 4 Cable glands (1 or 2, depending on instrument version)
- 5 Nameplate
- 6 I/O electronics module
- 7 Terminals (pluggable spring terminals)
- 8 Connection compartment cover
- 9 Grounding terminal

## 4 Incoming acceptance and product identification

### 4.1 Incoming acceptance







|   |   |  |
|---|---|--|
|    |    | <p>Is the order code on the delivery note (1) identical to the order code on the product sticker (2)?</p>              |
|   |    |  |
|    |    | <p>Are the goods undamaged?</p>  |
|    |   | <p>Do the nameplate data match the ordering information on the delivery note?</p>                                      |
|  |  | <p>Is the DVD (operating tool) present?<br/>If required (see nameplate): Are the Safety Instructions (SI) present?</p> |

Table 4.1

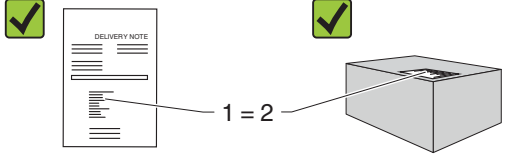
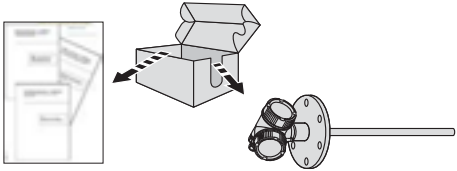

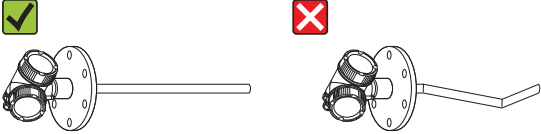
**Note!**

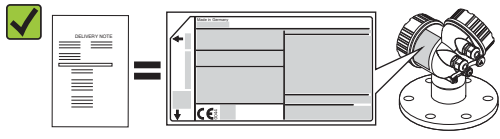
If one of the conditions does not comply, contact your Pepperl+Fuchs distributor.

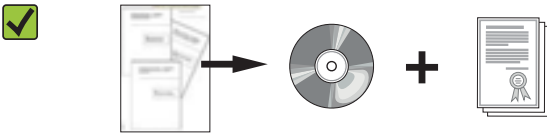
## 4.2 Product identification

The following options are available for identification of the measuring device:

- Nameplate specifications
- Order code with breakdown of the device features on the delivery note
- Scan the 2-D matrix code (QR code) on the nameplate: all the information for the measuring device is displayed.

### Nameplate

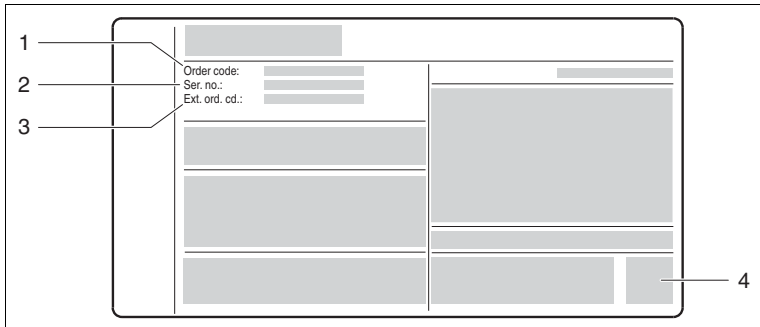

Figure 4.1 Example of a nameplate

- 1 Order code
- 2 Serial number (Ser. no.)
- 3 Extended order code (Ext. ord. cd.)
- 4 2-D matrix code (QR code)



### **Note!**

For detailed information about interpreting the nameplate specifications, refer to the Operating Instructions for the device.

Only 33 digits of the extended order code can be indicated on the nameplate. If the extended order code exceeds 33 digits, the rest will not be shown. However, the complete extended order code can be viewed in the operating menu of the device in the **Extended order code 1 to 3** parameter.

## 4.3 Device documentation



**Note!**

These Instructions are Quick Start Guides; they are not a substitute for the Operating Instructions pertaining to the device.

Detailed information about the device can be found in the Operating Instructions and the other documentation via internet [www.pepperl-fuchs.com](http://www.pepperl-fuchs.com).

The complete device documentation consists of:

- these Quick Start Guide
- the Operating Instructions
- the Technical Information



**Note!**

Technical documentation can also be downloaded from the Pepperl+Fuchs web site: [www.pepperl-fuchs.com](http://www.pepperl-fuchs.com). However this technical documentation applies to a particular instrument family and is not assigned to a specific device.

## 5 Storage, Transport

### 5.1 Storage conditions

- Permitted storage temperature: -40 ... +80 °C (-40 ... +176 °F)
- Use the original packaging.

### 5.2 Transport product to the measuring point



#### **Warning!**

Risk of injury!

Housing or probe may be damaged or break away.

- Transport the measuring device to the measuring point in its original packaging or at the process connection.
- Do not fasten lifting devices (hoisting slings, lifting eyes etc.) at the housing or the probe but at the process connection. Take into account the mass center of the device in order to avoid unintended tilting.
- Comply with the safety instructions, transport conditions for devices over 18 kg (39.6 lbs) (IEC 61010).

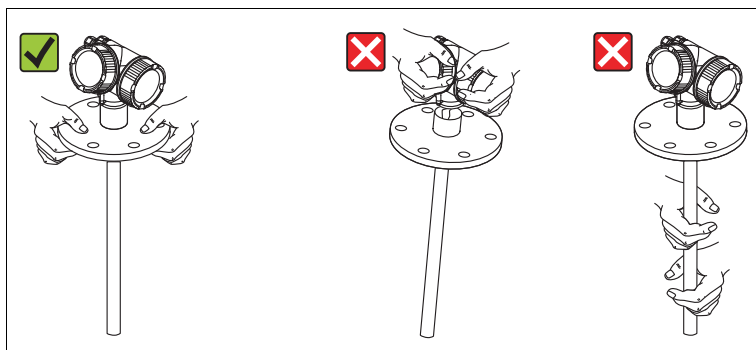

Figure 5.1



## 6 Mounting

### 6.1 Mounting requirements

#### 6.1.1 Suitable mounting position

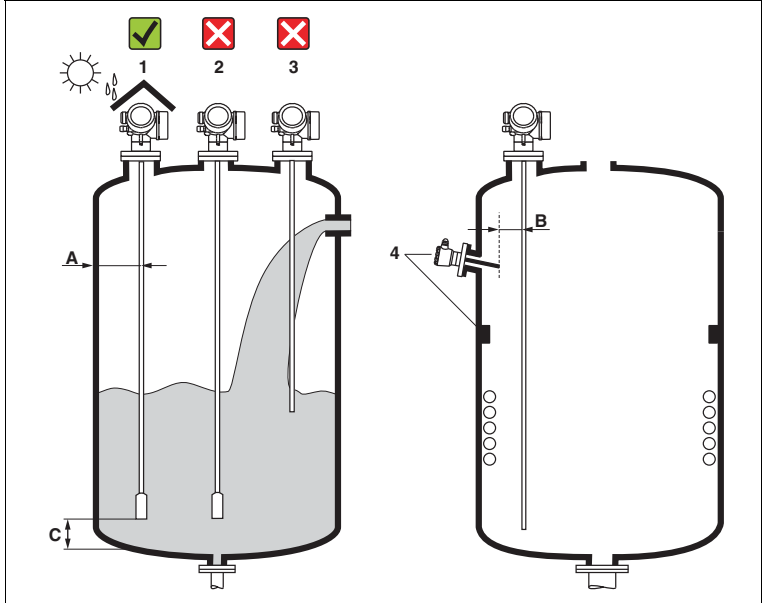

Figure 6.1 Mounting requirements

#### Mounting distances

- Distance (A) between wall and rod or rope probe:
  - for smooth metallic walls: > 50 mm (2 in)
  - for plastic walls: > 300 mm (12 in) to metallic parts outside the vessel
  - for concrete walls: > 500 mm (20 in), otherwise the available measuring range may be reduced.
- Distance (B) between rod or rope probe and internal fittings in the vessel: > 300 mm (12 in)
- Distance (C) from end of probe to bottom of the vessel:
  - Rope probe: > 150 mm (6 in)
  - Rod probe: > 10 mm (0.4 in)
  - Coax probe: > 10 mm (0.4 in)

#### **Note!**

For coax probes the distance to the wall and to internal fittings is arbitrary.



### Additional conditions

- When mounting in the open, a weather protection cover (1) may be installed to protect the device against extreme weather conditions.
- In metallic vessels: Preferably do not mount the probe in the center of the vessel (2), as this would lead to increased interference echoes.  
If a central mounting position can not be avoided, it is crucial to perform an interference echo suppression (mapping) after the commissioning of the device.
- Do not mount the probe in the filling curtain (3).
- Avoid buckling the rope probe during installation or operation (e. g. through product movement against silo wall) by selecting a suitable mounting location.
- Check the probe regularly for defects.



#### **Note!**

With suspended rope probes (probe end not fixed at the bottom) the distance between the probe rope and internal fittings in the tank must not fall below 300 mm (12 in) during the entire process. A sporadic contact between the probe weight and the cone of the vessel, however, does not influence the measurement as long as the dielectric constant of the medium is at least  $DC = 1.8$ .



#### **Note!**

When mounting the electronics housing into a recess (e. g. in a concrete ceiling), observe a minimum distance of 100 mm (4 in) between the cover of the terminal compartment/electronics compartment and the wall. Otherwise the connection compartment/electronics compartment is not accessible after installation.

## 6.1.2 Notes on the process connection

Probes are mounted to the process connection with threaded connections or flanges. If during this installation there is the danger that the probe end moves so much that it touches the tank floor or cone at times, the probe must, if necessary, be shortened and fixed down.

### Threaded connection

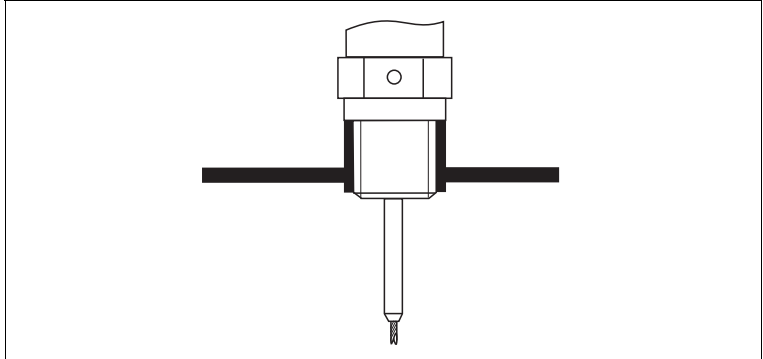

Figure 6.2 Mounting with threaded connection; flush with the container ceiling

### Seal

The thread as well as the type of seal comply to DIN 3852 Part 1, screwed plug form A.

They can be sealed with the following types of sealing rings:

- Thread G3/4: according to DIN 7603 with the dimensions 27 x 32 mm
- Thread G1-1/2: according to DIN 7603 with the dimensions 48 x 55 mm

Please use a sealing ring according to this standard in the form A, C or D and of a material that is resistant to the application.

### Nozzle mounting

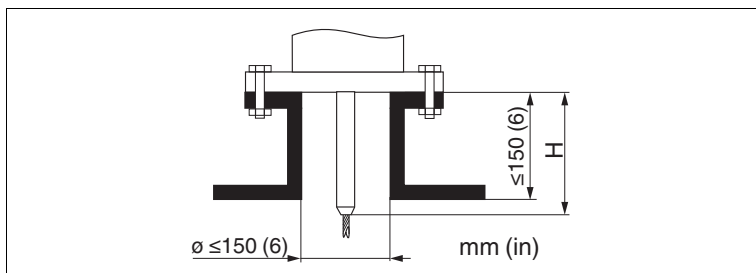

Figure 6.3

- Permissible nozzle diameter:  $\leq 150$  mm (6 in).  
For larger diameters the near range measuring capability may be reduced.  
For nozzles  $\geq$  DN300: see next section.
- Permissible nozzle height <sup>1</sup>:  $\leq 150$  mm (6 in).  
For a larger height the near range measuring capability may be reduced.



#### **Note!**

With thermally insulated vessels the nozzle should also be insulated in order to prevent condensate formation.

<sup>1</sup> Larger nozzle heights on request

### Center rod

For rope probes it may be necessary to use a version with center rod in order to prevent the probe rod from coming into contact with the nozzle wall. Probes with center rod are available for the device.

| Max. nozzle height (= length of the center rod) | Option to be selected in feature "Probe" |
|---|--|
| 150 mm  | 2  |
| 6 in  | 3  |
| 300 mm  | E  |
| 12 in   | F  |

Table 6.1

### Installation in nozzles $\geq$ DN300

If installation in  $\geq$  300mm/12 in nozzles is unavoidable, installation must be carried out in accordance with the following sketch.

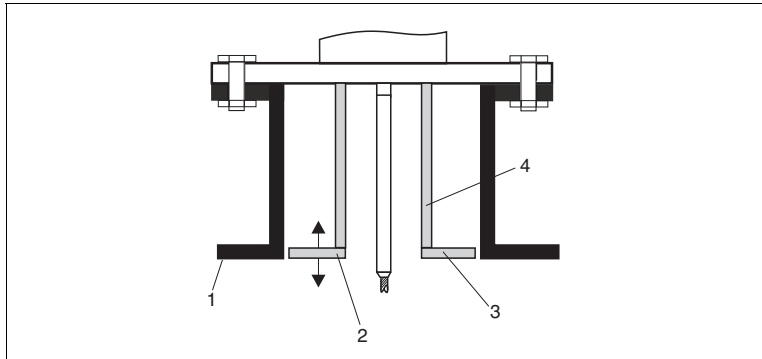

Figure 6.4

- 1 Lower edge of the nozzle
- 2 Approx. flush with the lower edge of the nozzle ( $\pm 50$  mm/2 in)
- 3 Plate
- 4 Pipe diameter 150 to 180 mm (6 to 7 in)

| Nozzle diameter       | Plate diameter        |
|-----------------------|-----------------------|
| 300 mm (12 in)        | 280 mm (11 in)        |
| $\geq$ 400 mm (16 in) | $\geq$ 350 mm (14 in) |

Table 6.2

### 6.1.3

### Mounting cladded flanges

For usage of cladded flanges, observe the following:

- Use flange screws according to the number of flange holes.
- Tighten the screws with the required torque (see table).
- Retighten the screws after 24 hours or after the first temperature cycle.
- Depending on process pressure and process temperature check and retighten the screws at regular intervals.

| Flange size      | Number of screws | Recommended torque [Nm] |         |
|------------------|------------------|-------------------------|---------|
|                  |                  | minimum                 | maximum |
| <b>EN</b>        |                  |                         |         |
| DN40/PN40        | 4                | 35                      | 55      |
| DN50/PN16        | 4                | 45                      | 65      |
| DN50/PN40        | 4                | 45                      | 65      |
| DN80/PN16        | 8                | 40                      | 55      |
| DN80/PN40        | 8                | 40                      | 55      |
| DN100/PN16       | 8                | 40                      | 60      |
| DN100/PN40       | 8                | 55                      | 80      |
| DN150/PN16       | 8                | 75                      | 115     |
| DN150/PN40       | 8                | 95                      | 145     |
| <b>ASME</b>      |                  |                         |         |
| 1-1/2 in/150 lbs | 4                | 20                      | 30      |
| 1-1/2 in/300 lbs | 4                | 30                      | 40      |
| 2 in/150 lbs     | 4                | 40                      | 55      |
| 2 in/300 lbs     | 8                | 20                      | 30      |
| 3 in/150 lbs     | 4                | 65                      | 95      |
| 3 in/300 lbs     | 8                | 40                      | 55      |
| 4 in/150 lbs     | 8                | 45                      | 70      |
| 4 in/300 lbs     | 8                | 55                      | 80      |
| 6 in/150 lbs     | 8                | 85                      | 125     |
| 6 in/300 lbs     | 12               | 60                      | 90      |
| <b>JIS</b>       |                  |                         |         |
| 10K 40A          | 4                | 30                      | 45      |
| 10K 50A          | 4                | 40                      | 60      |
| 10K 80A          | 8                | 25                      | 35      |
| 10K 100A         | 8                | 35                      | 55      |
| 10K 100A         | 8                | 75                      | 115     |

Table 6.3

## 6.1.4 Securing the probe

### Securing rope probes

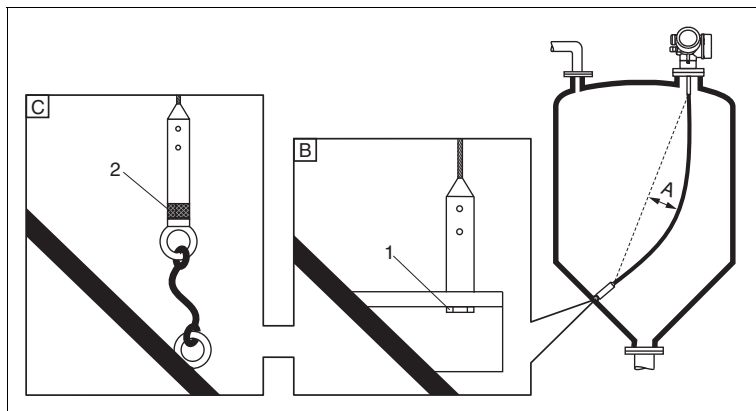

Figure 6.5

- A** Sag of the rope:  $\geq 1$  cm per 1 m of the probe length (0.12 in per 1 ft of the probe length)
- B** Reliably grounded end of probe
- C** Reliably isolated end of probe
- 1** Mounting and contact with a bolt
- 2** Mounting kit isolated

- The end of the probe needs to be secured under the following conditions: if otherwise the probe sporadically comes into contact with the wall of the vessel, the outlet cone, internal fittings or other parts of the installation.
- The end of probe can be secured at its internal thread: rope 4 mm (1/6 in), 316: M14
- The fixing must be either reliably grounded or reliably insulated. If it is not possible to mount the probe weight with a reliably insulated connection, it can be secured using an isolated eyelet, which is available as an accessory.
- In order to prevent an extremely high tensile load (e. g. due to thermal expansion) and the risk of rope crack, the rope has to be slack. Make the rope longer than the required measuring range such that there is a sag in the middle of the rope that is  $\geq 1$  cm/(1 m rope length) [0.12 in/(1 ft rope length)].

### Securing rod probes

- For Ex-approvals: For probe lengths  $\geq 3$  m (10 ft) a support is required.
- In general, rod probes must be supported if there is a horizontal flow (e. g. from an agitator) or in the case of strong vibrations.
- Rod probes may only be supported at the end of the probe.

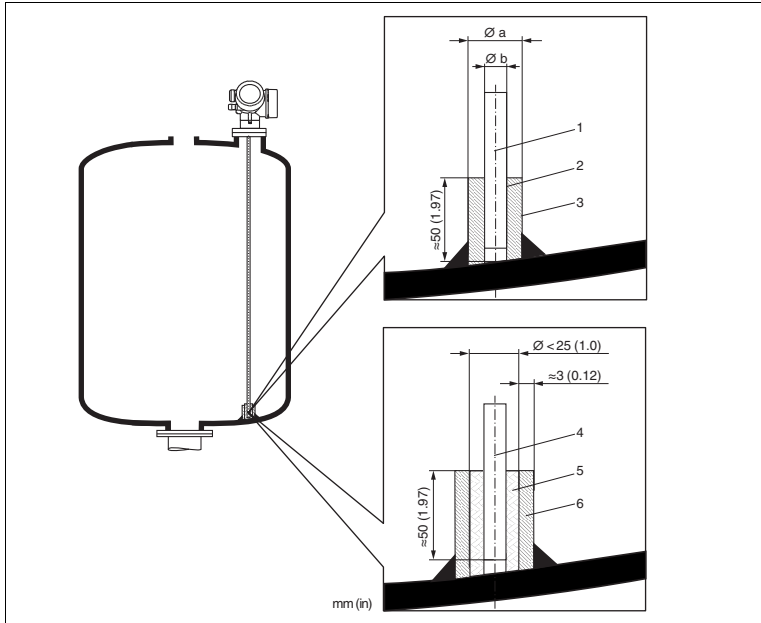

Figure 6.6

- 1 Probe rod, uncoated
- 2 Sleeve bored tight to ensure electrical contact between the rod and sleeve!
- 3 Short metal pipe, e. g. welded in place
- 4 Probe rod, coated
- 5 Plastic sleeve, e. g. PTFE, PEEK or PPS
- 6 Short metal pipe, e. g. welded in place

| Ø probe         | Øa [mm (in)] | Øb [mm (in)] |
|-----------------|--------------|--------------|
| 8 mm (1/3 in)   | < 14 (0.55)  | 8.5 (0.34)   |
| 12 mm (1/2 in)  | < 20 (0.78)  | 12.5 (0.52)  |
| 16 mm (0.63 in) | < 26 (1.02)  | 16.5 (0.65)  |

Table 6.4





**Warning!**

Poor grounding of the end of probe may cause measuring errors.

- Apply a narrow sleeve which has good electrical contact to the probe.



**Warning!**

Welding may damage the main electronics module.

- Before welding: Ground the probe and dismount electronics.

**Securing coax probes**

For WHG-approvals: For probe lengths  $\geq 3$  m (10 ft) a support is required.

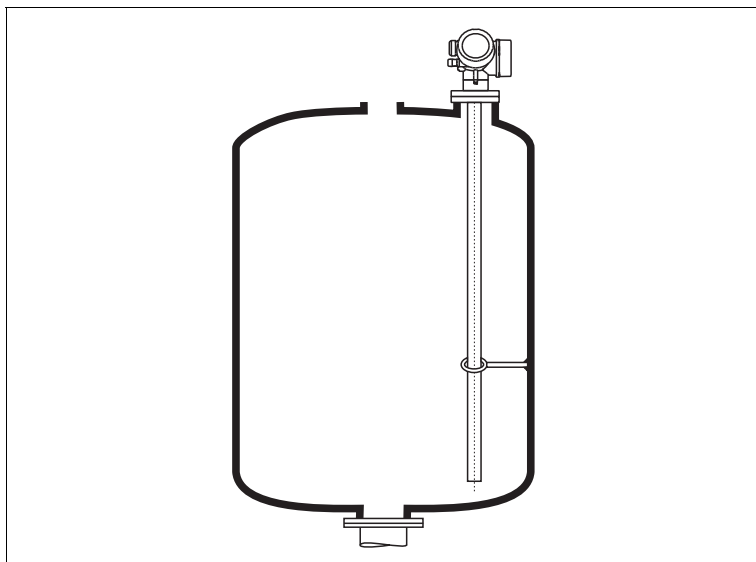

Figure 6.7

Coax probes can be supported at any point of the outer tube.

### 6.1.5 Special mounting conditions

#### Bypasses and stilling wells

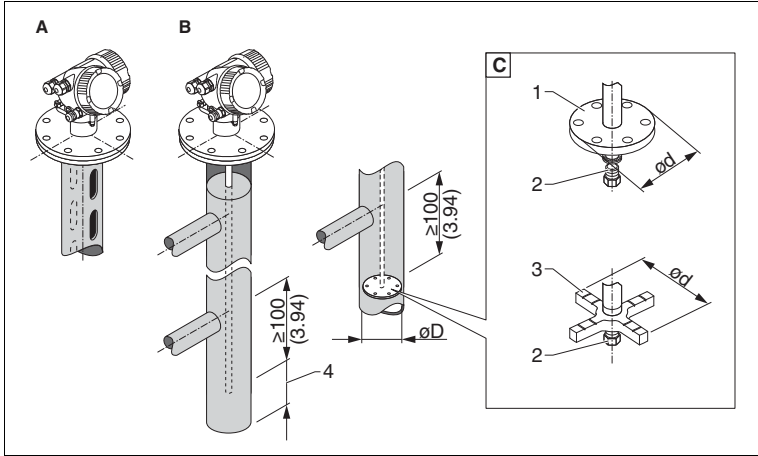

Figure 6.8

- A** Mounting in a stilling well
- B** Mounting in a bypass
- C** Center washer or centering star (on request)
  - 1 Metallic center washer (316L) for level measurement (on request)
  - 2 Fixing screw; torque: 25 Nm ±5 Nm
  - 3 Non-metallic centering star (PEEK, PFA) for interface measurement (on request)
  - 4 Minimum distance between end of probe and lower edge of the bypass; see table below

Allocation of probe type and center washer or centering star to pipe diameter

| Type of probe | Center washer or centering star |          | Pipe                    |
|---------------|---------------------------------|----------|-------------------------|
|               | Ød [mm (in)]                    | Material | ØD [mm (in)]            |
| Rod probe     | 75 (2.95)                       | 316L     | DN80/3 to DN100/4 in    |
| Rod probe     | 45 (1.77)                       | 316L     | DN50/2 to DN65/2-1/2 in |
| Rope probe    | 75 (2.95)                       | 316L     | DN80/3 to DN100/4 in    |

Table 6.5

Minimum distance between end of probe and lower edge of the bypass

| Type of probe | Minimum distance |
|---------------|------------------|
| Rope          | 150 mm (6 in)    |
| Rod           | 10 mm (0.4 in)   |
| Coax          | 10 mm (0.4 in)   |

Table 6.6

- Pipe diameter: > 40 mm (1.6 in) for rod probes
- Rod probe installation can take place up to a diameter size of 150 mm (6 in). In the event of larger diameters, a coax probe is recommended.
- Side disposals, holes or slits and welded joints that protrude up to approx. 5 mm (0.2 in) inwards do not influence the measurement.
- The pipe may not exhibit any steps in diameter.
- The probe must be 100 mm (4 in) longer than the lower disposal.
- Within the measuring range, the probe must not get into contact with the pipe wall. If necessary, use a center washer or centering star.
- If the center washer or centering star is mounted at the end of the probe, it enables a reliable recognition of the end-of-probe signal.
- Coax probes can always be applied if there is enough mounting space.



**Note!**

For bypasses with condensate formation (water) and a medium with low dielectric constant (e. g. hydrocarbons):

In the course of time the bypass is filled with condensate up to the lower disposal and for low levels the level echo is superimposed by the condensate echo. Thus in this range the condensate level is measured instead of the correct level. Only higher levels are measured correctly. To prevent this, position the lower disposal 100 mm (4 in) below the lowest level to be measured and apply a metallic centering disk at the height of the lower edge of the lower disposal.



**Note!**

With heat insulated tanks the bypass should also be insulated in order to prevent condensate formation.



**Note!**

For rope probes with a length exceeding 2 m (6.7 ft) an additional weight or a spring should be mounted in addition to the center washer in order to tighten the rope.



**Note!**

For information on bypass solutions from Pepperl+Fuchs please contact your Pepperl+Fuchs sales representative.

### Non-metallic vessels

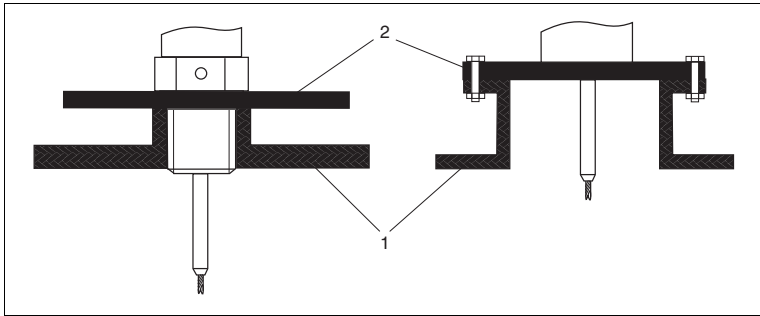

Figure 6.9

- 1 Non-metallic vessel
- 2 Metal sheet or metal flange

To measure, device with a rod probe needs a metallic surface at the process connection. Therefore:

- Select an instrument version with metal flange (minimum size DN50/2 in).
- Or: mount a metal sheet with a diameter of at least 200 mm (8 in) to the probe at the process connection. Its orientation must be perpendicular to the probe.



**Note!**

No additional measures are required for coax probes.

### Plastic or glass tanks: Mounting the probe externally at the wall

For plastic and glass tanks, the probe can also be mounted on the outside wall under specific conditions.

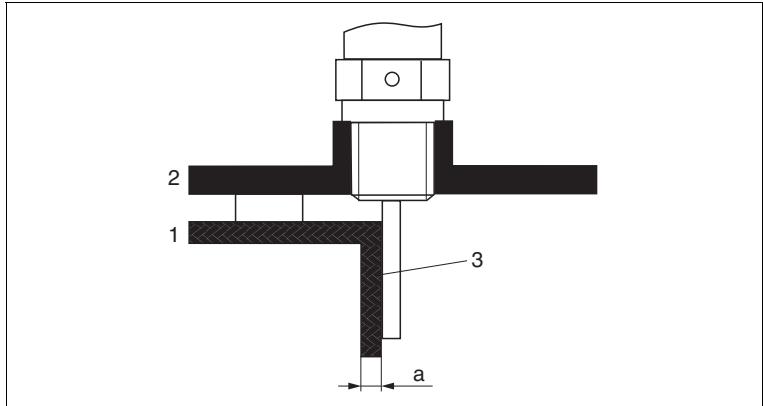

Figure 6.10

- 1 Plastic or glass tank
- 2 Metal sheet with threaded sleeve
- 3 No free space between tank wall and probe!

#### Requirements

- The dielectric constant of the medium must be at least  $DC > 7$ .
- The tank wall must be non-conductive.
- Maximum wall thickness (a):
  - Plastic: < 15 mm (0.6 in)
  - Glass: < 10 mm (0.4 in)
- There may be no metallic reinforcements fixed to the tank.

#### Mounting conditions:

- The probe must be mounted directly to the tank wall (no open space)
- A plastic half pipe with a diameter of approx. 200 mm (8 in), or some other protective unit, must be affixed externally to the probe to prevent any influences on the measurement.
- If the tank diameter is less than 300 mm (12 in):  
A metallic grounding sheet must be installed at the opposite side of the tank. The sheet must be conductively connected to the process connection and cover about the half of the vessel's circumference.
- If the tank diameter exceeds 300 mm (12 in):  
A metal sheet with a diameter of at least 200 mm (8 in) must be mounted to the probe at the process connection. Its orientation must be perpendicular to the probe (see above).

### Calibration for external probe mounting

If the probe is mounted externally at the wall of the tank, the speed of signal propagation will be reduced. There are two possibilities to compensate for this effect.

#### Compensation with the gas phase compensation factor

The effect of the dielectric wall can be compared to the effect of a dielectric gas phase. Thus it can be compensated for in the same manner. The compensation factor is given by the quotient of the actual probe length LN and the probe length measured when the tank is empty.



#### **Note!**

The device looks for the end of probe signal in the subtracted curve. Thus, the value of the measured probe length depends on the mapping. In order to obtain an exact value, it is advisable to determine the probe length manually using the envelope curve display in PACTware.

| Step | Parameter  | Action   |
|------|--|--|
| 1    | Expert → Sensor → Gas phase compensation → GPC mode          | Select the <b>Const. GPC factor</b> option.                        |
| 2    | Expert → Sensor → Gas phase compensation → Const. GPC factor | Enter quotient: "(Actual probe length) / (Measured probe length)". |

Table 6.7

#### Compensation via the calibration parameters

If an actual gas phase has to be compensated for, the gas phase compensation functionality is no longer available for a correction of the external mounting. In this case the calibration parameters (**Empty calibration** and **Full calibration**) must be adjusted and a value longer than the actual probe length has to be entered into the **Present probe length** parameter. The correction factor for these three parameters is given by the quotient of the probe length measured when the tank is empty and the actual probe length LN.



#### **Note!**

The device looks for the end of probe signal in the subtracted curve. Thus, the value of the measured probe length depends on the mapping. In order to obtain an exact value, it is advisable to determine the probe length manually using the envelope curve display in PACTware.

| Step | Parameter   | Action  |
|------|---|---|
| 1    | Setup → Empty calibration   | Increase parameter value by "(Measured probe length) / (Present probe length)". |
| 2    | Setup → Full calibration  | Increase parameter value by "(Measured probe length) / (Present probe length)". |
| 3    | Setup → Advanced setup →<br>Probe settings →<br>Probe length correction →<br>Confirm probe length | Select the <b>Manual input</b> option.  |
| 4    | Setup → Advanced setup →<br>Probe settings →<br>Probe length correction →<br>Present probe length | Enter measured probe length.  |

Table 6.8

## 6.2 Mounting the device

### 6.2.1 Required mounting tools

- For mounting thread 3/4 in: Hexagonal wrench 36 mm
- For mounting thread 1-1/2 in: Hexagonal wrench 55 mm
- To shorten rod or coax probes: Saw
- To shorten rope probes:
  - Allen key AF 3 mm (for 4 mm ropes) or AF 4 mm (for 6 mm ropes)
  - Saw or bolt cutter
- For flanges and other process connections: appropriate mounting tools
- To turn the housing: Hexagonal wrench 8 mm

### 6.2.2 Shortening the probe



#### **Note!**

When shortening the probe: Enter the new length of probe into the Quick Start Guide which can be found in the electronics housing behind the display module.

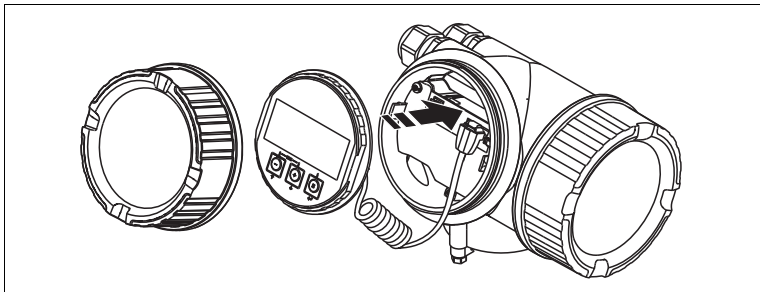

Figure 6.11

#### **Shortening rod probes**

Rod probes must be shortened if the distance to the container floor or outlet cone is less than 10 mm (0.4 in). The rods of a rod probe are shortened by sawing at the bottom end.



### Shortening rope probes

Rope probes must be shortened if the distance to the container floor or outlet cone is less than 150 mm (6 in).

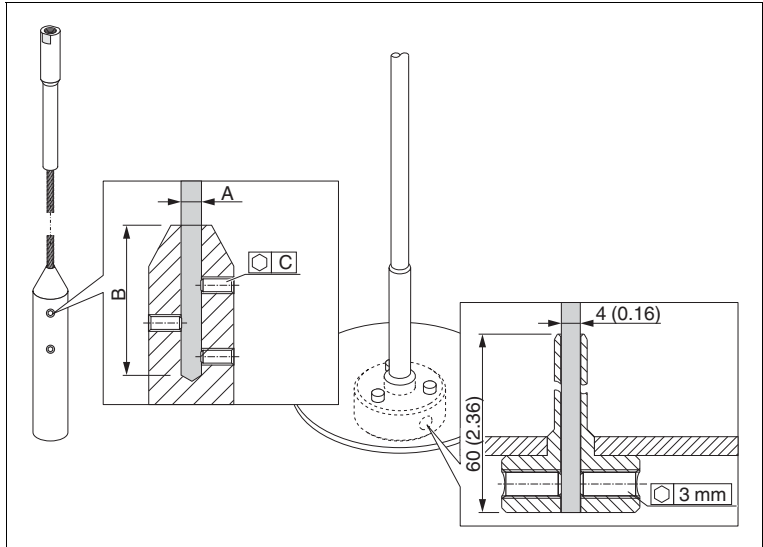

Figure 6.12

| Rope material | A              | B              | C    | Torque for set screws |
|---------------|----------------|----------------|------|-----------------------|
| 316           | 4 mm (0.16 in) | 40 mm (1.6 in) | 3 mm | 5 Nm (3.69 lbf ft)    |

Table 6.9



### Shortening rope probes

- Using an Allen key, loosen the set screws at the end-of-probe weight.  
**Note:** The set screws have got a clamping coating in order to prevent accidental loosening. Thus an increased torque might be necessary to loosen them.
- Remove released rope from the weight.
- Measure off new rope length.
- Wrap adhesive tape around the rope at the point to be shortened to prevent it from fanning out.
- Saw off the rope at a right angle or cut it off with a bolt cutter.
- Insert the rope completely into the weight.
- Screw the set screws into place. Due to the clamping coating of the setscrews application of a screw locking fluid is not necessary.

### Shortening coax probes

Coax probes must be shortened if the distance to the container floor or outlet cone is less than 10 mm (0,4 in).



#### **Note!**

Coax probes can be shortened max. 80 mm (3.2 in) from the end. They have centering units inside, which fix the rod centrally in the pipe. The centerings are held with borders on the rod. Shortening is possible up to approx. 10 mm (0.4 in) below the centering unit.

The coax probe is shortened by sawing the pipe at the bottom end.

## 6.2.3 Mounting the device

### Mounting devices with thread

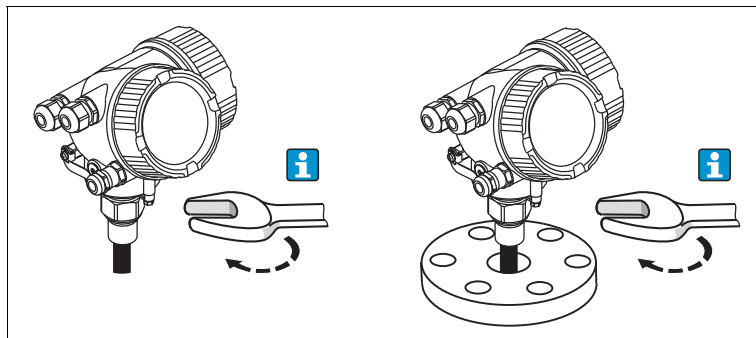

Figure 6.13

Devices with mounting thread are screwed into a welding boss or a flange and are usually also secured with these.



#### **Note!**

- Tighten with the hexagonal nut only:
  - Thread 3/4 in: Hexagonal wrench 36 mm
  - Thread 1-1/2 in: Hexagonal wrench 55 mm
- Maximum permissible torque:
  - Thread 3/4 in: 45 Nm
  - Thread 1-1/2 in: 450 Nm
- Recommended torque when using the supplied aramid fibre seal and a process pressure of 40 bar (580 psi):
  - Thread 3/4 in: 25 Nm
  - Thread 1-1/2 in: 140 Nm
- When installing in metal containers, take care to ensure good metallic contact between the process connection and container.

#### **Flange mounting**

If a seal is used, be sure to use unpainted metal bolts to ensure good electrical contact between probe flange and process flange.

### Mounting rope probes



#### **Warning!**

Electrostatic discharges may damage the electronics.

- Earth the housing before lowering the rope into the vessel.

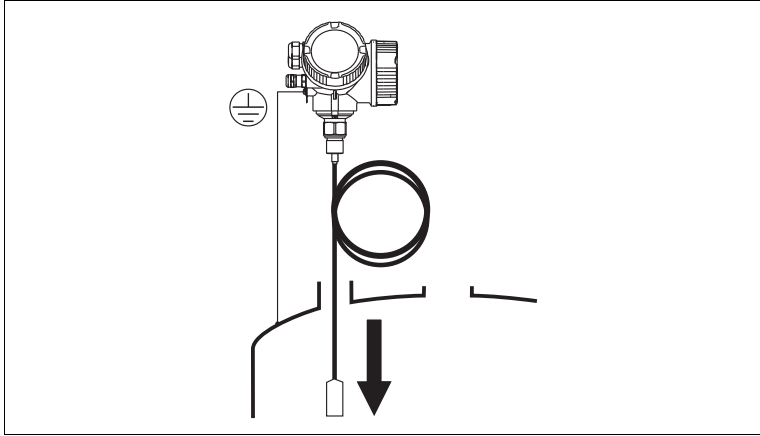

Figure 6.14

When lowering the rope probe into the vessel, observe the following:

- Uncoil rope and lower it slowly and carefully into the vessel.
- Do not kink the rope.
- Avoid any backlash, since this might damage the probe or the vessel fittings.

## 6.2.4 Mounting the "Sensor remote" version



### **Note!**

This section is only valid for devices of the version "Probe design" = "Sensor remote" (feature "Probe design", option B).

For the version "Probe design = Sensor remote" the following is supplied:

- The probe with the process connection
- The electronics housing
- The mounting bracket for wall or pipe mounting of the electronics housing
- The connection cable (length as ordered). The cable has got one straight and one angled plug (90°). Depending on the local conditions the angled plug can be connected at the probe or at the electronics housing.



### **Warning!**

The plugs of the connection cable may be damaged by mechanical stress.

- Mount the probe and the electronics housing tightly before connecting the cable.
- Lay the cable such that it is not exposed to mechanical stress. Minimum bending radius: 100 mm (4 in).
- When connecting the cable: Connect the straight plug before the angled one. Torque for both coupling nuts: 6 Nm.



### **Note!**

If the measuring point is exposed to strong vibrations, an additional locking compound (e. g. Loctite 243) can be applied at the plug connectors.

### Mounting the electronics housing

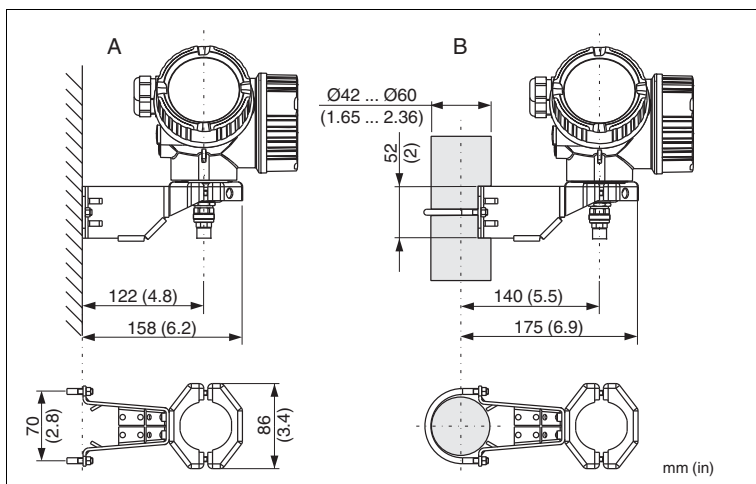

Figure 6.15 Mounting the electronics housing using the mounting bracket

- A Wall mounting
- B Pipe mounting

### Connecting the cable

Required tools: open-end wrench AF 18

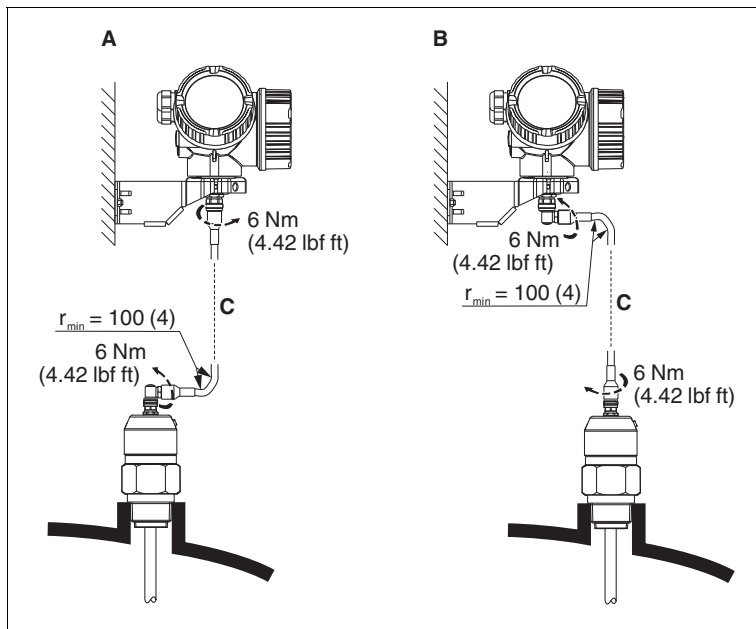

Figure 6.16

- A Angled plug at the probe
- B Angled plug at the electronics housing
- C Length of the remote cable as ordered

## 6.2.5 Turning the transmitter housing

To provide easier access to the connection compartment or display module, the transmitter housing can be turned:

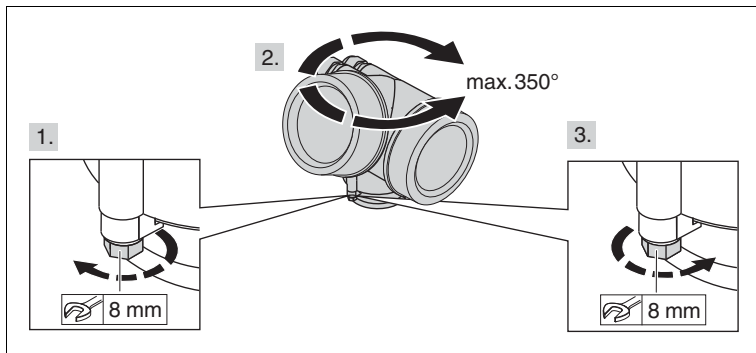

Figure 6.17

### Turning the transmitter housing

1. Unscrew the securing screw using an open-ended wrench.
2. Rotate the housing in the desired direction.
3. Tighten the securing screw (1.5 Nm for plastics housing; 2.5 Nm for aluminium or stainless steel housing).



## 6.2.6 Turning the display module

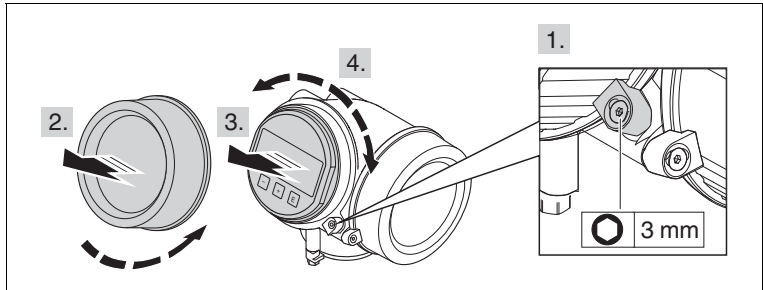

Figure 6.18

### Turning the display module

1. If present: Loosen the screw of the securing clamp of the electronics compartment cover using an Allen key and turn the clamp 90° counterclockwise.
2. Unscrew cover of the electronics compartment from the transmitter housing.
3. Pull out the display module with a gentle rotation movement.
4. Rotate the display module into the desired position: Max. 8 x 45° in each direction.
5. Feed the spiral cable into the gap between the housing and main electronics module and plug the display module into the electronics compartment until it engages.
6. Screw the cover of the electronics compartment firmly back onto the transmitter housing.
7. Tighten the securing clamp again using the Allen key (torque: 2.5 Nm).

## 6.3

### Post-installation check

- Is the device undamaged (visual inspection)?
- Does the device conform to the measuring point specifications?  
For example:
  - Process temperature
  - Process pressure
  - Ambient temperature range
  - Measuring range
- Are the measuring point identification and labeling correct (visual inspection)?
- Is the device adequately protected from precipitation and direct sunlight?
- Are the securing screw and securing clamp tightened securely?

## 7 Electrical connection

### 7.1 Connection conditions

#### 7.1.1 Terminal assignment

##### PROFIBUS PA

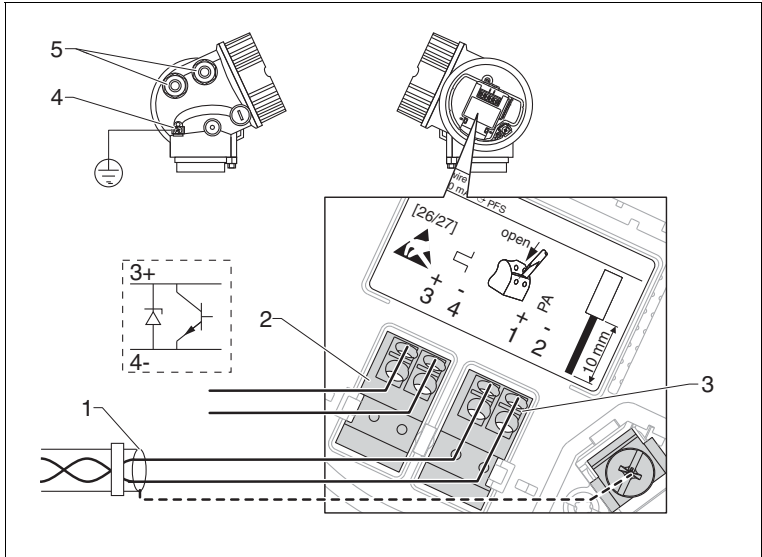

Figure 7.1 Terminal assignment PROFIBUS PA

- 1 Cable screen: observe cable specifications
- 2 Switch output (open collector): terminals 3 and 4
- 3 Connection PROFIBUS PA: terminals 1 and 2
- 4 Terminal for potential equalization line
- 5 Cable entries

Connection examples for the switch output

|   |   |
|---|---|
|  <p>Connection of a relay<br/>Suitable relays (examples):</p> <ul style="list-style-type: none"> <li>• Solid-state relay: Phoenix Contact OV-24DC/480AC/5 with mounting rail connector UMK-1 OM-R/AMS</li> <li>• Electromechanical relay: Phoenix Contact PLC-RSC-12DC/21</li> </ul> |  <p>Connection of a digital input<br/>1 Pull-up resistor<br/>2 Digital input</p> |
|---|---|

Table 7.1



**Note!**

For optimum interference immunity we recommend to connect an external resistor (internal resistance of the relay or Pull-up resistor) of  $< 1\ 000\ \Omega$ .

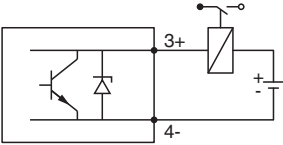
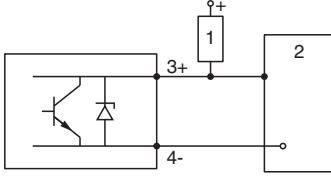
## 7.1.2

### Cable specification

- Minimum cross-section: See the terminal specification in the Technical Information for the device.
- For ambient temperature  $T_{amb} \geq 60 \text{ °C}$  (140 °F): use cable for temperature  $T_{amb} + 20 \text{ K}$ .

### PROFIBUS PA

- Use a twisted, screened two-wire cable, preferably cable type A.



#### **Note!**

For further information on the cable specifications, see PNO Guideline 2.092 "PROFIBUS PA User and Installation Guideline" and IEC 61158-2 (MBP).

### 7.1.3 Device plug connectors



**Note!**

For the versions with fieldbus plug connector (M12 or 7/8 in), the signal line can be connected without opening the housing.

Pin assignment of the M12 plug connector

|  |     |               |
|--|-----|---------------|
|  | Pin | Meaning       |
|  | 1   | Signal +      |
|  | 2   | not connected |
|  | 3   | Signal -      |
|  | 4   | Ground        |

Table 7.2

Pin assignment of the 7/8 in plug connector

|  |     |               |
|--|-----|---------------|
|  | Pin | Meaning       |
|  | 1   | Signal -      |
|  | 2   | Signal +      |
|  | 3   | not connected |
|  | 4   | Screen        |

Table 7.3

## 7.1.4 Power supply

### PROFIBUS PA

| Electrical Output <sup>a</sup>         | Approval <sup>b</sup>  | Terminal voltage        |
|--|--|-------------------------|
| PA: 2-wire; PROFIBUS PA, switch output | <ul style="list-style-type: none"> <li>• Non-Ex</li> <li>• Ex nA</li> <li>• Ex nA(ia)</li> <li>• Ex ic</li> <li>• Ex ic(ia)</li> <li>• Ex d(ia)/XP</li> <li>• Ex ta/DIP</li> <li>• CSA GP</li> </ul> | 9 ... 32 V <sup>c</sup> |
|  | <ul style="list-style-type: none"> <li>• Ex ia/IS</li> <li>• Ex ia + Ex d(ia)/IS + XP</li> </ul>   | 9 ... 30 V <sup>d</sup> |

Table 7.4

- <sup>a</sup> Feature "Electrical Output" the product structure  
<sup>b</sup> Feature "Approval" of the product structure  
<sup>c</sup> Input voltages up to 35 V will not spoil the device.  
<sup>d</sup> Input voltages up to 35 V will not spoil the device.

|   |     |
|---|-----|
| Polarity sensitive                              | no  |
| FISCO/FNICO compliant according to IEC 60079-27 | yes |

Table 7.5

## 7.1.5 Overvoltage protection

If the measuring device is used for level measurement in flammable liquids which requires the use of overvoltage protection according to DIN EN 60079-14, standard for test procedures 60060-1 (10 kA, pulse 8/20  $\mu$ s), overvoltage protection has to be ensured by an external overvoltage protection module.

### External overvoltage protection

For detailed information please refer to [www.pepperl-fuchs.com](http://www.pepperl-fuchs.com)

## 7.2 Connecting the device



### **Warning!**

Explosion hazard!

- Comply with the relevant national standards.
- Observe the specifications in the Safety Instructions (SI).
- Only use the specified cable glands.
- Check whether the supply voltage matches the specifications on the nameplate.
- Before connecting the device: Switch the supply voltage off.
- Before switching on the supply voltage: Connect the potential bonding line to the exterior ground terminal.

Required tools and accessories:

- For instruments with safety pin for the lid: AF3 Allen key
- Wire stripping pliers
- When using stranded wires: wire end sleeves.

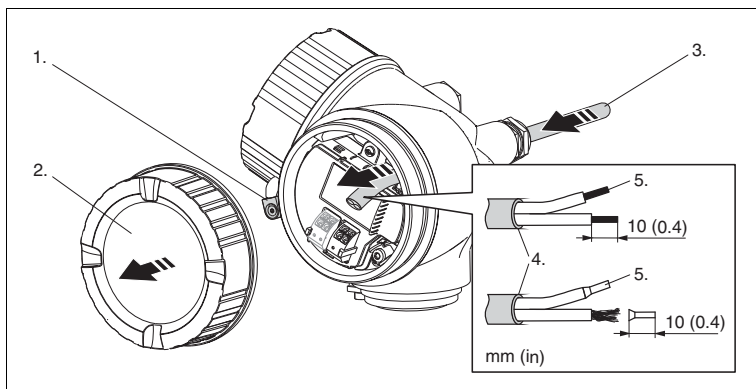

Figure 7.2





### Connecting the device

1. Loosen the screw of the securing clamp of the connection compartment cover and turn the clamp 90° counterclockwise.
2. Unscrew the connection compartment cover.
3. Push the cable through the cable entry. To ensure tight sealing, do not remove the sealing ring from the cable entry.
4. Strip the cable.
5. Strip the cable ends 10 mm (0.4 in). For stranded cables, also attach wire end ferrules.
6. Firmly tighten the cable glands.
7. Connect the cable in accordance with the terminal assignment. See chapter 7.1.1.

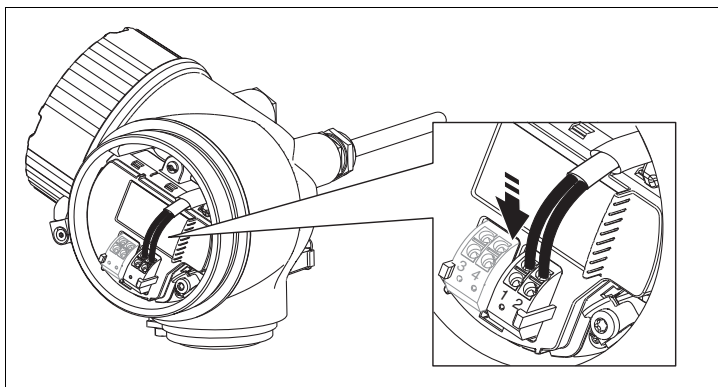

Figure 7.3

8. When using screened cable: Connect the cable screen to the ground terminal.
9. Screw the cover onto the connection compartment.
10. For instruments with safety pin for the lid: Adjust the safety pin so that its edge is over the edge of the display lid. Tighten the safety pin.

## 7.2.1 Pluggable spring-force terminals

Instruments have pluggable spring-force terminals. Rigid conductors or flexible conductors with cable sleeve can directly be inserted and are contacted automatically.

To remove cables from the terminal: Press on the groove between the terminals using a flat-tip screwdriver  $\leq 3$  mm (0.12 in) while pulling the cables out of the terminals.

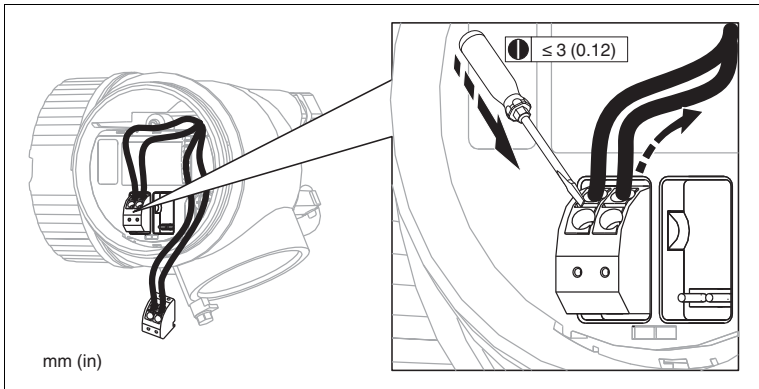

Figure 7.4

## 7.3

### Post-connection check

- Are cables or the device undamaged (visual inspection)?
- Do the cables comply with the requirements?
- Do the cables have adequate strain relief?
- Are all cable glands installed, firmly tightened and correctly sealed?
- Does the supply voltage match the specifications on the transmitter nameplate?
- Is the terminal assignment correct? See chapter 7.1.1.
- If required: Is the protective earth connected correctly? See chapter 7.1.1.
- If supply voltage is present: Is the device ready for operation and do values appear on the display module?
- Are all housing covers installed and firmly tightened?
- Is the securing clamp tightened correctly?

## 8 Integration into a PROFIBUS network

### 8.1 Overview of the device database files (GSD)

|                  |   |
|------------------|---|
| Manufacturer ID  | 93 (5D HEX)   |
| Ident number     | 0E3B HEX  |
| Profil version   | 3.02  |
| GSD file         | Information and files under:<br><ul style="list-style-type: none"> <li>• www.pepperl-fuchs.com</li> <li>• www.profibus.org</li> </ul> |
| GSD file version |   |

Table 8.1

### 8.2 Set device address

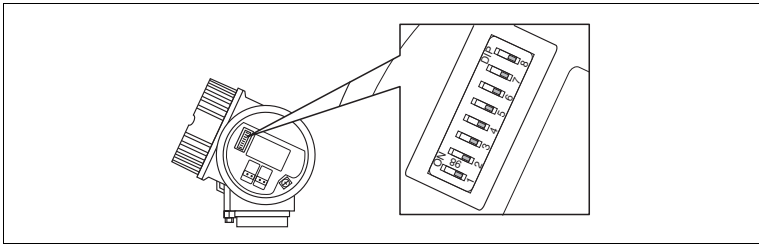

Figure 8.1 Address switches in terminal compartment

#### 8.2.1 Hardware addressing

Setting hardware addressing

1. Set switch 8 to **OFF**.
2. Define the address with switches 1 to 7 according to the table below.

↳ The address change becomes effective after 10 seconds. The device restarts automatically.

| Switch                       | 1 | 2 | 3 | 4 | 5  | 6  | 7  |
|------------------------------|---|---|---|---|----|----|----|
| Value in position <b>ON</b>  | 1 | 2 | 4 | 8 | 16 | 32 | 64 |
| Value in position <b>OFF</b> | 0 | 0 | 0 | 0 | 0  | 0  | 0  |

Table 8.2

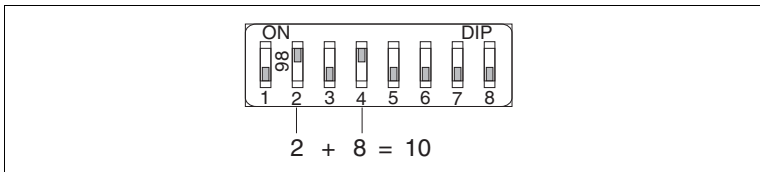

Figure 8.2 Example of hardware addressing: switch 8 is in position **OFF**; switches 1 to 7 define the address.

## 8.2.2 Software addressing



### Setting software addressing

1. Set switch 8 to **ON**.
2. The device restarts automatically. The address remains the same as before (factory setting: 126).
3. Set the required address via the operating menu: Setup → Device address

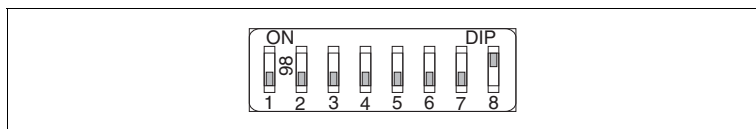

Figure 8.3 Example of software addressing; switch 8 is in position **ON**; the address is defined in the operating menu (Menu Setup → Device address)

## 9 Commissioning (via operating menu)

### 9.1 Display and operating module

#### 9.1.1 Display appearance

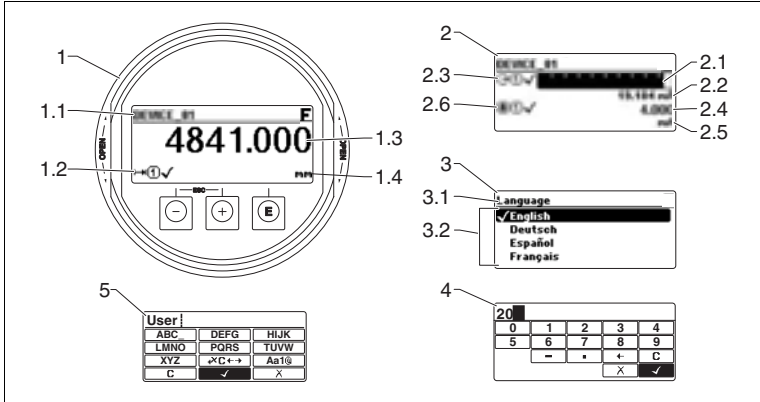

Figure 9.1 Appearance of the display and operation module for on-site operation

- 1 Measured value display (1 value max. size)
- 1.1 Header containing tag and error symbol (if an error is active)
- 1.2 Measured value symbols
- 1.3 Measured value
- 1.4 Unit
- 2 Measured value display (1 bargraph and 1 value)
- 2.1 Bargraph for measured value 1
- 2.2 Measured value 1 (including unit)
- 2.3 Measured value symbols for measured value 1
- 2.4 Measured value 2
- 2.5 Unit for measured value 2
- 2.6 Measured value symbols for measured value 2
- 3 Representation of a parameter (here: a parameter with selection list)
- 3.1 Header containing parameter name and error symbol (if an error is active)
- 3.2 Selection list;  marks the current parameter value.
- 4 Input matrix for numbers
- 5 Input matrix for alphanumeric and special characters

## 9.1.2 Operating elements







| Key   | Meaning   |
|---|---|
|    | <p><b>Minus key</b></p> <p>For menu, submenu<br/>Moves the selection bar upwards in a picklist.<br/>For text and numeric editor<br/>In the input mask, moves the selection bar to the left (backwards).</p>   |
|    | <p><b>Plus key</b></p> <p>For menu, submenu<br/>Moves the selection bar downwards in a picklist.<br/>For text and numeric editor<br/>In the input mask, moves the selection bar to the right (forwards).</p>  |
|    | <p><b>Enter key</b></p> <p>For measured value display</p> <ul style="list-style-type: none"> <li>Pressing the key briefly opens the operating menu.</li> <li>Pressing the key for 2 s opens the context menu.</li> </ul> <p>For menu, submenu</p> <ul style="list-style-type: none"> <li>Pressing the key briefly<br/>Opens the selected menu, submenu or parameter.</li> <li>Pressing the key for 2 s for parameter<br/>If present, opens the help text for the function of the parameter.</li> </ul> <p>For text and numeric editor.</p> <ul style="list-style-type: none"> <li>Pressing the key briefly<br/>– Opens the selected group.<br/>– Carries out the selected action.</li> <li>Pressing the key for 2 s confirms the edited parameter value.</li> </ul> |
|    | <p><b>Escape key combination (press keys simultaneously)</b></p> <p>For menu, submenu</p> <ul style="list-style-type: none"> <li>Pressing the key briefly<br/>– Exits the current menu level and takes you to the next higher level.<br/>– If help text is open, closes the help text of the parameter.</li> <li>Pressing the key for 2 s returns you to the measured value display ("home position").</li> </ul> <p>For text and numeric editor<br/>Closes the text or numeric editor without applying changes.</p>  |
|  | <p><b>Minus/Enter key combination (press and hold down the keys simultaneously)</b></p> <p>Reduces the contrast (brighter setting).</p>   |
|  | <p><b>Plus/Enter key combination (press and hold down the keys simultaneously)</b></p> <p>Increases the contrast (darker setting).</p>  |
|  | <p><b>Minus/Plus/Enter key combination (press and hold down the keys simultaneously)</b></p> <p>For measured value display<br/>Enables or disables the keypad lock.</p>   |

Table 9.1

### 9.1.3 Opening the context menu

Using the context menu, the user can call up the following menus quickly and directly from the operational display:

- Setup
- Conf. backup disp.
- Simulation

Calling up and closing the context menu

The user is in the operational display.

1. Press **[E]** for 2 s.

↳ The context menu opens.

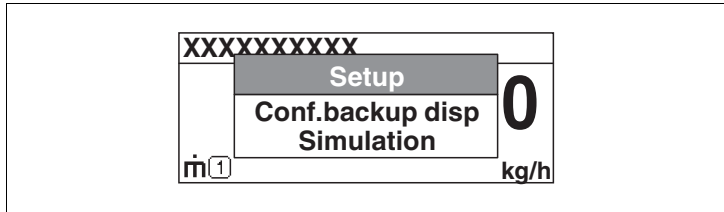

Figure 9.2

2. Press **[−]** and **[+]** simultaneously.

↳ The context menu is closed and the operational display appears.

Calling up the menu via the context menu

1. Open the context menu.
2. Press **[+]** to navigate to the desired menu.
3. Press **[E]** to confirm the selection.

↳ The selected menu opens.



## 9.2 Operating menu

| Parameter/Submenu             | Meaning  | Description  |
|-------------------------------|--|--|
| <b>Language</b> <sup>a</sup>  | Defines the operating language of the on-site display.   | Manual   |
| <b>Setup</b>                  | When appropriate values have been assigned to all setup parameters, the measured should be completely configured in a standard application.  |  |
| <b>Setup → Mapping</b>        | Interference echo suppression  |  |
| <b>Setup → Advanced setup</b> | Contains further submenus and parameters: <ul style="list-style-type: none"> <li>• to adapt the device to special measuring conditions.</li> <li>• to process the measured value (scaling, linearization).</li> <li>• to configure the signal output.</li> </ul> |  |
| <b>Diagnostics</b>            | Contains the most important parameters needed to detect and analyze operational errors.  |  |
| <b>Expert</b> <sup>b</sup>    | Contains all parameters of the device (including those which are already contained in one of the above submenus). This menu is organized according to the function blocks of the device.   | GP01001O/98/DE (Description of Device Parameters LTC5X, PROFIBUS PA) |

Table 9.2

<sup>a</sup> In case of operation via operating tools (e. g. PACTware), the "Language" parameter is located at Setup → Advanced setup → Display.

<sup>b</sup> On entering the **Expert** menu, an access code is always requested. If a customer specific access code has not been defined, "0000" has to be entered.

## 9.3 Unlock the device

If the device has been locked, it must be unlocked before the measurement can be configured.



**Note!**

For details refer to the manuals of the device.

## 9.4 Setting the operating language

Factory setting: English or ordered local language

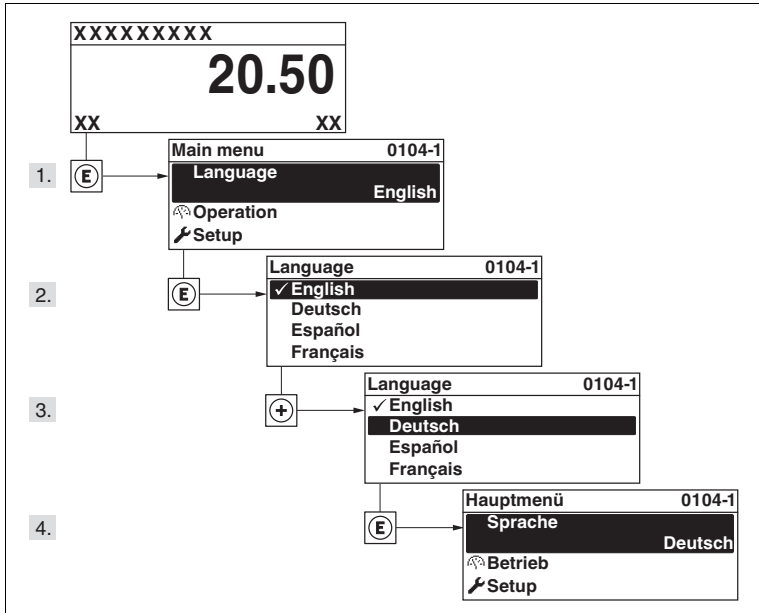

Figure 9.3 Example: local display

## 9.5 Configuration of a level measurement

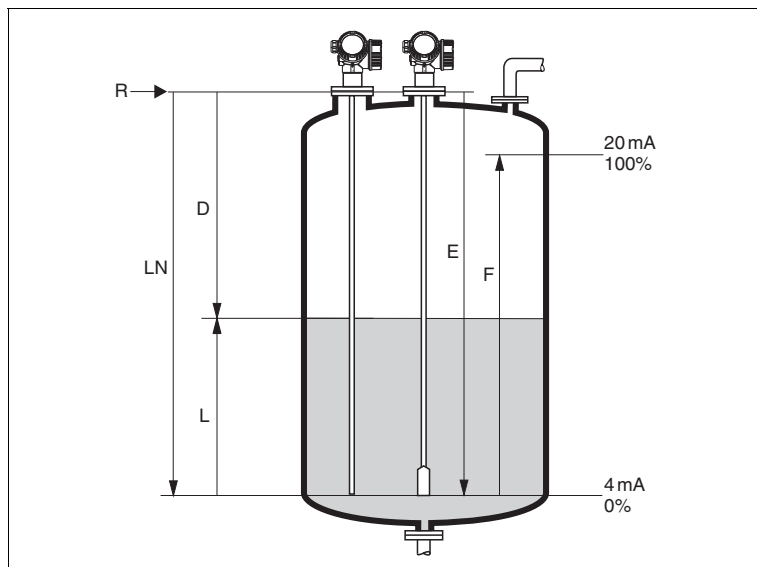

Figure 9.4 Configuration parameters for level measurements in liquids

- LN** Probe length
- D** Distance
- L** Level
- R** Reference point of measurement
- E** Empty calibration (= zero)
- F** Full calibration (= span)



### Configuring level measurement

1. Setup menu → Device tag
  - ↳ Enter tag for measuring point.
2. Navigate to: Setup menu → Device
  - ↳ Enter the bus address of the device (only for software addressing).
3. Navigate to: Setup menu → Distance unit.
  - ↳ Select distance unit.
4. Navigate to: Setup menu → Tank type
  - ↳ Select tank type.
5. For **Tank type** parameter = Bypass/pipe:  
Navigate to Setup menu → Tube diameter
  - ↳ Enter the diameter of the bypass or stilling well.
6. Navigate to: Setup menu → Medium group.
  - ↳ Select medium group: (**Water based (DC >= 4)** or **Others**)
7. Navigate to: Setup menu → Empty calibration
  - ↳ Enter the distance E between the reference point R and the minimum level (0 %).
8. Navigate to: Setup menu → Full calibration.
  - ↳ Enter distance F between the minimum (0 %) and maximum (100 %) level.
9. Navigate to: Setup menu → Level.
  - ↳ Displays the measured level L.
10. Navigate to: Setup menu → Distance.
  - ↳ Displays the distance D between the reference point R and the level L.
11. Navigate to: Setup menu → Signal quality.
  - ↳ Displays the signal quality of the level echo.
12. For operation via local display:  
Navigate to: Setup menu → Mapping → Mapping → Confirm distance
  - ↳ Compare the displayed distance to the real distance in order to start the recording of the mapping curve if required.
13. For operation via operating tool:  
Navigate to: Setup menu → Mapping → Confirm distance
  - ↳ Compare the displayed distance to the real distance in order to start the recording of the mapping curve if required.

## 9.6 User-specific applications



**Note!**

For details of setting the parameters of user-specific applications, see separate documentation.



**Note!**

For the **Expert** submenu refer to: GP01001O/98/EN (Description of Device Parameters LTC5X, PROFIBUS PA)





# PROCESS AUTOMATION – PROTECTING YOUR PROCESS



## Worldwide Headquarters

Pepperl+Fuchs GmbH  
68307 Mannheim · Germany  
Tel. +49 621 776-0  
E-mail: [info@de.pepperl-fuchs.com](mailto:info@de.pepperl-fuchs.com)

For the Pepperl+Fuchs representative  
closest to you check [www.pepperl-fuchs.com/contact](http://www.pepperl-fuchs.com/contact)

[www.pepperl-fuchs.com](http://www.pepperl-fuchs.com)

Subject to modifications  
Copyright PEPPERL+FUCHS • Printed in Germany



71211924

KA010790/98/EN/14.15

 **PEPPERL+FUCHS**  
PROTECTING YOUR PROCESS

274502

DOCT-3990  
04/2015