

## MANUAL

# LMC-P, LMC-S, LMC-Ex Magnetic Immersion Probe for Continuous Measurement



With regard to the supply of products, the current issue of the following document is applicable: The General Terms of Delivery for Products and Services of the Electrical Industry, published by the Central Association of the Electrical Industry (Zentralverband Elektrotechnik und Elektroindustrie (ZVEI) e.V.) in its most recent version as well as the supplementary clause: "Expanded reservation of proprietorship"

<b>1</b>	<b>Introduction</b>	<b>2</b>
1.1	Contents	2
1.2	Target Group, Personnel	3
1.3	Symbols Used	3
<b>2</b>	<b>Product Specifications</b>	<b>5</b>
2.1	Function	5
2.2	Assembly	6
<b>3</b>	<b>Goods Acceptance</b>	<b>7</b>
<b>4</b>	<b>Mounting and Installation</b>	<b>8</b>
4.1	Checking the Device Function before Mounting	8
4.2	Mounting	9
4.3	Connection	11
<b>5</b>	<b>Operation</b>	<b>13</b>
5.1	Checking the Device Function	13
<b>6</b>	<b>Troubleshooting</b>	<b>14</b>
<b>7</b>	<b>Maintenance</b>	<b>15</b>
<b>8</b>	<b>Repair, Return, and Disposal</b>	<b>16</b>
<b>9</b>	<b>Technical Specifications</b>	<b>17</b>
9.1	Technical Specifications	17
9.2	Dimensions	20

# 1 Introduction

## 1.1 Contents

This document contains information that you need in order to use your product throughout the applicable stages of the product life cycle. These can include the following:

- Product identification
- Delivery, transport, and storage
- Mounting and installation
- Commissioning and operation
- Maintenance and repair
- Troubleshooting
- Dismounting
- Disposal



**Note!**

This document does not substitute the instruction manual.



**Note!**

For full information on the product, refer to the instruction manual and further documentation on the Internet at [www.pepperl-fuchs.com](http://www.pepperl-fuchs.com).

The documentation consists of the following parts:

- Present document
- Instruction manual
- Datasheet

Additionally, the following parts may belong to the documentation, if applicable:

- EC-type of examination
- EU declaration of conformity
- Attestation of conformity
- Certificates
- Control drawings
- Additional documents

## 1.2 Target Group, Personnel

Responsibility for planning, assembly, commissioning, operation, maintenance, and dismantling lies with the plant operator.

Only appropriately trained and qualified personnel may carry out mounting, installation, commissioning, operation, maintenance, and dismantling of the product. The personnel must have read and understood the instruction manual and the further documentation.

Prior to using the product make yourself familiar with it. Read the document carefully.

## 1.3 Symbols Used

This document contains symbols for the identification of warning messages and of informative messages.

### Warning Messages

You will find warning messages, whenever dangers may arise from your actions. It is mandatory that you observe these warning messages for your personal safety and in order to avoid property damage.

Depending on the risk level, the warning messages are displayed in descending order as follows:



#### ***Danger!***

This symbol indicates an imminent danger.

Non-observance will result in personal injury or death.



#### ***Warning!***

This symbol indicates a possible fault or danger.

Non-observance may cause personal injury or serious property damage.



#### ***Caution!***

This symbol indicates a possible fault.

Non-observance could interrupt the device and any connected systems and plants, or result in their complete failure.

### Informative Symbols



**Note!**

This symbol brings important information to your attention.



**Action**

This symbol indicates a paragraph with instructions. You are prompted to perform an action or a sequence of actions.

## 2 Product Specifications

### 2.1 Function

The device is a sensor for continuous level measurement in liquids.

A ring magnet integrated in the float activates a reed contact resistance chain inside the probe tube via its magnetic field. If the level changes, the resistance chain changes its total resistance by closing the contact at the float level. The resistance is converted into a standardized output signal by a control unit. This output signal is proportional to the level of the measured medium.

The maximum sliding tube length is 3000 mm.

#### **Magnetic immersion probe LMC-P**

The sliding tube and process connection are made from plastic.

#### **Magnetic immersion probe LMC-S**

The sliding tube and process connection are made from stainless steel.

#### **Magnetic immersion probe LMC-Ex**

The device is intended for use in explosion-hazardous areas.

The sliding tube and process connection are made from stainless steel.



#### ***Note!***

For more information see the corresponding datasheets.

2.2

Assembly

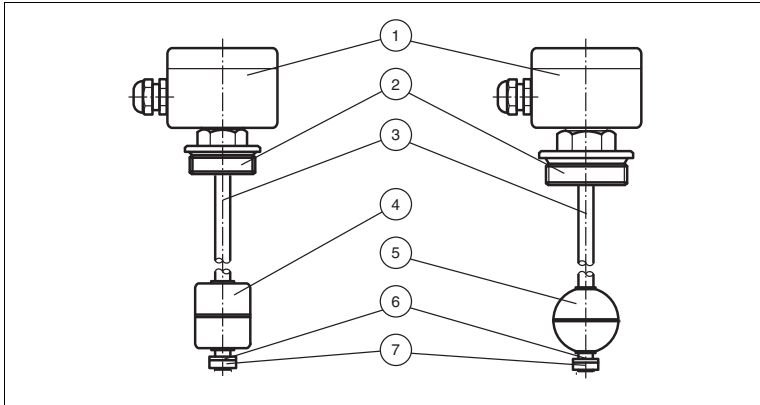

Figure 2.1

- 1 Terminal box
- 2 Process connection, e. g. thread
- 3 Sliding tube
- 4 Float - cylinder
- 5 Float - ball
- 6 Drop protection ring of Teflon
- 7 Set collar



### 3

## Goods Acceptance



Removing the Device from the Transport Packaging and Checking the Device

1. Remove the transport restraints.
2. Carefully remove the device from the shipping packaging.
3. Remove the packaging parts from the device.
4. Check that the order designations on the delivery note and nameplate are identical.
5. Check to ensure the device is not damaged.
6. Check that the float can be easily moved along the sliding tube.



**Note!**

If any of these conditions are not met, contact your Pepperl+Fuchs distribution center.

## 4 Mounting and Installation

### 4.1 Checking the Device Function before Mounting

You have the option of testing the device before it is mounted in the container. To do this, use an ohmmeter.

Checking the Device Function

1. Connect an ohmmeter to the device, see following table.
2. Move the float from the minimum to the maximum position.

↳ The indicated resistance value changes depending on the version of connection, see following table.

General	3-wire, potentiometer connection	
Black-Brown ( $R_1$ )	Blue-Brown ( $R_2$ )	Black-Blue ( $R_i$ <sup>1</sup> )
The resistance value increases proportionally to the height of the rising magnet system (float). Magnet system (float) at the top – indication of the total resistance ( $R_i$ )	The resistance value drops proportionally to the height of the rising magnet system (float). Magnet system (float) at the bottom – indication of the total resistance ( $R_i$ )	Indication of the total resistance ( $R_i$ )

Table 4.1 Function check with ohmmeter, indication of the resistance value depending on the version of connection

<sup>1</sup>  $R_i$  see datasheet

## 4.2 Mounting



### **Danger!**

Danger to life from working in containers

In containers, hazardous substances may be present that can result in poisoning or suffocation.

- Eliminate or reduce hazardous substances.
- Protect persons that come in contact with hazardous substances by means of suitable protective measures, e. g., by respiratory devices or protective clothing.



### **Danger!**

Explosion hazard from sparking when using the device

Improper use of the device in a potentially explosive atmosphere can cause sparks that can ignite the surrounding atmosphere.

- Do not remove the drop protection rings.  
Drop protection rings of teflon prevent sparking on impact of the float on the set collar. Operating the device without drop protection rings is prohibited.
- If you are using floats of titanium: Keep the maximum permissible ambient temperature by ensuring a sufficient distance between the process connection and the medium.



### Mounting the Device

1. Observe the safety information given in the instruction manual.
2. Prior to installation, ensure that the installation opening on the container and the securing device on the float match in terms of size and dimensioning.
3. Install the device in the container from the outside. The device is installed in a vertical position. The angle of installation must not deviate from the vertical position by more than 30°, see Figure 4.1.
4. Screw in the device using the full length of the thread (1). Use suitable seals.

For variants with floats fitted that are larger in diameter than the core diameter of the installation opening, proceed as follows.

### Mounting the Device

1. Mark the top of the float (4) (e. g. with "top").
2. Mark the position of the set collars to be removed (6).
3. Remove the set collars (6) and drop protection rings (5).
4. Remove the float (4).
5. Install the device.
6. Install the float (4), set collars (6) and drop protection rings (5) from inside the container. Pay attention to the markings.

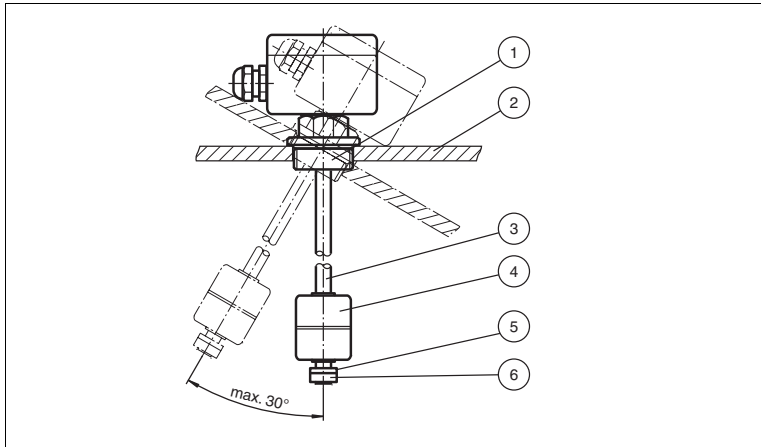

Figure 4.1 Principal device mounting

- 1 Process connection
- 2 Container
- 3 Sliding tube
- 4 Float
- 5 Drop protection ring
- 6 Set collar



### **Note!**

Further information can be found in the chapter "Dimensions", see page 20.

## 4.3 Connection



### ***Danger!***

Danger to life from electric shock

Working on live parts at voltages higher than 50 V AC or 120 V DC can result in electric shock.

1. De-energize the device.
2. Secure the circuit against reconnection.
3. Verify that the device is de-energized at all poles.
4. Provide protection from adjacent live parts, if present.



### ***Danger!***

Danger to life from incorrect installation

Incorrect installation of cables and connection lines can compromise the function and the electrical safety of the device.

- Observe the permissible core cross-section of the conductor.
- When using stranded conductors, crimp wire end ferrules on the conductor ends.
- Use only one conductor per terminal.
- When installing the conductors the insulation must reach up to the terminal.
- Observe the tightening torque of the terminal screws.



### Connecting the Device

1. Observe the safety information given in the instruction manual.
2. Remove the cover on the terminal box.
3. Route the cable through the cable gland into the terminal box.
4. Connect the conductors in the terminals as required for the relevant application, see following figures.
5. Refit the cover of the terminal box.

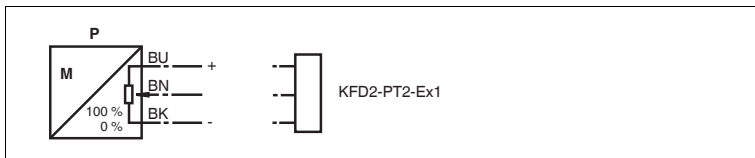

Figure 4.2 Connection of magnetic immersion probe LMC-P

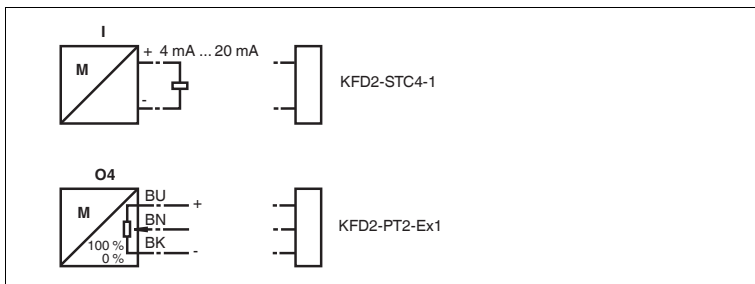

Figure 4.3 Connection of magnetic immersion probe LMC-S

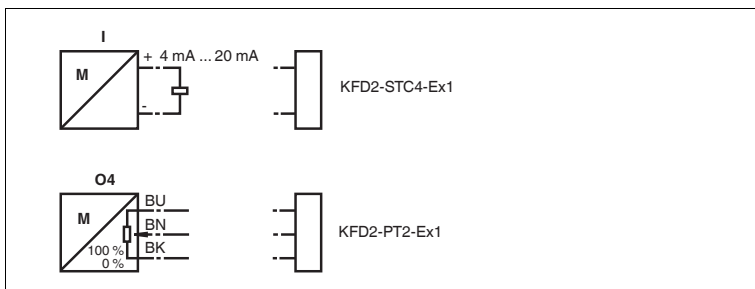

Figure 4.4 Connection of magnetic immersion probe LMC-Ex

**BK** Black  
**BN** Brown  
**BU** Blue



### Establishing Equipotential Bonding

A PE terminal is available in the terminal box for the device.

1. For devices without grounding terminal: Establish an electrical connection to the container via the process connection.
2. For devices with grounding terminal: Establish equipotential bonding via the grounding terminal.

## 5 Operation

### 5.1 Checking the Device Function



#### ***Danger!***

Danger to life from electric shock

Working on live parts at voltages higher than 50 V AC or 120 V DC can result in electric shock.

1. De-energize the device.
2. Secure the circuit against reconnection.
3. Verify that the device is de-energized at all poles.
4. Provide protection from adjacent live parts, if present.



#### Checking the Device Function

When the device is installed, a functional check is not possible. Remove the device to check the function.

1. Disconnect the circuit.
2. Remove the device from the container.
3. Perform a functional inspection on the device as described in the chapter "Checking the Device Function before Mounting", see chapter 4.1.
4. Place the device in the container.
5. Connect the device.

## 6 Troubleshooting

The following table lists the most frequent causes of malfunctions and the necessary countermeasures.

Malfunction	Possible cause	Corrective action
No switching function or undefined switching function	False terminal connection	Compare with connection diagram, see chapter 4.3
	Insulation	Check terminals
	Set collars out of position or replaced incorrectly after the sliding tube is removed.	Control position of set collar
	Reed contact defective due to mechanical vibrations.	Return to the manufacturer, see chapter 8
False values (0 % ... 100 %)	Float installed incorrectly.	Turn float around.
	False ordering information	Please contact the manufacturer.
	Signal converter falsely adjusts	Signal converter adjust or please contact the manufacturer.
Device cannot be attached at the intended position on the container	Thread or flange dimensions of the device do not agree.	Reworking of container
		Reworking of device by the manufacturer, see chapter 8
	Thread of mounting plug on container defective.	Reworking of thread or replacement of mounting plug
	Bolt threading on the device defective.	Return to the manufacturer, see chapter 8

Table 6.1



**Note!**

Please contact Pepperl+Fuchs for more information.



## 7 Maintenance



### **Danger!**

Danger to life from working in containers

In containers, hazardous substances may be present that can result in poisoning or suffocation.

- Eliminate or reduce hazardous substances.
- Protect persons that come in contact with hazardous substances by means of suitable protective measures, e. g., by respiratory devices or protective clothing.

The device is maintenance free.



### Checking the Condition of the Device

1. Visually check the condition of the device as part of regular inspection work.
2. Include the device when pressure testing the container.



### **Note!**

For more information see the corresponding datasheets.



### Cleaning the Device

1. Clean the device as necessary.
2. Take care not to damage the device.

## 8 Repair, Return, and Disposal

### Repair



#### ***Danger!***

Danger to life from using damaged or repaired devices.

Using a defective or repaired device can compromise its function and its electrical safety.

- Do not use a damaged or polluted device.
- The device must not be repaired, changed or manipulated.
- If there is a defect, always replace the device with an original device from Pepperl+Fuchs.

### Return

If there is a defect, always send back the device to Pepperl+Fuchs.

Take the following precautions before you return the device to Pepperl+Fuchs.

- Remove all adhering residues from the device. These residues can be hazardous to health.
- Fill in the form "Declaration of Contamination". You can find this form on the product detail page at [www.pepperl-fuchs.com](http://www.pepperl-fuchs.com).
- Enclose the filled in "Declaration of Contamination" form with the device.
- Pepperl+Fuchs can examine and repair a returned device, only if a completed form is included in the return.

If needed, include special handling instructions with the device.

Specify the following information:

- Chemical and physical characteristics of the product
- Description of the application
- Description of the error that occurred (specify error code if possible)
- Operating time of the device

### Disposal

Observe the following notes during disposal:

- Observe valid federal/national regulations.
- Ensure proper separation and reuse of the device components.

## 9 Technical Specifications

### 9.1 Technical Specifications

#### Magnetic Immersion Probe LMC-P

<b>Output</b>	
Connection	3-wire, potentiometer connection approx. 40 kΩ
<b>Directive conformity</b>	
Electromagnetic compatibility	
Directive 2014/30/EU	EN 61326-1:2013 , EN 61326-2-3:2013
<b>Conformity</b>	
Degree of protection	IEC 60529:2000
<b>Measurement accuracy</b>	
Resolution	10 mm
<b>Operating conditions</b>	
Process conditions	
Process temperature	<ul style="list-style-type: none"> <li>• version PP: -10 ... 80 °C (14 ... 176 °F)</li> <li>• version PVDF: -10 ... 100 °C (14 ... 212 °F)</li> </ul>
Process pressure (static pressure)	≤ 3 bar (43.5 psi)
Density	≥ 0.8 g/cm <sup>3</sup>
<b>Ambient conditions</b>	
Ambient temperature	-20 ... 70 °C (-4 ... 158 °F)

Table 9.1

**Magnetic Immersion Probe LMC-S**

<b>Output</b>	
Connection	<ul style="list-style-type: none"> <li>• version I: 2-wire, 4 ... 20 mA</li> <li>• version O4: 3-wire, potentiometer connection approx. 40 k<math>\Omega</math></li> </ul>
<b>Directive conformity</b>	
Electromagnetic compatibility	
Directive 2014/30/EU	EN 61326-1:2013 , EN 61326-2-3:2013
<b>Conformity</b>	
Degree of protection	IEC 60529:2000
<b>Measurement accuracy</b>	
Resolution	<ul style="list-style-type: none"> <li>• version LMC5: 5 mm</li> <li>• version LMC15: 15 mm</li> </ul>
<b>Operating conditions</b>	
Process conditions	
Process temperature	-20 ... 120 °C (-4 ... 248 °F)
Process pressure (static pressure)	$\leq$ 16 bar (323.1 psi)
Density	<ul style="list-style-type: none"> <li>• version S1: <math>\geq</math> 0.6 g/cm<sup>3</sup></li> <li>• version S2: <math>\geq</math> 0.8 g/cm<sup>3</sup></li> <li>• version S3: <math>\geq</math> 0.7 g/cm<sup>3</sup></li> </ul>
<b>Ambient conditions</b>	
Ambient temperature	-20 ... 70 °C (-4 ... 158 °F)

Table 9.2

EN

**Magnetic Immersion Probe LMC-Ex**

EN

<b>Output</b>	
Connection	<ul style="list-style-type: none"> <li>version I: 2-wire, 4 ... 20 mA</li> <li>version O4: 3-wire, potentiometer connection approx. 40 k<math>\Omega</math></li> </ul>
<b>Directive conformity</b>	
Electromagnetic compatibility	
Directive 2014/30/EU	EN 61000-6-2:2006 , EN 61000-6-4:2011
<b>Conformity</b>	
Degree of protection	IEC 60529:2000
<b>Measurement accuracy</b>	
Resolution	<ul style="list-style-type: none"> <li>version LMC5: 5 mm</li> <li>version LMC15: 15 mm</li> </ul>
<b>Operating conditions</b>	
Process conditions	
Process temperature	-20 ... 100 °C (-4 ... 212 °F)
Process pressure (static pressure)	$\leq$ 16 bar (323.1 psi)
Density	<ul style="list-style-type: none"> <li>version S1: <math>\geq</math> 0.6 g/cm<sup>3</sup></li> <li>version S2: <math>\geq</math> 0.8 g/cm<sup>3</sup></li> <li>version S3: <math>\geq</math> 0.7 g/cm<sup>3</sup></li> </ul>
<b>Ambient conditions</b>	
Ambient temperature	terminal box: -50 ... 60 °C (-58 ... 140 °F)
<b>Data for application in connection with Ex-areas</b>	
EC-Type Examination Certificate	KEMA 03 ATEX 1497 X
Group, category, type of protection, temperature class	II 1/2G EEx ia IIC T4...T6
Voltage U <sub>i</sub>	28 V
Current I <sub>i</sub>	120 mA
Internal capacitance C <sub>i</sub>	0 nF
Internal inductance L <sub>i</sub>	0 $\mu$ H
Directive conformity	
Directive 2014/34/EU	EN 60079-0:2012, EN 60079-11:2012, EN 60079-26:2007

Table 9.3



**Note!**

For more information see the corresponding datasheets.

## 9.2 Dimensions

### 9.2.1 Magnetic Immersion Probe LMC-P

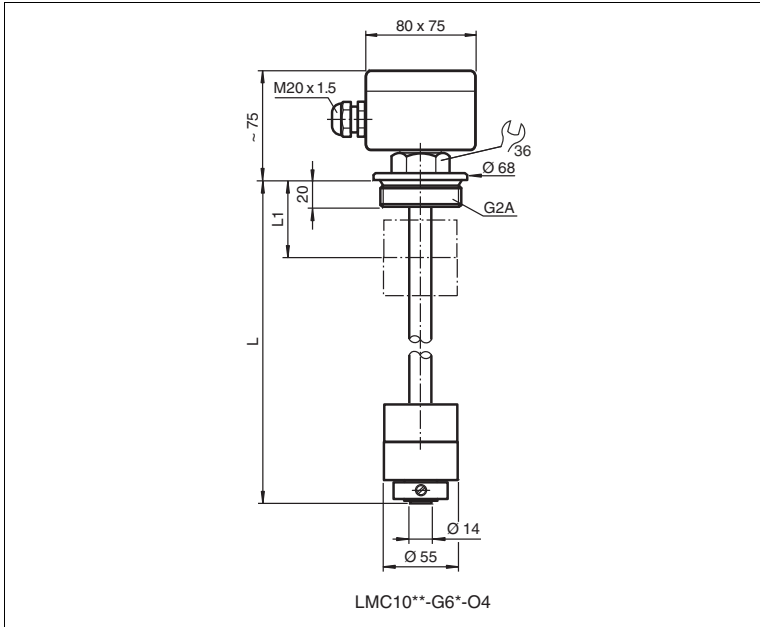

Figure 9.1

L Specified length, max. 3000 mm

### 9.2.2 Magnetic Immersion Probe LMC-S

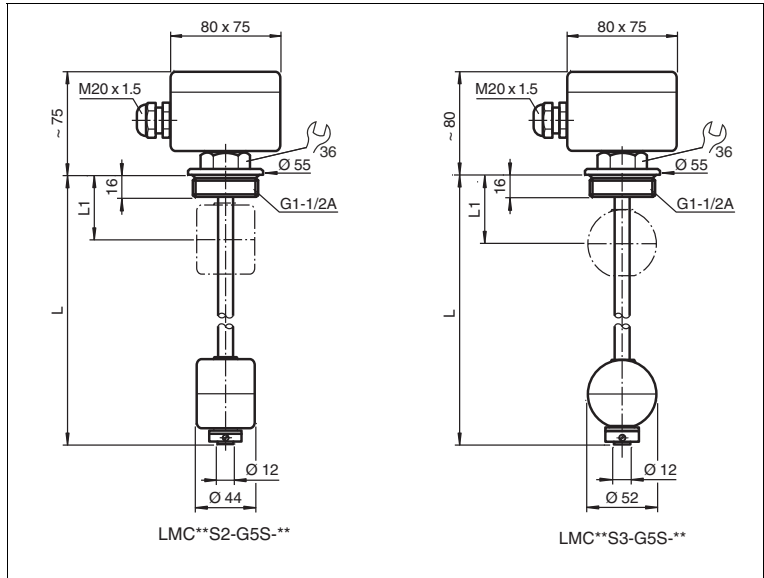

Figure 9.2

L Specified length, max. 3000 mm

9.2.3

Magnetic Immersion Probe LMC-Ex

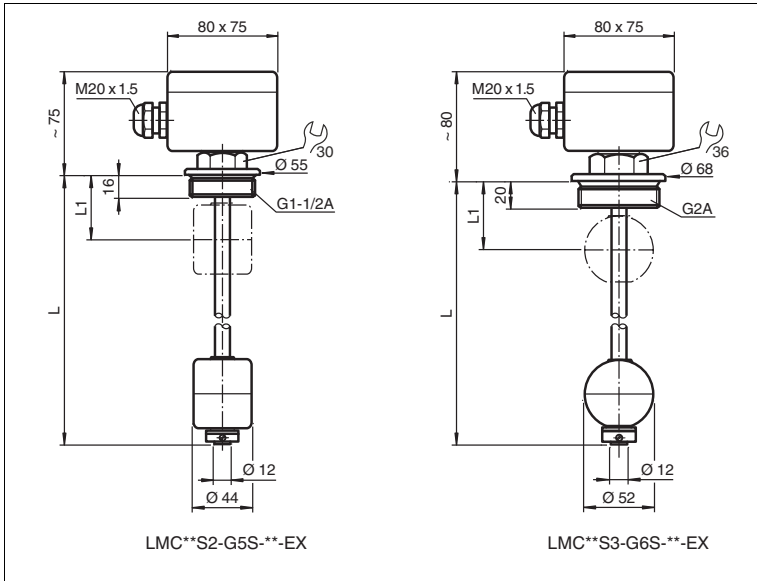

Figure 9.3

L Specified length, max. 3000 mm





# PROCESS AUTOMATION – PROTECTING YOUR PROCESS



## Worldwide Headquarters

Pepperl+Fuchs GmbH  
68307 Mannheim · Germany  
Tel. +49 621 776-0  
E-mail: [info@de.pepperl-fuchs.com](mailto:info@de.pepperl-fuchs.com)

For the Pepperl+Fuchs representative  
closest to you check [www.pepperl-fuchs.com/contact](http://www.pepperl-fuchs.com/contact)

[www.pepperl-fuchs.com](http://www.pepperl-fuchs.com)

Subject to modifications  
Copyright PEPPERL+FUCHS • Printed in Germany

 **PEPPERL+FUCHS**  
*PROTECTING YOUR PROCESS*

289818

DOCT-5036A  
04/2016