

# MANUAL

## Functional Safety Current Driver/Repeater HiD2035, HiD2036



**SIL 2**



With regard to the supply of products, the current issue of the following document is applicable: The General Terms of Delivery for Products and Services of the Electrical Industry, published by the Central Association of the Electrical Industry (Zentralverband Elektrotechnik und Elektroindustrie (ZVEI) e.V.) in its most recent version as well as the supplementary clause: "Expanded reservation of proprietorship"

<b>1</b>	<b>Introduction</b>	<b>4</b>
1.1	Contents	4
1.2	Safety Information	5
1.3	Symbols Used	5
<b>2</b>	<b>Product Description</b>	<b>7</b>
2.1	Function	7
2.2	Interfaces	7
2.3	Marking	7
2.4	Standards and Directives for Functional Safety	8
<b>3</b>	<b>Planning</b>	<b>9</b>
3.1	System Structure	9
3.2	Assumptions	10
3.3	Safety Function and Safe State	11
3.4	Characteristic Safety Values	12
3.5	Useful Life Time	13
<b>4</b>	<b>Mounting and Installation</b>	<b>14</b>
4.1	Configuration	14
<b>5</b>	<b>Operation</b>	<b>15</b>
5.1	Proof Test Procedure	15
<b>6</b>	<b>Maintenance and Repair</b>	<b>18</b>
<b>7</b>	<b>List of Abbreviations</b>	<b>19</b>

# 1 Introduction

## 1.1 Contents

This document contains information for usage of the device in functional safety-related applications. You need this information to use your product throughout the applicable stages of the product life cycle. These can include the following:

- Product identification
- Delivery, transport, and storage
- Mounting and installation
- Commissioning and operation
- Maintenance and repair
- Troubleshooting
- Dismounting
- Disposal



**Note!**

This document does not substitute the instruction manual.



**Note!**

For full information on the product, refer to the instruction manual and further documentation on the Internet at [www.pepperl-fuchs.com](http://www.pepperl-fuchs.com).

The documentation consists of the following parts:

- Present document
- Instruction manual
- Manual
- Datasheet

Additionally, the following parts may belong to the documentation, if applicable:

- EC-type of examination
- EU declaration of conformity
- Attestation of conformity
- Certificates
- Control drawings
- FMEDA report
- Assessment report
- Additional documents

For more information about functional safety products from Pepperl+Fuchs see [www.pepperl-fuchs.com/sil](http://www.pepperl-fuchs.com/sil).

## 1.2 Safety Information

### Target Group, Personnel

Responsibility for planning, assembly, commissioning, operation, maintenance, and dismantling lies with the plant operator.

Only appropriately trained and qualified personnel may carry out mounting, installation, commissioning, operation, maintenance, and dismantling of the product. The personnel must have read and understood the instruction manual and the further documentation.

### Intended Use

The device is only approved for appropriate and intended use. Ignoring these instructions will void any warranty and absolve the manufacturer from any liability.

The device is developed, manufactured and tested according to the relevant safety standards.

Use the device only

- for the application described
- with specified environmental conditions
- with devices that are suitable for this safety application

### Improper Use

Protection of the personnel and the plant is not ensured if the device is not used according to its intended use.

## 1.3 Symbols Used

This document contains symbols for the identification of warning messages and of informative messages.

### Warning Messages

You will find warning messages, whenever dangers may arise from your actions. It is mandatory that you observe these warning messages for your personal safety and in order to avoid property damage.

Depending on the risk level, the warning messages are displayed in descending order as follows:



***Danger!***

This symbol indicates an imminent danger.

Non-observance will result in personal injury or death.



***Warning!***

This symbol indicates a possible fault or danger.

Non-observance may cause personal injury or serious property damage.



***Caution!***

This symbol indicates a possible fault.

Non-observance could interrupt the device and any connected systems and plants, or result in their complete failure.

**Informative Symbols**



***Note!***

This symbol brings important information to your attention.



**Action**

This symbol indicates a paragraph with instructions. You are prompted to perform an action or a sequence of actions.

## 2 Product Description

### 2.1 Function

This isolated barrier is used for intrinsic safety applications.

The device repeats the 1.5 mA ... 50 mA input signal from a control system to drive fire and smoke alarms on the field side.

The device drives also I/P converters on the field side.

An open field circuit presents a high impedance to the control side to allow alarm conditions to be monitored by control systems.

The device is loop powered. From the control side no additional power supply has to be connected.

A reverse polarity protection prevents damage to the device caused by faulty wiring.

This device mounts on a HiD Termination Board.

### 2.2 Interfaces

The device has the following interfaces.

- Safety relevant interfaces:
  - 1-channel devices: input I, output I
  - 2-channel devices: input I, input II, output I, output II
- Non-safety relevant interfaces: none



**Note!**

For corresponding connections see datasheet.

### 2.3 Marking

Pepperl+Fuchs GmbH Lilienthalstraße 200, 68307 Mannheim, Germany
---

HiD2035, HiD2036	Up to SIL 2
------------------	-------------

## 2.4 Standards and Directives for Functional Safety

### Device-specific standards and directives

Functional safety	IEC/EN 61508, part 2, edition 2010: Functional safety of electrical/electronic/programmable electronic safety-related systems (manufacturer)
-------------------	---

### System-specific standards and directives

Functional safety	IEC/EN 61511, part 1 – 3, edition 2003: Functional safety – Safety instrumented systems for the process industry sector (user)
-------------------	--



## 3 Planning

### 3.1 System Structure

#### 3.1.1 Low Demand Mode of Operation

If there are two control loops, one for the standard operation and another one for the functional safety, then usually the demand rate for the safety loop is assumed to be less than once per year.

The relevant safety parameters to be verified are:

- the  $PFD_{avg}$  value (average **P**robability of dangerous **F**ailure on **D**emand) and the  $T_1$  value (proof test interval that has a direct impact on the  $PFD_{avg}$  value)
- the SFF value (**S**afe **F**ailure **F**raction)
- the HFT architecture (**H**ardware **F**ault **T**olerance)

#### 3.1.2 High Demand or Continuous Mode of Operation

If there is only one safety loop, which combines the standard operation and safety-related operation, then usually the demand rate for this safety loop is assumed to be higher than once per year.

The relevant safety parameters to be verified are:

- the PFH value (**P**robability of dangerous **F**ailure per **H**our)
- Fault reaction time of the safety system
- the SFF value (**S**afe **F**ailure **F**raction)
- the HFT architecture (**H**ardware **F**ault **T**olerance)

#### 3.1.3 Safe Failure Fraction

The safe failure fraction describes the ratio of all safe failures and dangerous detected failures to the total failure rate.

$$SFF = (\lambda_s + \lambda_{dd}) / (\lambda_s + \lambda_{dd} + \lambda_{du})$$

A safe failure fraction as defined in IEC/EN 61508 is only relevant for elements or (sub)systems in a complete safety loop. The device under consideration is always part of a safety loop but is not regarded as a complete element or subsystem.

For calculating the SIL of a safety loop it is necessary to evaluate the safe failure fraction of elements, subsystems and the complete system, but not of a single device.

Nevertheless the SFF of the device is given in this document for reference.

## 3.2 Assumptions

The following assumptions have been made during the FMEDA:

- The device shall claim less than 10 % of the total failure budget for a SIL 2 safety loop.
- For a SIL 2 application operating in low demand mode the total  $PFD_{avg}$  value of the SIF (**S**afety **I**nstrumented **F**unction) should be smaller than  $10^{-2}$ , hence the maximum allowable  $PFD_{avg}$  value would then be  $10^{-3}$ .
- For a SIL 2 application operating in high demand mode the total PFH value of the SIF should be smaller than  $10^{-6}$  per hour, hence the maximum allowable PFH value would then be  $10^{-7}$  per hour.
- Failure rate based on the Siemens standard SN29500.
- Failure rates are constant, wear is not considered.
- External power supply failure rates are not included.
- The safety-related device is considered to be of type **A** device with a hardware fault tolerance of **0**.
- Since the safety loop has a hardware fault tolerance of **0** and it is a type **A** device, the SFF must be > 60 % according to table 2 of IEC/EN 61508-2 for a SIL 2 (sub) system.
- The device will be used under average industrial ambient conditions, which are comparable with the classification "stationary mounted" in MIL-HDBK-217F. Alternatively, the following ambient conditions are assumed:
  - IEC/EN 60654-1 Class C (sheltered location) with temperature limits in the range of the manufacturer's specifications and an average temperature of 40 °C over a long period. The humidity level is within manufacturer's rating. For a higher average temperature of 60 °C, the failure rates must be multiplied by a factor of 2.5 based on experience. A similar factor must be used if frequent temperature fluctuations are expected.
- The application program in the programmable logic controller (PLC) is configured to detect underrange and overrange failures.
- The devices are not protected against power supply failures. It is within the responsibility of the user to ensure that low supply voltages are detected and adequate reaction on this fault is implemented.

### 3.3 Safety Function and Safe State

#### Safe State

The safe state depends on the respective application. When the output values are below 3.6 mA or above 50 mA, the device indicates failures that are considered as dangerous detected.

#### Safety Function

The device transfers a current from the field side to the control side with an accuracy of  $\pm 1$  mA.

#### Reaction Time

The reaction time for all safety functions is  $< 100$  ms.



#### **Note!**

For more information see the corresponding datasheets.

### 3.4 Characteristic Safety Values

#### HiD2035, HiD2036, 1oo1 Structure

Parameters acc. to IEC 61508	Characteristic values
Assessment type and documentation	FMEDA report
Device type	A
Mode of operation	Low Demand Mode or High Demand Mode
HFT	0
SIL (SC)	2
Safety function	Current transfer from the field side to the control side
$\lambda_{sd} + \lambda_{su}^1$	0 FIT
$\lambda_{dd}$	124 FIT
$\lambda_{du}^1$	71 FIT
$\lambda_{total}$ (safety function)	194 FIT
$\lambda_{not\ part}$	0 FIT
SFF	63 %
PTC	100 %
MTBF <sup>2</sup>	298 years
PFH	$7.06 \times 10^{-8}$ 1/h
PFD <sub>avg</sub> for $T_1 = 1$ year	$3.09 \times 10^{-4}$
PFD <sub>avg</sub> for $T_1 = 2$ years	$6.18 \times 10^{-4}$
PFD <sub>avg</sub> for $T_1 = 5$ years	$1.54 \times 10^{-3}$
Reaction time	< 100 ms

Table 3.1

- <sup>1</sup> "Not considered" failures are considered 50 % as dangerous undetected and 50 % as "No effect". "No effect" failures are not influencing the safety functions and are therefore not included in the calculation of the SFF.
- <sup>2</sup> acc. to SN29500. This value includes failures which are not part of the safety function/MTTR = 8 h. This value is calculated for one safety function of a device.

The characteristic safety values like PFD, SFF, HFT and  $T_1$  are taken from the SIL report/FMEDA report. Observe that PFD and  $T_1$  are related to each other.

The function of the devices has to be checked within the proof test interval ( $T_1$ ).

### 3.5 Useful Life Time

Although a constant failure rate is assumed by the probabilistic estimation this only applies provided that the useful lifetime of components is not exceeded. Beyond this useful lifetime, the result of the probabilistic estimation is meaningless as the probability of failure significantly increases with time. The useful lifetime is highly dependent on the component itself and its operating conditions – temperature in particular. For example, the electrolytic capacitors can be very sensitive to the operating temperature.

This assumption of a constant failure rate is based on the bathtub curve, which shows the typical behavior for electronic components.

Therefore it is obvious that failure calculation is only valid for components that have this constant domain and that the validity of the calculation is limited to the useful lifetime of each component.

It is assumed that early failures are detected to a huge percentage during the installation and therefore the assumption of a constant failure rate during the useful lifetime is valid.

However, according to IEC/EN 61508-2, a useful lifetime, based on general experience, should be assumed. Experience has shown that the useful lifetime often lies within a range period of about 8 ... 12 years.

As noted in DIN EN 61508-2:2011 note N3, appropriate measures taken by the manufacturer and plant operator can extend the useful lifetime.

Our experience has shown that the useful lifetime of a Pepperl+Fuchs product can be higher

- if there are no components with reduced life time in the safety loop (for example electrolytic capacitors, relays, flash memories, optocoupler) which can produce dangerous undetected failures and
- if the ambient temperature is significantly below 60 °C.

Please note that the useful lifetime refers to the (constant) failure rate of the device. The effective life time can be higher.

## 4 Mounting and Installation



Installing the device

1. Observe the safety instructions in the instruction manual.
2. Observe the information in the manual.
3. Observe the requirements for the safety loop.
4. Connect the device only to devices that are suitable for this safety application.
5. Check the safety function to ensure the expected output behavior.

### 4.1 Configuration

A configuration of the device is not necessary and not possible.

## 5 Operation



### **Danger!**

Danger to life from missing safety function

If the safety loop is put out of service, the safety function is no longer guaranteed.

- Do not deactivate the device.
- Do not bypass the safety function.
- Do not repair, modify, or manipulate the device.



Operating the device

1. Observe the safety instructions in the instruction manual.
2. Observe the information in the manual.
3. Use the device only with devices that are suitable for this safety application.
4. Correct any occurring safe failures within 8 hours. Take measures to maintain the safety function while the device is being repaired.

### 5.1 Proof Test Procedure

According to IEC/EN 61508-2 a recurring proof test shall be undertaken to reveal potential dangerous failures that are not detected otherwise.

Check the function of the subsystem at periodic intervals depending on the applied  $PFD_{avg}$  in accordance with the characteristic safety values. See chapter 3.4.

It is under the responsibility of the plant operator to define the type of proof test and the interval time period.

Equipment required:

- Digital multimeter with an accuracy better than 0.1 %  
Use for the proof test of the intrinsic safety side of the device a special digital multimeter for intrinsically safe circuits.  
If intrinsically safe circuits are operated with non-intrinsically safe circuits, they must no longer be used as intrinsically safe circuits.
- Variable power supply 0 V DC ... 30 V DC
- Process calibrator with current source and current sink function with an accuracy better than 20  $\mu$ A



**Proof Test Procedure**

1. Put out of service the entire safety loop. Protect the safety application by means of other measures.
2. Prepare a test set-up, see figures below.
3. Test the devices. Verify the current values as given in table below.
4. Set back the device to the original settings for the application after the test.

**HiD2035, HiD2036, 1oo1 Structure**

Step No.	Input value (V)	Input value (mA)	Measured input current (mA)
1	6	1.50	1.50 ± 0.5
2	14	4.00	4.00 ± 0.5
3	14	20.00	20.00 ± 0.5
4	22	10.00	10.00 ± 0.5
5	22	40.00	40.00 ± 0.5
6	30	5.00	5.00 ± 0.5
7	30	25.00	25.00 ± 0.5
8	30	50.00	50.00 ± 0.5

Table 5.1 Steps to be performed for the proof test

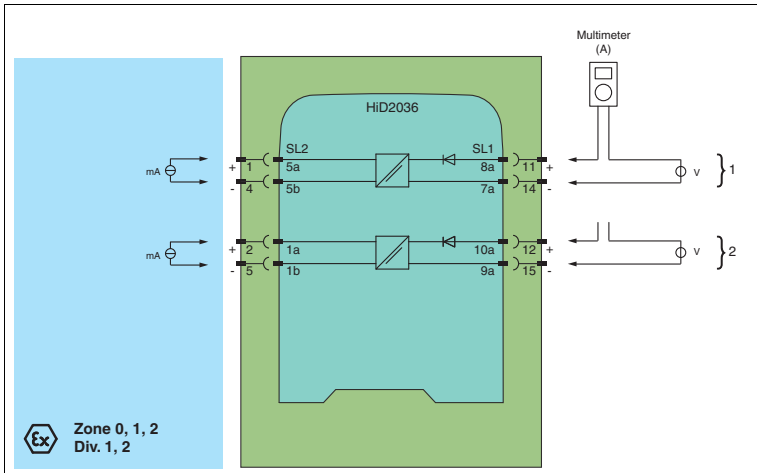

Figure 5.1 Proof test set-up for HiD2035, HiD2036

Channel 2 only for HiD2036





**Tip**

The easiest way to test HiD devices by using a stand-alone HiDTB\*\*-SCT-\*\*\*-\*\*-\*\* termination board. In this test, it is not necessary to disconnect the wiring of the existing application. Faults in a subsequent wiring can be avoided.

## 6 Maintenance and Repair



### ***Danger!***

Danger to life from missing safety function

If the safety loop is put out of service, the safety function is no longer guaranteed.

- Do not deactivate the device.
- Do not bypass the safety function.
- Do not repair, modify, or manipulate the device.



### Maintaining, Repairing or Replacing the Device

In case of maintenance, repair or replacement of the device, proceed as follows:

1. Implement appropriate maintenance procedures for regular maintenance of the safety loop.
2. Ensure the proper function of the safety loop, while the device is maintained, repaired or replaced.  
If the safety loop does not work without the device, shut down the application.  
Do not restart the application without taking proper precautions.  
Secure the application against accidental restart.
3. Do not repair a defective device. A defective device must only be repaired by the manufacturer.
4. Replace a defective device only by a device of the same type.

## 7 List of Abbreviations

<b>ESD</b>	<b>Emergency Shutdown</b>
<b>FIT</b>	<b>Failure In Time</b> in $10^{-9}$ 1/h
<b>FMEDA</b>	<b>Failure Mode, Effects, and Diagnostics Analysis</b>
$\lambda_s$	Probability of safe failure
$\lambda_{dd}$	Probability of dangerous detected failure
$\lambda_{du}$	Probability of dangerous undetected failure
$\lambda_{no\ effect}$	Probability of failures of components in the safety loop that have no effect on the safety function. The no effect failure is not used for calculation of SFF.
$\lambda_{not\ part}$	Probability of failure of components that are not in the safety loop
$\lambda_{total\ (safety\ function)}$	Safety function
<b>HFT</b>	<b>Hardware Fault Tolerance</b>
<b>MTBF</b>	<b>Mean Time Between Failures</b>
<b>MTTR</b>	<b>Mean Time To Restoration</b>
<b>PCS</b>	<b>Process Control System</b>
<b>PFD<sub>avg</sub></b>	<b>Average Probability of dangerous Failure on Demand</b>
<b>PFH</b>	<b>Average frequency of dangerous failure</b>
<b>PTC</b>	<b>Proof Test Coverage</b>
<b>SFF</b>	<b>Safe Failure Fraction</b>
<b>SIF</b>	<b>Safety Instrumented Function</b>
<b>SIL</b>	<b>Safety Integrity Level</b>
<b>SIL (SC)</b>	<b>Safety Integrity Level (Systematic Capability)</b>
<b>SIS</b>	<b>Safety Instrumented System</b>
<b>T<sub>1</sub></b>	<b>Proof Test Interval</b>

# PROCESS AUTOMATION – PROTECTING YOUR PROCESS



## Worldwide Headquarters

Pepperl+Fuchs GmbH  
68307 Mannheim · Germany  
Tel. +49 621 776-0  
E-mail: [info@de.pepperl-fuchs.com](mailto:info@de.pepperl-fuchs.com)

For the Pepperl+Fuchs representative  
closest to you check [www.pepperl-fuchs.com/contact](http://www.pepperl-fuchs.com/contact)

[www.pepperl-fuchs.com](http://www.pepperl-fuchs.com)

Subject to modifications  
Copyright PEPPERL+FUCHS • Printed in Germany

 **PEPPERL+FUCHS**  
*PROTECTING YOUR PROCESS*

DOCT-5291  
06/2016