

SmartRunner Matcher*

Light section sensor for
high-precision profile
comparison

Manual



With regard to the supply of products, the current issue of the following document is applicable:
The General Terms of Delivery for Products and Services of the Electrical Industry, published
by the Central Association of the Electrical Industry (Zentralverband Elektrotechnik und Elek-
troindustrie (ZVEI) e.V.) in its most recent version as well as the supplementary clause:
"Expanded reservation of proprietorship"

Worldwide

Pepperl+Fuchs Group
Lilienthalstr. 200
68307 Mannheim
Germany
Phone: +49 621 776 - 0
E-mail: info@de.pepperl-fuchs.com

North American Headquarters

Pepperl+Fuchs Inc.
1600 Enterprise Parkway
Twinsburg, Ohio 44087
USA
Phone: +1 330 425-3555
E-mail: sales@us.pepperl-fuchs.com

Asia Headquarters

Pepperl+Fuchs Pte. Ltd.
P+F Building
18 Ayer Rajah Crescent
Singapore 139942
Phone: +65 6779-9091
E-mail: sales@sg.pepperl-fuchs.com
<https://www.pepperl-fuchs.com>

1	Introduction.....	5
1.1	Content of this Document.....	5
1.2	Target Group, Personnel	5
1.3	Symbols Used	6
2	Product Specifications.....	7
2.1	Use and Application	7
2.2	Hazards of Laser Radiation	10
2.3	Dimensions.....	11
2.4	Displays and Controls	12
2.5	Interfaces.....	14
2.6	Accessories.....	14
3	Installation.....	15
3.1	Storage and Disposal.....	15
3.2	Preparation	15
3.3	Mounting the Sensor	16
3.4	Electrical Connection	18
3.5	Detection range.....	22
4	Commissioning.....	23
4.1	Connecting the Sensor	23
5	Vision Configurator Software	24
5.1	Connecting to Vision Configurator	25
5.2	Application Window Structure.....	27
5.3	Menu Bar.....	29
5.3.1	File Menu.....	29
5.3.2	View Menu.....	29
5.3.3	Sensor Menu	30
5.3.4	Image Menu.....	31
5.3.5	Administration Menu	31
5.3.6	Help Menu	32
5.4	Toolbar	33
5.5	Sensor Data	34
5.6	Image Display.....	35

5.7	Configuration window	40
5.7.1	Sensor Information.....	40
5.7.2	Common Tab.....	41
5.7.3	Matcher Tab	43
6	Operation	49
6.1	Configuration Mode	49
6.2	Code Card Mode	55
6.2.1	Setting Device Parameters via Control Code	56
6.3	Presentation Mode.....	57
6.4	Runtime Mode	58
6.4.1	Communication via the RS-485 Interface.....	58
7	Maintenance and Repair	63
7.1	Servicing.....	63
7.2	Repair	63
8	Troubleshooting	64
8.1	What to Do in Case of a Fault.....	64
9	License Note.....	65
10	Appendix.....	66
10.1	Code Cards for Profile Changing	66

1 Introduction

1.1 Content of this Document

This document contains information required to use the product in the relevant phases of the product life cycle. This may include information on the following:

- Product identification
- Delivery, transport, and storage
- Mounting and installation
- Commissioning and operation
- Maintenance and repair
- Troubleshooting
- Dismounting
- Disposal



Note

For full information on the product, refer to the further documentation on the Internet at www.pepperl-fuchs.com.

The documentation comprises the following parts:

- This document
- Datasheet

In addition, the documentation may comprise the following parts, if applicable:

- EU-type examination certificate
- EU declaration of conformity
- Attestation of conformity
- Certificates
- Control drawings
- Instruction manual
- Other documents

1.2 Target Group, Personnel

Responsibility for planning, assembly, commissioning, operation, maintenance, and dismantling lies with the plant operator.

Only appropriately trained and qualified personnel may carry out mounting, installation, commissioning, operation, maintenance, and dismantling of the product. The personnel must have read and understood the instruction manual and the further documentation.

Prior to using the product make yourself familiar with it. Read the document carefully.

1.3 Symbols Used

This document contains symbols for the identification of warning messages and of informative messages.

Warning Messages

You will find warning messages, whenever dangers may arise from your actions. It is mandatory that you observe these warning messages for your personal safety and in order to avoid property damage.

Depending on the risk level, the warning messages are displayed in descending order as follows:



Danger!

This symbol indicates an imminent danger.

Non-observance will result in personal injury or death.



Warning!

This symbol indicates a possible fault or danger.

Non-observance may cause personal injury or serious property damage.



Caution!

This symbol indicates a possible fault.

Non-observance could interrupt the device and any connected systems and plants, or result in their complete failure.

Informative Symbols



Note

This symbol brings important information to your attention.



Action

This symbol indicates a paragraph with instructions. You are prompted to perform an action or a sequence of actions.

2 Product Specifications

2.1 Use and Application

This manual applies to the light section sensors SmartRunner Matcher (hereafter referred to as sensor). The sensor compares current height profiles with a previously taught-in height profile. The sensor is based on SmartRunner technology and combines the light section method for detecting height profiles with a 2-D vision sensor.

An emitter optic is used to project a laser line onto an object as part of the light section method. This is detected by a camera at a specific angle. A height and width profile is created using the triangulation principle. This laser technology provides reliable measurements on different surfaces.

The sensor is commissioned and operated using the Vision Configurator software. In addition, preset parameters can be transferred to the sensor via Data Matrix control codes. In this way you have the opportunity to quickly adapt the settings to the conditions of the measuring environment and the measuring object without using a laptop in case of replacement.

Structure of the sensor

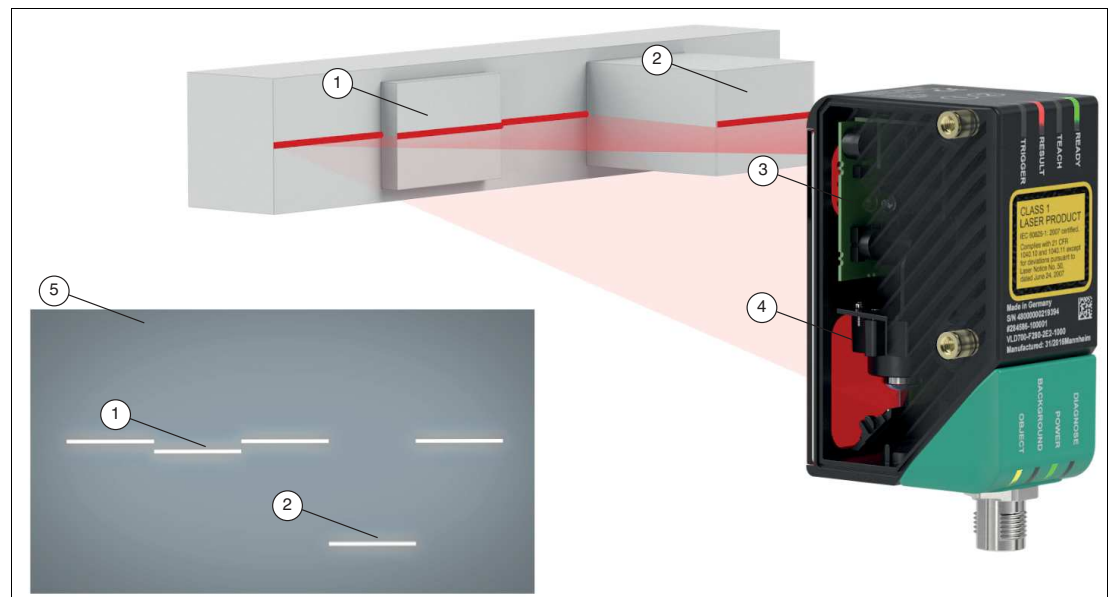

Figure 2.1 Overview of components and measurement result

- 1 Flat profile
- 2 Raised profile
- 3 Emitter optic (vision sensor including LED lighting)
- 4 Camera
- 5 Height profile on the image sensor (measuring result)

The SmartRunner has an optimized hardware and software platform. It is available in different versions for specific applications. The device is certified according to laser protection class 1.

Features of the sensor

The sensor, optimized and pre-configured for comparing height profiles, offers protection from damage and from the production of rejects. An object is identified by comparing with stored reference profiles, which detects whether the object is in the correct position. This means gripping processes, such as in robotics, are always accurate.

The integrated control interface of the sensor has been optimized by the factory to report deviations from a previously programmed contour. Via the profile comparison, the sensor detects the recorded contour of an object, its correct location, and spacing. In case of a fault, collisions and damage are safely eliminated and lengthy machine downtimes are therefore avoided.

For this, the sensor is taught in to a specific height profile and a trigger executes a reconciliation between the currently-recorded contour and the reference contour. A "good" signal is produced if these are identical. If the two profiles differ, a "Bad" signal is produced.

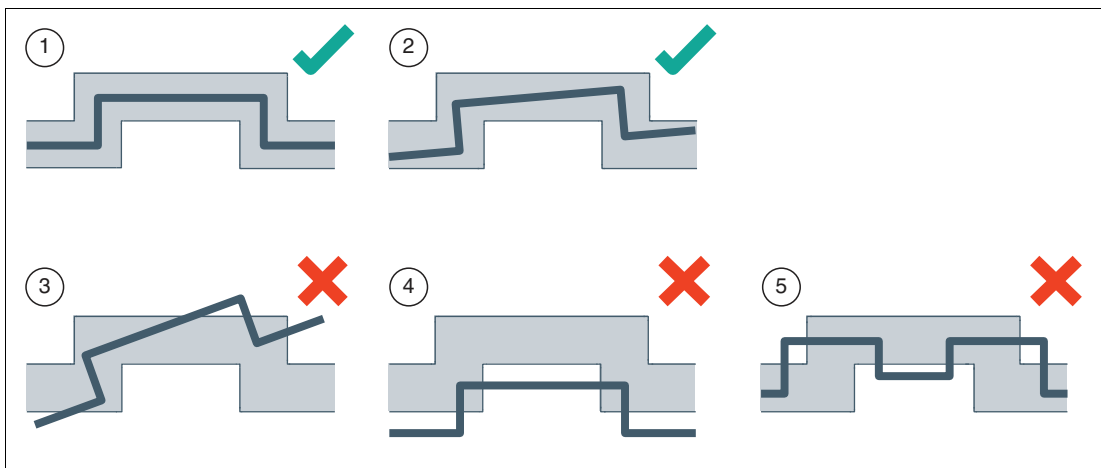

Figure 2.2 Capturing object contour, position, and distance

Position	Designation	Function
1	Good-signal-scenario 1	Taught-in reference contour with adjustable tolerance range
2	Good-signal-scenario 2	Slight torsion within the tolerance range
3	Bad-signal-scenario 3	Excessive torsion outside the tolerance range
4	Bad-signal-scenario 4	Too great a distance between sensor and object
5	Bad-signal-scenario 5	Incorrect or faulty object detected

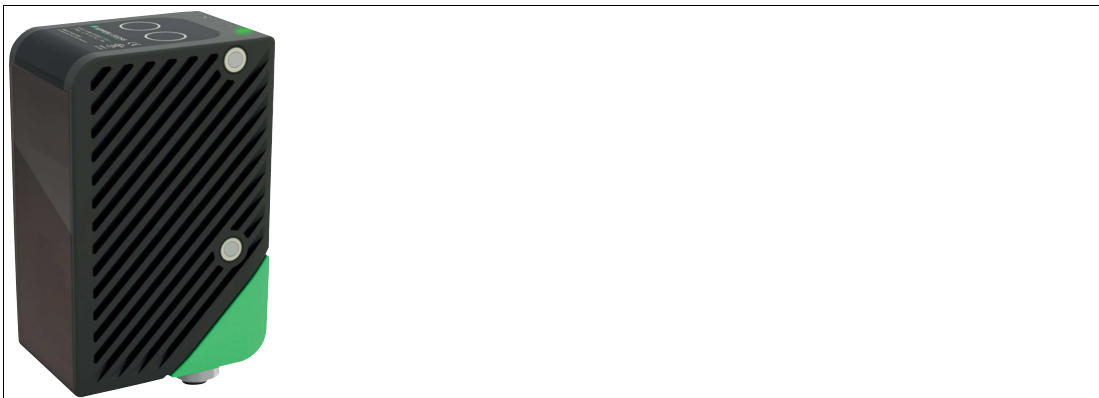

Figure 2.3 Sensor

Parameterization and Operating Modes

The laser-line triangulation sensor can be configured or parameterized via 3 different methods.

- Reading in code cards via the sensor camera
- Processing configuration telegrams via the bus interface
- Using the Vision Configurator software

The sensor has different operating modes, which can be activated for configuration, presentation, or normal operation.

- Runtime mode: measurement mode, sensor works as configured
- Configuration mode: mode for configuring the sensor via data telegrams and via the Vision Configurator configuration program
- Code card mode: mode for configuring the sensor via Data Matrix control codes without the assistance of a PC
- Presentation mode: mode for presentation or testing without the assistance of a PC

2.2 Hazards of Laser Radiation

This section describes the contents and location of the warning label.

The sensor used corresponds to the safety standard IEC 60825-1:2007 for a laser class 1 product. In addition, the US regulation 21 CFR 1040.10 and 1040.11 is fulfilled except for **Laser Notice No. 50** dated June 24, 2007.



Warning!

Class 1 laser light

The laser light can be an irritant, especially in a dark environment. Do not point lasers at people!

Never look into the laser beam port if the sensor is operating.

Maintenance and repairs must be carried out by authorized service personnel only!

Install the device so that the warning is clearly visible and legible.

Do not remove the sensor's protective cover.

The warning label is fixed to the back of the housing as shown in the following figure.

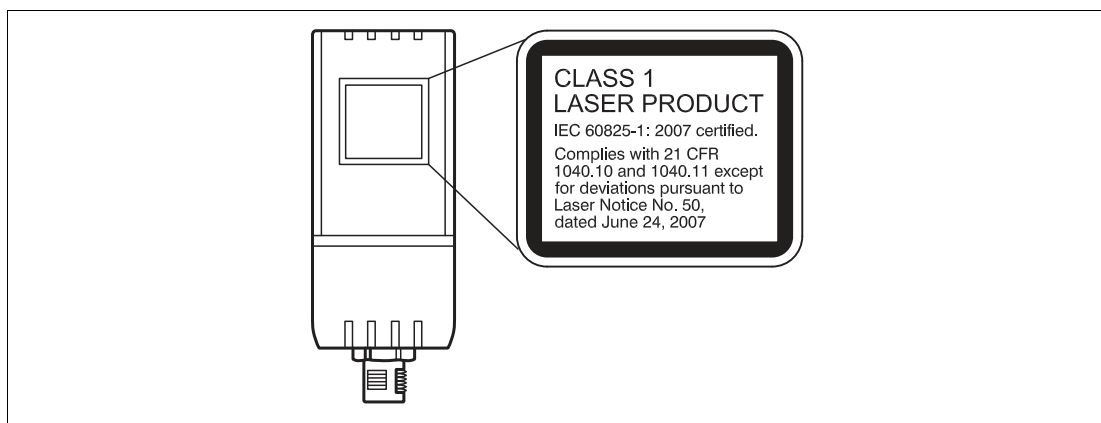

Figure 2.4 Laser radiation warning message

2.3 Dimensions

The devices in the SmartRunner series have the following identical housing dimensions.

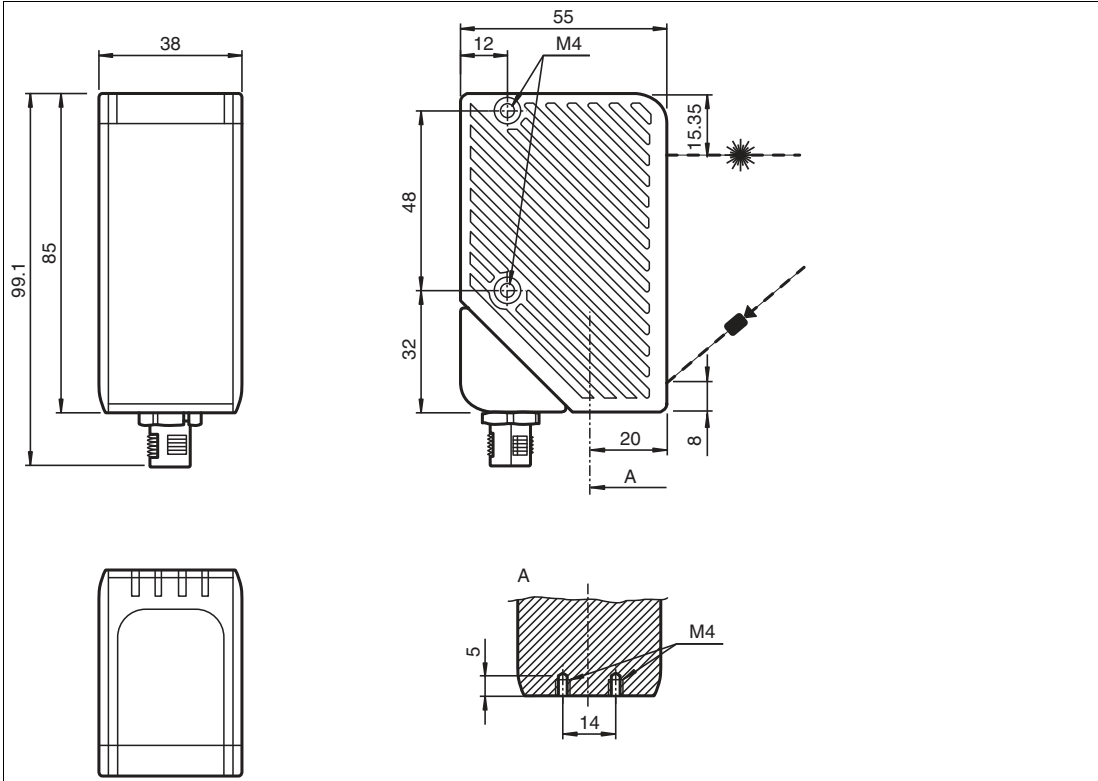

Figure 2.5 Dimensions of the SmartRunner series

2.4 Displays and Controls

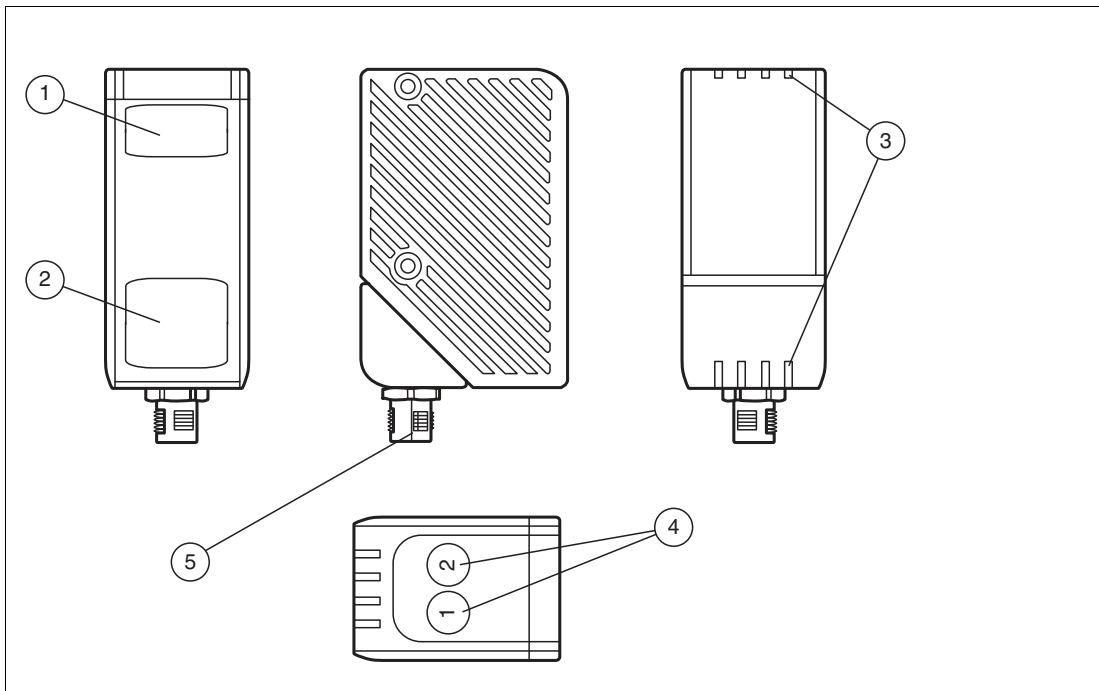

Figure 2.6 Overview of displays and controls

Position	Designation	Function
1	Emitter optic protective cover	Is used to protect against damage and contamination
2	Reception optic protective cover	Is used to protect against damage and contamination
3	LEDs	The functional description for the LEDs can be found in the table below.
4	Function keys in Presentation mode	<ul style="list-style-type: none"> Function key 1: triggers an evaluation Function key 2: when pressed and held for 2 seconds, activates the teach-in process. When pressed and held for longer than 2 seconds, activates Code Card mode
	Function keys in Runtime mode	<ul style="list-style-type: none"> Function key 1: no function Function key 2: when pressed and held for longer than 2 seconds, activates Code Card mode
5	Electrical Connection	The sensor is connected electrically via a MAIN 8-pin M12 connector plug on the bottom of the housing. See chapter 3.4.

Note

The function keys are only activated during a parameterizable time span after the sensor is switched on, after which they are locked. The default value for this time span is 5 minutes.

The function keys have different functions depending on the selected operating state.



Description of the LEDs

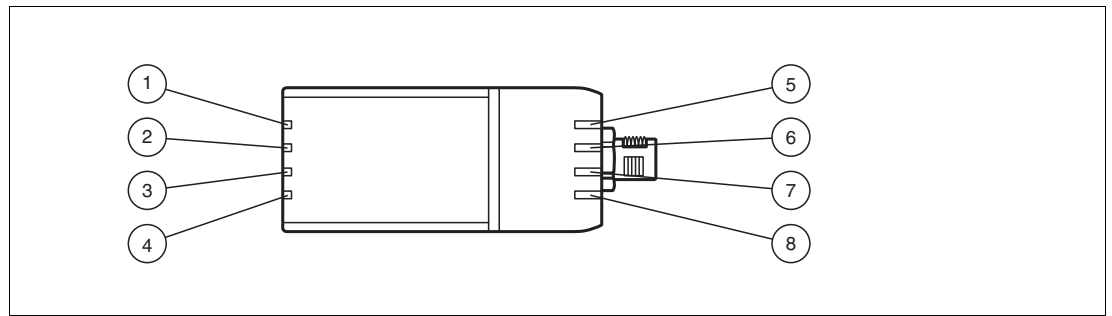

Figure 2.7 LEDs overview

Position	Designation	Function
1	Ready (green/red)	<ul style="list-style-type: none"> Lights up red if there is a sensor fault Lights up green when the sensor is ready for operation Flashes green if the sensor is in Configuration mode
2	Match 3/4 (green/yellow)	<ul style="list-style-type: none"> Lights up green if the scanned profile matches the taught-in profile 3 (MATCH 3) Lights up yellow if the scanned profile matches the taught-in profile 4 (MATCH 4)
3	Result (green/red)	<ul style="list-style-type: none"> Lights up green if a scanned profile matches a taught-in profile Lights up red if a scanned profile does not match a taught-in profile
	Applies in Code Card mode	<ul style="list-style-type: none"> Lights up green when a correct code has been read Lights up red when an incorrect code has been read Off if no code has been read
4	Match 1/2 (green/yellow)	<ul style="list-style-type: none"> Lights up green if the scanned profile matches the taught-in profile 1 (MATCH 1) Lights up yellow if the scanned profile matches the taught-in profile 2 (MATCH 2), optional
5	Diagnosis (red)	<ul style="list-style-type: none"> Lights up red if a bus error has occurred Lights up red if a system error has occurred on the interface controller Flashes red if the sensor is in Update mode
6	POWER (green)	<ul style="list-style-type: none"> Lights up as soon as voltage is present Flashes in Configuration mode
7	Teach in (yellow)	<ul style="list-style-type: none"> Lights up yellow during the teach in process
8	TRIGGER (yellow)	<ul style="list-style-type: none"> Lights up yellow if the hardware trigger signal is activated

2.5 Interfaces

The RS-485 Interface

The reader is equipped with an RS-485 interface for communication purposes, i.e., parameterizing the reader functions or reading out current process data during operation. This interface is operated in 8-E-1 operating mode and fitted with a terminator that can be activated or deactivated by parameterizing the sensor head.

The RS-485 interface supports the following transfer rates:

- 9600 Bit/s
- 14400 Bit/s
- 19200 Bit/s
- 28800 Bit/s
- 38400 Bit/s
- 57600 Bit/s
- 76800 Bit/s
- **115200 Bit/s** (default value)
- 230400 Bit/s

Data structure of the RS-485 interface

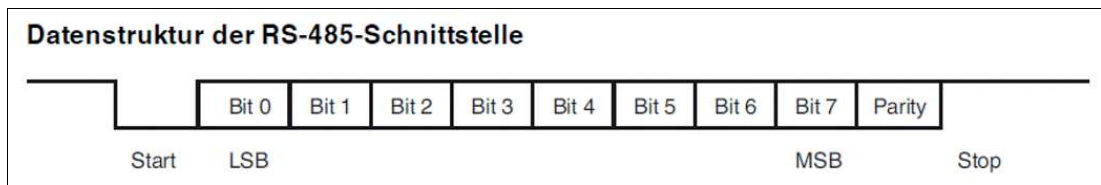

2.6 Accessories

Order designation	Description
V19-G-5M-PUR-ABG	Single-ended female cordset, M12, 8-pin, shielded, PUR cable
VLX-MB1	Mounting aid, adaptable 360° adjustment of mounting head and mounting foot
VLX-MB2	Mounting aid, fixing bracket
PCV-USB-RS485 Converter Set	USB to RS 485 interface converter

Other accessories can be found online at www.pepperl-fuchs.com.

3 Installation

3.1 Storage and Disposal

Keep the original packaging. Always store and transport the device in the original packaging.

Store the device in a clean and dry environment. The permitted ambient conditions must be considered, see datasheet.

The device, built-in components, packaging, and any batteries contained within must be disposed in compliance with the applicable laws and guidelines of the respective country.

3.2 Preparation



Unpacking the Device

1. Check the packaging and contents for damage.
↳ In the event of damage, inform the shipping company and notify the supplier.
2. Check the package contents against your order and the shipping documents to ensure that all items are present and correct.
↳ Should you have any questions, direct them to Pepperl+Fuchs.
3. Retain the original packaging in case the device is to be stored or shipped again at a later date.

3.3 Mounting the Sensor



Note

Mounting an optical device

- Do not aim the sensor at the sun.
- Protect the sensor from direct long-term exposure to sun.
- Prevent condensation from forming by not exposing the sensor to any major fluctuations in temperature.
- Do not expose the sensor to the effects of any aggressive chemicals.
- Keep the lenses and reflector of the device clean. Clean with a soft cloth, using standard commercial glass cleaner if necessary.

We recommend to clean the optical surface and to check screw fittings and electrical connections at regular intervals.

The operating distance differs depending on the sensor. The correct operating distance can be found in the datasheet for the sensor to be installed.

The following two figures show the orientation of the sensor under extraneous light:

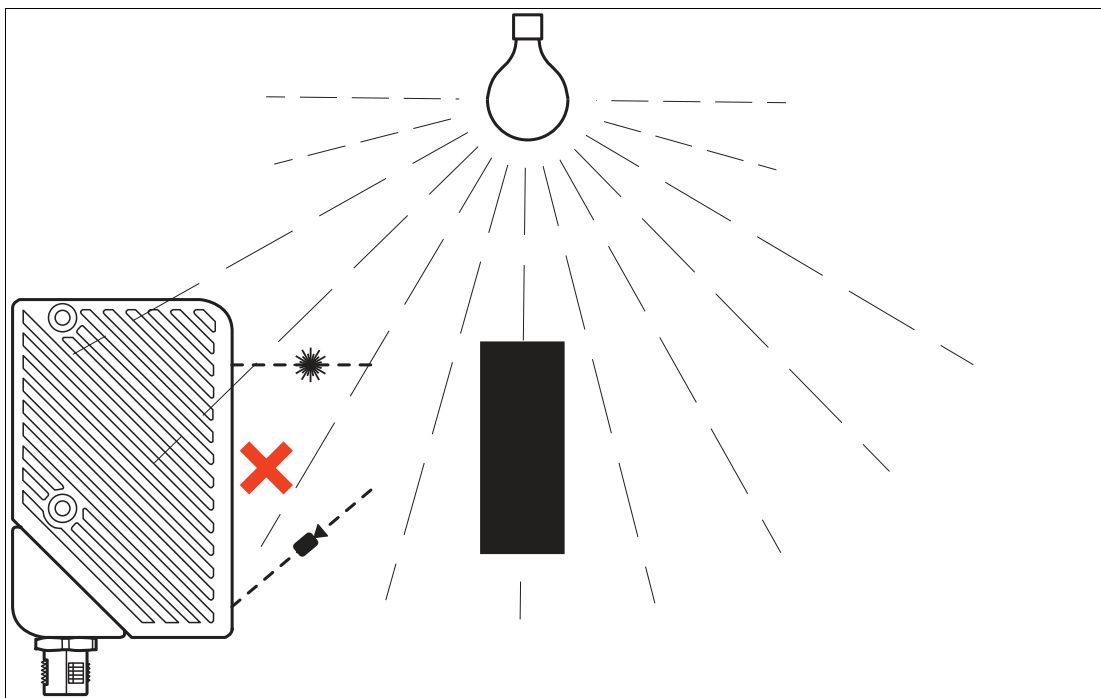

Figure 3.1 Incorrect orientation

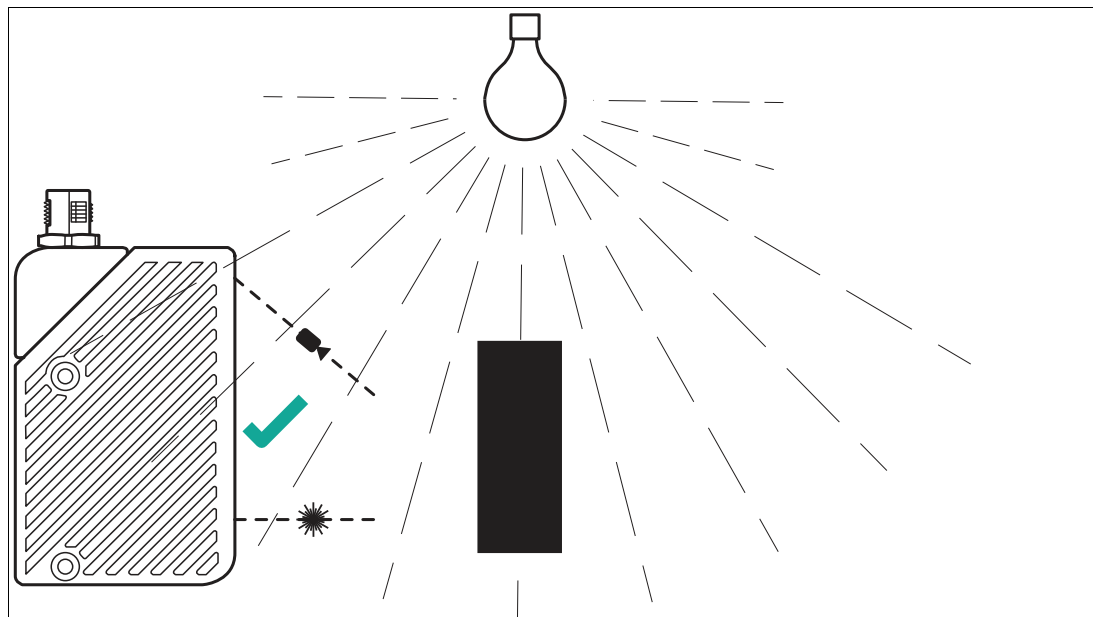

Figure 3.2 Correct orientation

The surface must be level to prevent the housing from becoming misaligned when the fittings are tightened. We advise securing the screws with spring disks to prevent the sensor becoming misaligned. Following installation of the sensor, ensure that there is still sufficient space to connect the connection cable to the sensor



Caution!

Damage to the equipment caused by improper installation!

Device components can be damaged if the permissible screw-in depths and the maximum permissible tightening torque is exceeded.

Note that the threads on the bottom of the housing are not thru-holes.

Observe the maximum permissible screw-in depth to avoid damaging the device or mounting incorrectly.

Never exceed the maximum permissible tightening speed of the fixing screws. The maximum tightening torque of the mounting screws must not exceed 2 Nm.

Mounting the Housing

The device has 2 M4 threads on the base and on both sides of the housing to allow easy installation of the sensor in your plant. This means there are 3 different ways to mount the sensor in your plant.

- One-sided lateral mounting with M4 screws: You can mount the housing on its right-hand or left-hand side using the 2 M4 threaded sleeves. The maximum screw-in depth of the M4 screws is 8 mm.
- Continuous lateral mounting with M3 screws: M4 threaded sleeves are designed in such a manner that M3 screws pass all the way through the housing. Use 2 sufficiently long M3 screws with 2 lock nuts to mount the device in the plant
- Mounting on the underside of the device with M4 screws: You can use the 2 threaded sleeves to mount the housing on the underside of the device. The maximum screw-in depth of the M4 screws is 5 mm.

Positioning the Sensor

When positioning the sensor, ensure that the camera's field of vision is not obscured by the objects being scanned.

3.4 Electrical Connection



Connecting the Supply Voltage

The sensor is connected electrically via a **MAIN** 8-pin M12 connector plug on the bottom of the housing. The power supply and data transfer take place via this connection. To connect the sensor, proceed as follows:

1. Plug the 8-pin M12 socket into the plug on the bottom of the housing.
2. Screw the lock nut onto the connector as far as it will go. This ensures that the power cable cannot be pulled out inadvertently.



Tip

The corner of the housing where the **MAIN** 8-pin M12 connector plug is located can be rotated. Depending on the mounting position, you can rotate the connector plug in a different direction to ensure simple cabling.

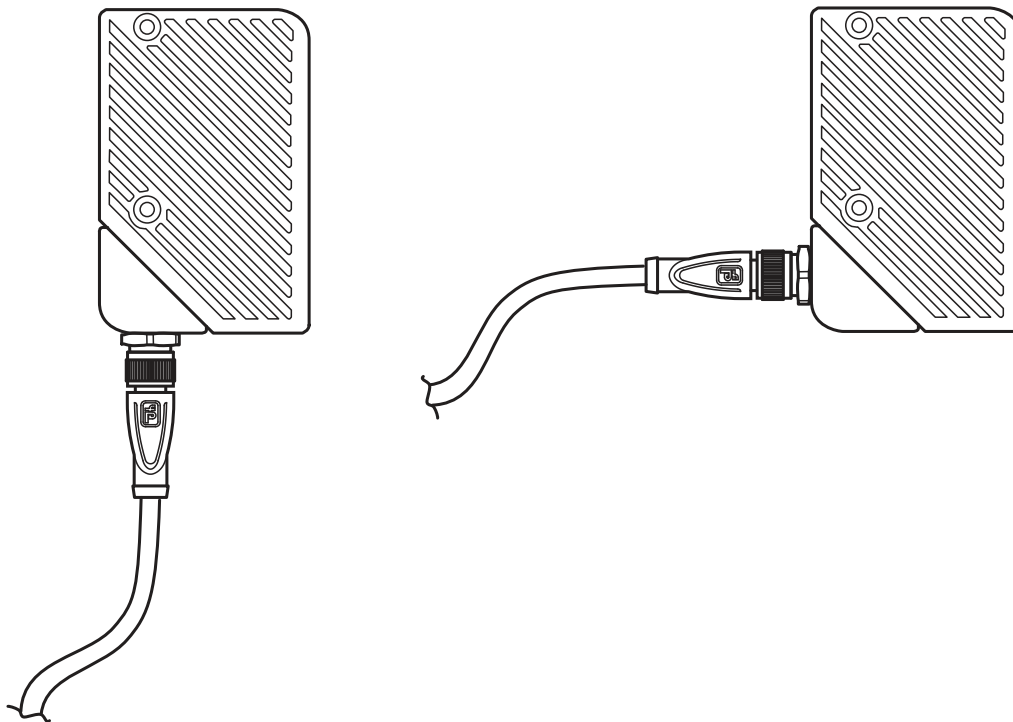

Figure 3.3 M12 connector plug

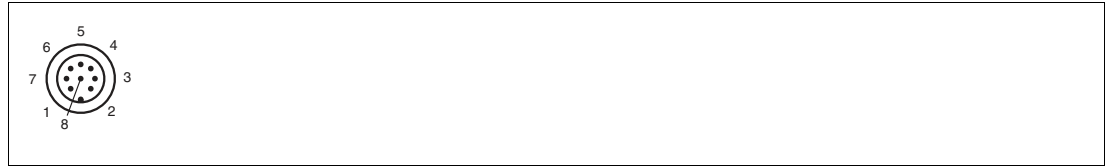

Figure 3.4 Connection layout

Pepperl+Fuchs single-ended female cordsets are manufactured in accordance with EN60947-5-2. When using a V19-G-5M-PUR-ABG single-ended female cordset with an open cable end, connector pins are assigned as follows:

Pin	Wire color	Signal	Description
1	white	IN trigger	Trigger input. Triggers an evaluation, if the sensor is in continuous evaluation mode (independent)
2	brown	+UB	+ 24 V power supply
3	green	Data+ RS-485	RS-485 interface: Data +
4	yellow	Data- RS-485	RS-485 interface: Data -
5	gray	Teach	Control signal for teaching in the background line
6	pink	Good	Output 1 is set if the height profile detected matches the taught-in profile in terms of form and position. Once the teach-in process has been performed, this output signals that teach-in was successful
7	blue	GND	Ground for the + 24 V power supply
8	red	Bad	Output 2 is set if: <ul style="list-style-type: none"> • No object has been detected or <ul style="list-style-type: none"> • The form detected does not match the taught-in form or <ul style="list-style-type: none"> • The position detected is outside the tolerance. Once the teach-in process has been performed, this output signals that teach-in has not been successful



Connection using the RS-485 Interface

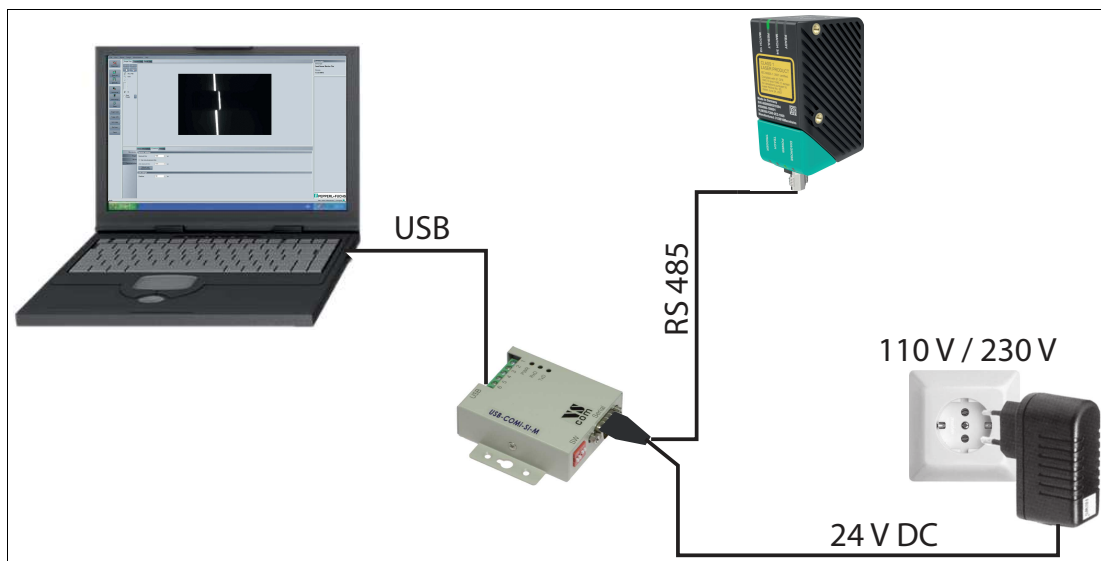

Figure 3.5 PCV-USB-RS-485 Converter Set

1. Plug a plug-in power supply into a socket and connect it to the interface converter.
↳ The indicator LEDs on the sensor light up.
2. Establish a USB connection between the PC system and interface converter.
↳ The PWR LED on the interface converter lights up red.



Caution!

Damage to the device

Connecting an alternating current or excessive supply voltage can damage the device or cause the device to malfunction.

Electrical connections with reversed polarity can damage the device or cause the device to malfunction.

Connect the device to direct current (DC). Ensure that the supply voltage rating is within the specified device range. Ensure that the connecting wires on the female cordset are connected correctly.

Shielding Cables

The shielding of connection lines is required to suppress electromagnetic interference. Establishing a low resistance or low impedance connection with the protective conductor or equipotential bonding circuit is a particularly important factor in ensuring that these interference currents do not become a source of interference themselves. Only use connection lines with braid. Avoid connection lines with foil shield because this would increase the line capacities. The shielding is integrated at both ends, i.e., in the switch cabinet or on the PLC, **and** on the read head. The grounding terminal available as an accessory allows easy integration in the equipotential bonding circuit.

In exceptional cases, the shielding of a connection at one end may be more favorable if:

- An equipotential bonding cable is not laid or cannot be laid.
- A film shield is used.

The following points relating to shielding must be noted:

- Use metal cable clips that cover large areas of the shielding.
- Place the cable shield onto the equipotential bonding rail immediately on entering the switch cabinet.
- Direct the protective grounding connections to a common point in a star configuration.
- The cross-section of the cables used for grounding should be as large as possible.

Additional Ground Connection

Order designation	Description
PCV-SC12	Clip for mounting an additional ground connection.
PCV-SC12A	

3.5 Detection range

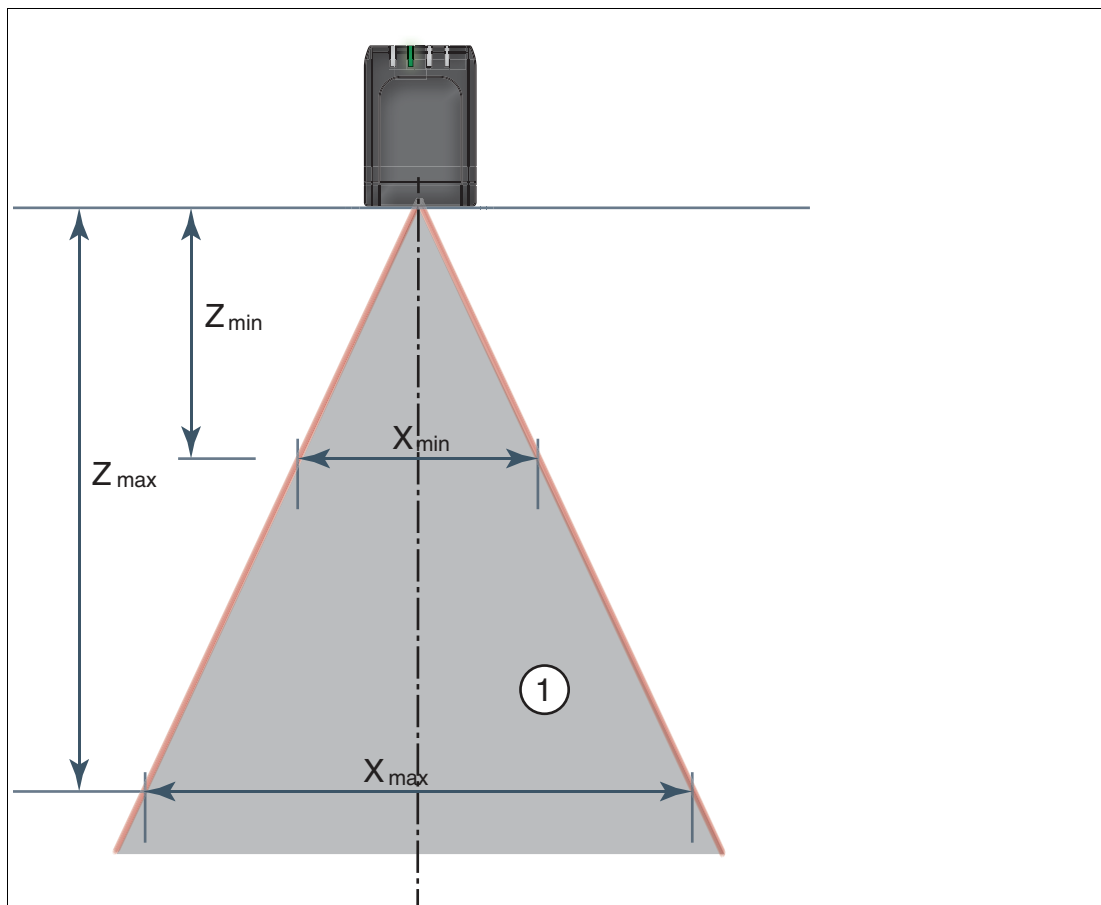

Figure 3.6 Detection range

1 Field of view

Note the detection range of the SmartRunner Matcher when planning your plant. You will find more information on the detection range in the respective data sheet of the sensor.



Note

The smallest possible resolution in the X and Z direction increases on a linear basis to the distance Z to the sensor.

4 Commissioning

4.1 Connecting the Sensor

The sensor is configured using the Vision Configurator software. You have the opportunity to carry out settings on the sensor directly using the Vision Configurator software.



Aligning the Sensor

Use the image display and diagram display in the Vision Configurator software to optimally align the sensor.

1. Power the reader via the 24 VDC socket on the device.
2. Use the automatic exposure time control to set an appropriate exposure value.
 - ↳ If exposure time control was successful, the result LED will light up green.
3. Align the sensor so that a complete line that is as narrow as possible can be seen in the image display.
 - ↳ The optimal reading distance between the sensor and the measurement object is set.

5 Vision Configurator Software

The sensor is commissioned and operated using the Vision Configurator software.

The Vision Configurator software makes it easy to operate the sensor with its user-friendly interface. Standard functions include making connections to the sensor, specifying the operating parameters, saving data sets, and displaying data and error diagnostics.



Note

The following user roles are predefined with different authorizations in the Vision Configurator.

User Rights and Password

User rights	Description	Password
Default	View all information Sensor configuration Create users at same or lower level	A password is not required
User	View all information Sensor configuration Create users at same or lower level	User
Admin	View all information Sensor configuration	Request the admin password from Pepperl+Fuchs

Table 5.1 The users have different access and administration rights depending on the respective user role.



Establishing a Network Connection

To establish a network connection with the sensor, proceed as follows:

1. Supply the sensor with power.
2. Start the Vision Configurator software.
3. Enter your user name and password.



Note

Additional steps for user-defined installation and installation of additional components are described in the Vision Configurator manual. The Vision Configurator manual can be found online at www.pepperl-fuchs.com.

5.1 Connecting to Vision Configurator



Connect Vision Configurator

Connect the SmartRunner to a PC.



Note

Use a suitable RS-485/USB connecting cable and an adapter cable to do this:

Function	Order designation
USB interface converter to RS-485 including cable unit with power supply	PCV-USB-RS485-Converter Set
Cable unit with power supply for USB/RS-485 interface converter	PCV-KBL-V19-STR-RS485

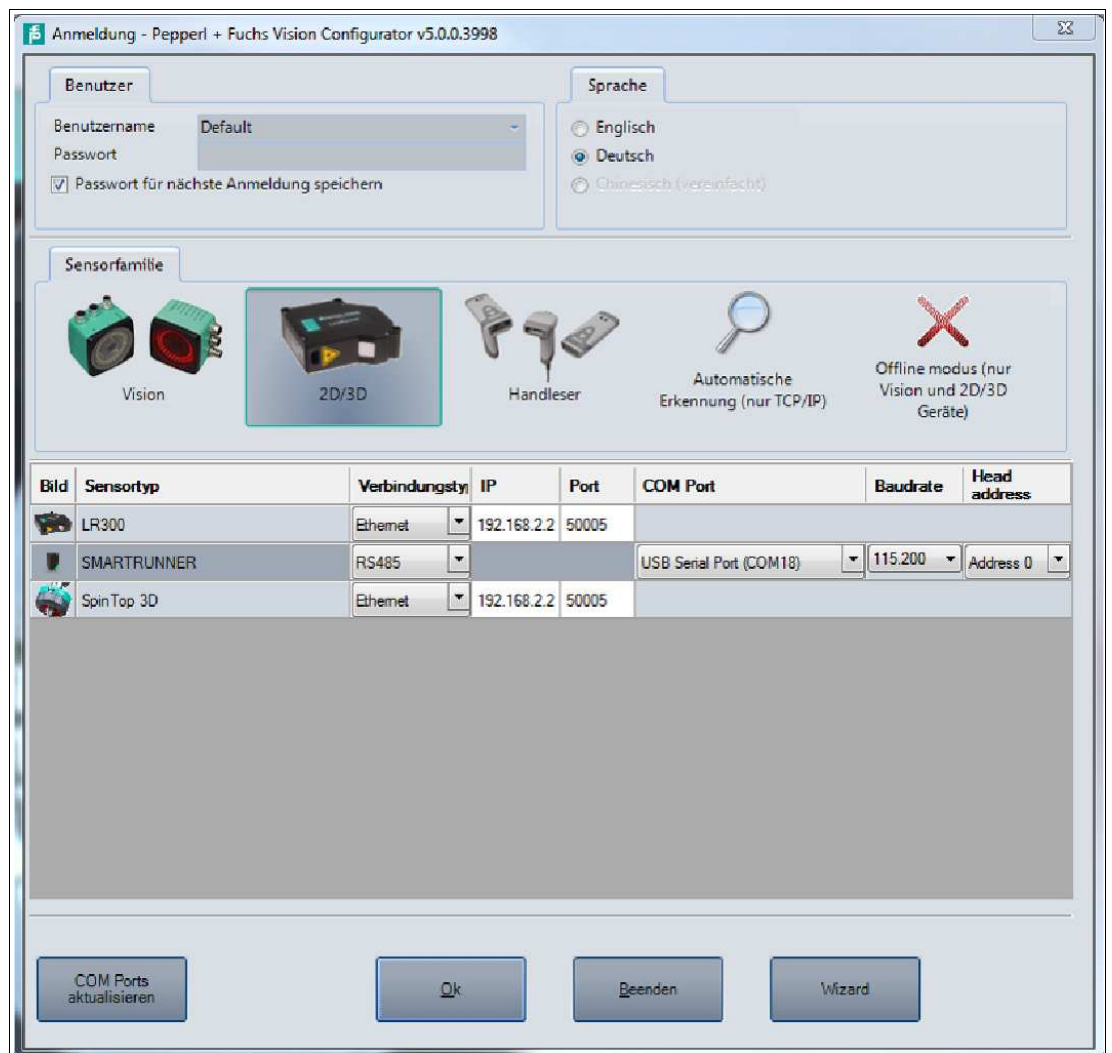

Figure 5.1 Home screen

Wizard - Operation assistant for Vision Configurator

The **Wizard** complements the Vision Configurator configuration software. Double-click on the Wizard button to launch the operation assistant. You will be guided step-by-step through the individual settings.

Proceed as follows to launch the Vision Configurator.



Starting Vision Configurator

1. Select the **2-D/3-D** button on the "Sensor Family" tab.
2. Select **SMARTRUNNER** in the "parameter range" with connection type **RS485**.
3. Select the required **COM port**.
4. In the **Baud rate** window ensure that the value **115,200** is set. Otherwise select the value.
5. In the **Head address** window, ensure that the address is set to **Address 0**. Otherwise select the address.
6. Use the **OK** button to confirm your settings.

↳ The application window will open.

5.2 Application Window Structure

The application screen opens after you log in.



Note

The individual functions depend on the type of sensor connected and the current authorization level, so they are not always all visible.

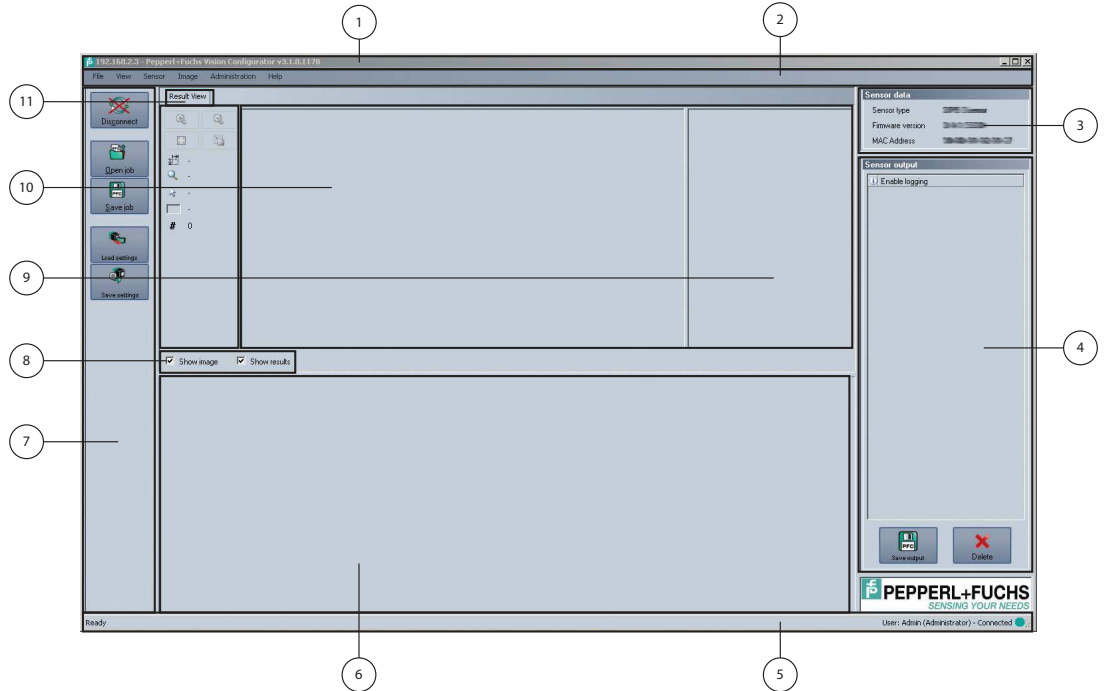

The software is designed to be similar to most Windows applications.

1	Title bar	<ul style="list-style-type: none"> Shows the IP address, the software name, and the version number Contains the Minimize/Maximize/Close buttons
2	Menu bar	<ul style="list-style-type: none"> Displays all the menus in the program Provides an overview and helps with navigation
3	Sensor data screen	<ul style="list-style-type: none"> Displays data for the connected sensor
4	Sensor output screen	<ul style="list-style-type: none"> Shows the log display
5	Status bar	<ul style="list-style-type: none"> Displays status information about the application
6	Configuration window	<ul style="list-style-type: none"> Contains the sensor-specific parameters that you can set
7	Toolbar	<ul style="list-style-type: none"> Contains icon buttons as an extension to the menu
8	Check boxes	<ul style="list-style-type: none"> Show images: Enables or disables the image display Show results: Enables or disables the results area
9	Results area	<ul style="list-style-type: none"> Displays results from the sensor A varying number of tabs can be displayed depending on which sensor is connected This field can be enabled or disabled via Show results

10	Image display	<ul style="list-style-type: none">• Displays the images captured or stored in the error memory• This field can be enabled or disabled via Show images
11	Tab	Displays information about the current image and the pixel under the mouse pointer. The following items are displayed: <ul style="list-style-type: none">• Image size• Zoom level• Mouse position in image coordinates• Current grayscale value• Image number

5.3 Menu Bar

The menu bar contains a list of menu items. The functionality depends on the type of sensor that is connected and the permissions of the user logged in.



Figure 5.2 Menu Bar

5.3.1 File Menu



Figure 5.3 File Menu

Change device	Disconnects the device and returns to the Login dialog.
Open job	Loads a sensor configuration stored on the PC.
Save job	Saves the current sensor configuration on the PC.
Quit	Terminates the program.

Table 5.2 File Menu

5.3.2 View Menu

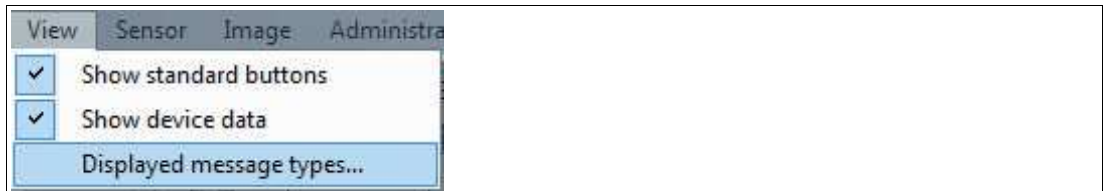

Figure 5.4 View Menu

Show standard buttons	Toggles the display of the buttons in the bar on the left on and off.
Show device data	Hides the display of the sensor data in the top right of the screen.
Displayed message types...	Opens a selection window in which the following display windows can be activated or deactivated: Info, Result OK, Result not OK, Warning, Error, Critical, Assert.

Table 5.3 View menu

5.3.3 Sensor Menu

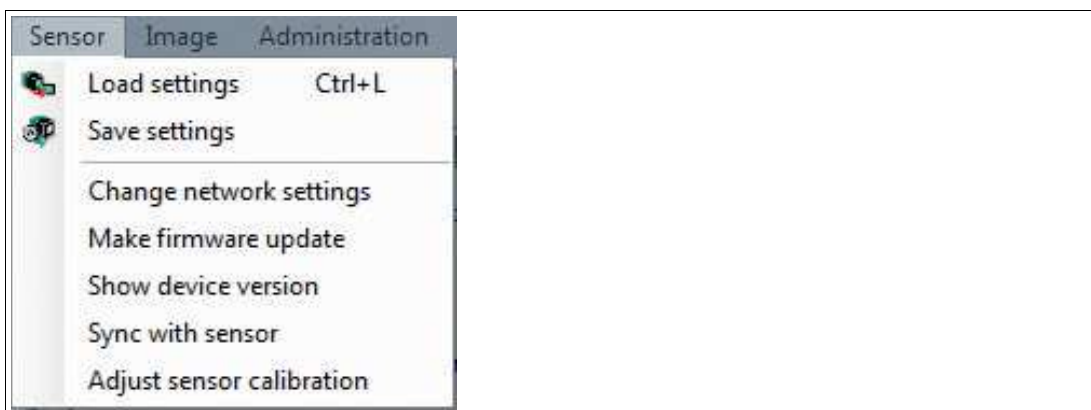

Figure 5.5 Sensor menu

Load settings	Loads the saved settings from the sensor
Save settings	Saves the settings to the sensor
Change network settings	Change the network settings. The settings window allows you to set the IP address, subnet mask, gateway address, and DHCP
Make firmware update	Performs firmware updates. This command should be used by experienced users only
Show device version	Displays the device version
Sync with sensor	Synchronization with the sensor
Adjust sensor calibration	Adjust the sensor calibration

Table 5.4 Sensor menu

Note

Firmware Update

Once you have upgraded the firmware and **Update complete** is displayed, restart the sensor.



5.3.4 Image Menu



Figure 5.6 Image menu

Load imagefile	Loads the image file
Open image folder	Opens the folder in which images are currently saved
Save image	Saves the image currently displayed on the PC
Copy image to clipboard	Loads an image file to the clipboard
Upload image to device	Uploads an image to the device
Show graphic	Switches display data sent from the sensor on and off in the image.

Table 5.5 Image menu

5.3.5 Administration Menu

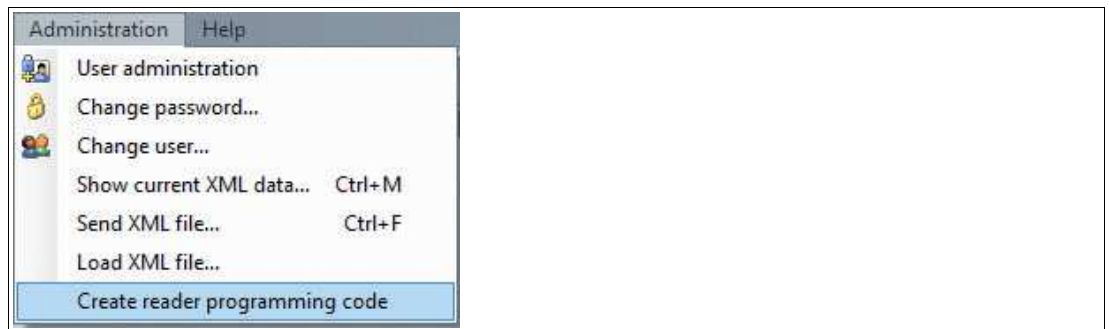

Figure 5.7 Administration menu

User administration	Opens a window that shows all currently created users at the same authorization level or lower. New users at the same authorization level or lower can also be created and deleted here. In addition, a user password can be reset to the default password for the relevant user level.
Change password	Changes the current user's password.
Change user	The login screen opens and a different user and/or sensor can be selected.
Send XML file...	Saves the XML data on a computer.
Load XML file...	Loads XML data from a computer.
Create reader programming code	Creates a reader programming code

Table 5.6 Administration menu

5.3.6 Help Menu

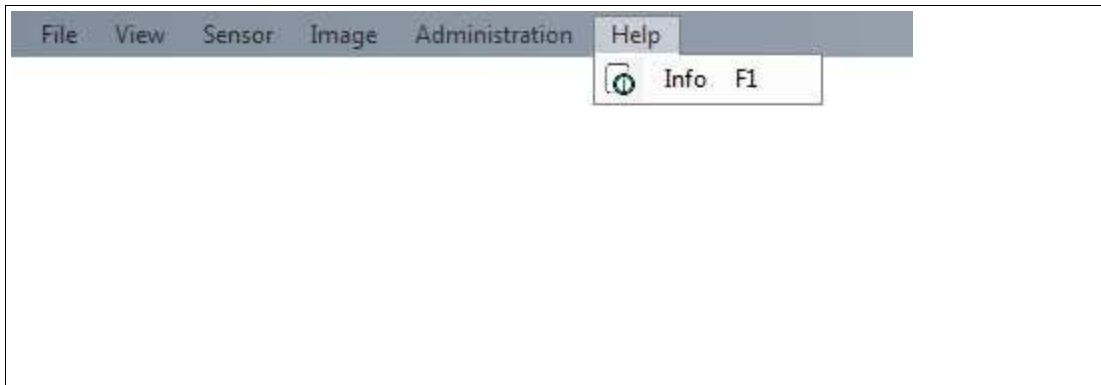









Figure 5.8 Help menu

Info	Displays information about Vision Configurator.
-------------	---

Table 5.7 Help menu

5.4 Toolbar

The toolbar can be used to select various functions.

 Connect	Selecting the Connect button establishes a connection between the PC and the sensor.
 Disconnect	The connection between the PC and the sensor is disconnected.
 Open job	Opens a saved setting.
 Save job	Saves the settings made.
 Load settings	Settings are read out from the sensor.
 Save settings	All settings made are saved on the sensor.
 Reset	Reset to default settings.
Trigger laser	Perform manual trigger.
Trigger LED	Perform LEDs trigger Caution: If autotrigger is activated, a line image will be issued using the "Trigger LED."
Get image	Current sensor image is loaded.
Get lines	The line image is loaded.
Teach	Profile is taught in using the next trigger.

5.5 Sensor Data

This section shows the connected device type and firmware version.

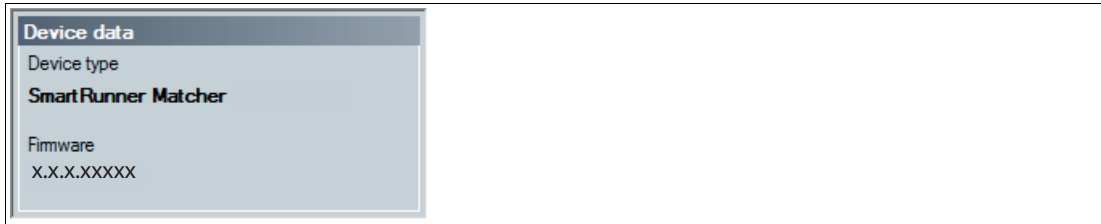

Figure 5.9 Device data

5.6 Image Display

You can evaluate the data recorded in the image display. By analyzing the recorded profile form, it is possible to use the measurement result to make a qualitative assessment. This enables intrusive reflections to be identified and eliminated. There is a relationship between the exposure time and image blur. A correct exposure is dependent on the brightness of the profile and the incident amount of light. An exposure time that is too short leads to underexposed (too dark) images, an exposure time that is too long to overexposed images.

There are various options available to you to display and correct recorded data to avoid errors during recording.

Image View

You can open the currently recorded image under the **Image View** tab. To do this, you must click on the **Teach > Trigger laser > Get image** buttons in the toolbar.



Figure 5.10 Image View

The following context menu appears when you click the right mouse button over the recorded image:

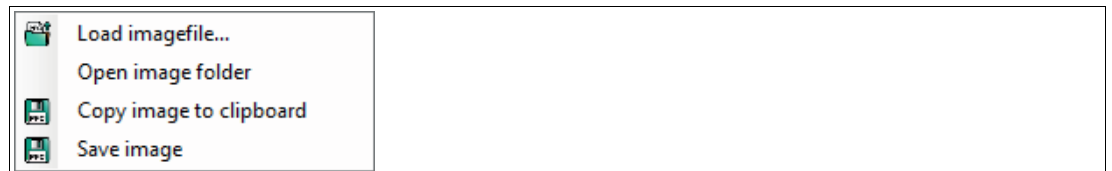

Figure 5.11 Image View context menu screen

Designation	Function
Load image file...	Loads a sensor image. You can select the sensor image.
Open image folder	Opens the storage location
Copy image to clipboard	Copies image to the clipboard
Save image	Saves the displayed sensor image

Image View - Toolbar

The toolbar is located on the left side under the **Image View** tab. There are some useful functions in the toolbar which are used to further process recorded images. The following functions are available to you.

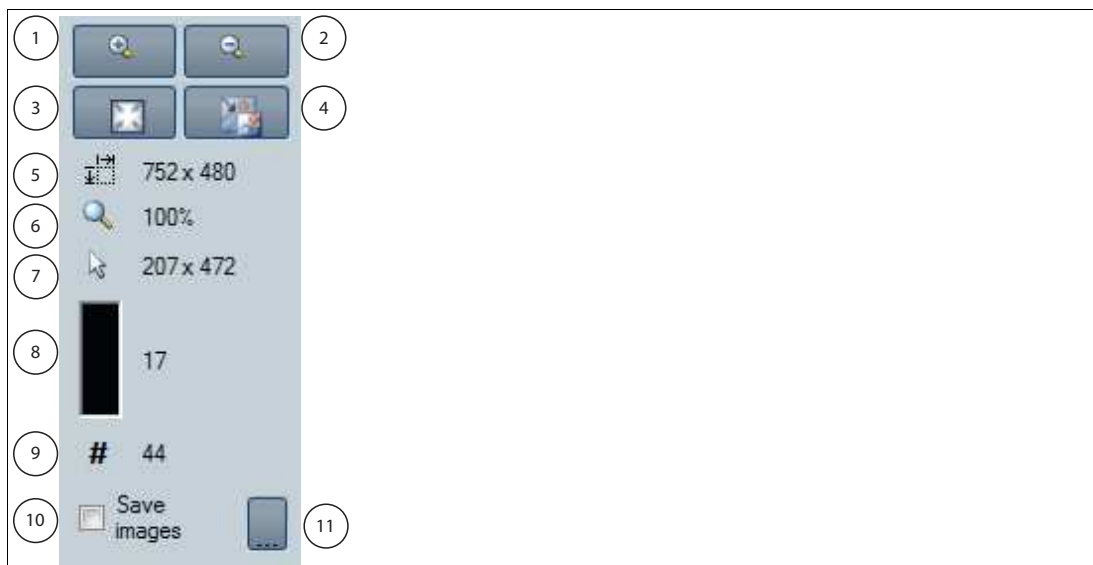

Figure 5.12 Toolbar

Position	Designation	Function
1	Magnifier +	Maximize image
2	Magnifier -	Minimize image
3	Fit to window	Fit image size to the window
4	Original size	Set size of original image
5	Size details	Image size information field
6	Zoom factor	Zoom factor information field. Zoom factor of 100 % is the original image size
7	Position details	Shows the position of the mouse cursor
8	Gray scale value details	Gray scale value details for the pixel indicated by the mouse cursor
9	Image counter	Displays the current image number
10	Save image	Saves image following transfer
11	Select path	Select path on the storage medium

Diagram View

You can open the result data graphic under the **Diagram View** tab. To do this, you must click on the **Teach** > **Trigger laser** > **Get lines** buttons in the toolbar. The graphic can be retrieved using the **Get lines** button. In doing so, the **Get lines** button does not trigger new image captures or evaluation. To do so, **Trigger laser** must be clicked beforehand.

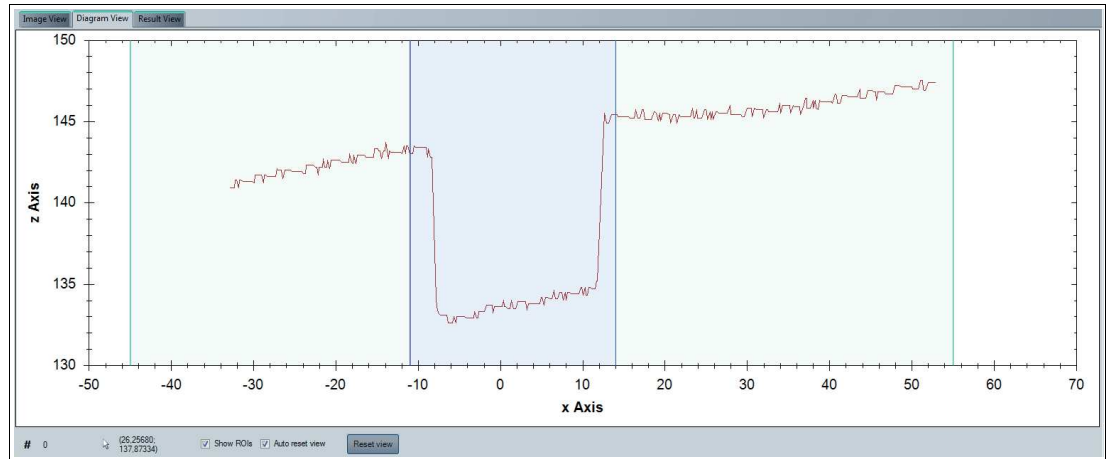

Figure 5.13 Diagram View

The following context menu appears when you click the right mouse button over the graphic:

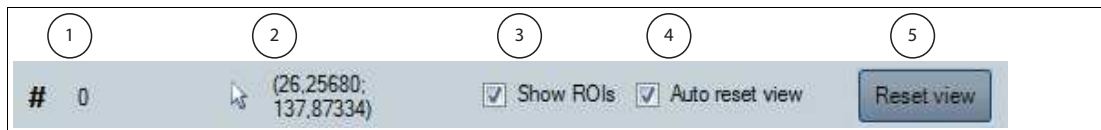

Figure 5.14 Diagram View image display context menu

Designation	Function
Copy	Copies diagram into working memory
Save Image As...	Saves diagram to hard disk
Page Setup...	Page setup for print function
Print...	Print diagram
Show Point Values	Shows the values of the discrete line points in world coordinates [mm] as tooltip.
Un-zoom	Undo the last zoom action
Undo All Zoom/Pan	Undo all the zoom and pan actions
Set Scale to Default	Scales the measure using the line data

Diagram View - Toolbar

The toolbar is located below the diagram view. There are some useful functions in the toolbar which are used to further process the diagrams. The following functions are available to you.



Position	Designation	Function
1	Gray scale value	Gray scale value of the pixel
2	Position details	Shows the position of the mouse cursor in the world coordinate system [mm]
3	Show ROIs	The evaluation range is displayed if the field is selected. The evaluation range is hidden if the field is deactivated.
4	Auto reset view	Automatically jump back to the evaluation range
5	Reset view	Resets to the original view

Result View

With the SmartRunner, a **Quality Good** quality threshold can be entered to distinguish between good and bad parts. A good part is taught in to set the quality threshold and the **Quality Good** value is displayed under the **Result View** tab. To do this, the **Autotrigger** must be activated. The results are output using the **Start request** button. Measuring is stopped by clicking on the **Stop request** button.

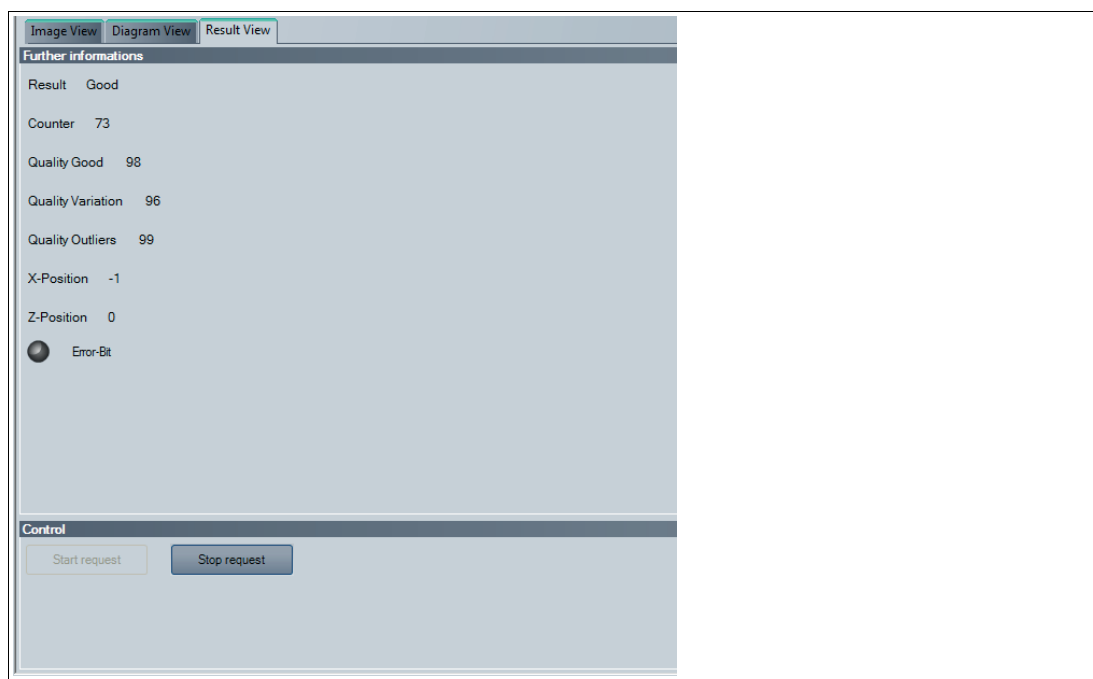

Figure 5.15 Result View

Designation	Function
Result	The sensor automatically gives the Good or Bad output result.
Counter	Counter
Quality Good	Measure of the ratio of the number of pixels in the envelope curve from the taught-in profile to the reference profile.
Quality Variation	A gage for the average deviation of the taught-in profile in the range from 0 % - 100 %, evaluated using the envelope curve. This means that a value of 100 % is produced if the taught-in profile and the reference profile are equal at all points. A value of 0 % is produced if the reference profile for all points is located on the envelope curve or above.
Quality Outliers	Gage for assessing the quality of the curve. The value worsens if parts of the curve are detected as being outside the envelope curve. This means that a value of 100 % is produced if there is no part of the profile outside the envelope curve.
X position	Position of the object in the X direction.
Z position	Position of the object in the Z direction.



Note

Some of the values under the **Result View** tab are password-protected. The access permissions are connected by a password level for each user role. The user rights are defined as follows:

User/Default: Result, Counter, Quality Good, X Position, Z Position

Admin: Result, Counter, Quality Good, Quality Variation, Quality Outliers, X Position, Z Position

5.7 Configuration window

Various parameters are specified in the configuration window. The individual parameters depend on the current authorization level and are, therefore, not always all visible. Some features are available in different variants only. Depending on the parameters set, some fields will be grayed out.

5.7.1 Sensor Information

Sensor Information Tab

Name: "Pepperl+Fuchs GmbH"

Homepage: "http://www.pepperl-fuchs.com/"

Product name: "Smartrunner"

Firmware version: Current firmware version of the main processor.

The version designation as a whole is made up as follows: Major Version.Minor Version.

Tag Number– Revision Number



Figure 5.16 Sensor Information Tab

5.7.2 Common Tab

There are 4 menu items available under the **Common** tab. The purpose of this section is to present the menu items in detail.

Illumination menu item

You can adjust the sensor's exposure under the **Illumination** menu item.

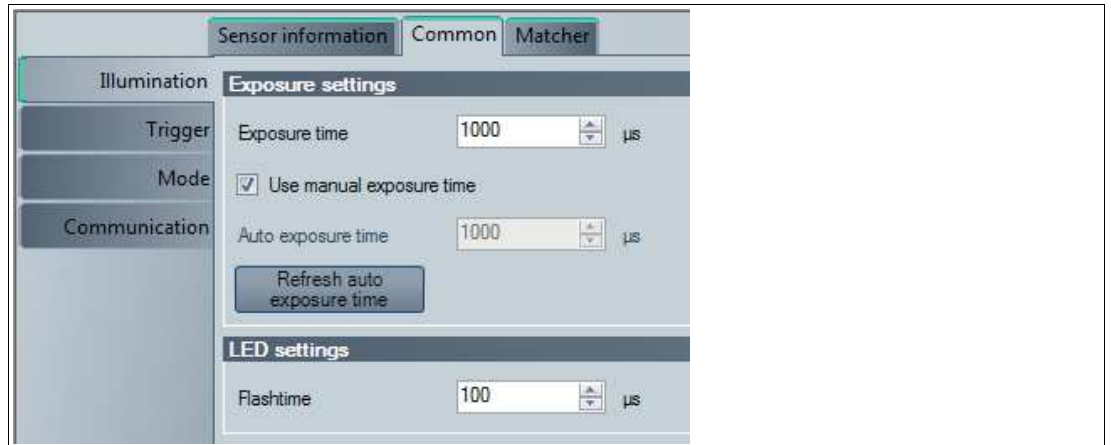

Figure 5.17 Illumination menu item

Designation	Function
Exposure time	Setting the manual exposure time. The "Use manual exposure time" function must be activated to manually adjust the exposure time. By increasing the value, the exposure time and thus the image brightness increase. Values below 1000 µs are suitable in most cases
Use manual exposure time	When enabled, the manually set exposure time is used. If this box is not checked, the exposure time during the teach-in process is controlled automatically
Auto exposure time	The current exposure time is output in this field
Refresh auto exposure time	The "Auto exposure time" field is updated by pressing the button

Trigger menu item

You can enable or disable the autotrigger under the **Trigger** menu item.



Figure 5.18 Trigger menu item

Designation	Function
Autotrigger	The autotrigger must be activated in "Presentation mode." The autotrigger must be activated to adjust the "quality threshold."

Mode menu item

You can enable or disable "Presentation mode" and "function keys 1 and 2" under the **Mode** menu item. "Presentation mode" and "function keys 1 and 2" are activated if checked and deactivated if unchecked.



Figure 5.19 Mode menu item

Designation	Function
Presentation mode	Mode of operation for presentation or testing without the assistance of a PC

Communication menu item

You can adjust the connection parameters between the sensor and computer under the **Communication** menu item.

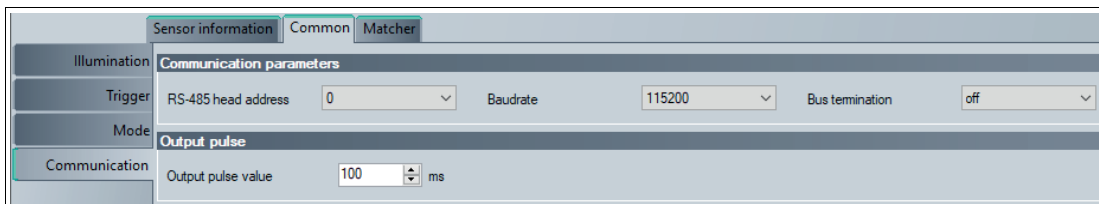

Figure 5.20 Communication menu item

Designation	Function
RS-485 head address	Address in the RS-485 bus. The address is sent with every RS485 command () and is used for identification purposes if multiple sensors are installed in the bus.
Baud rate	Data transfer speed setting. The default value of the sensor is 115200 bps. When you change the baud rate, the baud rate of the Vision Configurator is automatically changed so that communication remains possible.
Bus termination	Activates the integrated terminating resistor to terminate the RS-485 bus on the sensor
Output pulse value	Pulsed output: The output pulses from 0 to 1 and back to 0 according to the set pulse time. The pulse time must be lower than the reading time. The maximum output pulse value is 5 s. The default setting of the pulse time is 0 ms. The output remains constant until a change of state (e.g. after several good detections a false detection) occurs.

5.7.3 Matcher Tab

4 menu items are available under the **Matcher** tab. The purpose of this section is to present the menu items in detail.

Teach menu item

You can adjust the teach-in range of the sensor under the **Teach** menu item. The teach-in range allows you to restrict the range of the reference height profile. The required "Teach ROI" teach-in range is adjusted using the line profile under the "Diagram View" tab. The coordinates of the x and z axis are shown in the display field below the graphic.

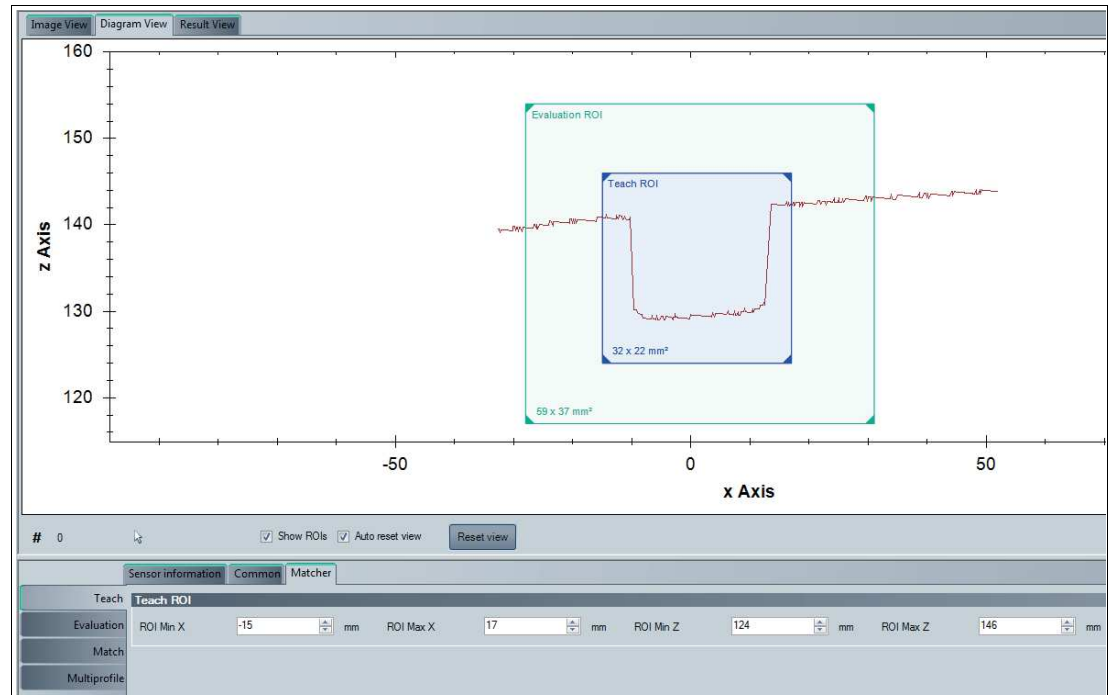

Figure 5.21 Teach menu item

Designation	Function
ROI Min X	the smallest value on the x axis
ROI Max X	the largest value on the x axis
ROI Min Z	the smallest value on the z axis
ROI Max Z	the largest value on the z axis

Evaluation Menu Item

You can adjust the sensor's evaluation range under the **Evaluation** menu item. The evaluation range is the range in which the sensor seeks out the taught-in height profile. The required "Evaluation ROI" evaluation range is adjusted using the line profile under the "Diagram View" tab. The coordinates of the x and z axis are shown in the display field below the graphic.

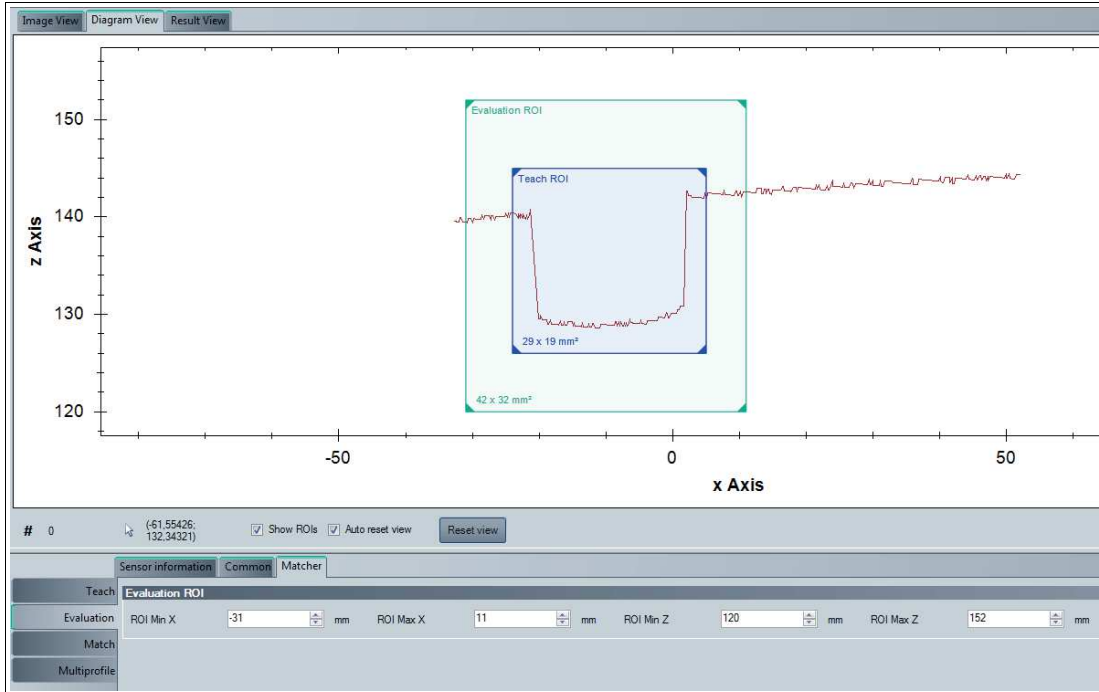

Figure 5.22 Evaluation Menu Item

Designation	Function
ROI Min X	the smallest value on the x axis
ROI Max X	the largest value on the x axis
ROI Min Z	the smallest value on the z axis
ROI Max Z	the largest value on the z axis

Note

Setting the Frame Size

Moving the teach-in range and evaluation range

This gives you the option to move the teach-in range and evaluation range. To do this, click with the left mouse button in the teach-in range or evaluation range. The frame of the selected area is shown as a dashed line. Hold down the mouse button and the window moves as you move the mouse. Release the mouse button at the position where you want to place the window. The coordinates in the display field are updated automatically.

Minimizing/maximizing the teach-in range and evaluation range

This gives you the option to broaden or narrow the teach-in range and evaluation range or to decrease or increase the height. Move the mouse to any edge of the frame until the mouse cursor changes. This turns into an arrow with 2 ends. When the mouse cursor has changed, click and hold with the left mouse button and move the mouse until the window is the desired width and/or height. The size can be changed on all 4 edges, and at the corners, too. The mouse cursor changes to a diagonal double arrow at the corners and changes the height and width in the same ratio. The coordinates in the display field are updated automatically.



Match Menu Item

You can adjust the x and z tolerance range for the sensor under the **Match** menu item. The tolerance range determines by how much the height profile may move within the evaluation range and still be recognized.

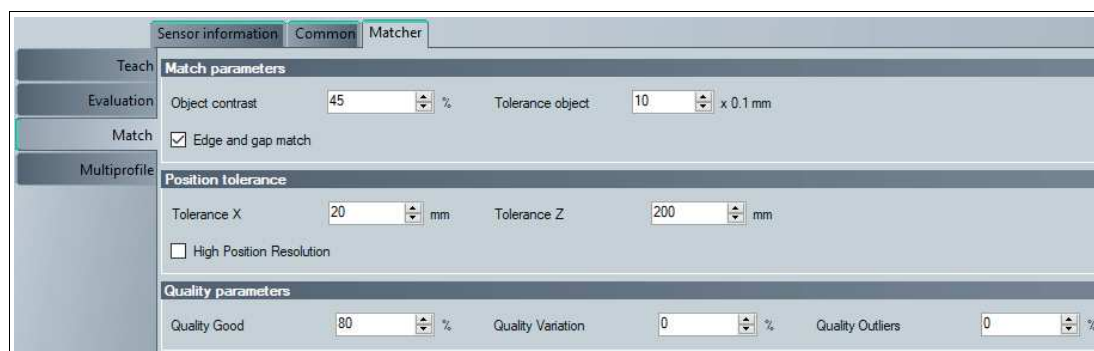

Figure 5.23 Match Menu Item

Designation	Function
Object contrast	Contrast threshold used to detect the laser line on the object.
Tolerance object	"Tolerance object" is used to input the width of the envelope curve around the taught-in object in 0.1 mm increments. The envelope curve is the basis for the quality parameters. The width of the envelope curve should be selected so that all good part profiles are located within the envelope curve despite height profile deviations.
Edge and gap match	When "Edge and gap Match" is activated, the gaps contained in the teach area are taught in addition to the line. Use this setting if you want to teach in gaps or edges. In the default setting this parameter is switched off.
Tolerance X	Maximum permitted displacement of the object within the evaluation range in the X direction.
Tolerance Z	Maximum permitted displacement of the object within the evaluation range in the Z direction.
High Position Resolution	Activating the "High Position Resolution" function via the checkbox causes the position tolerance to be output in 0.1 mm steps in x and z direction. In the standard setting, "High Position Resolution" is deactivated.
Quality Good	Quality threshold that distinguishes good parts from bad parts.
Quality Variation	Quality threshold that distinguishes good parts from bad parts.
Quality Outliers	Quality threshold that distinguishes good parts from bad parts.



Note

More information about the **Quality parameters** can be found in the chapter on image display under **Result View** (see chapter 5.6).

High Position Resolution

By activating the "High Position Resolution" function, the position is output in 0.1 mm steps instead of 1 mm steps. As soon as you activate the function, the unit changes from "mm" to "1/10 mm". Please note that the X and Z positions in the "Result View" window are not automatically converted to the 0.1 mm steps. Therefore, you must convert the values yourself. In the following figure, the "High Position Resolution" function is activated and the determined X and Z position values must therefore be converted:

- X position 10 >> **1 mm**
- Z position 6 >> **0.6 mm**

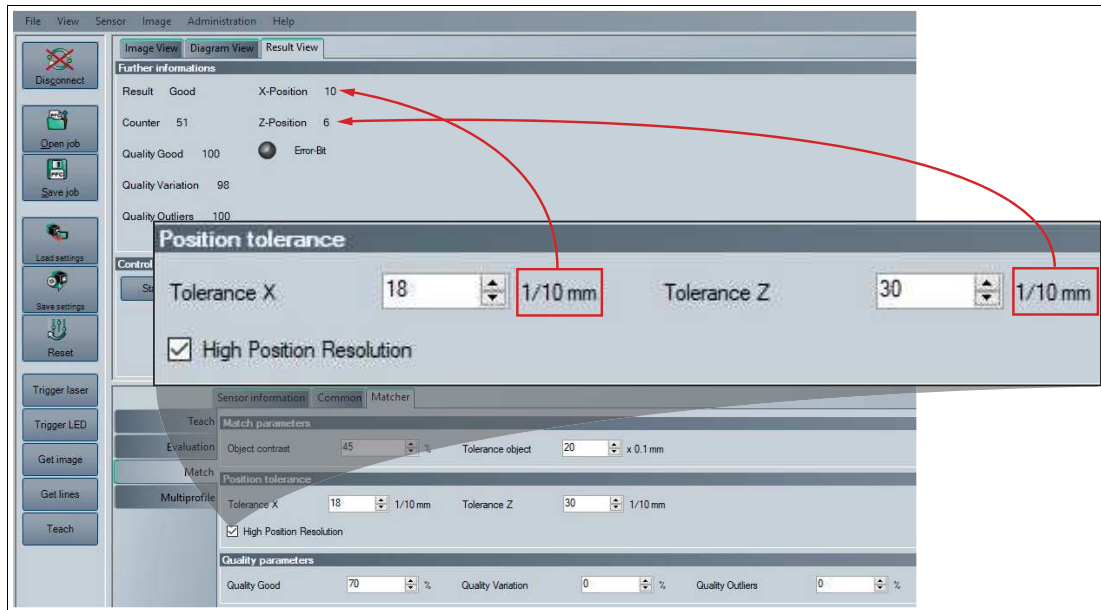

Note

We recommend to activate the function "High Position Resolution" if you use a sensor with higher resolution (e.g. VLM350-F280-R4-1101) and the working distance is shorter than 120 mm.

Even a SmartRunner-Matcher with standard resolution can be operated in "High Position Resolution" mode. In this case a very small distance and a larger teach-in range is recommended. If this is not observed, the output values may jump considerably when the "High Position Resolution" mode is activated. This occurs especially with larger distances, standard resolution and a small teach-in range.

Note

Please note that the "High Position Resolution" function can only be activated in the Vision Configurator and not in the wizard. If you have activated the "High Position Resolution" function in the Vision Configurator, it is also used in the wizard.

Multiprofile menu item

The following description applies to all SmartRunner Matcher except type VLM350-F280-2E2-1000. You can save different profiles under the **Multiprofile** menu item. The stored profiles can be retrieved at any time. You have the option to create up to 32 different profiles. This means you are in a position to respond quickly and flexibly in the case of frequent adjustments to production in particular.

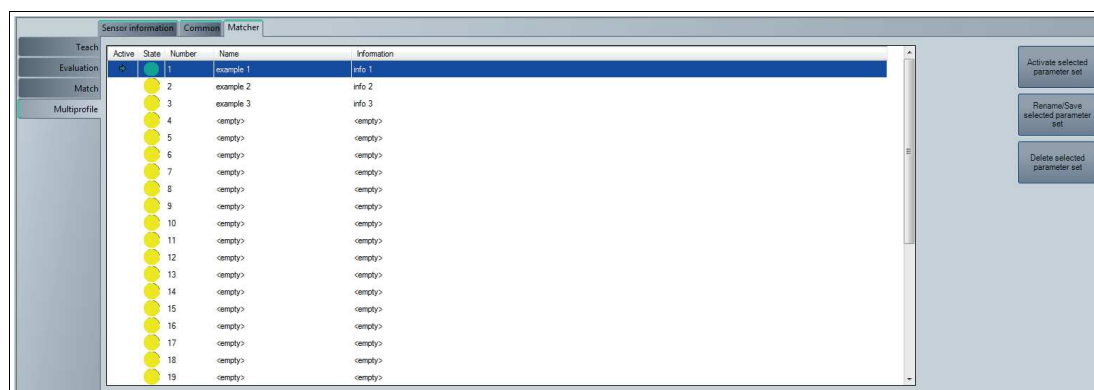

Figure 5.24 Multiprofile menu item

The information window consists of 5 columns and 3 buttons. These are explained in more detail in the following table:

Information window

Designation	Function
Active	The activated profile is marked by a green arrow. A profile is activated using the Active selected parameter set button. For this purpose, the desired profile is selected by clicking with the right mouse cursor and activated using the Active selected parameter set button.
State	The status light changes from yellow to green as soon as a new profile is created and confirmed using the Rename/Save selected parameter set button.
Number	Profile number
Name	The profile name is modified using the Rename/Save selected parameter set button. Enter the required profile name in the Parameter set name input field and confirm with OK .
Information	Information about the profile can be entered in the information field. The information is entered using the Rename/Save selected parameter set button. Enter the required information in the Parameter set information input field and confirm with OK .

Save Parameter Settings

The following description applies to all SmartRunner Matcher except type VLM350-F280-2E2-1000. The **Save job** function is used to save parameter data to a read/write tag. This makes it possible to save settings for different profiles on a read/write tag. You have the option to load the saved parameters at any time on your sensor. 3 different file types are available to save the parameters on a read/write tag.

The file types have the following properties:

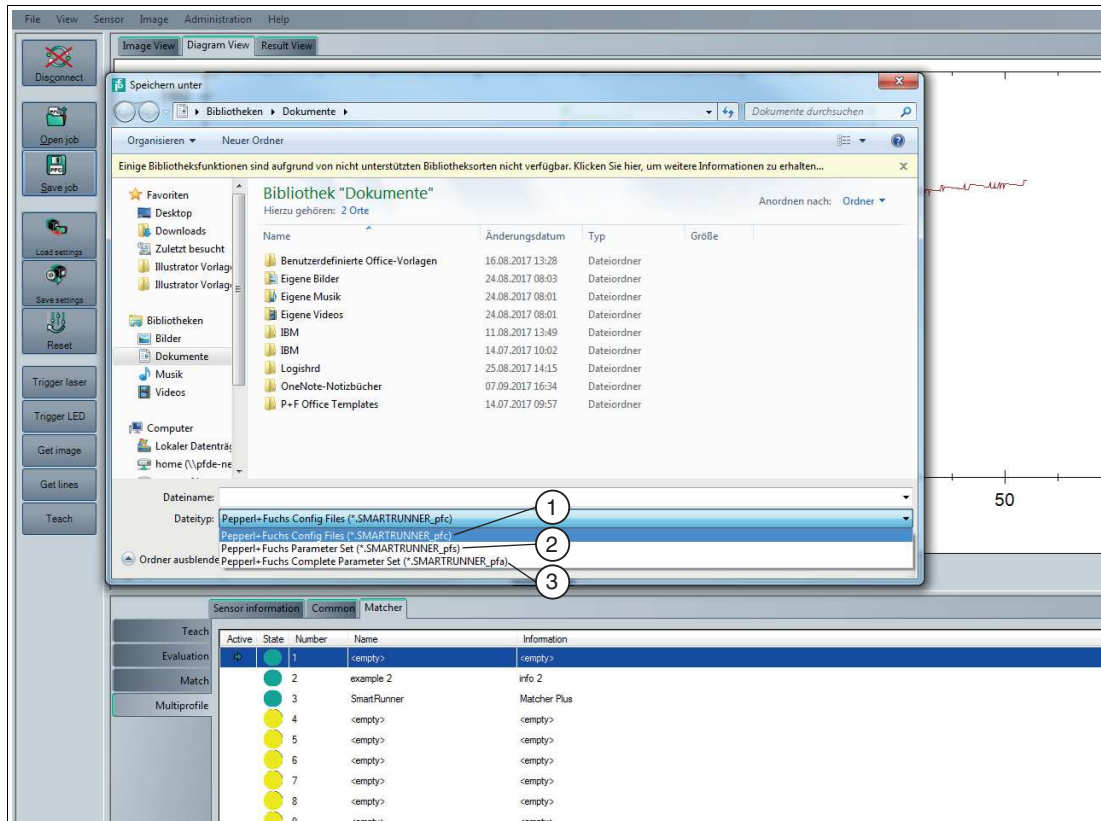

Figure 5.25 Save Parameter Settings

Position	Designation	Function
1	Pepperl+Fuchs Config Files (*.SMARTRUNNER_pfc)	Saves all parameter settings including communication parameters for 1 profile
2	Pepperl+Fuchs Parameter Set (*.SMARTRUNNER_pfs)	Saves all parameter settings without communication parameters for 1 profile
3	Pepperl+Fuchs Complete Parameter Set (*.SMARTRUNNER_pfa)	Saves all parameter settings without communication parameters for 32 profiles

Note

A parameter file stored on the read/write tag can only be opened using the **Vision Configurator** software.

Note

Please note that the transferred parameter files overwrite the current parameters on the **Vision Configurator** software. This can lead to data being lost.

6 Operation

The light section sensor is factory pre-configured to a specific application. As a result, it does not deliver raw data that needs to be evaluated first, but switching signals that are simple to process. The sensor only needs to be mounted, connected, and parameterized using teach-in. The sensor has 4 different operating modes, which can be activated for settings, presentation, or normal operation.

The following provides more detailed information about the operating modes.

6.1 Configuration Mode

Configuration protocol in configuration mode

To adjust the sensor, it must be in configuration mode.

The command to put the sensor in this mode is 0xA8 0x57. After successfully changing mode, the sensor responds with an Acknowledge (0x81 0xAC 0x00 0x2D). After an error when converting the configuration, the sensor responds with a No Acknowledge (0x81 0x53 0xXX 0xYY, where XX = error code and YY = checksum). To check whether the sensor is in configuration mode, the command Is_In_Config_Mode (0x00 0xFE 0xFE) can be sent. If the sensor is in configuration mode, it responds with an Acknowledge. Otherwise there is no response.

Error codes with "No Acknowledge":

- 0x00 = everything OK
- 0x01 = checksum incorrect
- 0x04 = parameter has a different length than that transferred
- 0x05 = internal error
- 0x06 = parameter index is unknown
- 0x07 = read/write access, although not allowed
- 0x09 = parameter value range is violated
- 0x0B = other error
- 0x0E = configuration command too long/short

In this mode, messages are sent according to the extended protocol:

Byte/bit	7	6	5	4	3	2	1	0
1	R/W	Length6	Length5	Length4	Length3	Length2	Length1	Length0
2	Index7	Index6	Index5	Index4	Index3	Index2	Index1	Index0
3	Data 1.7	Data 1.6	Data 1.5	Data 1.4	Data 1.3	Data 1.2	Data 1.1	Data 1.0
...
n	Data (n-2).7	Data (n-2).6	Data (n-2).5	Data (n-2).4	Data (n-2).3	Data (n-2).2	Data (n-2).1	Data (n-2).0
n+1	xor B1.7...B (n).7	xor B1.6...B (n).6	xor B1.5...B (n).5	xor B1.4...B (n).4	xor B1.3...B (n).3	xor B1.2...B (n).2	xor B1.1...B (n).1	xor B1.0...B (n).0

Table 6.1 R/W:
 0: write
 1: read/command
 Length: row data length (Data1 ... Data(n-2))

Description of Messages

Index	Parameter name	Data Length/bytes	Read/write	Description
0xA8	GotoParamMode	0	W	Puts the sensor in Configuration mode
0x01	VendorName	Variable	R	String containing "Pepperl+Fuchs"
0x02	VendorHomepage	Variable	R	String containing the Pepperl+Fuchs homepage
0x03	ProductName	Variable	R	String containing the product name
0x07	SoftwareVersionDSP	Variable	R	String containing the version information
0xFE	InParamMode	0	R	Queries whether the sensor is in parameterization mode
0xFF	LeaveParamMode	0	W	Request to exit parameterization mode
0x20	Interface_Address	1	R/W	Set the bus address, value range 0 – 3
0x23	Interface Baudrate	4	R/W	Baud rate int32 little-endian in baud (9600 - 230400)
0x25	Termination enable	4	R/W	Enable/disable termination of the RS-485 bus
0x68	Laser exposure time	4	R/W	Sets the exposure time in μ s increments
0x10	Flash time	4	R/W	Sets the exposure time (LED lighting) in μ s
0xFD	Presentation mode	4	R/W	Presentation mode on [1] or off [0]
0x6D	Go to teach mode	0	W	Puts the sensor in teach-in mode
0xC8	ROI Evaluation	16	R/W	"Region of interest" evaluation, 4 bytes in each case: X_{min} , X_{max} , Z_{min} , Z_{max} in mm
0xC9	ROI Teach	16	R/W	"Region of interest" for teach-in, 4 bytes in each case: X_{min} , X_{max} , Z_{min} , Z_{max} in mm
0xAD	Quality Good	4	R/W	Threshold for the part of the contour that must be within the variation, in % [0 – 100]
0xAE	Quality Variation	4	R/W	Threshold for the average deviation from the taught-in curve, in % [0 – 100]
0xAF	Quality Outliers	4	R/W	Gage for assessing the quality of the curve, in % [0 – 100]. The value worsens if parts of the curve are detected as being outside the envelope
0x51	Autotrigger	4	R/W	Activates the autotrigger function. With auto trigger, the sensor triggers itself cyclically 00 = off 01 = on
0x9F	Object contrast	4	R/W	Threshold used for detecting the laser line, in % [0 – 100]
0xCD	Tolerance object	1	R/W	Envelope around the taught-in profile in 0.1 mm increments. The envelope is the basis for the quality parameters
0x29	Tolerance X	4	R/W	Maximum permissible deviation of the object in the X direction relative to the taught-in position in mm

Index	Parameter name	Data Length/bytes	Read/write	Description
0x38	Tolerance Z	4	R/W	Maximum permissible deviation of the object in the Z direction relative to the taught-in position in mm
0x54	Set/Get Profile name ¹	0 – 32	R/W	Write/read a name for the current profile.
0x55	Get Profile index ¹	0	R	Returns the index of the currently active profile.
0x56	Set/Get Profile information ¹	255	R/W	Set/retrieve profile information.
0x32	Edge and Gap Match	1	R/W	Activation of edge and gap matching
0x28	High Position Resolution	1	R/W	X-Z output in 0.1 mm steps
0xCE	Output pulse	4	R/W	Setting the pulse length of the good and bad output pulse in ms (from 5 ms up to 5 s).

Save settings

01 F3 10 E2

Saves the current settings in the flash memory

Reset

01 F3 02 F0

Returns to default settings.

Load settings

01 F3 00 F2

The current order and the settings are reloaded.

Switch to Profile¹

02 F3 03 XX XOR

XX = profile number (1...32)

Example: profile number [2]: 02 F3 03 02 F0

Trigger Laser

01 64 01 XOR

Triggers an image capture with evaluation

Trigger LED

01 64 02 XOR

Triggers the LEDs

Edge and Gap Match

01 32 01 32 (hex) activated for gaps

01 32 00 33 (hex) without gaps, i.e. as before

1. applies to all SmartRunner Matcher except type VLM350-F280-2E2-1000

High Position Resolution

0x01 0x28 0x00 0x29 Set resolution mode low (= 0)

0x01 0x28 0x01 0x28 Set resolution mode high (= 1)

0x80 0x28 0xA8 Request the status of "High Position Resolution"

Output pulse

0x04 0xCE 0x05 0x00 0x00 0x00 0xCF sets the pulse length to 5 ms

0x80 0xCE 0x4E Request the status of Output pulse (returns the set pulse length)



Note

All values are transferred in little-endian format. In this case, the smallest value byte is stored at the starting address or the smallest value component named first. Read commands always have a length of 0 bytes.



Example

In this example, the ROI evaluation is set as follows: set the ROI to ± 50 mm in the X direction and to +100 mm to +200 mm in the Z direction.

```
0x 10 C8 CE FF FF FF 32 00 00 00 64 00 00 00 C8 00 00 00 77
```

0x10 = data length

0xC8 = index

0xCEFFFFFF = X_{\min} -50 mm (little-endian, two's complement)

0x32000000 = X_{\min} +50 mm (little-endian, two's complement)

0x64000000 = Z_{\min} +100 mm (little-endian, two's complement)

0xC8000000 = Z_{\min} +200 mm (little-endian, two's complement)

Response telegram:

```
[TX] -80 C8 48
```

```
[RX] -90 C8 CE FF FF FF 32 00 00 00 64 00 00 00 C8 00 00 00 F7
```



Example

In this example, the sensor is transferred to Parameter mode to change some settings. Afterwards it switches to Runtime mode, a profile is taught in, and a comparison is made between this profile and another profile (object_1 differs greatly from object_2).

```
[TX] - A8 57 = GotoParamMode
```

```
[RX] - 81 AC 00 2D = Acknowledge
```

```
[TX] - 00 FE FE = InParamMode
```

```
[RX] - 81 AC 00 2D = Acknowledge
```

```
[TX] - 80 AD 2D = Read Quality Good
```

```
[RX] - 84 AD 50 00 00 00 7F = Quality Good=80 (0x50)
```

```
[TX] - 04 AD 55 00 00 00 FB = Write Quality Good=85 (0x55)
```

```
[RX] - 81 AC 00 2D = Acknowledge
```

```
[TX] - 04 51 00 00 00 00 55 = Write Autotrigger = Off
```

```
[RX] - 81 AC 00 2D = Acknowledge
```

```
[TX] - 01 F3 10 E2 = Save settings
```

```
[RX] - 81 AC 00 2D = Acknowledge
```

[TX] - D8 27	= Trigger
[TX] - 90 6F	= Teach Result
[RX] - 00 00 00 64 00 00 00 64	= Result=Good
[TX] - D8 27	= Trigger (Object_1)
[TX] - 84 7B	= Result Data
[RX] - 00 01 4C 64 64 64 00 00 00 00 29	= Result Data=Good
[TX] - D8 27	= Trigger (Object_2)
[TX] - 84 7B	= Result Data
[RX] - 02 00 4D 50 4A 51 00 01 00 00 05	= Result Data=Bad
Multiprofile:	
[TX] - A8 57	= GotoParamMode
[RX] - 81 AC 00 2D	= Acknowledge
[TX] - 02 F3 03 02 F0	= Switch to Profile 2
[RX] - 81 AC 00 2D	= Acknowledge
[TX] - 03 54 42 61 72 06	= Set Profile Name to "Bar"
[RX] - 81 AC 00 2D	= Acknowledge
[TX] - 13 56 54 68 69 73 20 69 73 20 74 68 65 20 42 61 72 20 6A 6F 62 36	= Set Profile information to "This is the Bar job"
[RX] - 81 AC 00 2D	= Acknowledge
[TX] - 80 55 D5	= Read Profile index
[RX] - 81 55 02 D6	= Job index = 2 (0x02)
[TX] - 04 51 00 00 00 00 55	= Write Autotrigger=Off
[RX] - 81 AC 00 2D	= Acknowledge
[TX] - 01 F3 10 E2	= Save settings
[RX] - 81 AC 00 2D	= Acknowledge
[TX] - 00 6D 6D	= Go to teach mode (Object_2)
[RX] - 81 AC 00 2D	= Acknowledge
[TX] - 01 64 01 64	= Write Trigger
[RX] - 81 AC 00 2D	= Acknowledge
[TX] - 00 FF FF	= LeaveParamMode
[RX] - 81 AC 00 2D	= Acknowledge
[TX] - D8 27	= Trigger (Object_2)
[TX] - 84 7B	= Result Data
[RX] - 00 02 11 64 64 64 00 00 00 00 77	= Result Data=Good
[TX] - D8 27	= Trigger (Object_2 shifted in X direction)
[TX] - 84 7B	= Result Data
[RX] - 00 02 12 64 63 64 00 06 00 00 75	= Result Data=Good
[TX] - D0 01 01 2F	= choose Profile 1
[TX] - D8 27	= Trigger (Object_1)

[TX] - 84 7B

= Result Data

[RX] - 00 01 13 64 64 64 00 00 00 00 5D

= Result Data=Good

Description of Quality Parameters

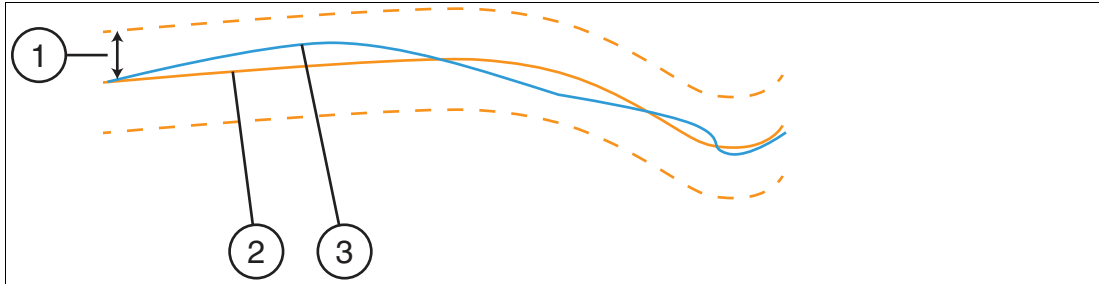

- 1 Variation
- 2 Learned curve
- 3 Current curve

$$\text{Quality Variation} = 100 - \sum_{x=0}^{X_T} \left(\frac{\text{Min}(z_s(x)-z_T(x);v)}{v} \right) * 100$$

$$\text{Quality Good} = 100 - \left(\frac{X_N+X_B+X_L}{X_T} \right) * 100$$

$$\text{Quality Outliers} = 100 - \left(\frac{X_B}{X_T} \right) * 100$$

Legend

- X_T Number of values in the taught-in profile curve
- $Z_T(x)$ Distance value of the taught-in profile at position x
- $Z_s(x)$ Distance value of the current profile at position x
- v Set variation
- X_N Number of values detected during evaluation, although not present during teach-in
- X_B Number of values that lie outside of the envelope
- X_L Number of values that were present during teach-in, but can no longer be found during evaluation

6.2 Code Card Mode

The built-in camera function including LED lighting allows for parameterization using Data Matrix control codes. The control codes are generated using the "Vision Configurator" operating software. All sensor parameters can be specified in a Data Matrix control code. For this purpose, the Data Matrix control code is placed in front of the camera. The control code is registered immediately and decoded. The sensor automatically activates the parameters contained within. So a large number of sensors can be put into operation easily and quickly.



Tip

It is also possible to generate control codes when no sensor is connected to Vision Configurator. In this case, you can, for example, generate a control code to assign a particular IP address to a sensor and then establish a connection with a PC.



Generating a control code

1. In the menu bar, select **Administration > Create reader programming code**.
2. In the **Device type** section, select sensor type **SMARTRUNNER**.
3. Select the required parameters in the **Select function** section.
↳ The control code is displayed in different sizes in the **Control Code** section.
4. To print the control code, click **Print** or **Print preview**.
To save the control code, click **Save image**.

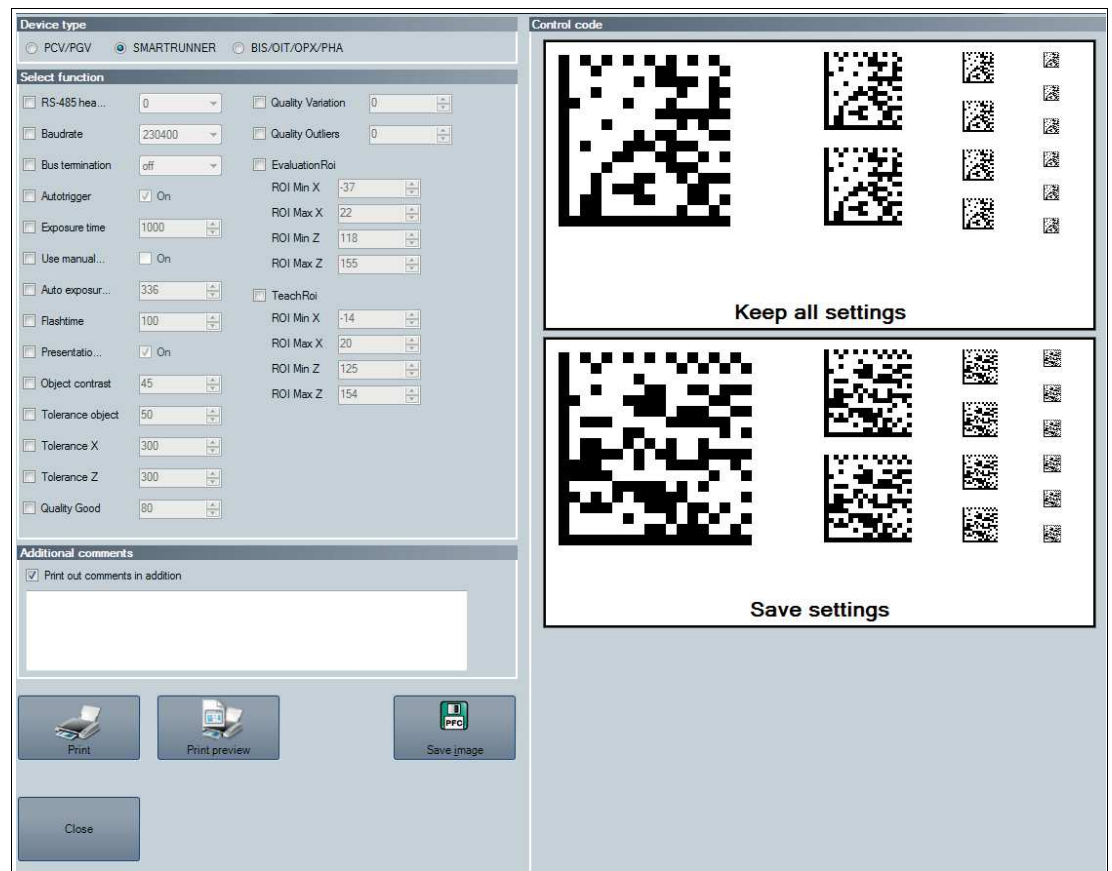

Figure 6.1 Generating a control code

6.2.1 Setting Device Parameters via Control Code

Use Vision Configurator to generate control codes.



Note

Parameterization mode can be activated only within 10 minutes of the sensor being switched on.



Enabling Code Card Mode

Hold down the **2** button on the back of the sensor for more than 2 seconds. Then release the button.

↳ The Ready LED flashes rapidly and the sensor's camera system begins to flash.



Setting Parameters

1. To assign a parameter, position the relevant control code in the sensor's field of view.
 - ↳ If a valid code is detected, the Result LED lights up green briefly
If an invalid code is detected, the Result LED lights up red briefly
2. The modified parameter is now saved in the sensor's volatile memory. The "Save settings" control code saves the parameter in the non-volatile memory if necessary.



Disabling Code Card Mode

Press the **2** button on the back of the sensor.

↳ The Ready LED stops flashing and the camera system stops flashing.

6.3 Presentation Mode

You can demonstrate or test the sensor in Presentation mode without the assistance of a PC. Furthermore, the control buttons are activated/deactivated.



Setting Presentation Mode

1. Connect the sensor to a power supply.
2. Align the sensor to the measurement object.
3. Teach in the measurement object by tapping button 2 on the sensor.



Figure 6.2 Result LED

↳ The result LED lights up red.

4. Press button 1.

↳ The trigger is activated. The result LED lights up green. The measurement object is taught in.

The result LED lights up red if the profile contour deviates.



Note

If the autotrigger is activated in the Vision Configurator operating software, you just need to press button 2 to teach in the measurement object. If the autotrigger is deactivated, the trigger must be activated by pressing button 1 once the measurement object has been taught in.

6.4 Runtime Mode

The Runtime mode is the main mode in which the measuring process operates as configured in the operating software.

6.4.1 Communication via the RS-485 Interface

The control panel and reader communicate via the RS-485 interface during operation. Make sure that the basic communication settings have been made on the reader, such as setting the reader address and baud rate.

A distinction is made between request telegrams that the control panel sends to the reader and response telegrams that the reader sends to the control panel. Each byte of a request or response telegram consists of 9 bits (8 data bits + 1 parity bit).

Parity Bit

A bit assigned to a binary string used to detect errors. It is added in such a way that the sum modulo 2 of all bits that are regarded as binary digits in the string, including the parity bit, is either 0 or 1 depending on the requirement; additional bit that is added to each string or each byte for control purposes so that the sum of all bits containing binary 1 in the characters or bytes including control bit results in an odd or even value.

Request Telegram

A request telegram always consists of 2 bytes. The 2nd byte corresponds to the 1st byte; however, the 8 data bits of the 1st byte are inverted.

Structure of a Request Telegram

	Bit 7	Bit 6	Bit 5	Bit 4	Bit 3	Bit 2	Bit 1	Bit 0
Byte 1	R/W	Req. bit 4	Req. bit 3	Req. bit 2	Req. bit 1	Req. bit 0	A1	A0
Byte 2	~R/W	~Req. bit 4	~Req. bit 3	~Req. bit 2	~Req. bit 1	~Req. bit 0	~A1	~A0

Meaning of bits:

R/W: 0 = response, 1 = request

Meaning of Bits

7	6	5	4	3	2	1	0	<- Bit	
R/W	R.4	R.3	R.2	R.1	R.0	A.1	A.0	Value	Function
0	x	x	x	x	x	x	x		Answer
1	x	x	x	x	x	x	x		Request
1	x	x	x	x	x	0	0		Read head address 0
1	x	x	x	x	x	0	1		Read head address 1
1	x	x	x	x	x	1	0		Read head address 2
1	x	x	x	x	x	1	1		Reader address 3
1	0	0	0	0	0	x	x	0x80	Status (is alive)
1	0	0	0	0	1	x	x	0x84	Result data
1	0	0	1	0	0	x	x	0x90	Teach result
1	0	1	0	1	0	x	x	0xA8	Enable Configuration Mode
1	0	0	1	0	1	x	x	0x94	Enable Teach Mode
1	1	0	1	1	0	x	x	0xD8	Generate a software trigger
1	1	0	1	0	0	x	x	0xD0	Choose Profile ¹

1. Applies to all SmartRunner Matcher except type VLM350-F280-2E2-1000

Response Telegram

Status (is alive)

The status always returns 0x55 if the sensor is ready for operation.

	7	6	5	4	3	2	1	0
Byte	R/W	R.4	R.3	R.2	R.1	R.0	A.1	A.0
1	0	1	0	1	0	1	0	1

Result Protocol

Result Data provides the measurement status and result as a response.

Byte	Bit 7	Bit 6	Bit 5	Bit 4	Bit 3	Bit 2	Bit 1	Bit 0
Byte 1 - Status	0	-	Addr 1	Addr 0	Event	WRN	No Match	ERR
Byte 2 - Result	0	R6	R5	R4	R3	R2	R1	R0
Byte 3 - Counter	0	C06	C05	C04	C03	C02	C01	C00
Byte 4 - Quality	0	Q06	Q05	Q04	Q03	Q02	Q01	Q00
Byte 5 - Quality	0	Q16	Q15	Q14	Q13	Q12	Q11	Q10
Byte 6 - Quality	0	Q26	Q25	Q24	Q23	Q22	Q21	Q20
Byte 7 - PosX	0	PosX13	PosX12	PosX11	PosX10	PosX09	PosX08	PosX07
Byte 8 - PosX	0	PosX06	PosX05	PosX04	PosX03	PosX02	PosX01	PosX00
Byte 9 - PosZ	0	PosZ13	PosZ12	PosZ11	PosZ10	PosZ09	PosZ08	PosZ07
Byte 10 - PosZ	0	PosZ06	PosZ05	PosZ04	PosZ03	PosZ02	PosZ01	PosZ00
Byte 11 - Checksum	0	xor	xor	xor	xor	xor	xor	xor

Legend

Status	Addr	Device address
	Event	Event occurred (future) Currently read as 0
	WRN	Unused
	No Match	Profile does not match the saved profile
	ERR	System error or evaluation error
Result	R0 ... R6	Active profile number 1 ... 32 The active profile number is returned also if the profile match was negative.
Quality	Q00 ... Q26	Quality of the current profile (0 = no profile found, 100 = perfect match) Quality: Quality Good Quality2: Quality Variation Quality3: Quality Outliers
Counter		Increments for each evaluation, is restarted at 0x3F
Position Data ¹	PosX13 ... PosX00	X-deviation of current profile to saved profile
	PosZ13 ... PosZ00	Z-deviation of current profile to saved profile

1. applies to all SmartRunner Matcher except type VLM350-F280-2E2-1000

Example for PosX und PosZ

Result Protocol - PosX und PosZ

Byte	Bit 7	Bit 6	Bit 5	Bit 4	Bit 4	Bit 2	Bit 1	Bit 0
Byte 7 - PosX	0	PosX13	PosX12	PosX11	PosX10	PosX09	PosX08	PosX07
Byte 8 - PosX	0	PosX06	PosX05	PosX04	PosX03	PosX02	PosX01	PosX00
Byte 9 - PosZ	0	PosZ13	PosZ12	PosZ11	PosZ10	PosZ09	PosZ08	PosZ07
Byte10- PosZ	0	PosZ06	PosZ05	PosZ04	PosZ03	PosZ02	PosZ01	PosZ00

Example with negative sign for **PosX**:

Byte	Bit 7	Bit 6	Bit 5	Bit 4	Bit 4	Bit 2	Bit 1	Bit 0
Byte 7 - PosX	0	1	1	1	1	1	1	1
Byte 8 - PosX	0	1	1	0	1	1	0	0

1. Determine sign
1: -
0: +

2. Move the fixed zero (Bit 7)

3. NOT-Operation (invert)

4. Link with 3FFF

5. AND-Operation

6. Add 1

```

0011 1111 0110 1100  v (=Value)
1100 0000 0001 0011  NOT v
0011 1111 1111 1111  3FFF
-----
0000 0000 0001 0011  (NOT v) AND 3FFF
0000 0000 0000 0001  + 1
-----
BIN 0000 0000 0001 0100  ((NOT v) AND 3FFF) + 1
HEX 14
DEC 20 * (-1) = -20 (X-axis)
    
```

Example with positiv sign for **PosZ**:

Byte	Bit 7	Bit 6	Bit 5	Bit 4	Bit 4	Bit 2	Bit 1	Bit 0
Byte 9 - PosZ	0	0	0	0	0	0	0	0
Byte10 - PosZ	0	0	0	1	0	0	0	1

1. Determine sign
1: -
0: +

2. Move the fixed zero (Bit 7)

```

BIN 0000 0000 0001 0001  v (=Value)
HEX 11
DEC 17 (Z-axis)
    
```

Figure 6.3 Example calculation

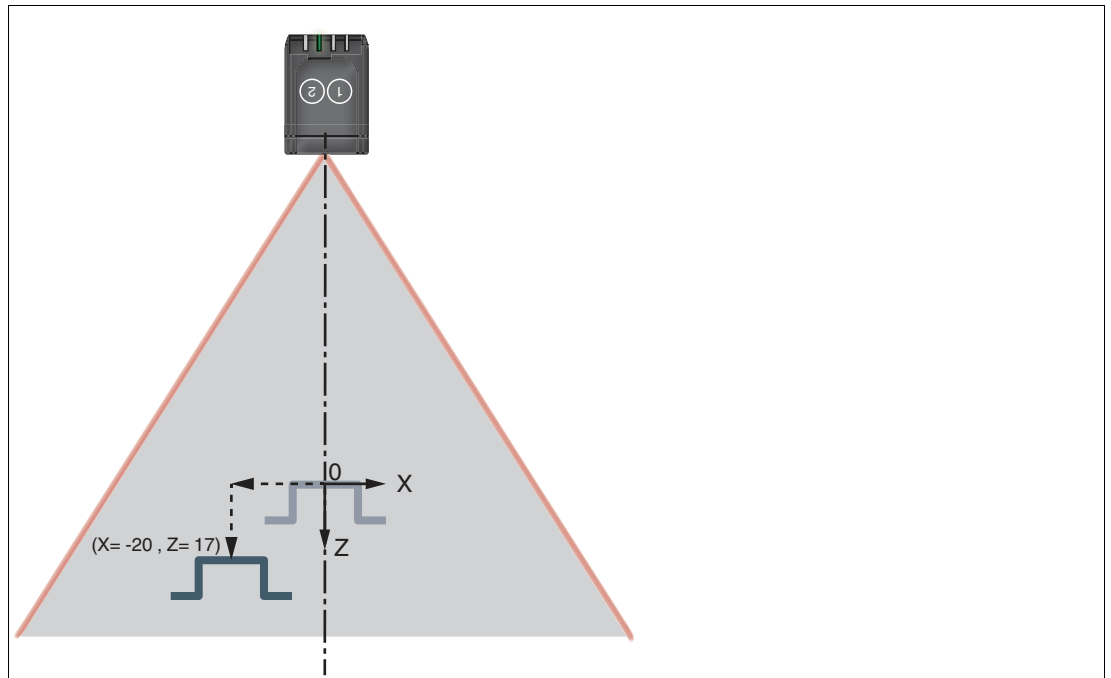

Figure 6.4 Displacement (X = -20, Z = 17)

Teach Result Protocol

Teach Result Data returns the status and result of the teach-in process as a response.

Byte	Bit 7	Bit 6	Bit 5	Bit 4	Bit 3	Bit 2	Bit 1	Bit 0
Byte 1 - Status	0	-	Addr 1	Addr 0	Event	WRN	0	ERR
Byte 2 - Result	0	0	0	0	0	0	0	0
Byte 3 - Counter	0	C06	C05	C04	C03	C02	C01	C00
Byte 4 - Quality A	0	QA6	QA5	QA4	QA3	QA2	QA1	QA0
Byte 5 - Quality B	0	QB6	QB5	QB4	QB3	QB2	QB1	QB0
Byte 6 - Quality C	0	QC6	QC5	QC4	QC3	QC2	QC1	QC0
Byte 7 - Quality D	0	QD6	QD5	QD4	QD3	QD2	QD1	QD0
Byte 8 - Checksum	0	xor	xor	xor	xor	xor	xor	xor

Legend

Status	Addr	Device address
	Event	Event has occurred - for future use, currently read as 0
	WRN	Unused
	ERR	System error or evaluation error
Result	R0	For extended protocol Always 0
Counter	C00 ... C06	Increments with each teach-in
Quality A		The quality of the current teach-in Values between 0 and 100 0 = teach-in not possible 100 = perfect teach-in
Quality B-D		Unused

Software Trigger

After sending the sequence for the software trigger, the sensor triggers an image capture. No response telegram is generated to the command.

Teach-In

After transmitting the command to start the teach-in (0x94), the sensor begins the teach-in routine. A trigger must subsequently be transmitted.

Choose profile¹

Byte	Bit 7	Bit 6	Bit 5	Bit 4	Bit 3	Bit 2	Bit 1	Bit 0
Byte 1 - Request	1	1	0	1	0	0	Address1	Address0
Byte 2 - Data length	0	0	0	0	0	0	0	1
Byte 3 - Data	0	0	P5	P4	P3	P2	P1	P0
Byte 4 - Checksum	~xor	~xor	~xor	~xor	~xor	~xor	~xor	~xor

Legend

Request	Bit 7 ... 2	Command ID
	Address	Address of the current device
Data	Bit 7	0
	Bit 6	0
	P5 ... P0	1 ... 32: Profile number 0... : not defined > 32: not defined

1. applies to all SmartRunner Matcher except type VLM350-F280-2E2-1000

7 Maintenance and Repair

7.1 Servicing



Danger!

Danger to life due to electrical current!

Contact with live parts causes immediate danger to life.

- Allow only qualified electricians to carry out work on the electrical installation.
 - Switch off the power supply before carrying out servicing, cleaning, and repairs, and prevent the supply from being switched on again.
 - Keep the live parts free from moisture.
-

The device is maintenance-free. To get the best possible performance out of your device, keep the optical unit on the device clean, and clean it when necessary.

Observe the following instructions when cleaning:

- Do not touch the optical unit with your fingers.
- Do not immerse the device in water. Do not spray the device with water or other liquids.
- Do not use abrasive agents to clean the surface of the device.
- Use a cotton or paper cloth moistened (not soaked) with water or isopropyl alcohol.
- Remove any residual alcohol using a cotton or paper cloth moistened (not soaked) with distilled water.
- Wipe the device surfaces dry using a lint-free cloth.

7.2 Repair

The device must not be repaired, changed, or manipulated. In case of failure, always replace the device with an original device.

8 Troubleshooting

8.1 What to Do in Case of a Fault

Before you have the device repaired, take the following actions:

- Test the plant according to the checklist below.
- Contact our service center to localize the problem.

Checklist

Fault	Cause	Remedy
"Power" LED does not light up	The power supply is switched off	Check whether there is a reason why the power supply is switched off (installation or maintenance work, etc.). Switch on the power supply if appropriate.
	Wiring fault in the splitter or control cabinet, cable break	Check the wiring carefully and repair any faults with the wiring. Check the cable to ensure proper function.
Control panel receiving no measurement data	Connection cable not connected	Connect the connection cable.
	Incorrect connection cable used	Use the appropriate connection cable only.
	Incorrect baud rate set	Make sure that you have set the correct baud rate for the sensor.
Measurement object not recognized	Protective cover dirty	Clean protective cover.
	Reflections	Avoid reflections
	Foreign exposure	Avoid foreign exposure
	Exposure time control	Set exposure (see chapter 5.7.2)
	Teach-in range set incorrectly	Set teach-in range (see chapter 5.7.2)
	Evaluation range set incorrectly	Set evaluation range (see chapter 5.7.2)
Measurement errors	Tolerance range set incorrectly	Set tolerance range (see chapter 5.7.2)
	Surfaces with pronounced scored structure and reflective surfaces	Improved arrangement of sensor components to the measurement object
	Temperature change in the sensor	Allow sensor to warm up for around 15 minutes before the measuring process is started.
	Incorrect distance to the measuring object	Note distance values
Presentation mode not working	Housing incorrectly mounted	Install housing correctly (see chapter 3.3)
	Presentation mode not activated	Enable Presentation mode and Autotrigger and confirm using "Save settings"
No connection to the sensor	AC voltage or supply voltage too high	Connect sensor to direct current (DC) only. Ensure that the level of supply voltage is within the specified sensor range.
Data Matrix control code is not detected	Maximum number of parameters exceeded	We recommend a maximum of 10 parameters

- If none of the above remedies the problem, please contact our service center. Please have the fault patterns and the version number of the firmware available. The firmware version number can be found at the top right of the user interface.

9 License Note

The SmartRunner sensor ships with firmware ("software") programmed into it. This software is based in part on the work of the Independent JPEG Group. The software is based on works by Texas Instruments Incorporated, which are distributed under the following licenses:

SYS/BIOS License

Copyright (c) 2012-2015, Texas Instruments Incorporated.
All rights reserved.

Redistribution and use in source and binary forms, with or without modification, are permitted provided that the following conditions are met:

* Redistributions of source code must retain the above copyright notice, this list of conditions, and the following disclaimer.

* Redistributions in binary form must reproduce the above copyright notice, this list of conditions, and the following disclaimer in the documentation and/or other materials provided with the distribution.

* Neither the name of Texas Instruments Incorporated nor the names of its contributors may be used to endorse or promote products derived from this software without specific prior written permission.

THIS SOFTWARE IS PROVIDED BY THE COPYRIGHT HOLDERS AND CONTRIBUTORS "AS IS" AND ANY EXPRESS OR IMPLIED WARRANTIES, INCLUDING, BUT NOT LIMITED TO, THE IMPLIED WARRANTIES OF MERCHANTABILITY AND FITNESS FOR A PARTICULAR PURPOSE ARE DISCLAIMED. IN NO EVENT SHALL THE COPYRIGHT OWNER OR CONTRIBUTORS BE LIABLE FOR ANY DIRECT, INDIRECT, INCIDENTAL, SPECIAL, EXEMPLARY, OR CONSEQUENTIAL DAMAGES (INCLUDING, BUT NOT LIMITED TO, PROCUREMENT OF SUBSTITUTE GOODS OR SERVICES; LOSS OF USE, DATA, OR PROFITS; OR BUSINESS INTERRUPTION) HOWEVER CAUSED AND ON ANY THEORY OF LIABILITY, WHETHER IN CONTRACT, STRICT LIABILITY, OR TORT (INCLUDING NEGLIGENCE OR OTHERWISE) ARISING IN ANY WAY OUT OF THE USE OF THIS SOFTWARE, EVEN IF ADVISED OF THE POSSIBILITY OF SUCH DAMAGE.

Eclipse Distribution License - v 1.0

Copyright (c) 2007, Eclipse Foundation, Inc. and its licensors.
All rights reserved.

Redistribution and use in source and binary forms, with or without modification, are permitted provided that the following conditions are met:

- Redistributions of source code must retain the above copyright notice, this list of conditions, and the following disclaimer.
- Redistributions in binary form must reproduce the above copyright notice, this list of conditions, and the following disclaimer in the documentation and/or other materials provided with the distribution.
- Neither the name of the Eclipse Foundation, Inc. nor the names of its contributors may be used to endorse or promote products derived from this software without specific prior written permission.

THIS SOFTWARE IS PROVIDED BY THE COPYRIGHT HOLDERS AND CONTRIBUTORS "AS IS" AND ANY EXPRESS OR IMPLIED WARRANTIES, INCLUDING, BUT NOT LIMITED TO, THE IMPLIED WARRANTIES OF MERCHANTABILITY AND FITNESS FOR A PARTICULAR PURPOSE ARE DISCLAIMED. IN NO EVENT SHALL THE COPYRIGHT OWNER OR CONTRIBUTORS BE LIABLE FOR ANY DIRECT, INDIRECT, INCIDENTAL, SPECIAL, EXEMPLARY, OR CONSEQUENTIAL DAMAGES (INCLUDING, BUT NOT LIMITED TO, PROCUREMENT OF SUBSTITUTE GOODS OR SERVICES; LOSS OF USE, DATA, OR PROFITS; OR BUSINESS INTERRUPTION) HOWEVER CAUSED AND ON ANY THEORY OF LIABILITY, WHETHER IN CONTRACT, STRICT LIABILITY, OR TORT (INCLUDING NEGLIGENCE OR OTHERWISE) ARISING IN ANY WAY OUT OF THE USE OF THIS SOFTWARE, EVEN IF ADVISED OF THE POSSIBILITY OF SUCH DAMAGE.

10 Appendix

10.1 Code Cards for Profile Changing

Here, you can find the code cards that enable you to switch between the profiles. For the exact external parameterization procedure see chapter 6.2.1.



Note

When performing external parameterization with code cards, we recommend copying and printing out the relevant pages in this manual and cutting out the code cards. This prevents the read head from mistakenly detecting another code card on the same page. If you intend to use this manual directly for parameterization, cover the code cards that you do not require with a sheet of paper, for example.

Profile 1

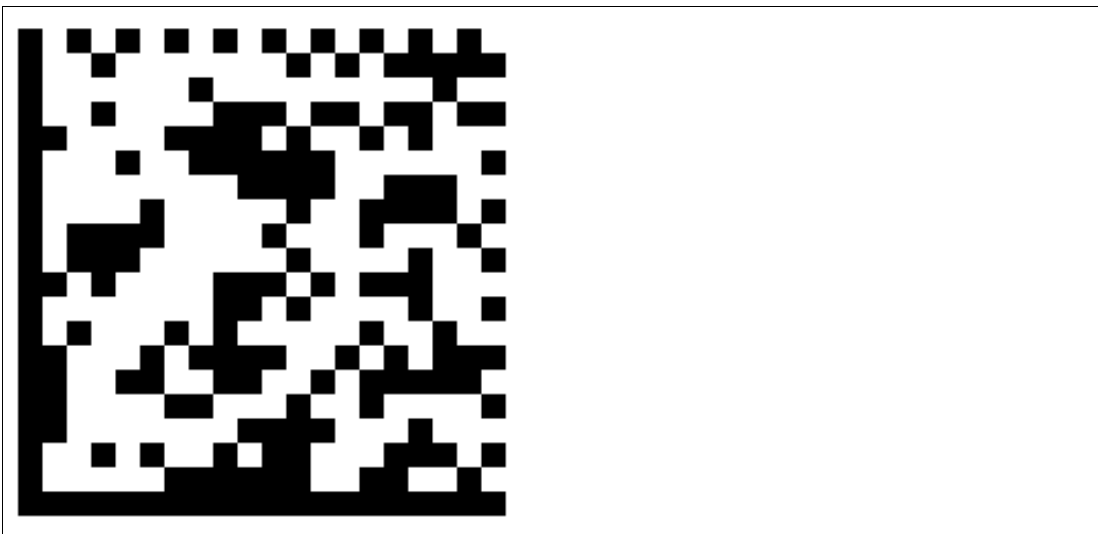

Figure 10.1 Profile 1

Profile 2

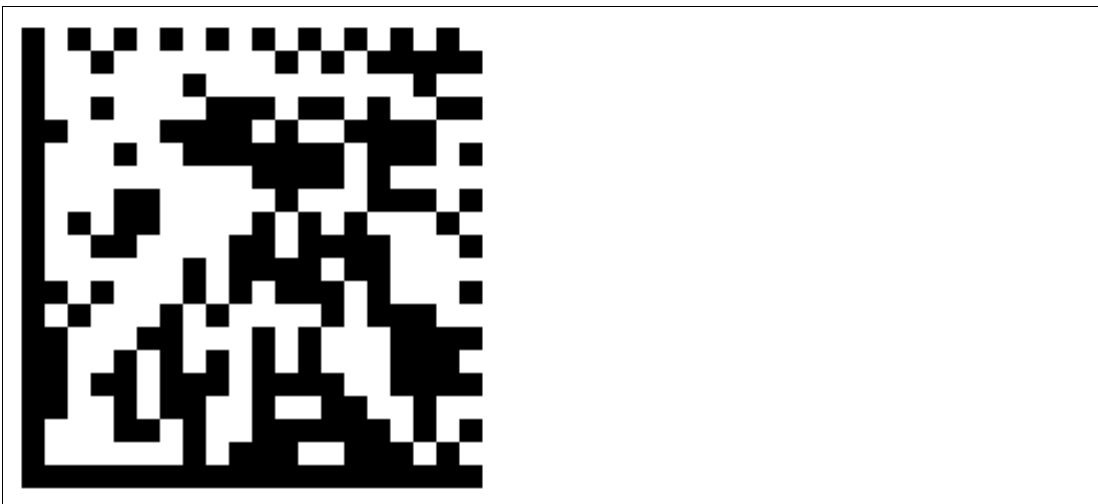

Figure 10.2 Profile 2

Profile 3

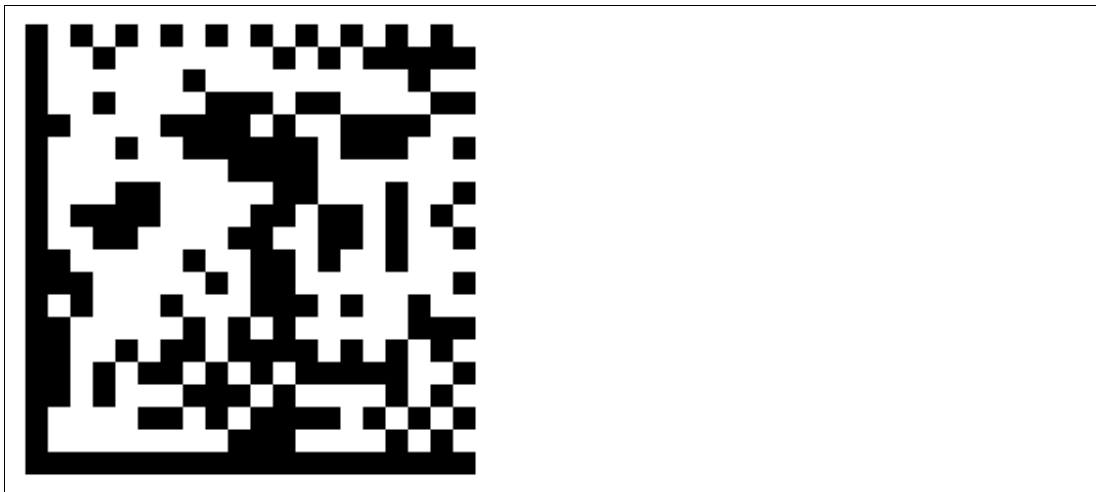

Figure 10.3 Profile 3

Profile 4

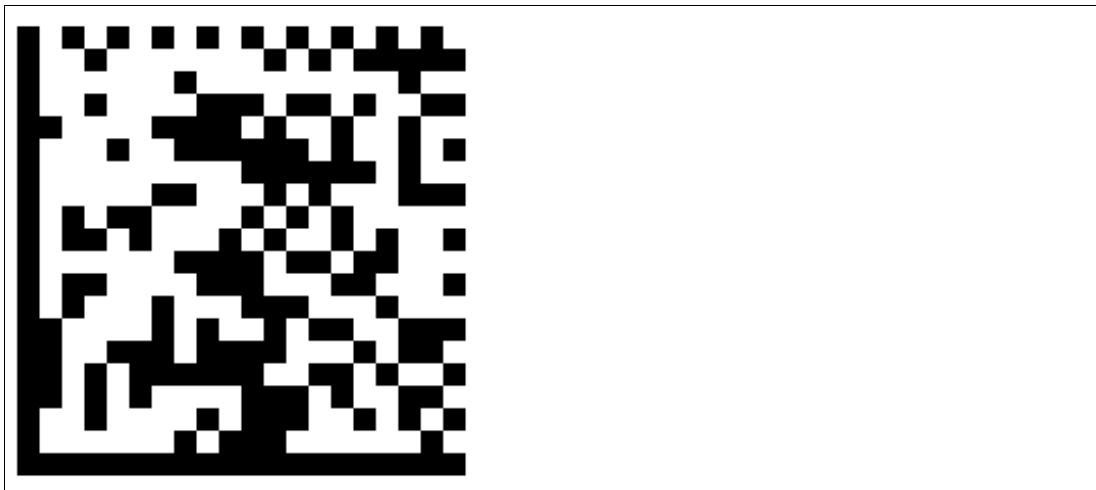

Figure 10.4 Profile 4

Profile 5

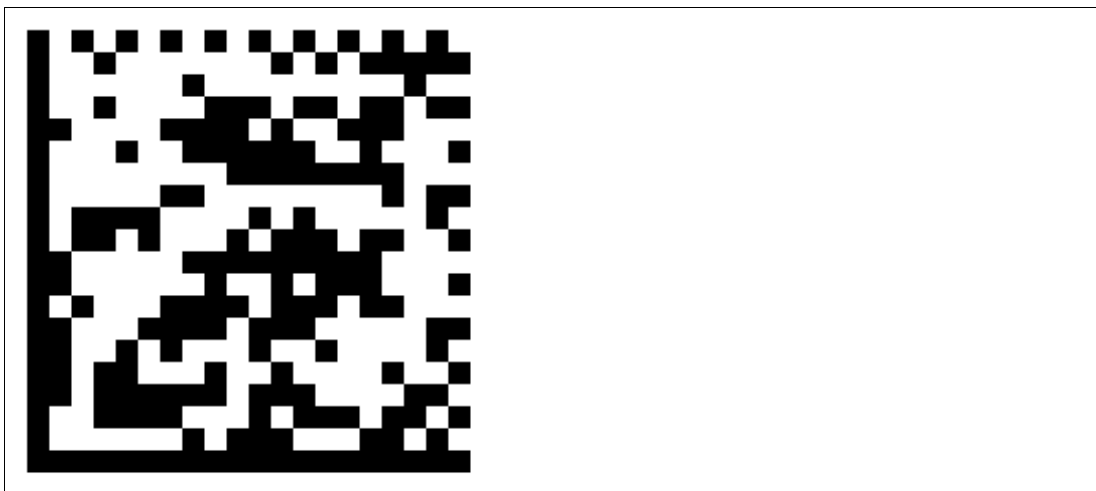

Figure 10.5 Profile 5

Profile 6

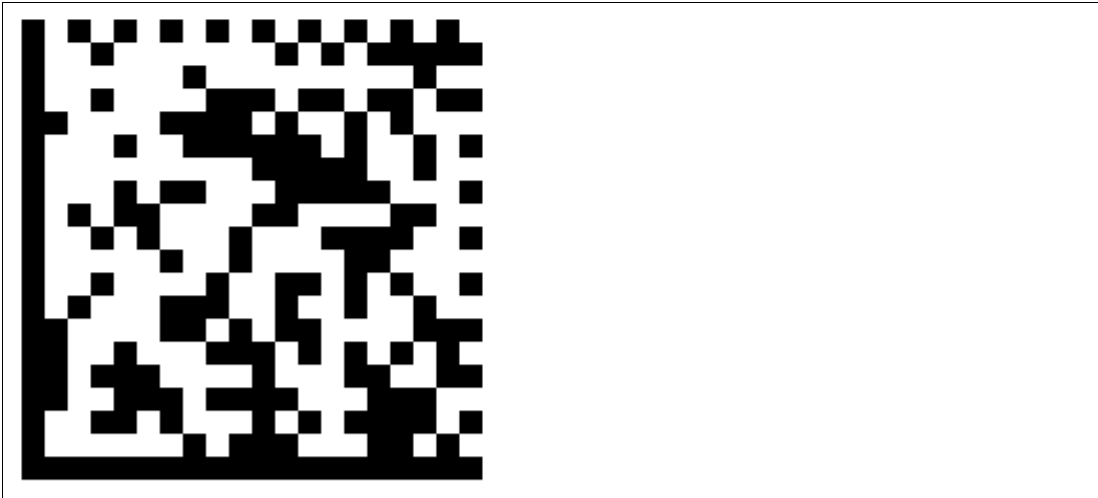

Figure 10.6 Profile 6

Profile 7

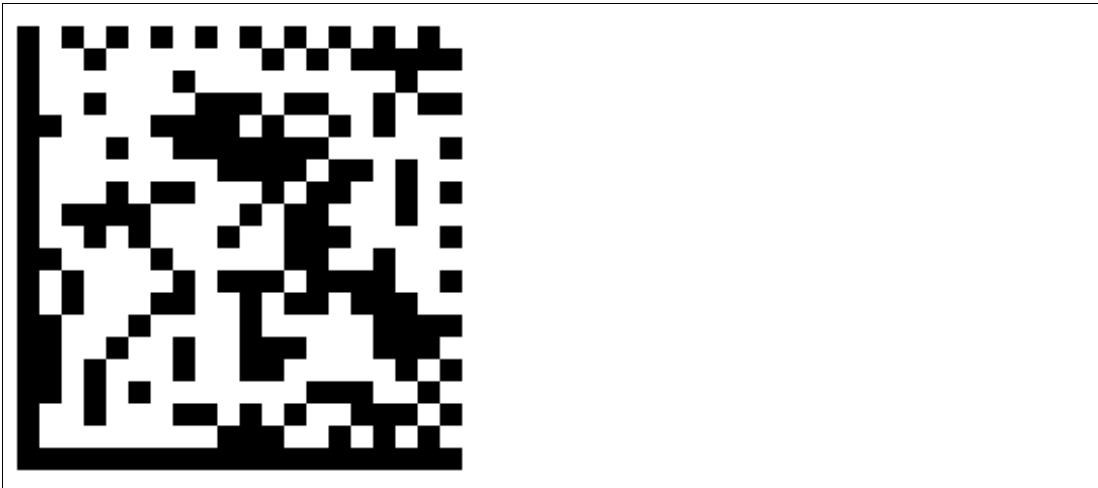

Figure 10.7 Profile 7

Profile 8

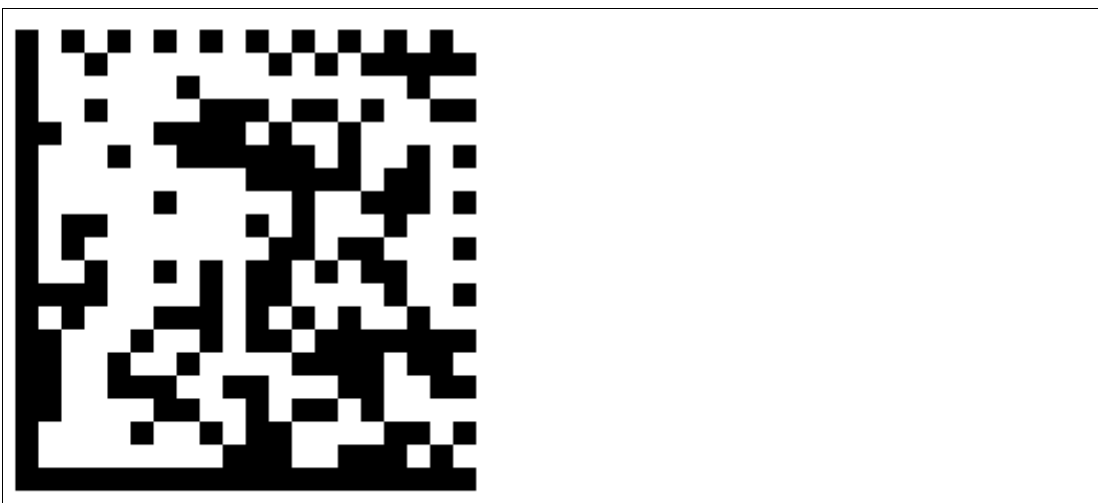

Figure 10.8 Profile 8

Profile 9

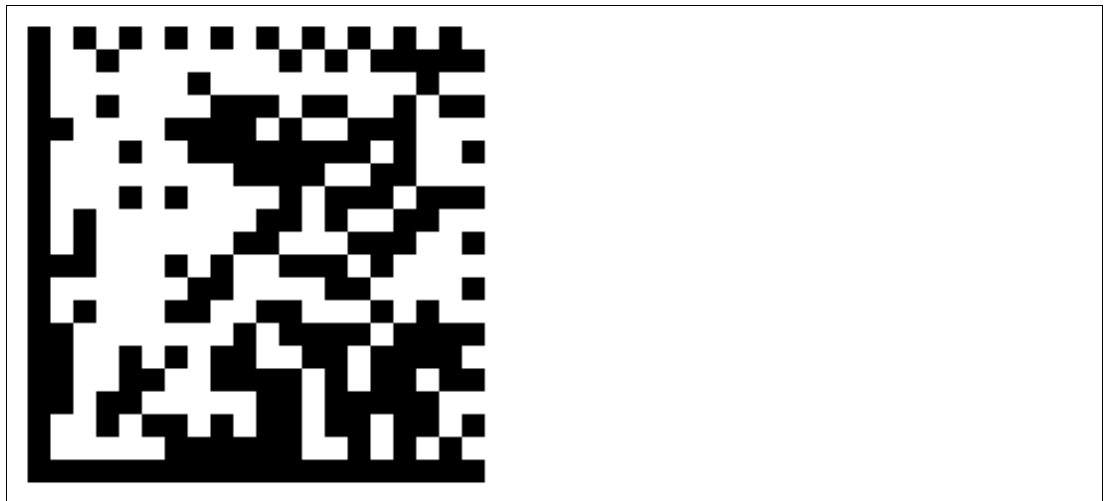

Figure 10.9 Profile 9

Profile 10

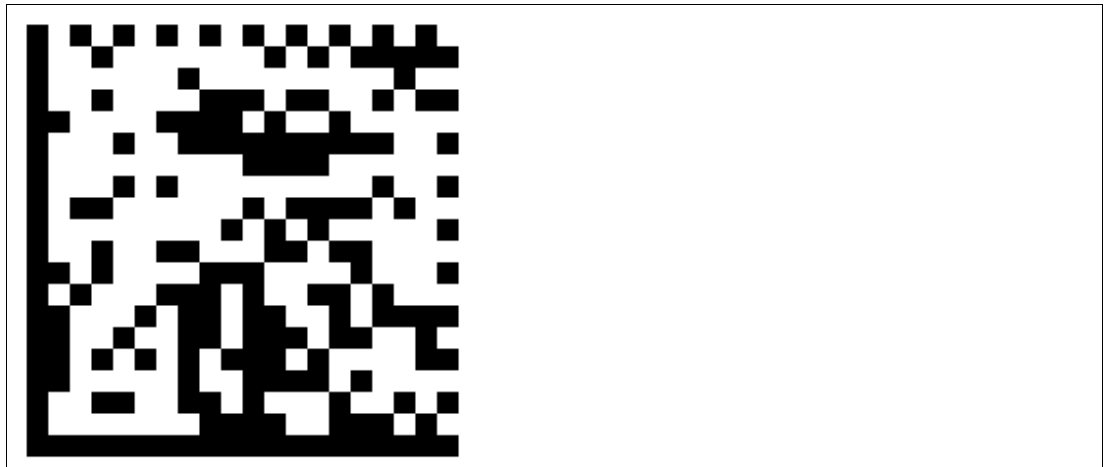

Figure 10.10 Profile 10

Profile 11

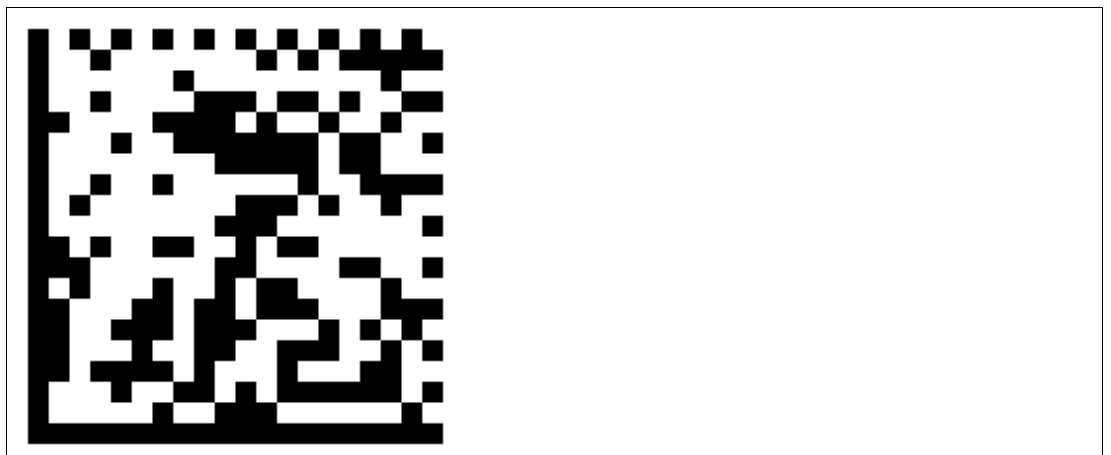

Figure 10.11 Profile 11

Profile 12

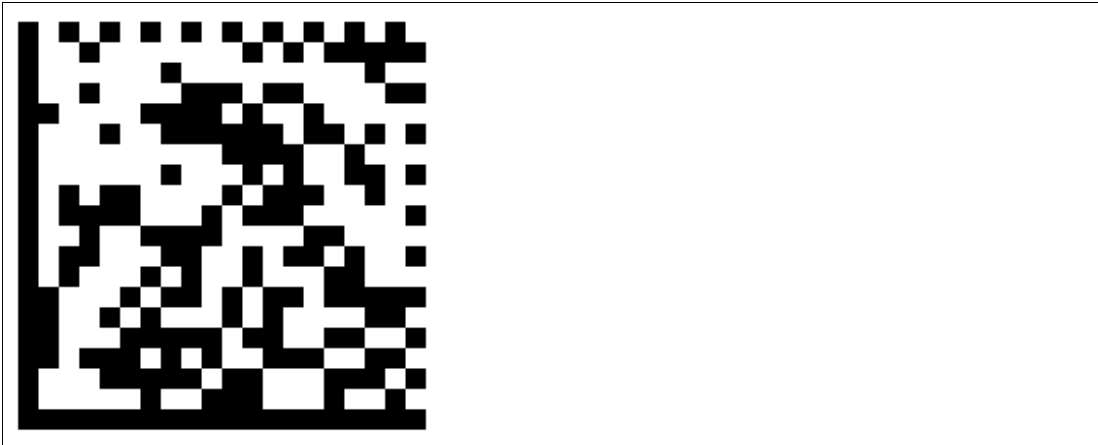

Figure 10.12 Profile 12

Profile 13

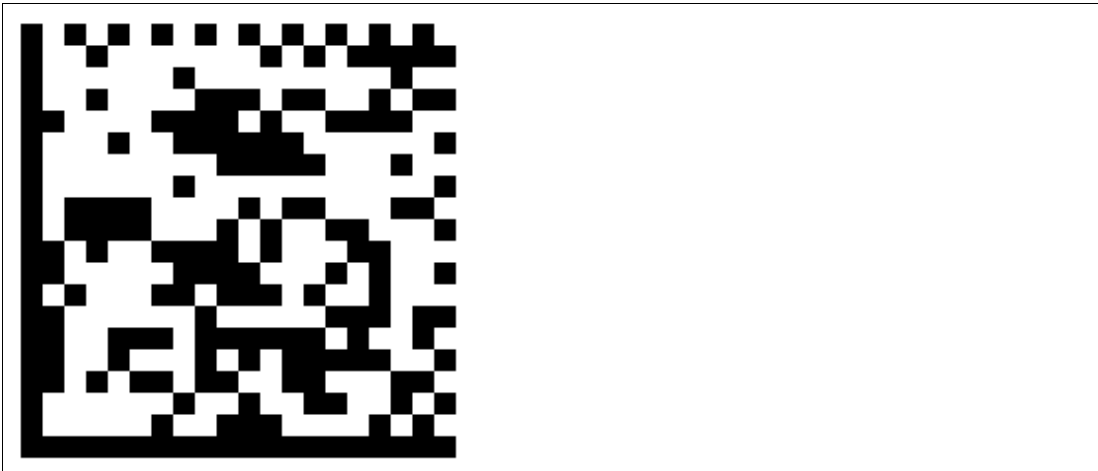

Figure 10.13 Profile 13

Profile 14

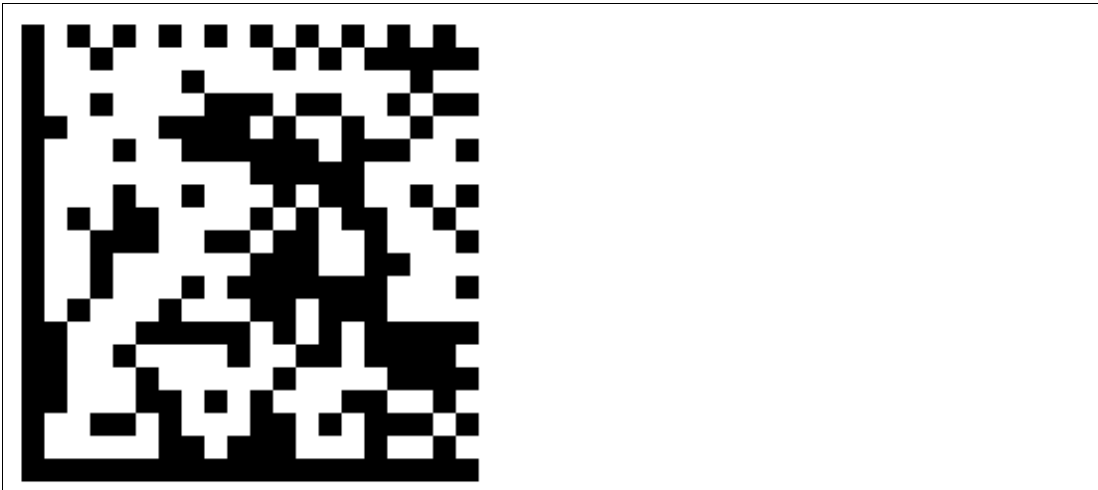

Figure 10.14 Profile 14

Profile 15

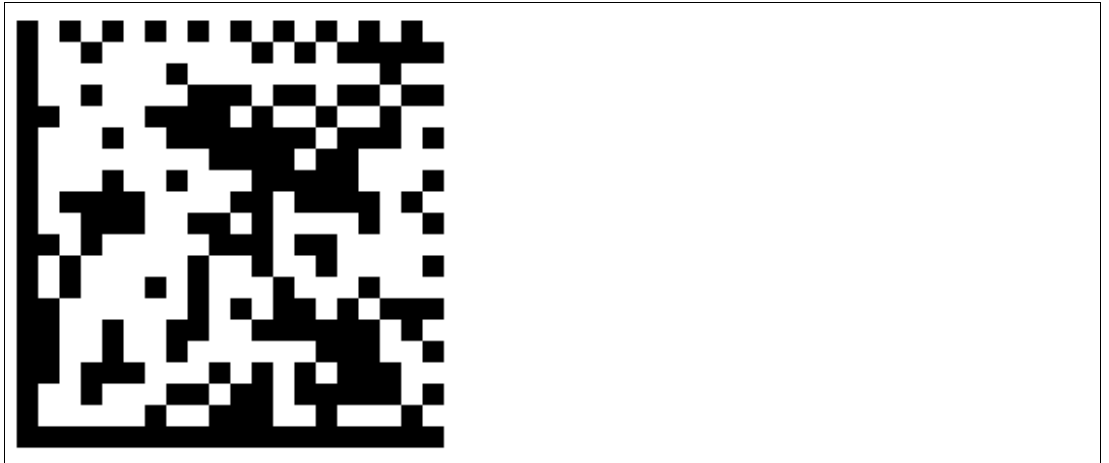

Figure 10.15 Profile 15

Profile 16

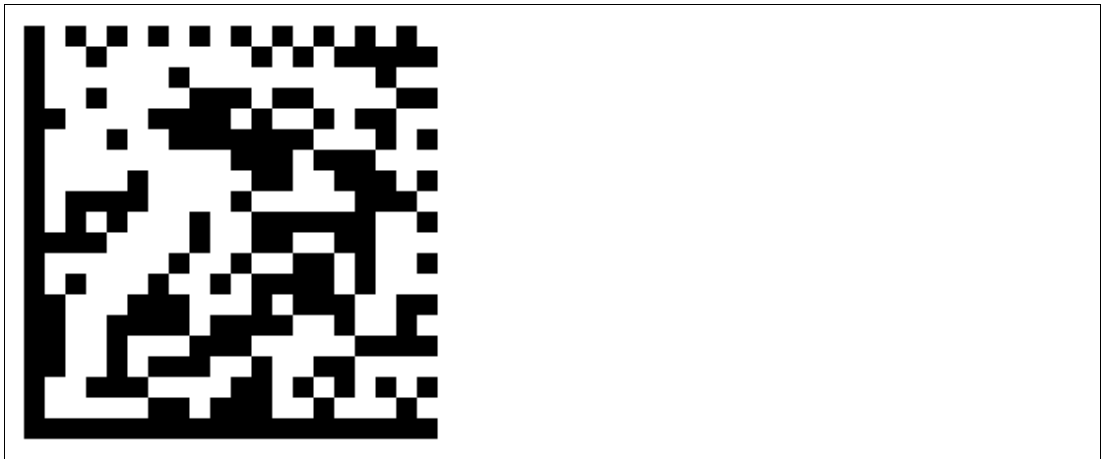

Figure 10.16 Profile 16

Profile 17

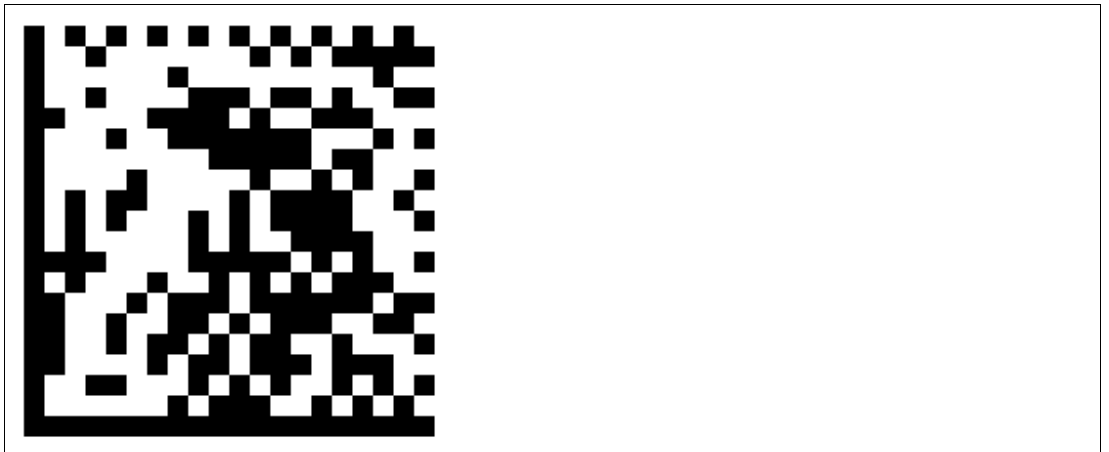

Figure 10.17 Profile 17

Profile 18

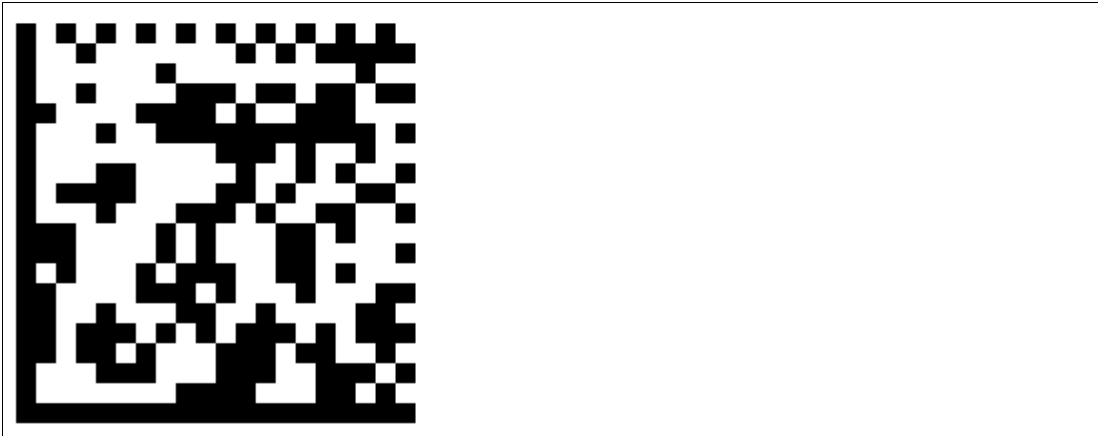

Figure 10.18 Profile 18

Profile 19

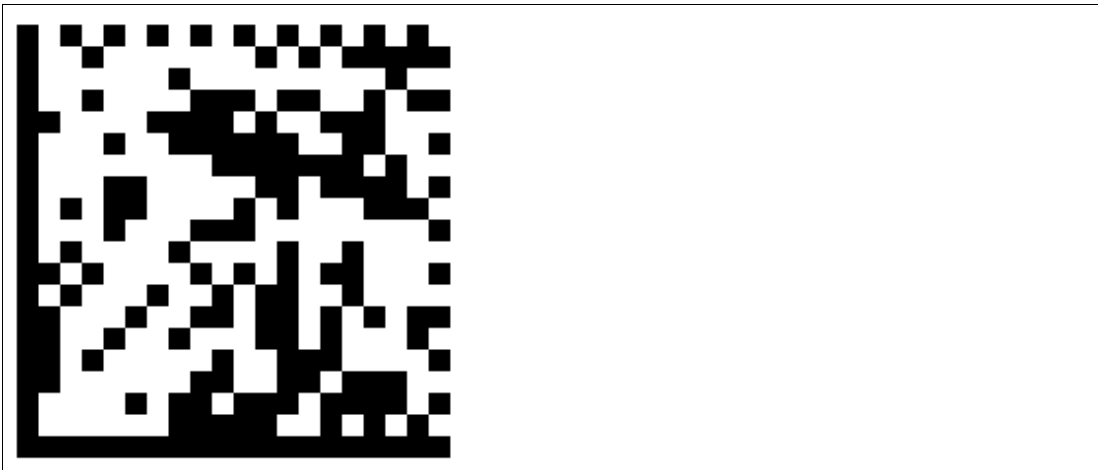

Figure 10.19 Profile 19

Profile 20

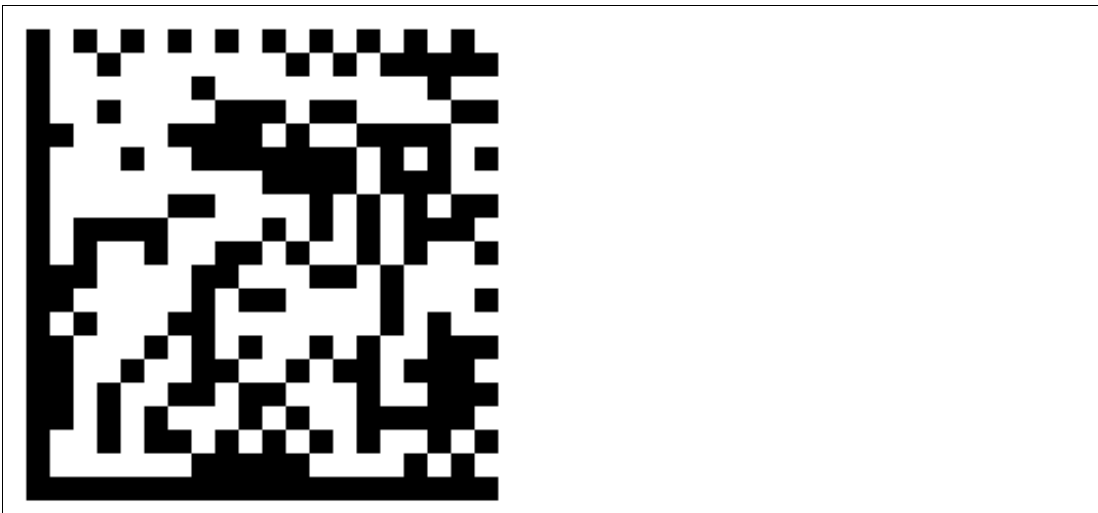

Figure 10.20 Profile 20

Profile 21

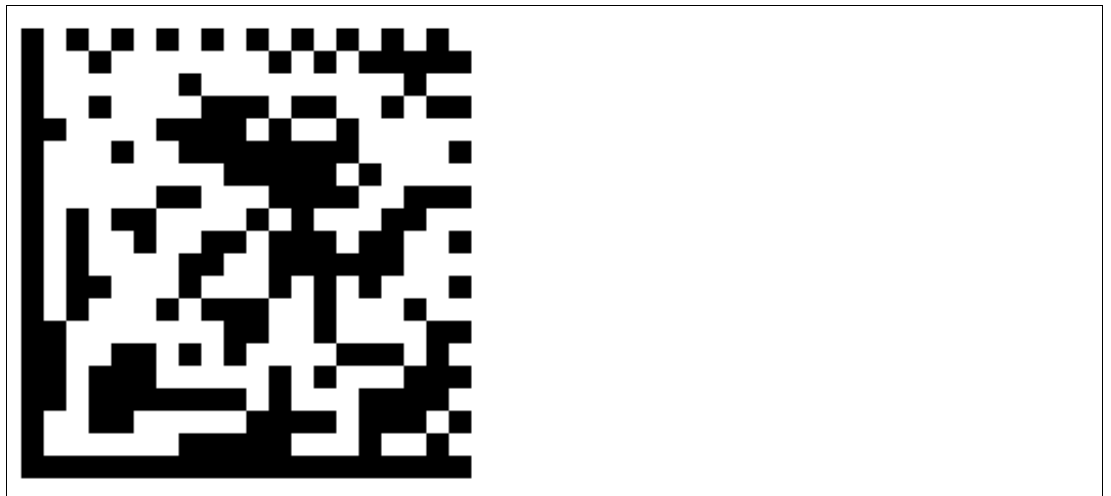

Figure 10.21 Profile 21

Profile 22

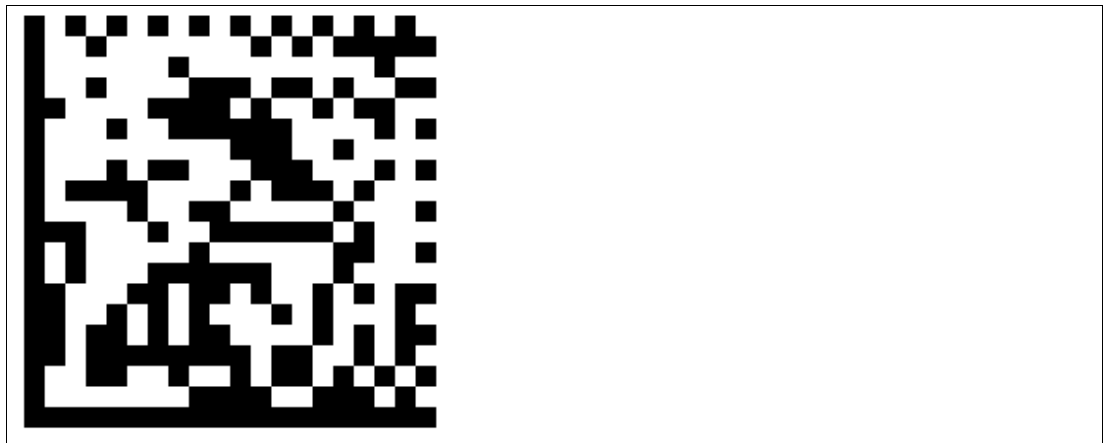

Figure 10.22 Profile 22

Profile 23

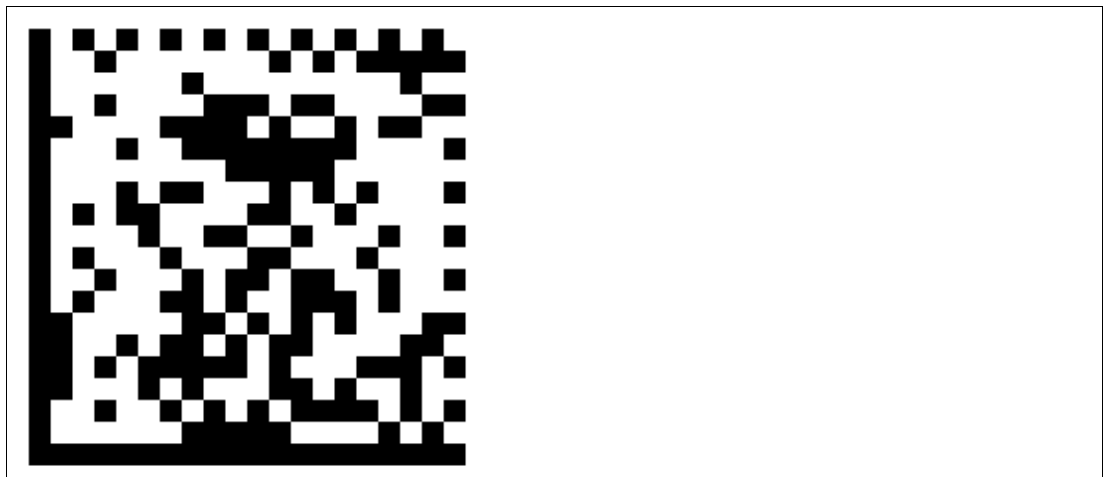

Figure 10.23 Profile 23

Profile 24

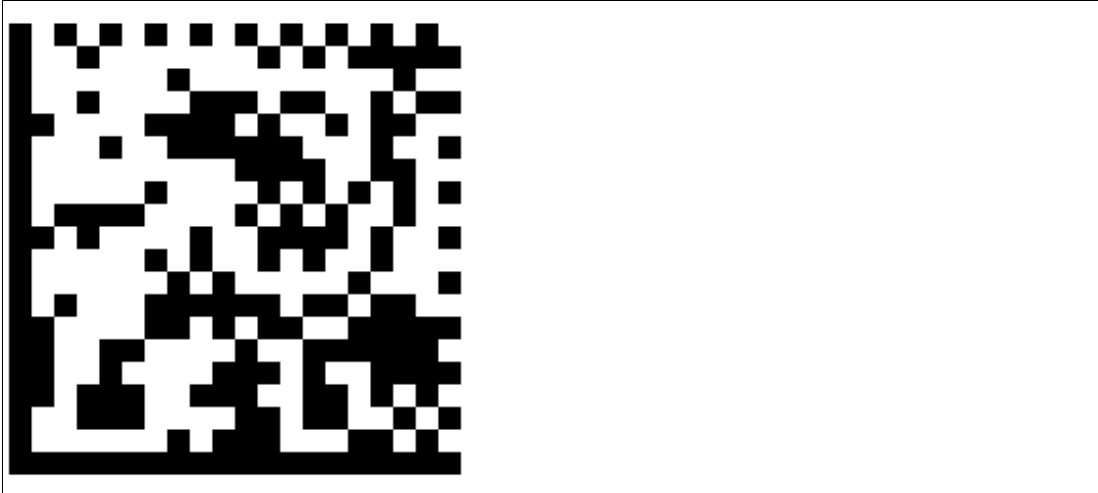

Figure 10.24 Profile 24

Profile 25

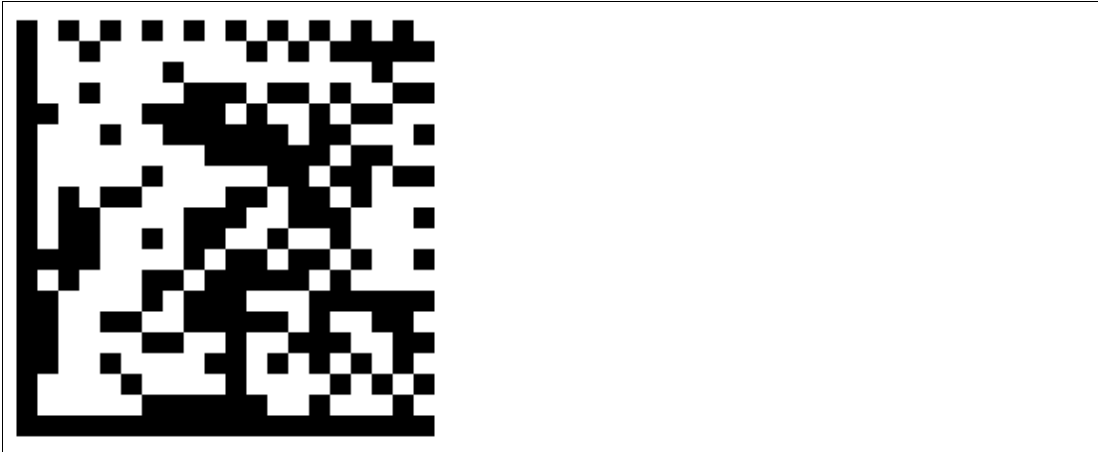

Figure 10.25 Profile 25

Profile 26

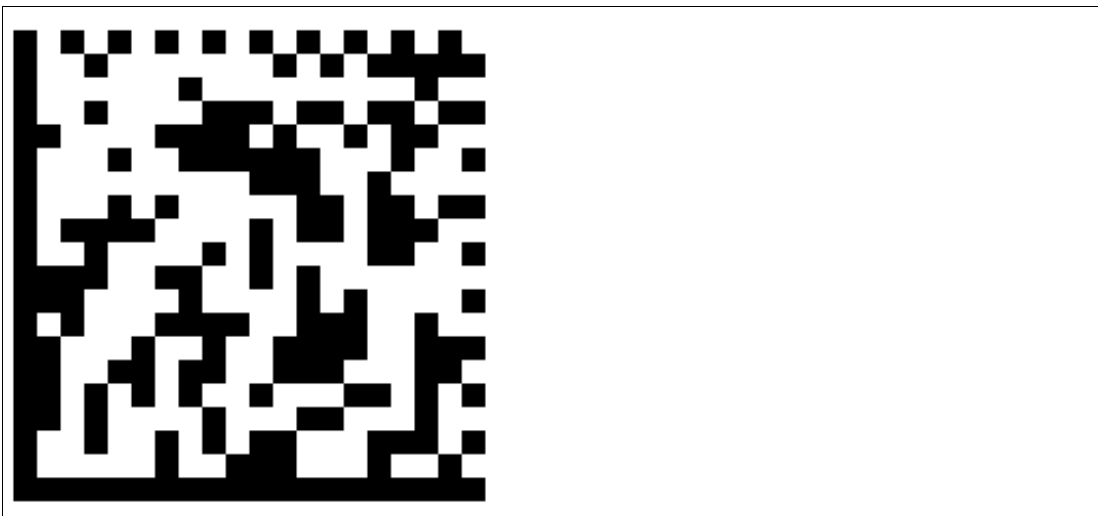

Figure 10.26 Profile 26

Profile 27

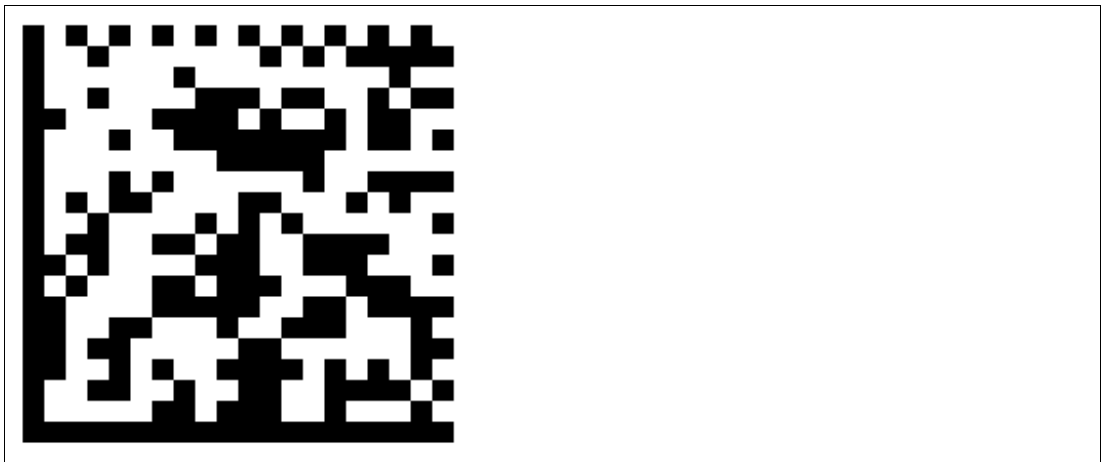

Figure 10.27 Profile 27

Profile 28

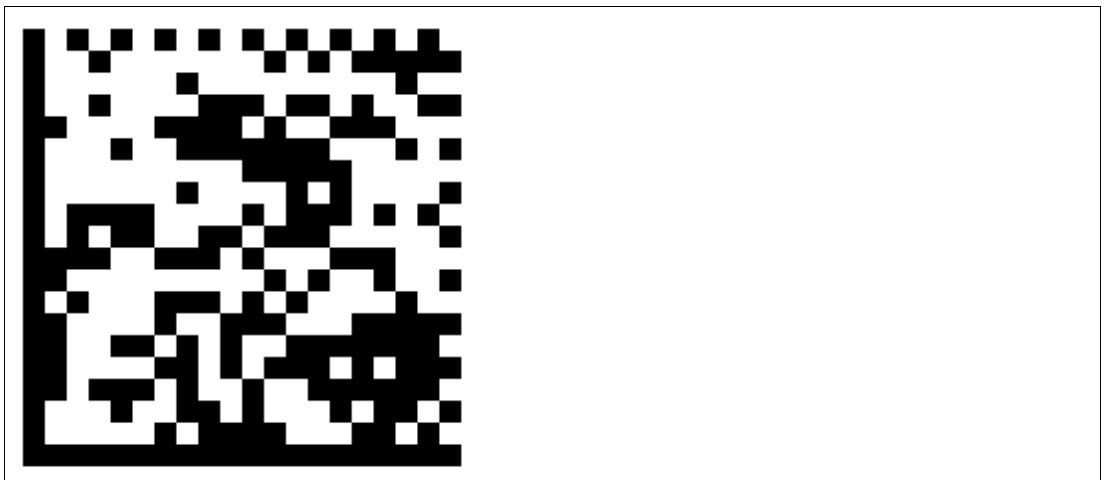

Figure 10.28 Profile 28

Profile 29

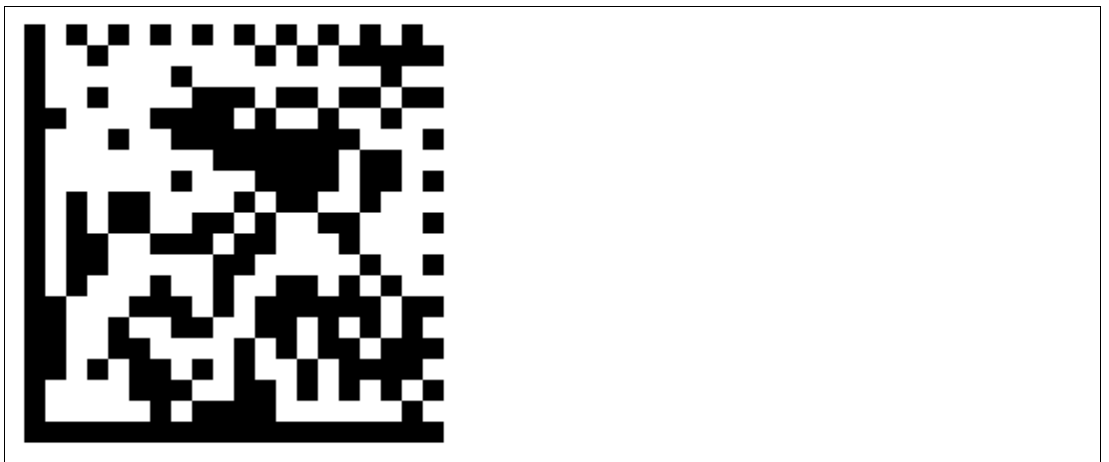

Figure 10.29 Profile 29

Profile 30

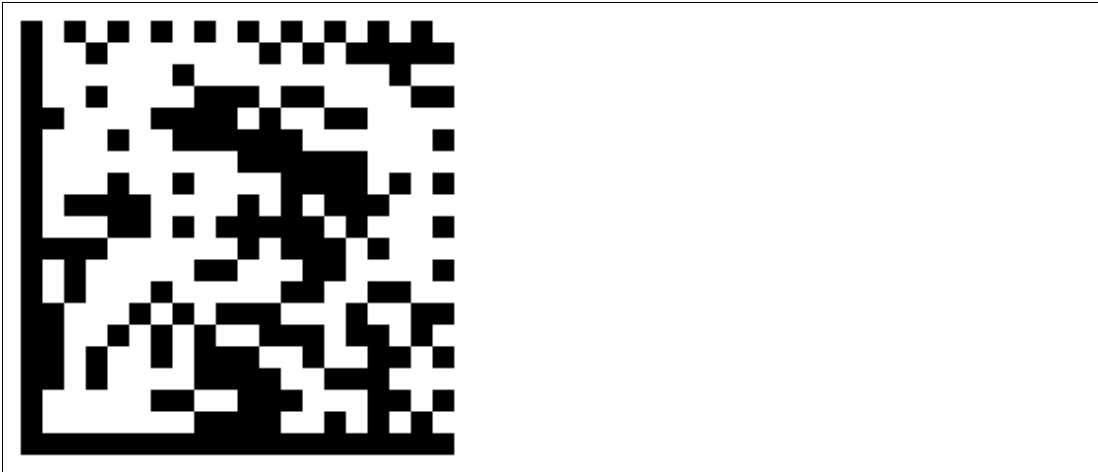

Figure 10.30 Profile 30

Profile 31

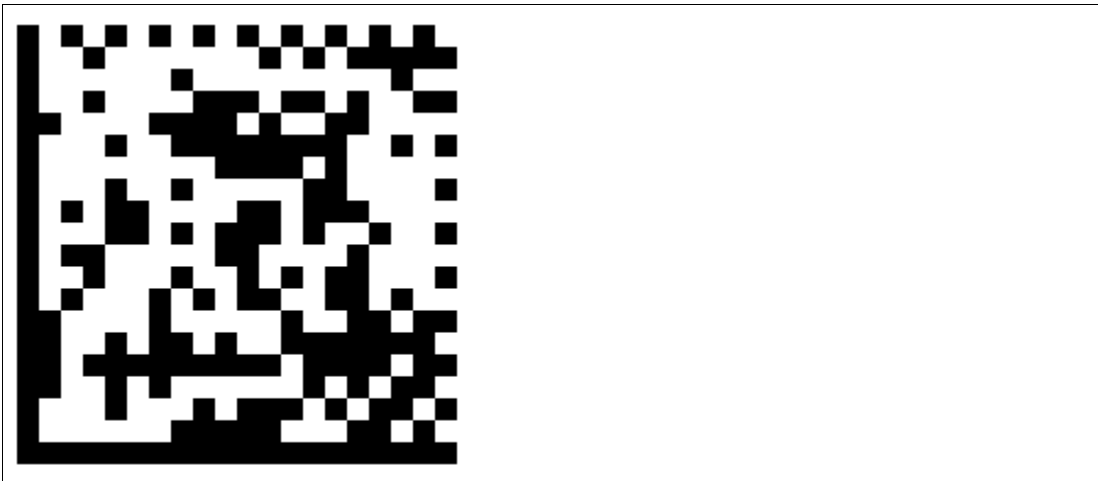

Figure 10.31 Profile 31

Profile 32

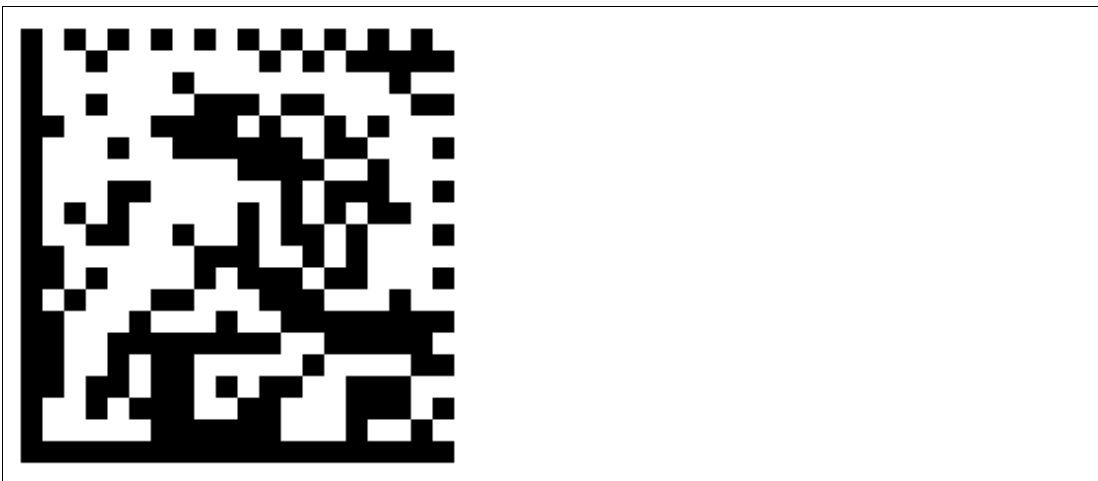

Figure 10.32 Profile 32

Your automation, our passion.

Explosion Protection

- Intrinsic Safety Barriers
- Signal Conditioners
- FieldConnex® Fieldbus
- Remote I/O Systems
- Electrical Ex Equipment
- Purge and Pressurization
- Industrial HMI
- Mobile Computing and Communications
- HART Interface Solutions
- Surge Protection
- Wireless Solutions
- Level Measurement

Industrial Sensors

- Proximity Sensors
- Photoelectric Sensors
- Industrial Vision
- Ultrasonic Sensors
- Rotary Encoders
- Positioning Systems
- Inclination and Acceleration Sensors
- Fieldbus Modules
- AS-Interface
- Identification Systems
- Displays and Signal Processing
- Connectivity

Pepperl+Fuchs Quality

Download our latest policy here:

www.pepperl-fuchs.com/quality

