

MANUAL

WCS-CG310

WCS CANopen Interface Module



With regard to the supply of products, the current issue of the following document is applicable: The General Terms of Delivery for Products and Services of the Electrical Industry, published by the Central Association of the Electrical Industry (Zentralverband Elektrotechnik und Elektroindustrie (ZVEI) e.V.) in its most recent version as well as the supplementary clause: "Expanded reservation of proprietorship"

1	Introduction.....	4
1.1	Content of this Document	4
1.2	Target Group, Personnel.....	4
1.3	Symbols Used	4
2	Product Description	6
2.1	Use and Application.....	6
2.2	Dimensions.....	6
2.3	Design of the Device.....	7
3	Installation.....	13
3.1	Mounting.....	13
3.2	Electrical Connection	14
3.3	Dismounting	16
4	Operation.....	18
4.1	Data Exchange in the CANopen® Bus	18
5	Appendix	21
5.1	Cable Routing in the RS-485 Bus	21
5.2	Data Cables and Accessories	24



1 Introduction

1.1 Content of this Document

This document contains information required to use the product in the relevant phases of the product life cycle. This may include information on the following:

- Product identification
- Delivery, transport, and storage
- Mounting and installation
- Commissioning and operation
- Maintenance and repair
- Troubleshooting
- Dismounting
- Disposal



Note!

For full information on the product, refer to the further documentation on the Internet at www.pepperl-fuchs.com.

The documentation comprises the following parts:

- This document
- Datasheet

In addition, the documentation may comprise the following parts, if applicable:

- EU-type examination certificate
- EU declaration of conformity
- Attestation of conformity
- Certificates
- Control drawings
- Instruction manual
- Other documents

1.2 Target Group, Personnel

Responsibility for planning, assembly, commissioning, operation, maintenance, and dismounting lies with the plant operator.

Only appropriately trained and qualified personnel may carry out mounting, installation, commissioning, operation, maintenance, and dismounting of the product. The personnel must have read and understood the instruction manual and the further documentation.

Prior to using the product make yourself familiar with it. Read the document carefully.

1.3 Symbols Used

This document contains symbols for the identification of warning messages and of informative messages.

Warning Messages

You will find warning messages, whenever dangers may arise from your actions. It is mandatory that you observe these warning messages for your personal safety and in order to avoid property damage.

Depending on the risk level, the warning messages are displayed in descending order as follows:



Danger!

This symbol indicates an imminent danger.

Non-observance will result in personal injury or death.



Warning!

This symbol indicates a possible fault or danger.

Non-observance may cause personal injury or serious property damage.



Caution!

This symbol indicates a possible fault.

Non-observance could interrupt the device and any connected systems and plants, or result in their complete failure.

Informative Symbols



Note!

This symbol brings important information to your attention.



Action

This symbol indicates a paragraph with instructions. You are prompted to perform an action or a sequence of actions.

2 Product Description

2.1 Use and Application

The WCS-CG310 is used as an interface between the WCS reader and the CAN bus. The data is transferred between the WCS reader(s) and the WCS-CG310 via the RS-485 interface, and from the WCS-CG310 to the control panel via the CANopen protocol.

You can connect up to 4 WCS readers of type LS221 or LS121. If you connect several readers, they must have different addresses. The interface module WCS-CG310 acts as a CANopen slave in the "Predefined Connection Set" and allows data transfer rates of up to 1 MBaud.

2.2 Dimensions

The interface module housing has the following dimensions.

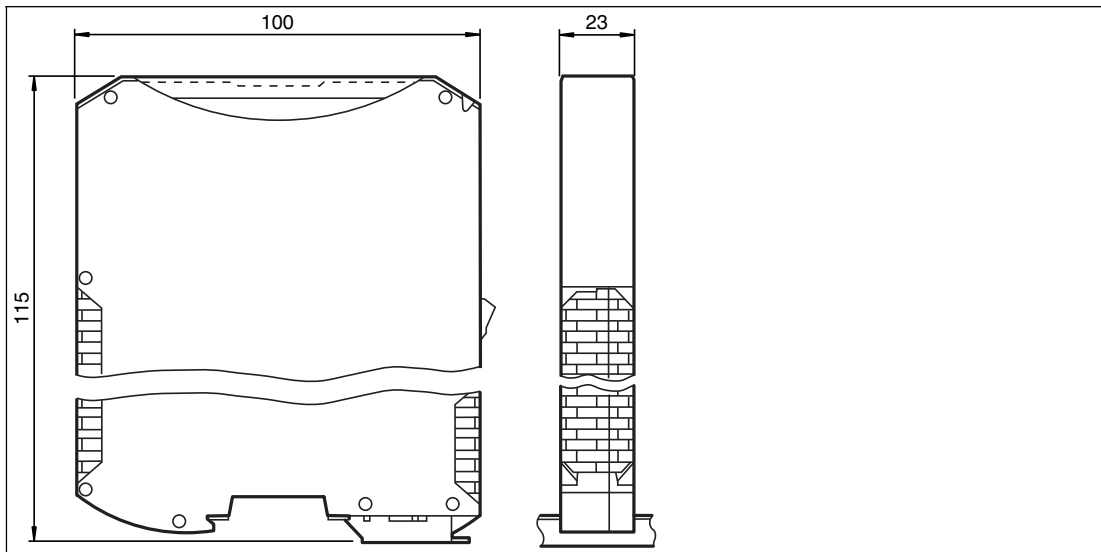

Figure 2.1 Dimensions

2.3 Design of the Device

Device Components

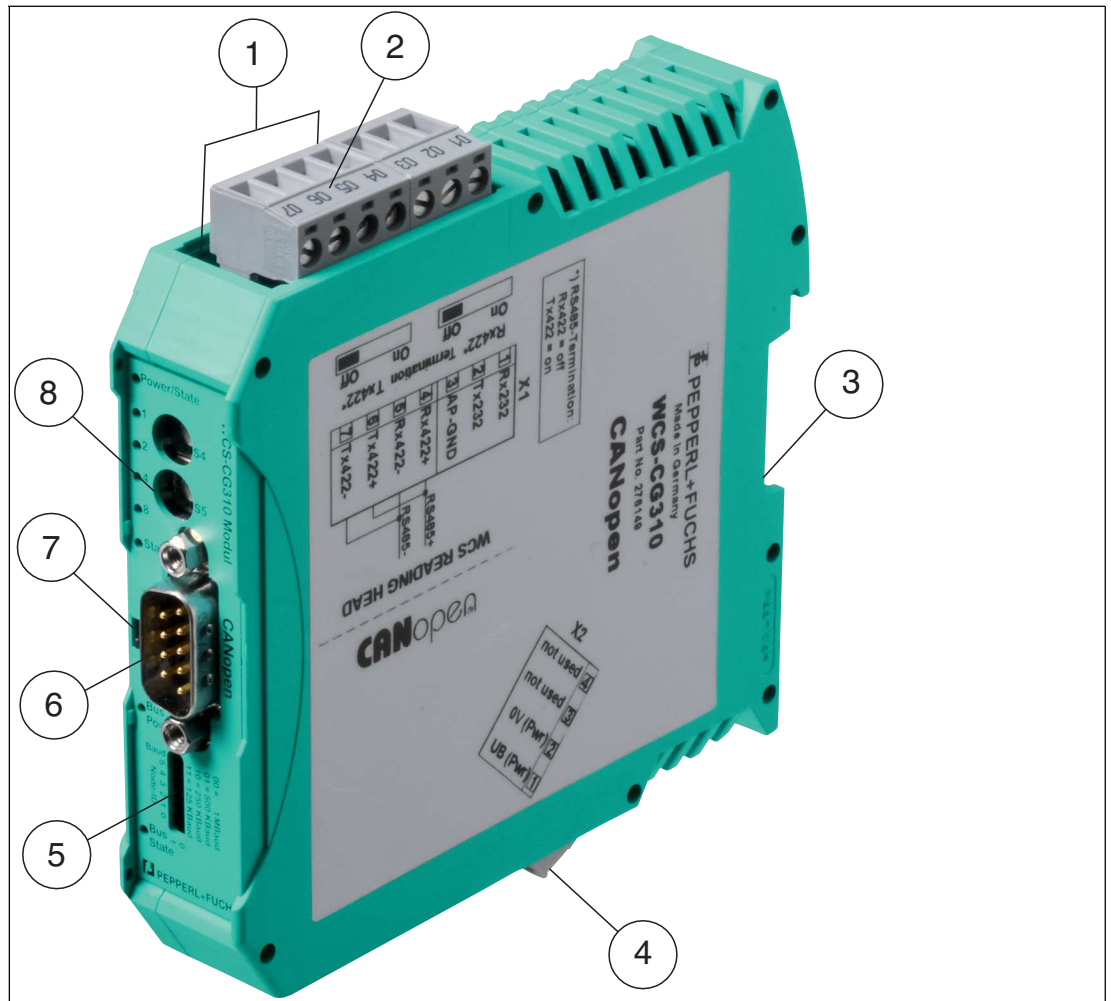

Figure 2.2 Interface module overview

- 1 RS-485 terminator sliding switch (behind the terminal block)
- 2 X1: RS-485 interface
- 3 Mounting bracket
- 4 X2: Connection for power supply
- 5 DIP switch
- 6 CANopen communication interface
- 7 CANopen terminator sliding switch
- 8 Front panel with rotary coding switches and indicator lights

Front Panel

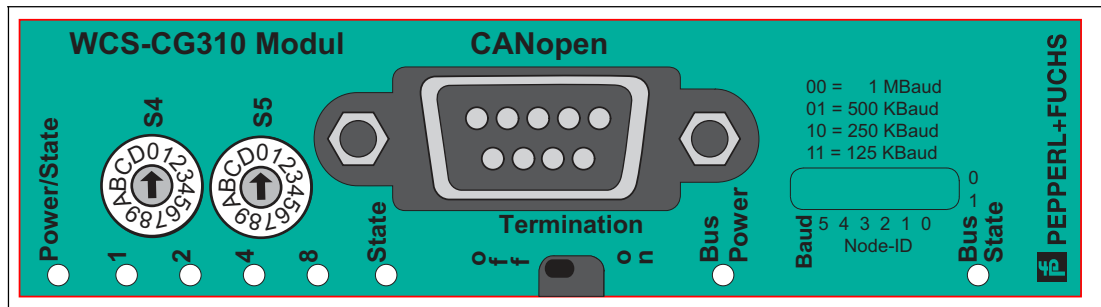

Figure 2.3 Front panel overview

Power:

The "Power" LED lights up green:
The WCS-CG310 interface module is correctly connected to the power supply.

State:

The "State" LED lights up green:
Data is being exchanged with the WCS reader. The four "Error No/Select ID" LEDs are used to display the number of the currently polled WCS reader.

Error No/Select ID				Reader address
8	4	2	1	
0	0	0	1	0
0	0	1	0	1
0	1	0	0	2
1	0	0	0	3

The "State" LED lights up red:
The interface module has detected a fault or a warning. The interface module displays the binary coded error and/or warning number via the "Error No/Select ID" LEDs.

- Error (No. 1...5): Switch the interface module off and back on. If the error occurs again, the module must be replaced.
- Warning (No. 6...15): These warnings are for information only, are displayed for 1 minute, and are then automatically reset. If these warnings occur more frequently, notify customer service.

LED Error No/Select ID				Error number	Error description
LED8	LED4	LED2	LED1		
0	0	0	0	0	Reserved
0	0	0	1	1	Hardware error
0	0	1	0	2	EEPROM error
0	0	1	1	3	Internal memory error
0	1	0	0	4	Fieldbus hardware error or incorrect fieldbus ID
0	1	0	1	5	Script error
0	1	1	0	6	Reserved
0	1	1	1	7	Send buffer overflow
1	0	0	0	8	Receive buffer overflow
1	0	0	1	9	Timeout when receiving reader data Cause: faulty cabling, baud rate on the reader, reader address
1	0	1	0	10	General fieldbus error
1	0	1	1	11	Parity error or frame check error
1	1	0	0	12	Reserved
1	1	0	1	13	Fieldbus configuration error
1	1	1	0	14	Fieldbus data buffer overflow
1	1	1	1	15	Reserved

Table 2.1 Meaning of the error codes (display via the four "Error No/Select ID" LEDs when the "State" LED lights up red and thus indicates an error or a warning)

Rotary Coding Switch S4—Transmitting Mode

Set the number of connected readers with the rotary switch S4 in accordance with the table "Rotary Switch S4." When you set this switch, the baud rate range is simultaneously set to the default value.

Switch position S4	Number of readers	Addresses	Baud rate range
1	1 reader	Address 0	BD set A
2	2 readers	Address 0, 1	BD set A
3	3 readers	Address 0, 1, 2	BD set A
4	4 readers	Address 0, 1, 2, 3	BD set A
5	1 reader	Address 0	BD set B
6	2 readers	Address 0, 1	BD set B
7	3 readers	Address 0, 1, 2	BD set B
8	4 readers	Address 0, 1, 2, 3	BD set B

DIP Switch—Baud Rate Range

If you have set the baud rate range to the default value via the rotary switch S4, you can use DIP switches 6 and 7 to set the baud rate. See the following table:

DIP switch		BD set A	BD set B
7	6		
0	0	1 MBaud	100 kBaud
0	1	500 kBaud	50 kBaud
1	0	250 kBaud	20 kBaud
1	1	125 kBaud	10 kBaud

Rotary Coding Switch S5

You can configure the "Transmission Type" in the WCS-CG310 in accordance with the CANopen® specification. When the power is switched on, the following "Transmission Type" is pre-configured in the WCS-CG310:

S5 = 0...B, E, and F: asynchronous

In asynchronous transmission, the WCS-CG310 sends automatically if there is a change in the reader data, but not more than every 3...250 ms (configurable via rotary switch S5, see the following table). This prevents an overload of the CANopen bus if there are continuous changes in the WCS data. If the position value does not change (vehicle is stationary), with asynchronous transfer no further data is sent. When the switch is set to position E/F, the position value is sent at most every 5 ms/3 ms, but at least every 50 ms/20 ms. Thus the control panel receives data even if the vehicle is stationary.

S5 = D: cyclically synchronous

The WCS-CG310 transmits data after the SYNC command. If one or two WCS readers are connected, PDO1 is sent. If more than two WCS readers are connected, PDO1 and PDO2 are sent. The typical delay time after SYNC is 2 ms; the maximum delay time is 5 ms.

S5	Min. pause time
0	3 ms
1	5 ms
2	10 ms
3	15 ms
4	20 ms
5	30 ms
6	40 ms
7	50 ms
8	100 ms
9	150 ms
A	200 ms
B	250 ms
C	res.
D	Sync mode
E	5 ms/50 ms
F	3 ms/20 ms

Table 2.2 Switch position of rotary switch S5

Bus Power:

The "Power" LED lights up green: The LED is connected directly to the electrically isolated supply voltage of the CANopen side.

CANopen Terminator

If the interface module is operated as the first or last physical device in CANopen®, there must be a bus termination on this interface module. To do this, activate either a bus terminator in the plug or the resistor integrated into the interface module (220 Ω). To do this, set the "Termination" sliding switch to "On." This activates the CANopen terminator integrated into the interface module. In all other cases, the sliding switch remains in the "Off" position.

More information about bus termination can be found in the general fieldbus literature.



Note!

To activate or deactivate the bus terminator, please remove the bus plug and carefully move the switch to the desired position.

Bus State:

The following indicator states and flashing frequencies may occur:

Indicator States and Flashing Frequencies

LED on	On constantly
LED off	Off constantly
LED flickering	ISO phase on and off at a frequency of approx. 10 Hz: on for approx. 50 ms and off for approx. 50 ms.
LED flashing	ISO phase on and off at a frequency of approx. 2.5 Hz: on for approx. 200 ms, then off for approx. 200 ms.
LED single flash	Short flash (about 200 ms), followed by a long off phase (about 1000 ms).
LED double flash	A sequence of two short flashes (approx. 200 ms), separated by an off phase (approx. 200 ms). The sequence ends with a long off phase (approx. 1000 ms).
LED triple flash	A sequence of three short flashes (approx. 200 ms), separated by an off phase (approx. 200 ms). The sequence ends with a long off phase (approx. 1000 ms).

Instead of two single color LEDs, a two-color status LED is used, which displays both the physical BUS status and the CANopen machine status. This two-color LED is red and green.

The **CANopen fault LED** indicates the state of the physical CAN layer and faults on the basis of missing CAN messages (SYNC, GUARD or HEARTBEAT):

CANopen Fault LED (Red):

Fault indicator	State	Description
Off	No error	The device is in operational state.
Single flash	Warning limit has been reached	At least one of the CAN controller error counters has reached or exceeded the warning limit (too many error frames).
Flickering	AutoBaud/LSS	Auto baud rate detection in process or LSS service in process (flickering alternately to the RUN LED)
Double flash	Error check event	A "guard" event (NMT slave or NMT master) or a heartbeat event (heartbeat "consumer") has occurred.
Triple flash	Sync error	The SYNC-communication was not received within the configured communication cycle off time (see object dictionary entry 0x1006).
On	Bus off	The CAN controller is "Bus off."

If several errors have occurred at a given time, the error with the highest number is indicated. For example, if an NMT and a SYNC error occur, the SYNC error is indicated.

The **CANopen RUN LED** indicates the CANopen network machine status:

CANopen RUN LED (Green):

CAN RUN LED	State	Description
Flickering	AutoBaud/LSS	Auto baud rate detection in process or LSS service in process (flickering alternately to the fault indicator)
Single flash	Stopped	The device is in the stop state.
Flashing	PREOPERATIONAL	The device is in the "PREOPERATIONAL" state.
On	OPERATIONAL	The device is in the "OPERATIONAL" state.

While the device restarts, the CANopen RUN LED should be off.

If an event occurs that triggers the red and green states simultaneously, the LED will change to red. In all other cases, the two-color Status LED should combine the behavior of the CAN fault LED and the CAN RUN LED.

RS-485 Terminator

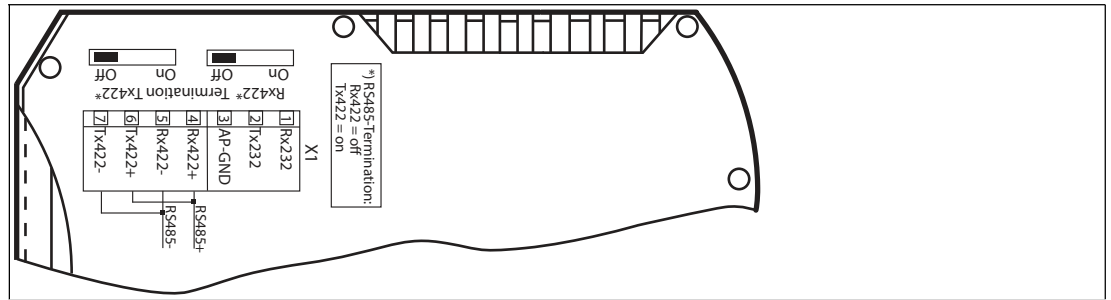

If the interface module is operated as the first or last physical device in an RS-485 bus, there must be a bus termination on this module. To do this, set the "Rx 422 Termination" slide switch to "Off" and the "Tx 422 Termination" slide switch to "On." This activates the RS-485 terminator (150 Ω) built into the interface module.

If you only connect one WCS reader to the interface module, you must always activate the RS-485 terminator; see also Cable routing in the RS-485 bus.

3 Installation

3.1 Mounting



Mounting the Modules

The module is fastened to a DIN mounting rail with a width of 35 mm using a snap-on fixing method.

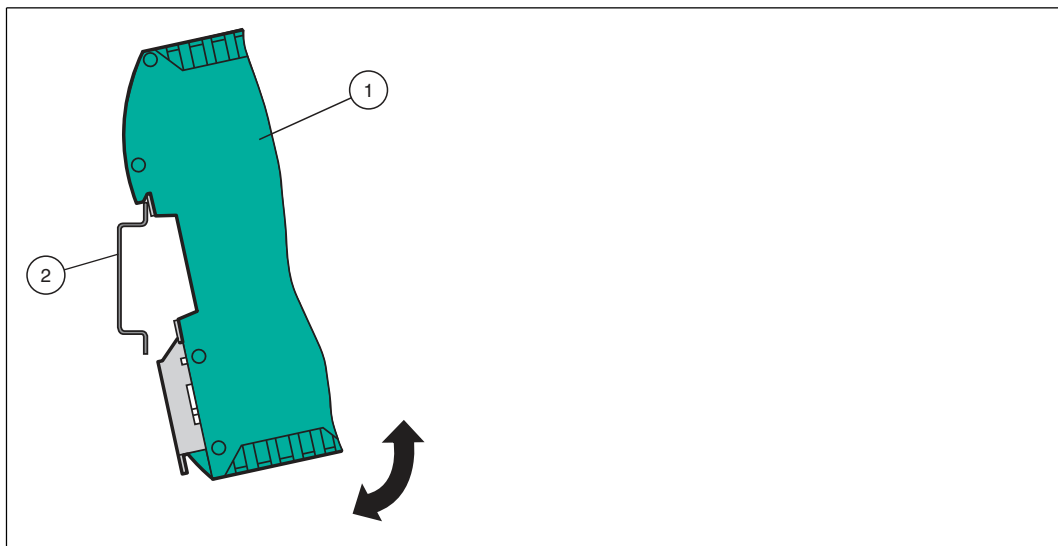

Figure 3.1 Mounting

1. Hook the module (1) onto the DIN mounting rail (2) from above and press it down until it snaps into place.

↳ The module is mounted.



Note!

Heat Dissipation

You may place other modules to the left and right of the module. Above and below the modules, there must be at least 5 cm of free space for heat dissipation.

2. You must connect the DIN mounting rail to the switch cabinet's equipotential busbar. The connection wire must have a cross section of at least 10 mm².



Note!

Vertical Installation

You can also install the DIN mounting rail vertically, so that the modules can be rotated by 90° for mounting.

3.2 Electrical Connection



Danger!

Device damage due to incorrect installation

Incorrect installation of cables and connection lines can endanger the function and the electrical safety of the device.

- Note the permissible core cross section of the conductor.
- If you are using stranded conductors, crimp the stranded conductors with wire end ferrules.
- Make sure that the insulation on the conductors extends all the way to the terminal.
- Observe the tightening torque for the screws on the terminal. The tightening torque is 0.5 Nm.
- Using an inappropriate tool may damage the screw heads. Use a slot-head screwdriver of size 3.5 x 0.5.
- Connecting an alternating current can damage the device or cause the device to malfunction. Connect the device to direct current (DC).

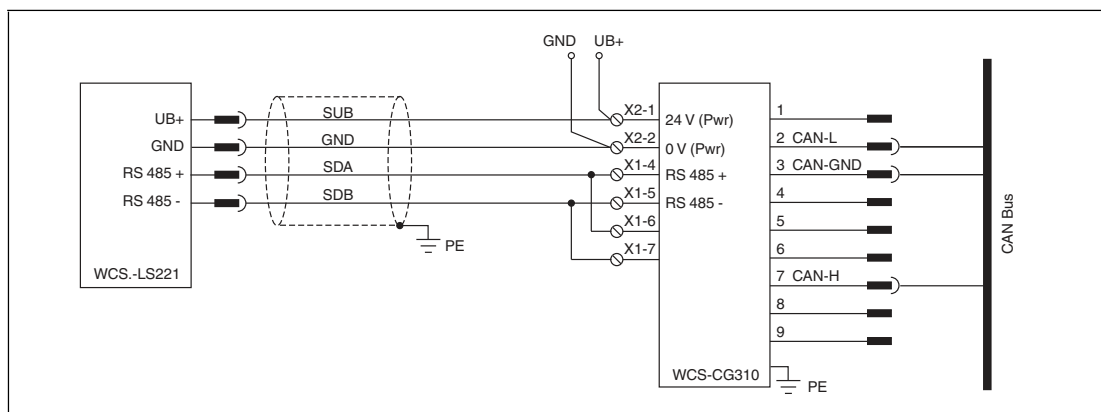

Figure 3.2 Electrical connection

Plug X1 is located on the top side of the interface module, and plug X2 is located on the underside.

Connection Technology

You must/may use the following connection technology when wiring the module:

- Standard screw/plug connection (supply + RS)
- 9-pin D-SUB connector (CANopen connection)

When using standard screw terminals, one cable per connection point can be clamped. To tighten the screws, use a screwdriver with a blade width of 3.5 mm.

Permissible cable cross section:

- Flexible cable with wire end ferrule: $1 \times 0.25 \dots 1.5 \text{ mm}^2$
- Solid cable: $1 \times 0.25 \dots 1.5 \text{ mm}^2$

The plug-in terminal strip combines a standard screw connection and a plug connector. The plug connector is coded and therefore cannot be plugged in incorrectly.

The 9-pin D-SUB connector is secured with two screws with a "4-40 UNC" thread. To tighten the screws, use a screwdriver with a blade width of 3.5 mm. Observe the maximum tightening torque of 0.4 Nm.

▶ Connecting the Power Supply

Connect the operating voltage (10 VDC...30 VDC) to terminals 1 and 2 of the 4 pin plug X2 on the interface module. In addition, note the label on the module.

↳ The "Power" LED lights up green.

Terminal		Description
1	UB (Pwr)	Operating voltage for interface module/ operating voltage for WCS reader
2	0 V (Pwr)	Ground for interface module/ground for WCS reader
3	not used	Is not used
4	not used	Is not used

Table 3.1 Terminal X2

Equipotential Bonding Connection

The connection to equipotential bonding occurs automatically when attaching to the DIN mounting rail.

▶ CANopen® Communication Interface

This interface can be found on the front of the housing in the form of a 9-pin D-SUB socket.

1. Connect the CANopen® connector to the D-SUB socket labeled "CANopen."
2. Tighten the lock screws on the connector using a screwdriver.
3. If the module is at the beginning or at the end of the CANopen® cable, you must connect the bus terminator that is integrated into the interface module. To do this, slide the sliding switch to the "on" position or to the upper end position.
4. If the module is not at the beginning or at the end, you must slide the sliding switch to the "off" position or to the lower end position.

▶ Preparing for Operation on the RS-485 Interface

For operation on an RS-485 interface, the terminals on connector X1 must be connected as follows:

1. Connect terminal 4 "Rx 422+" to terminal 6 "Tx 422+."
2. Connect terminal 5 "Rx 422-" to terminal 7 "Tx 422-."

Terminal		Description
4	Rx 422+	RS-485+ data line to WCS reader
5	Rx 422-	RS-485- data line to WCS reader
6	Tx 422+	Connect terminal 6 "Tx 422+" to terminal 4 "Rx 422+"
7	Tx 422-	Connect terminal 7 "Tx 422-" to terminal 5 "Rx 422-"

Table 3.2 Terminal X1

Connecting the WCS Reader

If you connect several WCS readers to one interface module, the WCS readers must have different addresses. This will allow the programmable logic controller to allocate the data to the correct WCS readers. If you only connect one WCS reader to an interface module, this WCS reader always receives the address 0. You can connect up to four WCS readers to an interface module via an RS-485 cable. Each WCS reader is supplied with the default address of 0. Details of how to change the address of the WCS reader can be found in the configuration instructions for the WCS reader.

WCS reader connection pin			Interface module terminal
WCS2A	WCS3A	WCS3B	
2	1	1	X2-1
4	2	2	X1-4
1	3	4	X1-5
3	5	3	X2-2

Connection to the Control Panel

Connect the WCS-CG310 interface module to the CANopen® bus via the 9-pin connector. This requires a 9-pin D-Sub socket that is plugged into the 9-pin D-Sub plug on the device. This socket is not within the scope of delivery for the interface module.

Set the module ID of the CANopen® address via the 6-pin "Node ID" DIP switch. Node ID "0" is not allowed. The highest value bit for the seven-digit module ID is "0."

You can switch the terminator in the CANopen® bus on and off via the "Termination" sliding switch.

Interface Module Connection—CAN Bus

Pin	Description
1	-
2	CAN-L
3	CAN-GND
4	-
5	-
6	-
7	CAN-H
8	-
9	-

Table 3.3 WCS-CG310 terminal, bus side

3.3

Dismounting



Dismounting the modules

Use a suitable slot-head screwdriver for dismounting the module.

1. Disconnect all the supply and signal lines.

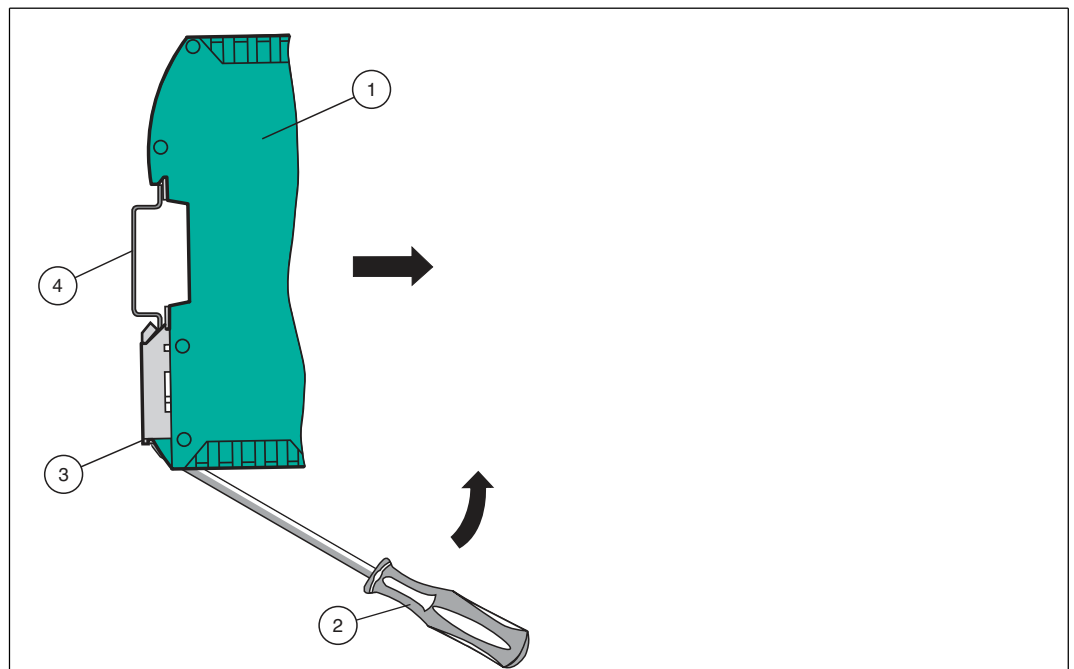

Figure 3.3 Dismounting

2. Insert the screwdriver (2) into the groove of the mounting bracket (3).
3. Press the screwdriver (2) in the specified direction until the lock on the DIN mounting rail (4) opens, see figure.
4. Then press the module (1) upwards and lift it out of the DIN mounting rail.

4 Operation

4.1 Data Exchange in the CANopen® Bus

The WCS-CG310 works as a CANopen® slave in the "Predefined Connection Set." Five objects are defined for the data of the WCS readers:

Object 0x2000:	1 byte—function byte for addressing the WCS readers
Object 0x2001:	4 bytes of data from WCS reader address 0
Object 0x2002:	4 bytes of data from WCS reader address 1
Object 0x2003:	4 bytes of data from WCS reader address 2
Object 0x2004:	4 bytes of data from WCS reader address 3

The data format of the objects 0x2001...0x2004 is identical. The PDO (process data object) can be used to access the objects. The following applies:

PDO1(tx):	Objects 0x2001 and 0x2002 are sent.
PDO2(tx):	Objects 0x2003 and 0x2004 are sent.
PDO1(rx):	Object 0x2000 is received.
PDO2(rx):	Not used

Object 0x2000—Polling

In polling, a function byte is sent from the master to the WCS-CG310. The WCS-CG310 returns 16 data bytes. The 16 bytes contain the data of the four WCS readers (4 x 4 bytes). If fewer than 4 WCS readers are configured (via rotary switch S4), the 4 data bytes for the WCS readers that are not configured contain the value 0x00.

Bit	WCS reader address 3		WCS reader address 2		WCS reader address 1		WCS reader address 0	
	7	6	5	4	3	2	1	0
	0	F0	0	F0	0	F0	0	F0

Table 4.1 Function byte for addressing the WCS reader(s) during polling

Meaning of F0

F0	Function number for WCS reader
0	Send position value
1	Send diagnosis result

Function Number for WCS Reader F0=0 (Send Position Value)

DB	ERR	OUT	Description	Optical state of WCS reader
0	0	0	Current position value binary coded in P00...P18	Good
0	0	1	WCS reader outside of the code rail, no position value	Good
			P0...P18=0: WCS reader partly outside the code rail	
			P0=1, P2...P18=0: WCS reader completely outside of the code rail	
1	0	0	Current position value binary coded in P00...P18	Poor
1	0	1	No position value, WCS reader outside of the code rail	Poor
X	1	X	No position value, error message from WCS reader, error number binary coded in P00...P18	-

2018-09

Function Number for WCS Reader F0=1 (Send Diagnosis Result)

DB	ERR	OUT	Description	Optical state of WCS reader
1	0	0	Diagnosis invalid, WCS reader not outside of the code rail	-
1	0	1	Diagnosis result in P16...P18	
			P16...P18=0	Good
			P16...P18>0	Poor
X	1	X	Error message from WCS reader, error message binary coded in P00...P04	-

The WCS reader can be requested to perform a diagnosis of the photoelectrics by means of the request byte. For this purpose, the WCS reader must be located outside of the code rail.

On the WCS2B and WCS3B readers, the pollution degree of the optical unit is monitored automatically during operation and the diagnostic bit (DB) is set if pollution is too high. Thus the specific request for diagnosis to the WCS reader via F0 in the request byte is no longer necessary. For reasons of backward compatibility, this function is also supported by the new WCS readers.

Diagnostic bit (DB)

The diagnostic bit (DB) indicates the result of the integrated diagnostics of the WCS reader.

Object 0x2001...0x2004—Data Format of the Interface Module for a WCS Reader

Bit	15	14	13	12	11	10	9	8	7	6	5	4	3	2	1	0
Word n	0	0	0	0	0	P18	P17	P16	P15	P14	P13	P12	P11	P10	P09	P08
Word n+1	P07	P06	P05	P04	P03	P02	P01	P00	0	0	0	DB	ERR	OUT	A1	A0

Table 4.2 Data format of the interface module for a reader (4 byte)

Pxx: position data, P00 = LSB

Example: Byte 5 = 00011011 = 27, corresponds to 2.7 m/s

A1, A0: reader address, 00 = WCS reader #1

DB: pollution indicator, 1 = cleaning necessary

OUT: code rail lost, 0 = code rail recognized

ERR: fault indicator, error code (LEDs)

If a WCS reader is not configured, all 4 data bytes of the corresponding object contain the value of 0x00. A WCS reader is not configured if the number of connected WCS readers does not match the number set on the rotary switch S4.

The object 1011 h (restore default parameters) is not supported by WCS-CG310.

Address Bits A1 and A0

A1	A0	Reader address
0	0	Reader address 0
0	1	Reader address 1
1	0	Reader address 2
1	1	Reader address 3

5 Appendix

5.1 Cable Routing in the RS-485 Bus

The data cables must always form an in-line connection between the first and the last node. This in-line connection must end with a terminator.

The RS-485 terminators are integrated in the WCS readers and can be switched on and off with the interface module.

If only **one WCS reader** is connected, one device is connected at the beginning and one device is connected at the end of the data line.

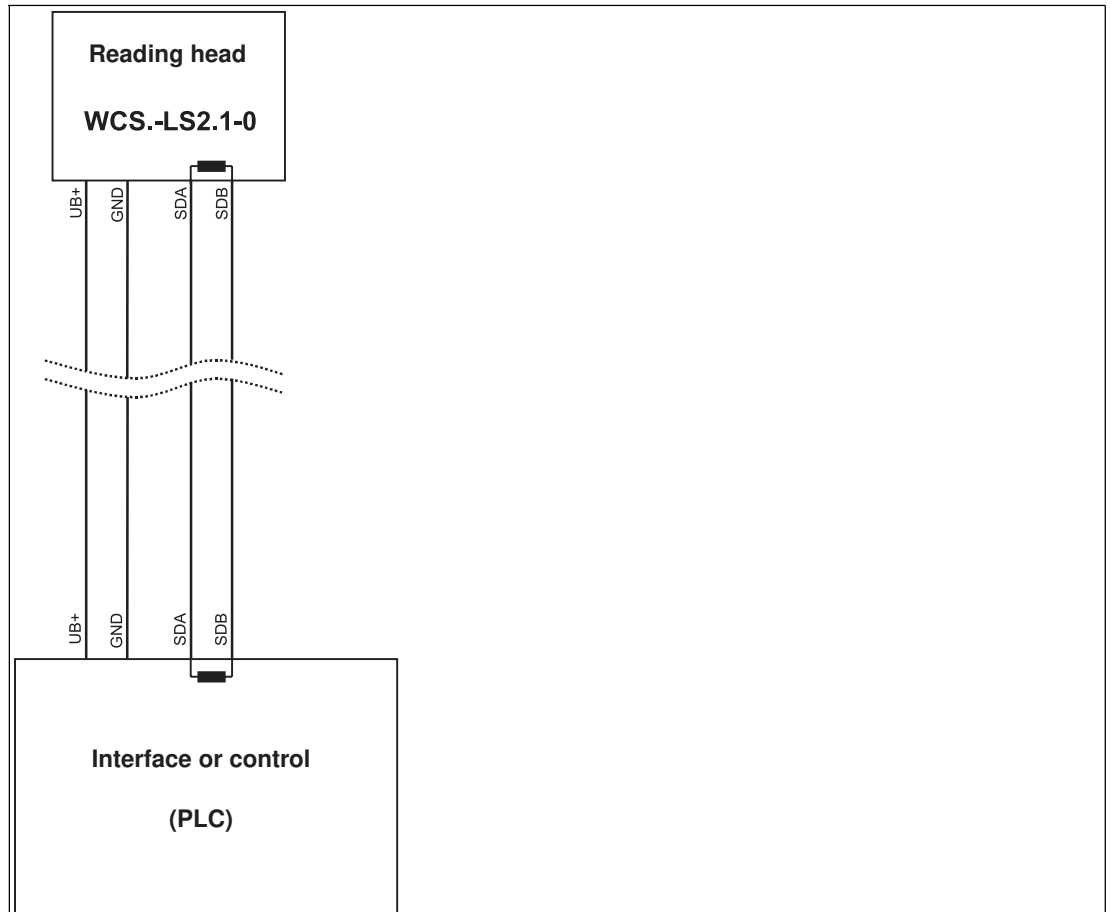

Figure 5.1 Connection of **one** reading head

If **two WCS readers** are connected to one interface module, there are two wiring versions:

■ **Version A:**

One WCS reader is located at the beginning and one WCS reader at the end of the data line. For both WCS readers, the RS-485 terminator is activated. The interface module is located between these two readers and does not have an RS-485 terminator. Each WCS reader is connected to the interface module by a separate data cable.

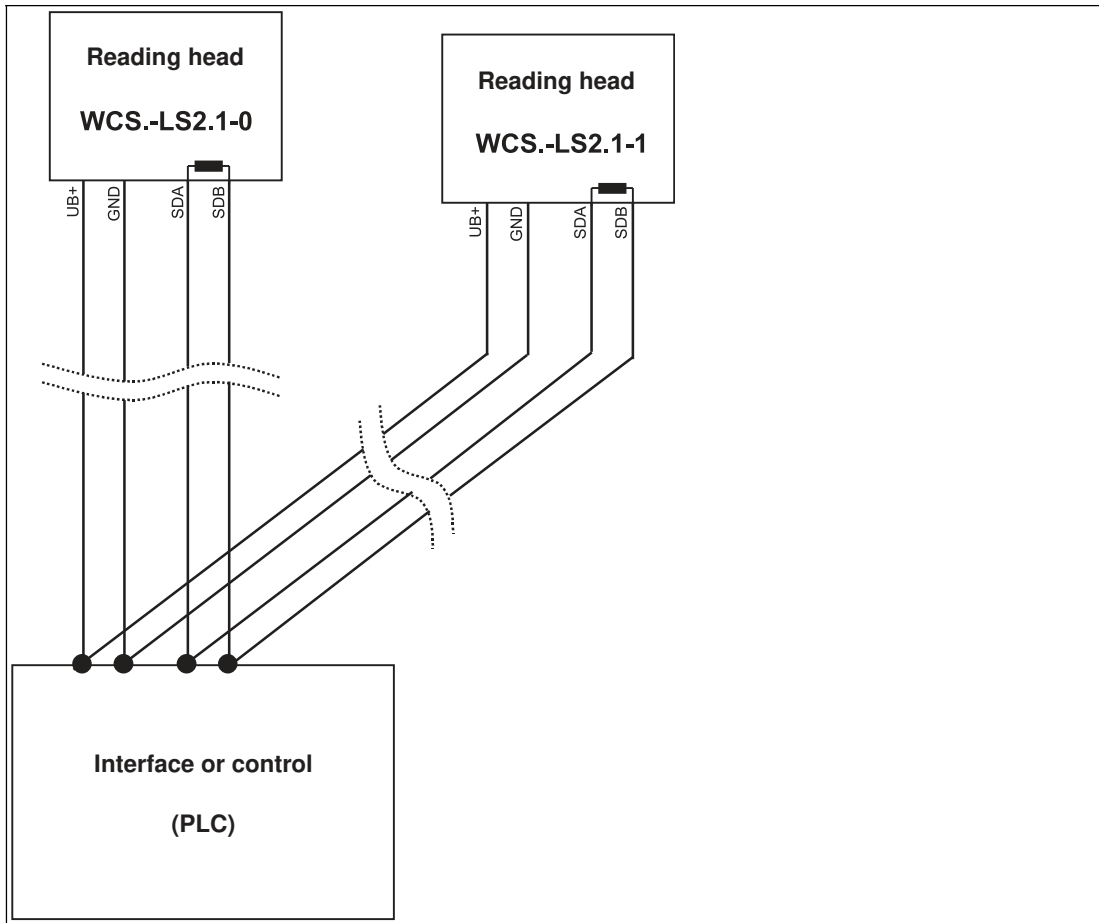

Figure 5.2 Connection of **two** reading heads, Version A

■ **Version B:**

The interface module is located at the beginning of the data line; one WCS reader is located at the end of the data line. Both need the RS-485 terminator. The second WCS reader is connected to the line connection between the interface module and the first WCS reader through a short spur (length <1 m). Use a bus terminal to connect the spur.

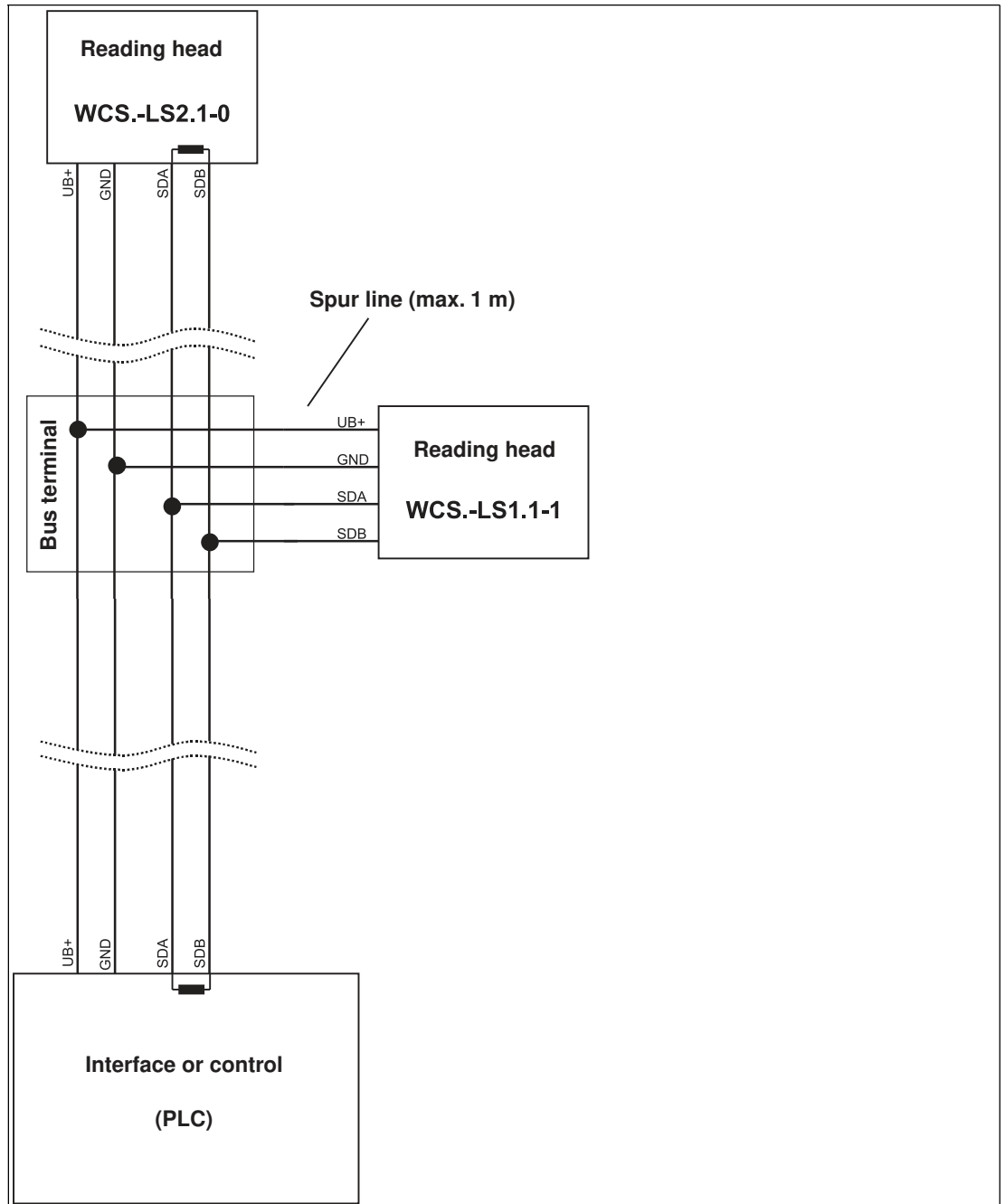

Figure 5.3 Connection of **two** reading heads, Version B

The wiring version used depends on which is best suited for the application. If **three** or **four** **WCS readers** are used on the same interface module, connect these using spurs as shown in variant B.

5.2 Data Cables and Accessories

RS485 data cable

For the RS 485 data transfer path, a 4-wire, shielded, twisted pair data cable must be used. One wire pair is used for the supply voltage, and one pair for the RS 485 data connection. The maximum length of the cable depends on the data transfer capacity of the data cable (core-core) and on the cross section of the cables for power supply of the WCS readers. For data transfer, a small core cross section, and thus small cable capacitance is an advantage, whereas for the power supply the largest possible cross section is required. The table below shows the possible cable lengths depending on the cable cross section.

In the calculations, the worst case scenario was assumed: All WCS readers are located at the end of the data line. In the case of large cable lengths, and when connecting multiple WCS2 readers with heating, 6-wire data cable (3 x 2) can be used. These data cables use 2 pairs for the power supply (doubling the cable cross section), and one pair for the RS 485 data line.

Capacitance (core-core)	RS485 interface		
	19.2 KB (LS246)	62.5 KB (LS221)	187.5 KB (LS211)
60 pF	500 m	500 m	300 m
90 pF	500 m	450 m	275 m
120 pF	500 m	400 m	250 m

The table shows the possible cable lengths depending on the cable capacitance (core-core). The number of connected WCS readers is of no significance.

SSI data cable

For SSI data transfer, a 6-wire, shielded, twisted pair data cable (3 x 2) must be used. One wire pair is used for the supply voltage, one pair for the CLK line, and one pair for the DATA line. The cable lengths that are technically possible can be determined from the T tables.

Capacitance (core-core)	SSI Interface		
	125 kHz	250 kHz	500 kHz
60 pF	200 m	100 m	30 m
90 pF	150 m	80 m	25 m
120 pF	100 m	60 m	20 m

Cable cross section	AWG	Number of WCS readers without heating				Number of WCS readers with heating			
		1	2	3	4	1	2	3	4
0.14 mm ²	~ 26	200 m	110 m	70 m	50 m	15 m	10 m	7 m	5 m
0.22 mm ²	~ 24	320 m	170 m	110 m	80 m	30 m	15 m	10 m	7 m
0.25 mm ²		350 m	190 m	130 m	90 m	35 m	17 m	12 m	8 m
0.28 mm ²		400 m	220 m	150 m	110 m	40 m	20 m	15 m	10 m
0.34 mm ²	~ 22	500 m	250 m	180 m	140 m	50 m	25 m	17 m	12 m
0.50 mm ²	~ 20	500 m	400 m	270 m	200 m	70 m	35 m	25 m	17 m

WCS-DCS / WCS-DCF data cables

There are 2 types of data cable available:

- . WCS-DCS for stationary cable routing
- . WCS-DCF for trailing cable and drag chain installations.

The data cables are twisted pair, and have a tinned copper braided shield. The braided shield surrounds all wire pairs. The parameters of the data cable for RS 485 and SSI data transfer applications are listed in the table below.

	WCS-DCS	WCS-DCF
Capacitance (core-core)	95 pF/m	60 pF/m
Cross section	0.14 mm ²	0.25 mm ²
Number of wires	6 (3 x 2)	6 (3 x 2)
External diameter	5.8 mm	7.5 mm
Temperature range	-30 °C ... 70 °C	-40 °C ... 70 °C
Order designation	WCS-DCS	WCS-DCF

Single-ended female cordsets and adapter cables

Field-attachable female connectors M12 x 1

	Number of poles	Cable diameter	Order designation
straight	4	6 mm – 8 mm	V1-G-PG9
angled	4	6 mm – 8 mm	V1-W-PG9
straight	5	6 mm – 8 mm	V15-G-PG9
angled	5	6 mm – 8 mm	V15-W-PG9
straight	6	6 mm – 8 mm	V17-G-PG9
angled	6	6 mm – 8 mm	V17-W-PG9 *)

Table 5.1 *) Cable outlet on top, not variable

Shielded connection cable with molded single-ended female cordset

	Number of poles	Cable length	Order designation
straight	4	2 m	V1-G-2M-PUR-ABG
straight	4	5 m	V1-G-5M-PUR-ABG
angled	4	2 m	V1-W-2M-PUR-ABG
angled	4	5 m	V1-W-5M-PUR-ABG
straight	5	5 m	V15-G-5M-PU R-ABG
angled	5	5 m	V15-W-5M-PUR-ABG
straight	8	2 m	V19-G-2M-PU R-ABG
straight	8	5 m	V19-G-5M-PU R-ABG

FACTORY AUTOMATION – SENSING YOUR NEEDS



Worldwide Headquarters

Pepperl+Fuchs GmbH
68307 Mannheim · Germany
Tel. +49 621 776-0
E-mail: info@de.pepperl-fuchs.com

USA Headquarters

Pepperl+Fuchs Inc.
Twinsburg, Ohio 44087 · USA
Tel. +1 330 4253555
E-mail: sales@us.pepperl-fuchs.com

Asia Pacific Headquarters

Pepperl+Fuchs Pte Ltd.
Company Registration No. 199003130E
Singapore 139942
Tel. +65 67799091
E-mail: sales@sg.pepperl-fuchs.com

www.pepperl-fuchs.com

 **PEPPERL+FUCHS**
SENSING YOUR NEEDS

Subject to modifications
Copyright PEPPERL+FUCHS • Printed in Germany

/TDOCT5835__ENG
09/2018