

MANUAL

Functional Safety Solenoid Driver KFD2-SLD-Ex1.13100



SIL 3



With regard to the supply of products, the current issue of the following document is applicable: The General Terms of Delivery for Products and Services of the Electrical Industry, published by the Central Association of the Electrical Industry (Zentralverband Elektrotechnik und Elektroindustrie (ZVEI) e.V.) in its most recent version as well as the supplementary clause: "Expanded reservation of proprietorship"

1	Introduction	4
1.1	Content of this Document	4
1.2	Safety Information	5
1.3	Symbols Used	6
2	Product Description	7
2.1	Function	7
2.2	Interfaces	7
2.3	Marking	7
2.4	Standards and Directives for Functional Safety	8
3	Planning	9
3.1	System Structure	9
3.2	Assumptions	10
3.3	Safety Function and Safe State	11
3.4	Characteristic Safety Values	12
3.5	Useful Life Time	13
4	Mounting and Installation	14
4.1	Configuration	14
5	Operation	15
5.1	Proof Test Procedure	15
6	Maintenance and Repair	17
7	List of Abbreviations	18

1 Introduction

1.1 Content of this Document

This document contains information for usage of the device in functional safety-related applications. You need this information to use your product throughout the applicable stages of the product life cycle. These can include the following:

- Product identification
- Delivery, transport, and storage
- Mounting and installation
- Commissioning and operation
- Maintenance and repair
- Troubleshooting
- Dismounting
- Disposal



Note!

This document does not substitute the instruction manual.



Note!

For full information on the product, refer to the instruction manual and further documentation on the Internet at www.pepperl-fuchs.com.

The documentation consists of the following parts:

- Present document
- Instruction manual
- Manual
- Datasheet

Additionally, the following parts may belong to the documentation, if applicable:

- EU-type examination certificate
- EU declaration of conformity
- Attestation of conformity
- Certificates
- Control drawings
- FMEDA report
- Assessment report
- Additional documents

For more information about functional safety products from Pepperl+Fuchs see www.pepperl-fuchs.com/sil.

1.2 Safety Information

Target Group, Personnel

Responsibility for planning, assembly, commissioning, operation, maintenance, and dismantling lies with the plant operator.

Only appropriately trained and qualified personnel may carry out mounting, installation, commissioning, operation, maintenance, and dismantling of the product. The personnel must have read and understood the instruction manual and the further documentation.

Intended Use

The device is only approved for appropriate and intended use. Ignoring these instructions will void any warranty and absolve the manufacturer from any liability.

The device is developed, manufactured and tested according to the relevant safety standards.

Use the device only

- for the application described
- with specified environmental conditions
- with devices that are suitable for this safety application

Improper Use

Protection of the personnel and the plant is not ensured if the device is not used according to its intended use.

1.3 Symbols Used

This document contains symbols for the identification of warning messages and of informative messages.

Warning Messages

You will find warning messages, whenever dangers may arise from your actions. It is mandatory that you observe these warning messages for your personal safety and in order to avoid property damage.

Depending on the risk level, the warning messages are displayed in descending order as follows:



Danger!

This symbol indicates an imminent danger.

Non-observance will result in personal injury or death.



Warning!

This symbol indicates a possible fault or danger.

Non-observance may cause personal injury or serious property damage.



Caution!

This symbol indicates a possible fault.

Non-observance could interrupt the device and any connected systems and plants, or result in their complete failure.

Informative Symbols



Note!

This symbol brings important information to your attention.



Action

This symbol indicates a paragraph with instructions. You are prompted to perform an action or a sequence of actions.

2 Product Description

2.1 Function

This isolated barrier is used for intrinsic safety applications.

It supplies power to solenoids, LEDs and audible alarms located in a hazardous area.

The device has 2 alternating outputs, in order to be able to operate a valve with 2 coils.

If both inputs are energized, then only output I is energized.

The device is immune to the test pulses of various control systems.

The line fault transparency function can display a line fault in the field by a change in impedance at the switching input of the solenoid driver.

A fault is signaled by LEDs acc. to NAMUR NE44 and a separate collective error message output.

2.2 Interfaces

The device has the following interfaces.

- Safety relevant interfaces: input I, input II, output I, and output II
- Non-safety relevant interfaces: collective error message output



Note!

For corresponding connections see datasheet.

2.3 Marking

Pepperl+Fuchs GmbH Lilienthalstraße 200, 68307 Mannheim, Germany
Internet: www.pepperl-fuchs.com

KFD2-SLD-Ex1.13100	Up to SIL 3
--------------------	-------------

2.4 Standards and Directives for Functional Safety

Device specific standards and directives

Functional safety	IEC/EN 61508, part 1 – 7, edition 2010: Functional safety of electrical/electronic/programmable electronic safety-related systems (manufacturer)
-------------------	--------------------------------------------------------------------------------------------------------------------------------------------------------

System-specific standards and directives

Functional safety	IEC/EN 61511, part 1 – 3, edition 2003: Functional safety – Safety instrumented systems for the process industry sector (user)
-------------------	--------------------------------------------------------------------------------------------------------------------------------------

3 Planning

3.1 System Structure

3.1.1 Low Demand Mode of Operation

If there are two control loops, one for the standard operation and another one for the functional safety, then usually the demand rate for the safety loop is assumed to be less than once per year.

The relevant safety parameters to be verified are:

- the PFD_{avg} value (average **P**robability of dangerous **F**ailure on **D**emand) and the T_1 value (proof test interval that has a direct impact on the PFD_{avg} value)
- the SFF value (**S**afe **F**ailure **F**raction)
- the HFT architecture (**H**ardware **F**ault **T**olerance)

3.1.2 High Demand or Continuous Mode of Operation

If there is only one safety loop, which combines the standard operation and safety-related operation, then usually the demand rate for this safety loop is assumed to be higher than once per year.

The relevant safety parameters to be verified are:

- the PFH value (**P**robability of dangerous **F**ailure per **H**our)
- Fault reaction time of the safety system
- the SFF value (**S**afe **F**ailure **F**raction)
- the HFT architecture (**H**ardware **F**ault **T**olerance)

3.1.3 Safe Failure Fraction

The safe failure fraction describes the ratio of all safe failures and dangerous detected failures to the total failure rate.

$$SFF = (\lambda_s + \lambda_{dd}) / (\lambda_s + \lambda_{dd} + \lambda_{du})$$

A safe failure fraction as defined in IEC/EN 61508 is only relevant for elements or (sub)systems in a complete safety loop. The device under consideration is always part of a safety loop but is not regarded as a complete element or subsystem.

For calculating the SIL of a safety loop it is necessary to evaluate the safe failure fraction of elements, subsystems and the complete system, but not of a single device.

Nevertheless the SFF of the device is given in this document for reference.

3.2 Assumptions

The following assumptions have been made during the FMEDA:

- Failure rate based on the Siemens standard SN29500.
- Failure rates are constant, wear is not considered.
- External power supply failure rates are not included.
- The safety-related device is considered to be of type **A** device with a hardware fault tolerance of **0**.
- The device will be used under average industrial ambient conditions, which are comparable with the classification "stationary mounted" in MIL-HDBK-217F. Alternatively, the following ambient conditions are assumed:
 - IEC/EN 60654-1 Class C (sheltered location) with temperature limits in the range of the manufacturer's specifications and an average temperature of 40 °C over a long period. The humidity level is within manufacturer's rating. For a higher average temperature of 60 °C, the failure rates must be multiplied by a factor of 2.5 based on experience. A similar factor must be used if frequent temperature fluctuations are expected.
- The device shall claim less than 10 % of the total failure rate for a SIL 3 safety loop.
- For a SIL 3 application operating in low demand mode the total PFD_{avg} value of the SIF (**S**afety **I**nstrumented **F**unction) should be smaller than 10^{-3} , hence the maximum allowable PFD_{avg} value would then be 10^{-4} .
- For a SIL 3 application operating in high demand mode the total PFH value of the SIF should be smaller than 10^{-7} per hour, hence the maximum allowable PFH value would then be 10^{-8} per hour.
- Since the safety loop has a hardware fault tolerance of **0** and it is a type **A** device, the SFF must be > 90 % according to table 2 of IEC/EN 61508-2 for a SIL 3 (sub) system.

3.3 Safety Function and Safe State

Safe State

The safe state of the output is the de-energized state. In the safe state, the maximum residual power P_{off} is ≤ 10 mW and the maximum residual voltage U_{off} is ≤ 6 V.

Safety Function

When the input signal is active, the output is activated. The safe state is introduced when the input voltage is below 5 V DC.

Reaction Time

The reaction time for all safety functions is < 1 s.



Note!

The collective error message output is not safety relevant.



Note!

The device configuration via DIP switches is not safety relevant.



Note!

See corresponding datasheets for further information.

3.4 Characteristic Safety Values

Parameters acc. to IEC 61508	Characteristic values
Assessment type	Full assessment
Device type	A
Mode of operation	Low demand mode, high demand mode or continuous mode
HFT	0
SIL (SC)	3
Safety function	The output is de-energized if the input is in low condition
λ_s	362 FIT
λ_{dd}	0 FIT
λ_{du}	1.24 FIT
λ_{total} (safety function)	363.24 FIT
SFF ¹	99.6 %
PTC	100 %
MTBF ²	82 years
PFH	1.24×10^{-9} 1/h
PFD _{avg} for $T_1 = 1$ year	5.45×10^{-6}
PFD _{avg} for $T_1 = 2$ years	1.09×10^{-5}
PFD _{avg} for $T_1 = 5$ years	2.72×10^{-5}
PFD _{avg} for $T_1 = 10$ years	5.44×10^{-5}
Reaction time	< 1 s

Table 3.1

¹ "No effect failures" and "Annunciation failures" are not influencing the safety function and are therefore not included in SFF and in the failure rates of the safety function.

² acc. to SN29500. This value includes failures which are not part of the safety function/MTTR = 24 h.



Note!

The characteristic values apply to all modes of operation that can be set on the device.

The characteristic safety values like PFD, PFH, SFF, HFT and T_1 are taken from the FMEDA report. Observe that PFD and T_1 are related to each other.

The function of the devices has to be checked within the proof test interval (T_1).

3.5 Useful Life Time

Although a constant failure rate is assumed by the probabilistic estimation this only applies provided that the useful lifetime of components is not exceeded. Beyond this useful lifetime, the result of the probabilistic estimation is meaningless as the probability of failure significantly increases with time. The useful lifetime is highly dependent on the component itself and its operating conditions – temperature in particular. For example, the electrolytic capacitors can be very sensitive to the operating temperature.

This assumption of a constant failure rate is based on the bathtub curve, which shows the typical behavior for electronic components.

Therefore it is obvious that failure calculation is only valid for components that have this constant domain and that the validity of the calculation is limited to the useful lifetime of each component.

It is assumed that early failures are detected to a huge percentage during the installation and therefore the assumption of a constant failure rate during the useful lifetime is valid.

However, according to IEC/EN 61508-2, a useful lifetime, based on general experience, should be assumed. Experience has shown that the useful lifetime often lies within a range period of about 8 to 12 years.

As noted in DIN EN 61508-2:2011 note N3, appropriate measures taken by the manufacturer and plant operator can extend the useful lifetime.

Our experience has shown that the useful lifetime of a Pepperl+Fuchs product can be higher if the ambient conditions support a long life time, for example if the ambient temperature is significantly below 60 °C.

Please note that the useful lifetime refers to the (constant) failure rate of the device. The effective life time can be higher.

4 Mounting and Installation



Installing the Device

1. Observe the safety instructions in the instruction manual.
2. Observe the information in the manual.
3. Observe the requirements for the safety loop.
4. Connect the device only to devices that are suitable for this safety application.
5. Check the safety function to ensure the expected output behavior.

4.1 Configuration



Note!

The device configuration via DIP switches is not safety relevant.



Configuring the Device

The device is configured via DIP switches. The DIP switches are on the front of the device.

1. De-energize the device before configuring the device.
2. Open the cover.
3. Configure the device via the DIP switches.
4. Close the cover.
5. Secure the DIP switches to prevent unintentional adjustments.
6. Connect the device again.



Note!

See corresponding datasheets for further information.

5 Operation



Danger!

Danger to life from missing safety function

If the safety loop is put out of service, the safety function is no longer guaranteed.

- Do not deactivate the device.
- Do not bypass the safety function.
- Do not repair, modify, or manipulate the device.



Operating the device

1. Observe the safety instruction in the instruction manual.
2. Observe the information in the manual.
3. Use the device only with devices that are suitable for this safety application.
4. Correct any occurring safe failures within 24 hours. Take measures to maintain the safety function while the device is being repaired.

5.1 Proof Test Procedure

According to IEC/EN 61508-2 a recurring proof test shall be undertaken to reveal potential dangerous failures that are not detected otherwise.

Check the function of the subsystem at periodic intervals depending on the applied PFD_{avg} in accordance with the characteristic safety values. See chapter 3.4.

It is under the responsibility of the plant operator to define the type of proof test and the interval time period.

Check the settings after the configuration by suitable tests.

Equipment required:

- Digital multimeter without special accuracy
Use for the proof test of the intrinsic safety side of the device a special digital multimeter for intrinsically safe circuits.
If intrinsically safe circuits are operated with non-intrinsically safe circuits, they must no longer be used as intrinsically safe circuits.
- Power supply set to values according to the table below
- Load resistor with $130\ \Omega$ and 1 W



Proof Test Procedure

1. Prepare a test set-up, see figure below.
2. Test the devices in the mode of operation they are used in. If necessary, change the configuration of the device. For both channels, verify the input and output values as given in table below.
3. Set back the device to the original settings after the test.

Step No.	Supply voltage	Input I value	Input II value	Output I value	Output II value
1	24 V DC	19 V (high)	5 V (low)	On/> 100 mA	Off/< 4 mA
2	24 V DC	5 V (low)	19 V (high)	Off/< 4 mA	On/> 100 mA
3	24 V DC	19 V (high)	19 V (high)	On/> 100 mA	Off/< 4 mA
4	24 V DC	5 V (low)	5 V (low)	Off/< 4 mA	Off/< 4 mA
5	0 V DC	0 V	0 V	Off/0 mA	Off/0 mA

Table 5.1 Steps to be performed for the proof test

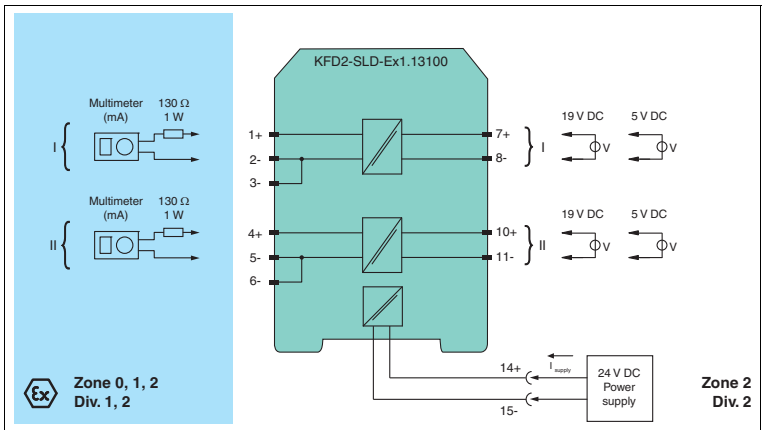

Figure 5.1 Proof test set-up for KFD2-SLD-Ex1.13100

6 Maintenance and Repair



Danger!

Danger to life from missing safety function

If the safety loop is put out of service, the safety function is no longer guaranteed.

- Do not deactivate the device.
- Do not bypass the safety function.
- Do not repair, modify, or manipulate the device.



Maintaining, Repairing or Replacing the Device

In case of maintenance, repair or replacement of the device, proceed as follows:

1. Implement appropriate maintenance procedures for regular maintenance of the safety loop.
2. Ensure the proper function of the safety loop, while the device is maintained, repaired or replaced.
If the safety loop does not work without the device, shut down the application.
Do not restart the application without taking proper precautions.
Secure the application against accidental restart.
3. Do not repair a defective device. A defective device must only be repaired by the manufacturer.
4. Replace a defective device only by a device of the same type.

7 List of Abbreviations

ESD	Emergency Shutdown
FIT	Failure In Time in 10^{-9} 1/h
FMEDA	Failure Mode, Effects, and Diagnostics Analysis
λ_s	Probability of safe failure
λ_{dd}	Probability of dangerous detected failure
λ_{du}	Probability of dangerous undetected failure
$\lambda_{no\ effect}$	Probability of failures of components in the safety loop that have no effect on the safety function. The no effect failure is not used for calculation of SFF.
$\lambda_{not\ part}$	Probability of failure of components that are not in the safety loop
$\lambda_{total\ (safety\ function)}$	Safety function
HFT	Hardware Fault Tolerance
MTBF	Mean Time Between Failures
MTTR	Mean Time To Restoration
PCS	Process Control System
PFD_{avg}	Average Probability of dangerous Failure on Demand
PFH	Average frequency of dangerous failure
PTC	Proof Test Coverage
SFF	Safe Failure Fraction
SIF	Safety Instrumented Function
SIL	Safety Integrity Level
SIL (SC)	Safety Integrity Level (Systematic Capability)
SIS	Safety Instrumented System
T₁	Proof Test Interval



PROCESS AUTOMATION – PROTECTING YOUR PROCESS



Worldwide Headquarters

Pepperl+Fuchs GmbH
68307 Mannheim · Germany
Tel. +49 621 776-0
E-mail: info@de.pepperl-fuchs.com

For the Pepperl+Fuchs representative
closest to you check www.pepperl-fuchs.com/contact

www.pepperl-fuchs.com

Subject to modifications
Copyright PEPPERL+FUCHS • Printed in Germany

 **PEPPERL+FUCHS**
PROTECTING YOUR PROCESS

DOCT-5836
08/2017